

MEC-E8003

Beam, Plate and Shell Models

2023

WEEK 13: PLATES

5 PLATE

5.1 PLATE MODELS	3
5.2 PLATE EQUATIONS	10
5.3 CARTESIAN COORDINATES	18
5.4 CURVILINEAR COORDINATES	24
5.5 VIRTUAL WORK DENSITIES	34
5.6 KIRCHHOFF PLATE EQUATIONS	39
5.7 APPROXIMATE SOLUTIONS	44

LEARNING OUTCOMES

Students are able to solve the weekly lecture problems, home problems, and exercise problems on the plate model:

- Reissner-Mindlin and Kirchhoff plate models.
- Derivation of the plate equations by using the principle of virtual work, integration by parts, and the fundamental lemma of variation calculus. Plate equilibrium and constitutive equations in their tensor forms.
- Component representations of the plate equations in (x, y, z) – and (r, ϕ, n) – coordinate systems.
- Approximate series solutions to plate equations.

5.1 PLATE MODELS

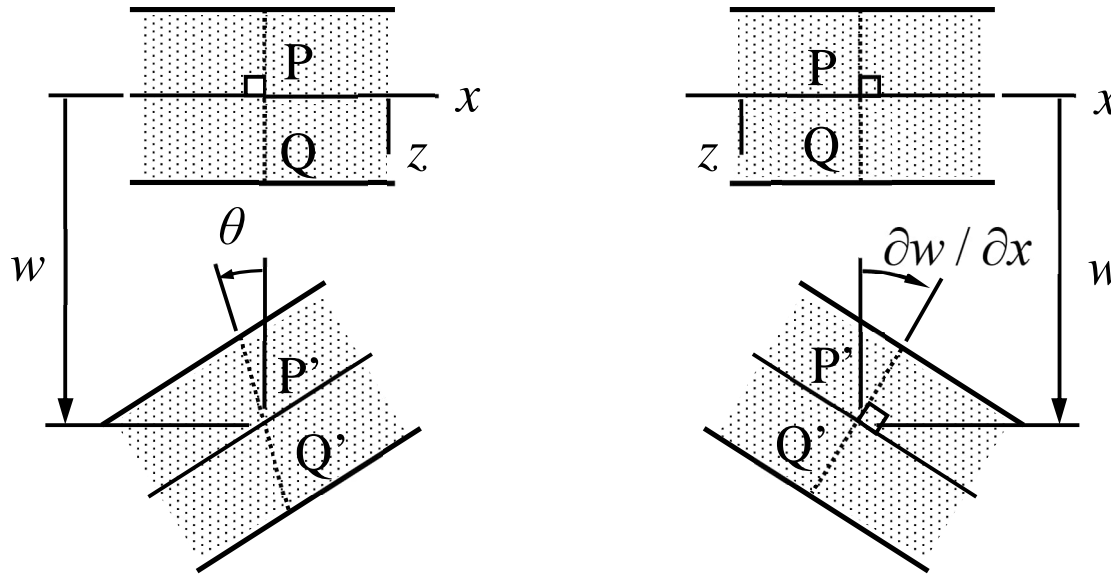

Kinematic assumption: Line segments perpendicular to the mid/reference-plane remain straight in deformation (Reissner-Mindlin) and perpendicular to the mid-plane (Kirchhoff). Then, line segments move as rigid bodies according to $\vec{u} = \vec{u}_0 + \vec{\theta}_0 \times \vec{\rho}$.

Kinetic assumption: Normal stress in the thickness direction is negligible.

The kinematic assumption means that the normal line segments to the mid-plane move as rigid bodies in deformation. In terms of displacement of the translation point $z = 0$ and small rotation of the line segments, displacement of a particle (x, y, z) is given by $\vec{u} = (u\vec{i} + v\vec{j} + w\vec{k}) + (\phi\vec{i} + \theta\vec{j}) \times (z\vec{k})$ in which the translation and rotation components depend on the mid-plane position (x, y) . The kinetic assumption of the plate model is $\sigma_{zz} = 0$.

In the Kirchhoff model, line segments are assumed to remain normal to the mid-plane in deformation which brings the *Kirchhoff constraints* ($\nabla w + \vec{\omega}_0 = 0$, $\vec{\omega}_0 = \vec{\theta}_0 \times \vec{k}$)

$$\gamma_{xz} = \frac{\partial w}{\partial x} + \theta = 0 \quad \text{and} \quad \gamma_{yz} = \frac{\partial w}{\partial y} - \phi = 0.$$

The modeling error in the Kirchhoff plate model is larger than that of the Reissner-Mindlin plate model!

BENDING MODE OF KIRCHHOFF PLATE

Kirchhoff model is the practical choice for the bending of thin isotropic and homogeneous simply supported plates. Assuming that the origin of the transverse axis is placed at the mid-plane, the boundary value problem for bending of a simply supported plate loaded by distributed transverse force b_n is given by

$$\nabla_0^2 \nabla_0^2 w - \frac{b_n}{D} = 0 \quad \text{in } \Omega,$$

$$w = 0 \quad \text{and} \quad D \frac{\partial^2 w}{\partial n^2} = 0 \quad \text{on } \partial\Omega$$

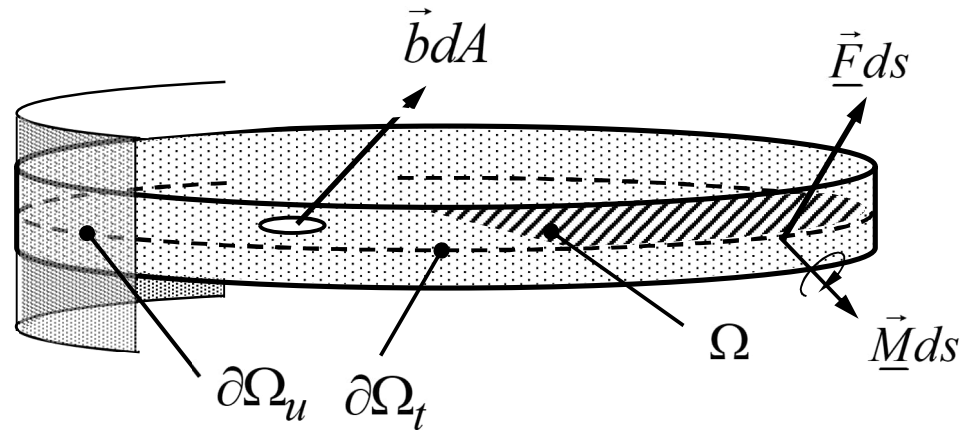

in which $D = \frac{Et^3}{12(1-\nu^2)}$ is the bending stiffness of the plate and $\nabla = \nabla_0 + \vec{e}_n \frac{\partial}{\partial n}$.

EXAMPLE 5.1 Consider bending of a simply supported Kirchhoff plate in the rectangle domain $\Omega = (0, L) \times (0, H)$. Thickness t , Young's modulus E , and Poisson's ratio ν , and distributed load b in direction of z -axis are constants. Derive the double sine series solution of the form $w(x, y) = \sum_{i=1}^{\infty} \sum_{j=1}^{\infty} w_{ij} \sin(i\pi x / L) \sin(j\pi y / H)$.

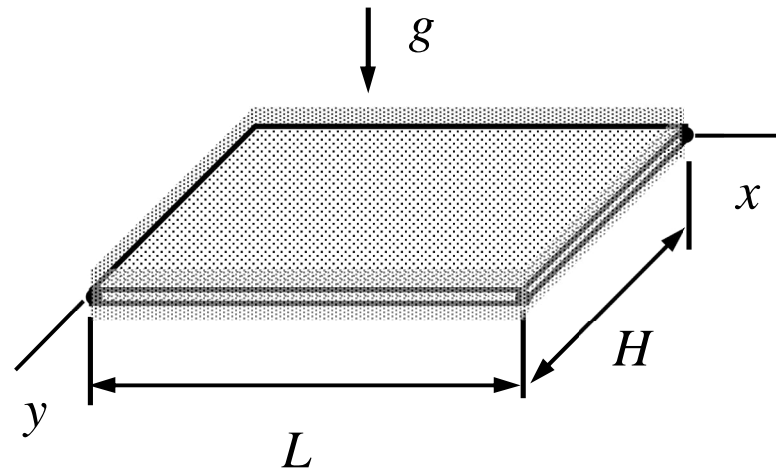

Answer $w_{ij} = 16 \frac{b}{D} \frac{1}{ij\pi^6} \left[\left(\frac{i}{L} \right)^2 + \left(\frac{j}{H} \right)^2 \right]^{-2} \quad i, j \in \{1, 3, 5, \dots\}, \quad w_{ij} = 0 \text{ otherwise.}$

The double sine series satisfies the simply supported boundary conditions 'a priori'. Elimination of the stress resultants gives the fourth order differential equation for the transverse displacement

$$\frac{\partial^4 w}{\partial x^4} + 2\frac{\partial^4 w}{\partial x^2 \partial y^2} + \frac{\partial^4 w}{\partial y^4} = \frac{b}{D}, \text{ where } D = \frac{Et^3}{12(1-\nu^2)}.$$

The series solution is based on the orthogonality properties of the sine and cosine functions (like)

Cronecker del ta 

$$\int_0^L \sin(i\pi \frac{x}{L}) \sin(j\pi \frac{x}{L}) dx = \delta_{ij} \frac{L}{2} \quad \text{and} \quad \int_0^L \sin(i\pi \frac{x}{L}) dx = \frac{L}{i\pi} [1 - (-1)^i]$$

$$\int_0^H \sin(i\pi \frac{y}{H}) \sin(j\pi \frac{y}{H}) dy = \delta_{ij} \frac{H}{2} \quad \text{and} \quad \int_0^H \sin(i\pi \frac{y}{H}) dy = \frac{H}{i\pi} [1 - (-1)^i]$$

When the series approximation is substituted into the equilibrium equation, the outcome is

$$\sum_{i=1}^{\infty} \sum_{j=1}^{\infty} w_{ij} \left[\left(\frac{i\pi}{L} \right)^2 + \left(\frac{j\pi}{H} \right)^2 \right]^2 \sin\left(i\pi \frac{x}{L}\right) \sin\left(j\pi \frac{y}{H}\right) = \frac{b}{D}.$$

The unknown coefficient can be solved by multiplying both sides of the equation by $\sin(k\pi x / L) \sin(l\pi y / H)$, integrating over the domain $\Omega = (0, L) \times (0, H)$, and using orthogonality of sine functions:

$$w_{ij} \frac{L}{2} \frac{H}{2} \left[\left(\frac{i\pi}{L} \right)^2 + \left(\frac{j\pi}{H} \right)^2 \right]^2 = \frac{b}{D} \frac{LH}{ij\pi^2} [1 - (-1)^i] [1 - (-1)^j] \quad \Leftrightarrow$$

$$w_{ij} = 16 \frac{b}{D} \frac{1}{ij\pi^6} \frac{1}{\left[\left(\frac{i}{L} \right)^2 + \left(\frac{j}{H} \right)^2 \right]^2} \quad i, j \in \{1, 3, 5, \dots\}, \quad w_{ij} = 0 \text{ otherwise.} \quad \leftarrow$$

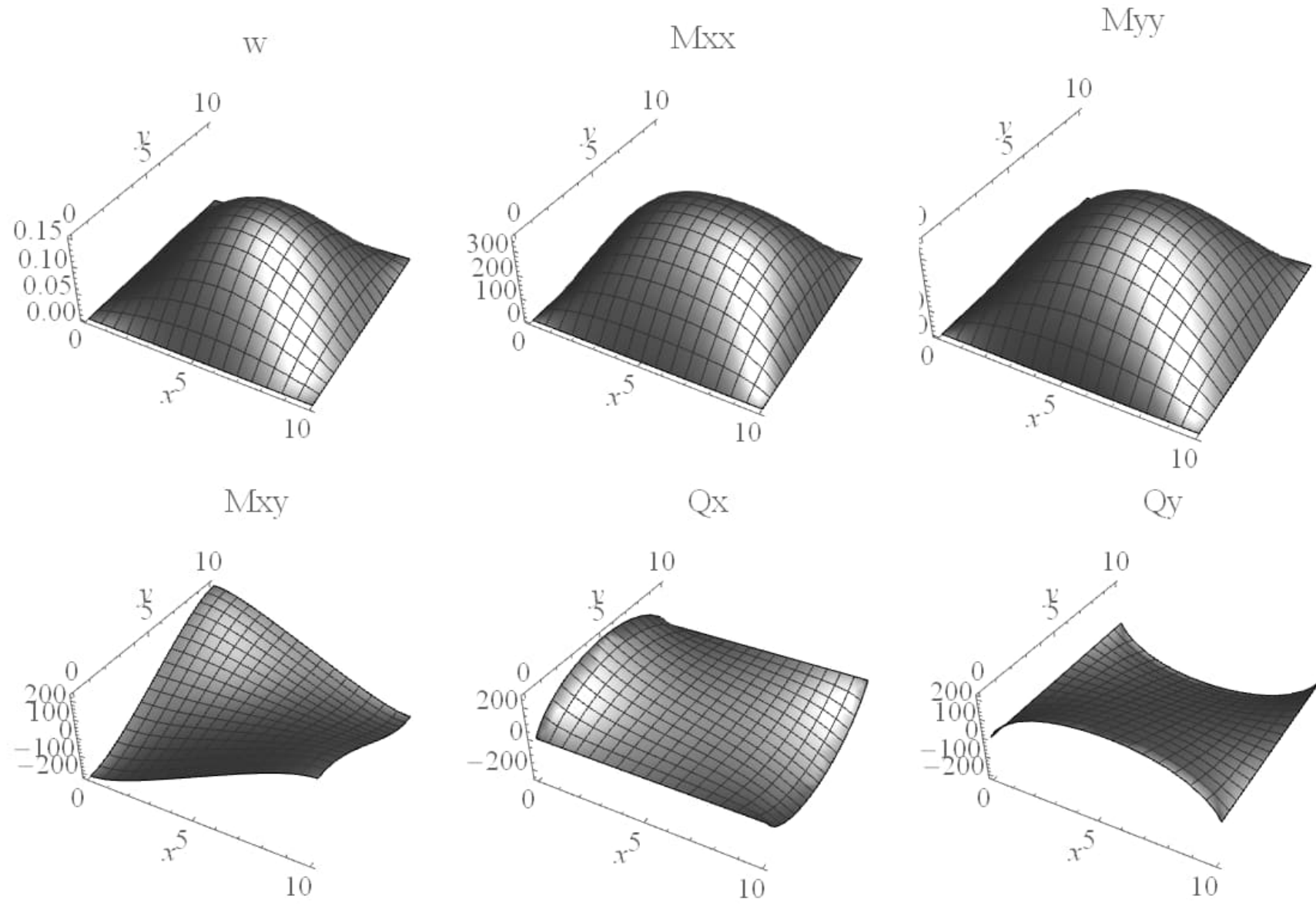

5.2 PLATE EQUATIONS

Virtual work expression of plate, principle of virtual work, integration by parts, and the fundamental lemma of variation calculus give (\vec{e}_n is the normal to the mid-plane):

$$\nabla_0 \cdot \vec{F} + \vec{b} = 0 \quad \text{in } \Omega,$$

$$\nabla_0 \cdot \vec{M} - \vec{e}_n \cdot \vec{F} = 0 \quad \text{in } \Omega,$$

$$\vec{n} \cdot \vec{F} - \underline{\vec{F}} = 0 \quad \text{or} \quad \vec{u}_0 - \underline{\vec{u}}_0 = 0 \quad \text{on } \partial\Omega,$$

$$(\vec{n} \cdot \vec{M} - \underline{\vec{M}}) \times \vec{e}_n = 0 \quad \text{or} \quad \vec{\theta}_0 - \underline{\vec{\theta}}_0 = 0 \quad \text{on } \partial\Omega.$$

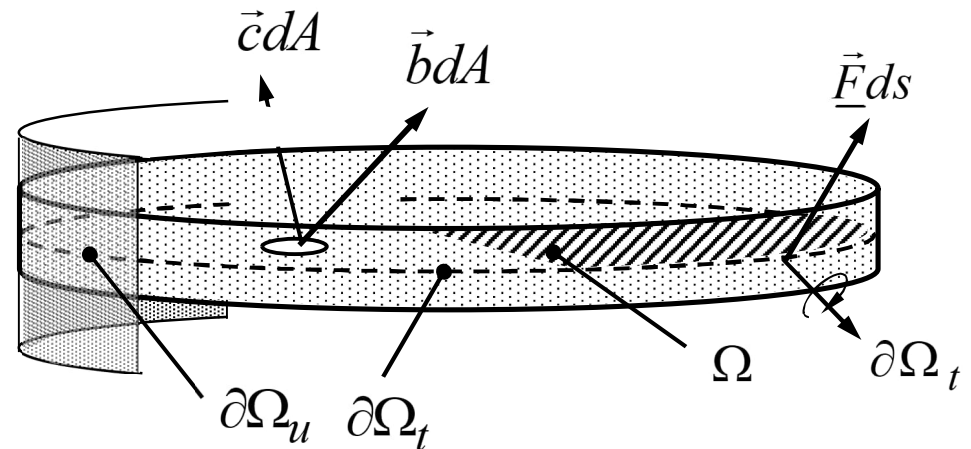

Stress resultants are symmetric so that $\vec{F} = \vec{F}_c$ and $\vec{M} = \vec{M}_c$. Constitutive equations $\vec{M} = \vec{M}(\vec{u}_0, \vec{\theta}_0)$, $\vec{F} = \vec{F}(\vec{u}_0, \vec{\theta}_0)$ are needed for a closed equation system!

In terms of the stress and external force resultants, virtual work densities of the plate model ($\vec{\omega}_0 = \vec{\theta}_0 \times \vec{e}_n \Leftrightarrow \vec{\theta}_0 = \vec{e}_n \times \vec{\omega}_0$) are given by

$$\delta w_{\Omega}^{\text{int}} = - \begin{Bmatrix} \delta \vec{\varepsilon} \\ \delta \vec{\kappa} \end{Bmatrix}_c^T : \begin{Bmatrix} \vec{F} \\ \vec{M} \end{Bmatrix}, \quad \delta w_{\Omega}^{\text{ext}} = - \begin{Bmatrix} \delta \vec{u}_0 \\ \delta \vec{\omega}_0 \end{Bmatrix}^T \cdot \begin{Bmatrix} \vec{b} \\ \vec{c} \end{Bmatrix}, \quad \text{and} \quad \delta w_{\partial\Omega}^{\text{ext}} = - \begin{Bmatrix} \delta \vec{u}_0 \\ \delta \vec{\omega}_0 \end{Bmatrix}^T \cdot \begin{Bmatrix} \vec{F} \\ \vec{M} \end{Bmatrix}$$

where the strain measures of the plate model are $\vec{\varepsilon} = \nabla_0 \vec{u}_0 + \vec{e}_n \vec{\omega}_0$ and $\vec{\kappa} = \nabla_0 \vec{\omega}_0$ and gradient operator $\nabla = \nabla_0 + \vec{e}_n \partial / \partial n$.

Virtual work expression of plate is obtained as integral of the density expression over the plate domain $\Omega \subset \mathbb{R}^2$ (mid-plane)

$$\delta W = - \int_{\Omega} [\vec{F} : (\nabla_0 \delta \vec{u}_0 + \vec{e}_n \delta \vec{\omega}_0)_c + \vec{M} : (\nabla_0 \delta \vec{\omega}_0)_c] dA + \int_{\Omega} (\vec{b} \cdot \delta \vec{u}_0 + \vec{c} \cdot \delta \vec{\omega}_0) dA + \int_{\partial\Omega} (\vec{F} \cdot \delta \vec{u}_0 + \vec{M} \cdot \delta \vec{\omega}_0) ds.$$

Integration by parts gives an equivalent form (the aim is remove the derivatives acting on the variations), retaining the original rotation variable with $\vec{\omega}_0 = \vec{\theta}_0 \times \vec{e}_n$, and using the vector identity $\vec{a} \cdot (\vec{b} \times \vec{c}) = (\vec{a} \times \vec{b}) \cdot \vec{c}$ gives

$$\begin{aligned} \delta W &= \int_{\Omega} [(\nabla_0 \cdot \vec{F} + \vec{b}) \cdot \delta \vec{u}_0 + (\nabla_0 \cdot \vec{M} - \vec{e}_n \cdot \vec{F} + \vec{c}) \cdot \delta \vec{\omega}_0] dA + \\ &\quad \int_{\partial\Omega} [(-\vec{n} \cdot \vec{F} + \vec{F}) \cdot \delta \vec{u}_0 + (-\vec{n} \cdot \vec{M} + \vec{M}) \cdot \delta \vec{\omega}_0] ds \quad \Rightarrow \\ \delta W &= \int_{\Omega} [(\nabla_0 \cdot \vec{F} + \vec{b}) \cdot \delta \vec{u}_0 - [(\nabla_0 \cdot \vec{M} - \vec{e}_n \cdot \vec{F} + \vec{c}) \times \vec{e}_n] \cdot \delta \vec{\theta}_0] dA + \\ &\quad \int_{\partial\Omega} [(-\vec{n} \cdot \vec{F} + \vec{F}) \cdot \delta \vec{u}_0 - [(-\vec{n} \cdot \vec{M} + \vec{M}) \times \vec{e}_n] \cdot \delta \vec{\theta}_0] ds. \end{aligned}$$

Principle of virtual work and the fundamental lemma of variation calculus imply the equilibrium equations and boundary conditions

$$\left. \begin{aligned} \nabla_0 \cdot \vec{F} + \vec{b} &= 0 \quad \text{in } \Omega \\ (\nabla_0 \cdot \vec{M} - \vec{e}_n \cdot \vec{F} + \vec{c}) \times \vec{e}_n &= 0 \quad \text{in } \Omega \end{aligned} \right\} \text{equilibrium eqs.}$$

$$\left. \begin{aligned} \vec{n} \cdot \vec{F} - \underline{\vec{F}} &= 0 \quad \text{or} \quad \vec{u}_0 - \underline{\vec{u}}_0 = 0 \quad \text{on } \partial\Omega \\ (\vec{n} \cdot \vec{M} - \underline{\vec{M}}) \times \vec{e}_n &= 0 \quad \text{or} \quad \vec{\theta}_0 - \underline{\vec{\theta}}_0 = 0 \quad \text{on } \partial\Omega \end{aligned} \right\} \text{boundary conditions}$$

Above, underbars denote given boundary values. Boundary conditions specify either a kinematic quantity or its work conjugate kinetic (force like) quantity.

RESULTANT DEFINITIONS

Stress and external force resultants are integrals over the thickness ($\vec{\omega}_0 = \vec{\theta}_0 \times \vec{e}_n$). Stress resultant definition gives the constitutive equations:

$$\begin{Bmatrix} \vec{F} \\ \vec{M} \end{Bmatrix} = \int \vec{\sigma} \begin{Bmatrix} 1 \\ n \end{Bmatrix} dn = \int \begin{bmatrix} 1 & n \\ n & n^2 \end{bmatrix} \vec{\vec{E}} dn : \begin{Bmatrix} \vec{\varepsilon} \\ \vec{\kappa} \end{Bmatrix} = \begin{bmatrix} \vec{\vec{A}} & \vec{\vec{C}} \\ \vec{\vec{C}} & \vec{\vec{B}} \end{bmatrix} : \begin{Bmatrix} \vec{\varepsilon} \\ \vec{\kappa} \end{Bmatrix},$$

$$\begin{Bmatrix} \vec{b} \\ \vec{c} \end{Bmatrix} = \int \vec{f} \begin{Bmatrix} 1 \\ n \end{Bmatrix} dn, \quad \text{external force and moment per unit area}$$

$$\begin{Bmatrix} \vec{F} \\ \vec{M} \end{Bmatrix} = \int \vec{t} \begin{Bmatrix} 1 \\ n \end{Bmatrix} dn. \quad \text{external force and moment per unit length}$$

Elasticity tensor $\vec{\vec{E}}$ is assumed to satisfy the minor and major symmetries and condition $\vec{e}_n \vec{e}_n : \vec{\vec{E}} = 0$, which implies that the kinetic assumption $\sigma_{nn} = 0$ is satisfied ‘a priori’.

STRESS RESULTANTS

Using the conventional notation for the components in the (x, y, n) coordinate system, assumption $\sigma_{nn} = 0$ and representation $\vec{F} = \vec{N} + \vec{e}_n \vec{Q} + \vec{Q} \vec{e}_n$

$$\vec{N} = \begin{Bmatrix} \vec{i} \\ \vec{j} \end{Bmatrix}^T \begin{bmatrix} N_{xx} & N_{xy} \\ N_{yx} & N_{yy} \end{bmatrix} \begin{Bmatrix} \vec{i} \\ \vec{j} \end{Bmatrix},$$

$$\vec{M} = \begin{Bmatrix} \vec{i} \\ \vec{j} \end{Bmatrix}^T \begin{bmatrix} M_{xx} & M_{xy} \\ M_{yx} & M_{yy} \end{bmatrix} \begin{Bmatrix} \vec{i} \\ \vec{j} \end{Bmatrix}, \text{ and } \vec{Q} = \begin{Bmatrix} \vec{i} \\ \vec{j} \end{Bmatrix}^T \begin{Bmatrix} Q_x \\ Q_y \end{Bmatrix}.$$

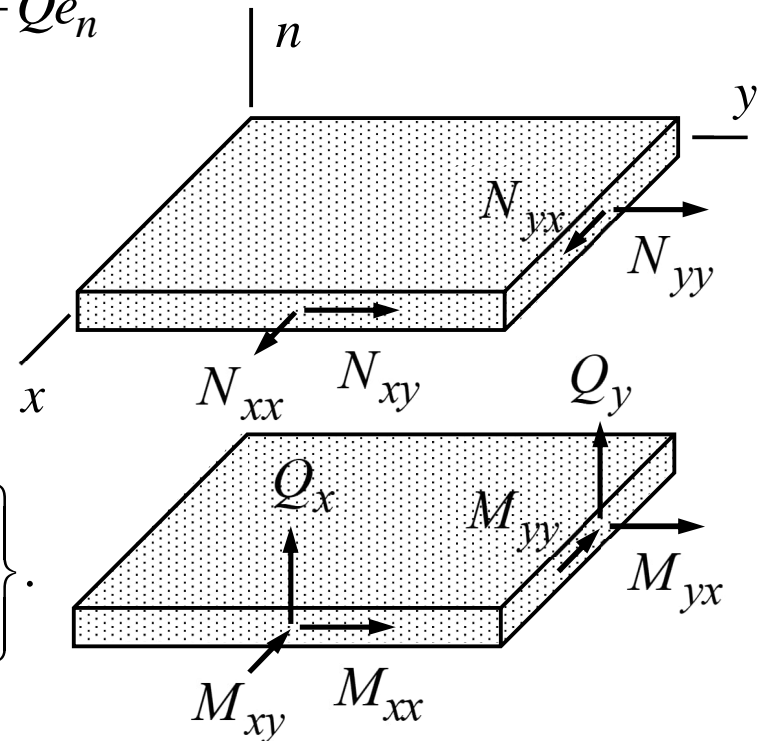

The first and second indices of the components of \vec{M} do not have the same interpretation as those of $\vec{\sigma}$.

BENDING MODE OF KIRCHHOFF PLATE

Equilibrium equations of the Kirchhoff plate model can be deduced from the Reissner-Mindlin equations. However, boundary conditions are somewhat tricky and they require derivation from the virtual work densities:

$$\nabla_0 \cdot \vec{Q} + b_n = 0 \quad \text{and} \quad \vec{Q} = \nabla_0 \cdot \vec{M} \quad \text{in } \Omega,$$

$$M_{nn} - \underline{M}_n = 0 \quad \text{or} \quad \frac{\partial w}{\partial n} + \underline{\theta}_s = 0 \quad \text{on } \partial\Omega,$$

$$Q_n - \underline{Q} + \frac{\partial}{\partial s} (M_{ns} - \underline{M}_s) = 0 \quad \text{or} \quad w - \underline{w} = 0 \quad \text{on } \partial\Omega.$$

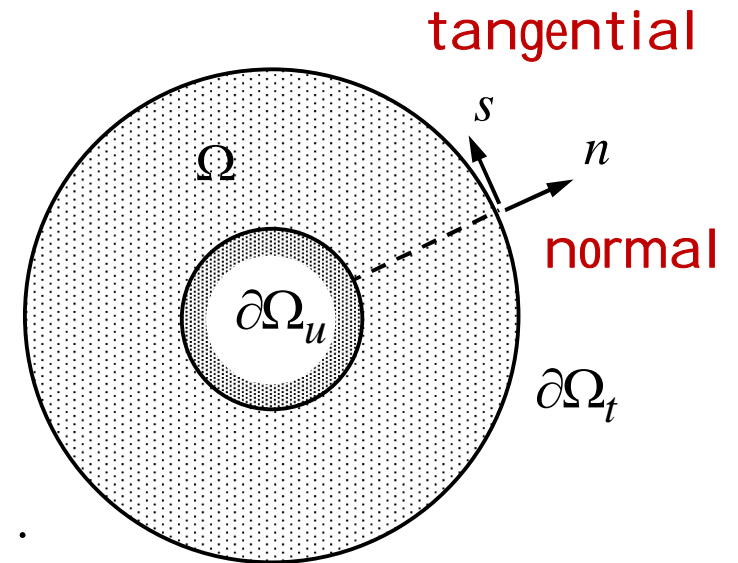

Constitutive equation of the moment resultant $\vec{M} = -\vec{\vec{B}} : \nabla_0 \nabla_0 w$ follow from the Reissner-Mindlin model, Kirchhoff constraint $\vec{\omega}_0 + \nabla_0 w = 0$, and assumes that $\vec{\vec{C}} = 0$.

The equilibrium equation can be deduced from the Reissner-Mindlin equations by separating the thin-slab and bending modes of plate with $\vec{F} = \vec{N} + \vec{e}_n \vec{Q} + \vec{Q} \vec{e}_n$ and $\vec{b} = \vec{b} + \vec{e}_n b_n$ ($\vec{c} = 0$ for simplicity). Then

$$\nabla_0 \cdot \vec{F} + \vec{b} = 0 \quad \text{and} \quad \nabla_0 \cdot \vec{M} - \vec{e}_n \cdot \vec{F} = 0 \quad \Leftrightarrow$$

$$\nabla_0 \cdot \vec{N} + \vec{b}_0 = 0, \quad \nabla_0 \cdot \vec{Q} + b_n = 0, \quad \text{and} \quad \nabla_0 \cdot \vec{M} - \vec{Q} = 0 \quad \Rightarrow$$

$$\nabla_0 \cdot (\nabla_0 \cdot \vec{M}) + b_n = 0. \quad \blackleftarrow$$

The [biharmonic equation](#) for the transverse displacement of literature follows from the constitutive equation of homogeneous and isotropic material

$$\nabla_0 \cdot (\nabla_0 \cdot \vec{M}) + b_n = 0 \quad \text{and} \quad \vec{M} = -\frac{t^2}{12} \vec{\vec{E}} : \nabla_0 \nabla_0 w \quad \Rightarrow \quad D \nabla_0^2 \nabla_0^2 w - b_n = 0. \quad \blackleftarrow$$

5.3 CARTESIAN COORDINATES

Reissner-Mindlin model bending mode equilibrium and constitutive equations in (x, y, n) coordinates follow from the coordinate system invariant forms.

$$\left\{ \begin{array}{l} \frac{\partial Q_x}{\partial x} + \frac{\partial Q_y}{\partial y} + b_n \\ \frac{\partial M_{xx}}{\partial x} + \frac{\partial M_{xy}}{\partial y} - Q_x \\ \frac{\partial M_{yy}}{\partial y} + \frac{\partial M_{xy}}{\partial x} - Q_y \end{array} \right\} = 0, \quad \left\{ \begin{array}{l} M_{xx} \\ M_{yy} \\ M_{xy} \end{array} \right\} = D \begin{bmatrix} 1 & \nu & 0 \\ \nu & 1 & 0 \\ 0 & 0 & \frac{1}{2}(1-\nu) \end{bmatrix} \left\{ \begin{array}{l} \frac{\partial \theta}{\partial x} \\ -\frac{\partial \phi}{\partial y} \\ \frac{\partial \theta}{\partial y} - \frac{\partial \phi}{\partial x} \end{array} \right\}, \quad \text{and}$$

$$\left\{ \begin{array}{l} Q_x \\ Q_y \end{array} \right\} = Gt \left\{ \begin{array}{l} \frac{\partial w}{\partial x} + \theta \\ \frac{\partial w}{\partial y} - \phi \end{array} \right\} \quad \text{in } \Omega. \quad \left(\text{notation } D = \frac{Et^3}{12(1-\nu^2)} \right)$$

EXAMPLE 5.2 Consider the plate strip clamped at its ends and loaded by its own weight. Determine the deflection w and rotation θ of the plate according to the Reissner-Mindlin model. Thickness, width, and length of the plate are t , H , and L , respectively ($H \gg L$). Density ρ , Young's modulus E , and Poisson's ratio ν are constants. Assume that the stress-resultants, displacement, and rotations depend on x only.

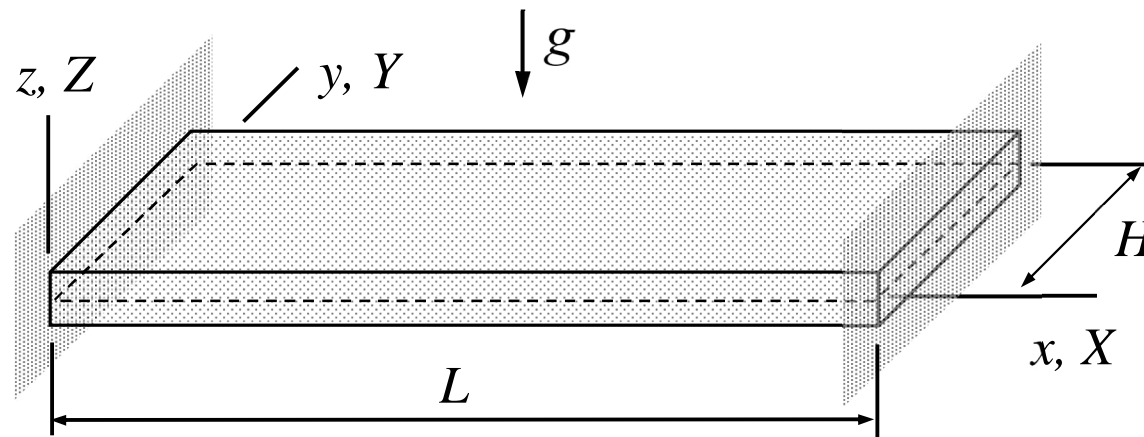

Answer $w(x) = -\rho g(L-x)x\left(\frac{1}{2G} + \frac{t(L-x)x}{24D}\right)$ and $\theta(x) = \frac{\rho g t}{12D}x(L^2 - 3Lx + 2x^2)$

According to the assumption, derivatives with respect to y vanish. The equilibrium and constitutive equations simplify to

$$\frac{dQ_x}{dx} - \rho g t = 0, \quad \frac{dM_{xx}}{dx} - Q_x = 0, \quad M_{xx} = D \frac{d\theta}{dx}, \quad \text{and} \quad Q_x = Gt \left(\frac{dw}{dx} + \theta \right) \quad \text{in} \quad (0, L),$$

Boundary value problem for the transverse displacement and rotation, obtained by eliminating the stress resultants,

$$D \frac{d^2\theta}{dx^2} - Gt \left(\frac{dw}{dx} + \theta \right) = 0, \quad Gt \left(\frac{d^2w}{dx^2} + \frac{d\theta}{dx} \right) - \rho g t = 0 \quad \text{in} \quad (0, L), \quad w = \theta = 0 \quad \text{on} \quad \{0, L\}.$$

gives (use the Mathematica notebook)

$$w(x) = -\rho g (L-x)x \left[\frac{1}{2G} + \frac{t(L-x)x}{24D} \right] \quad \text{and} \quad \theta(x) = \frac{\rho g t}{12D} x(L^2 - 3Lx + 2x^2). \quad \leftarrow$$

KIRCHHOFF PLATE EQUATIONS

Equilibrium and constitutive equations of the bending mode according to the Kirchhoff model follow from the Reissner-Mindlin equations

$$\left\{ \begin{array}{l} \frac{\partial Q_x}{\partial x} + \frac{\partial Q_y}{\partial y} + b_n \\ \frac{\partial M_{xx}}{\partial x} + \frac{\partial M_{xy}}{\partial y} - Q_x \\ \frac{\partial M_{yy}}{\partial y} + \frac{\partial M_{xy}}{\partial x} - Q_y \end{array} \right\} = 0, \quad \left\{ \begin{array}{l} M_{xx} \\ M_{yy} \\ M_{xy} \end{array} \right\} = D \begin{bmatrix} 1 & \nu & 0 \\ \nu & 1 & 0 \\ 0 & 0 & \frac{1}{2}(1-\nu) \end{bmatrix} \left\{ \begin{array}{l} \frac{\partial \theta}{\partial x} \\ -\frac{\partial \phi}{\partial y} \\ \frac{\partial \theta}{\partial y} - \frac{\partial \phi}{\partial x} \end{array} \right\}, \text{ and}$$

$$\left\{ \begin{array}{l} \frac{\partial w}{\partial x} + \theta \\ \frac{\partial w}{\partial y} - \phi \end{array} \right\} = 0 \text{ in } \Omega.$$

**Kirchhoff
constraints!**

EXAMPLE 5.3 Consider the plate strip clamped at its ends and loaded by its own weight. Determine the deflection w and rotation θ of the plate according to the Kirchhoff model. Thickness, width, and length of the plate are t , H , and L , respectively ($H \gg L$). Density ρ , Young's modulus E , and Poisson's ratio ν are constants. Assume that the stress-resultants, displacement, and rotations depend on x only.

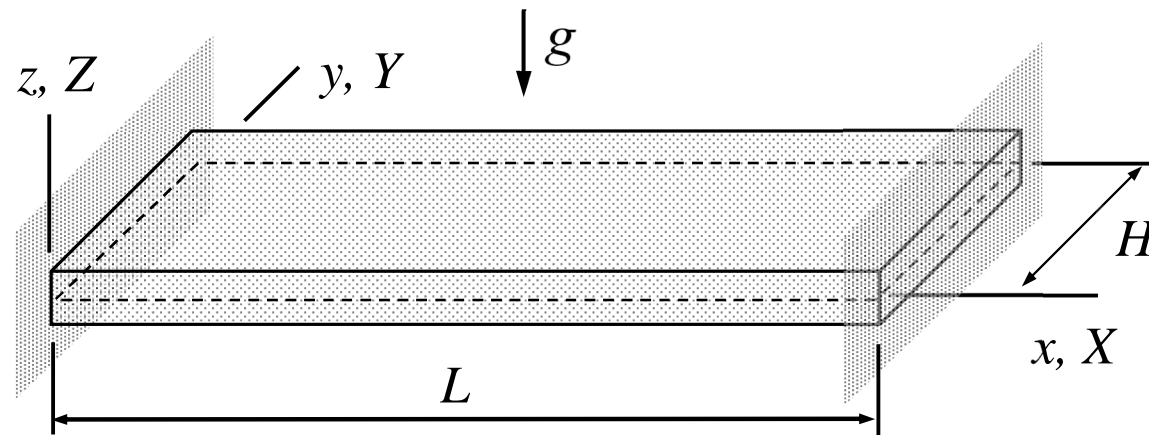

Answer $w(x) = -\frac{\rho g t}{24D} (L-x)^2 x^2$ and $\theta(x) = -\frac{dw}{dx} = \frac{\rho g t}{12D} x(L^2 - 3Lx + 2x^2)$

According to the assumption, derivatives with respect to y vanish, and the set of partial differential equations becomes a set of ordinary differential equations. The relevant differential equations and the boundary conditions are

$$\frac{dQ_x}{dx} - \rho g t = 0, \quad \frac{dM_{xx}}{dx} - Q_x = 0, \quad M_{xx} = D \frac{d\theta}{dx}, \quad \frac{dw}{dx} + \theta = 0 \quad \text{in } (0, L),$$

$$w = \theta = 0 \quad \text{on } \{0, L\}.$$

Solution to w can be obtained, e.g., by eliminating the rotation and the stress resultants

$$D \frac{d^4 w}{dx^4} + \rho g t = 0 \quad \text{in } (0, L) \quad \text{and} \quad w = \frac{dw}{dx} = 0 \quad \text{on } \{0, L\} \quad \Rightarrow$$

$$w(x) = -\frac{\rho g t}{D} \frac{(L-x)^2 x^2}{24}. \quad \leftarrow$$

5.4 CURVILINEAR COORDINATES

Equilibrium and constitutive equations of the bending mode according to the Reissner-Mindlin model in (r, ϕ, n) coordinates follow from the coordinate system invariant forms:

$$\left\{ \begin{array}{l} \frac{1}{r} \left[\frac{\partial(rQ_r)}{\partial r} + \frac{\partial Q_\phi}{\partial \phi} \right] + b_n \\ \frac{1}{r} \left[\frac{\partial(rM_{rr})}{\partial r} + \frac{\partial M_{r\phi}}{\partial \phi} - M_{\phi\phi} \right] - Q_r \\ \frac{1}{r} \left[\frac{\partial(rM_{r\phi})}{\partial r} + \frac{\partial M_{\phi\phi}}{\partial \phi} + M_{r\phi} \right] - Q_\phi \end{array} \right\} = 0, \quad \left\{ \begin{array}{l} M_{rr} \\ M_{\phi\phi} \\ M_{r\phi} \end{array} \right\} = \frac{t^3}{12} [E]_\sigma \left\{ \begin{array}{l} \frac{\partial \theta_\phi}{\partial r} \\ \frac{1}{r} \left(\theta_\phi - \frac{\partial \theta_r}{\partial \phi} \right) \\ \frac{1}{r} \left(\frac{\partial \theta_\phi}{\partial \phi} + \theta_r \right) - \frac{\partial \theta_r}{\partial r} \end{array} \right\}, \quad \text{and}$$

$$\left\{ \begin{array}{l} Q_r \\ Q_\phi \end{array} \right\} = Gt \left\{ \begin{array}{l} \frac{\partial w}{\partial r} + \theta_\phi \\ \frac{1}{r} \frac{\partial w}{\partial \phi} - \theta_r \end{array} \right\} \text{ in } \Omega. \quad \left(\text{notation } [E]_\sigma = \frac{E}{1-\nu^2} \begin{bmatrix} 1 & \nu & 0 \\ \nu & 1 & 0 \\ 0 & 0 & \frac{1}{2}(1-\nu) \end{bmatrix} \right)$$

The component representations of quantities in the (r, ϕ, n) coordinate system are

$$\vec{Q} = \begin{Bmatrix} \vec{e}_r \\ \vec{e}_\phi \end{Bmatrix}^T \begin{Bmatrix} Q_r \\ Q_\phi \end{Bmatrix}, \quad \vec{M} = \begin{Bmatrix} \vec{e}_r \\ \vec{e}_\phi \end{Bmatrix}^T \begin{bmatrix} M_{rr} & M_{r\phi} \\ M_{\phi r} & M_{\phi\phi} \end{bmatrix} \begin{Bmatrix} \vec{e}_r \\ \vec{e}_\phi \end{Bmatrix}, \quad \nabla_0 = \begin{Bmatrix} \vec{e}_r \\ \vec{e}_\phi \end{Bmatrix}^T \begin{Bmatrix} \frac{\partial}{\partial r} \\ \frac{1}{r} \frac{\partial}{\partial \phi} \end{Bmatrix},$$

$$\vec{\vec{E}} = \begin{Bmatrix} \vec{e}_r \vec{e}_r \\ \vec{e}_\phi \vec{e}_\phi \\ \vec{e}_n \vec{e}_n \end{Bmatrix}^T \frac{E}{1-\nu^2} \begin{bmatrix} 1 & \nu & 0 \\ \nu & 1 & 0 \\ 0 & 0 & 0 \end{bmatrix} \begin{Bmatrix} \vec{e}_r \vec{e}_r \\ \vec{e}_\phi \vec{e}_\phi \\ \vec{e}_n \vec{e}_n \end{Bmatrix} + \begin{Bmatrix} \vec{e}_r \vec{e}_\phi + \vec{e}_\phi \vec{e}_r \\ \vec{e}_\phi \vec{e}_n + \vec{e}_n \vec{e}_\phi \\ \vec{e}_n \vec{e}_r + \vec{e}_r \vec{e}_n \end{Bmatrix}^T G \begin{Bmatrix} \vec{e}_r \vec{e}_\phi + \vec{e}_\phi \vec{e}_r \\ \vec{e}_\phi \vec{e}_n + \vec{e}_n \vec{e}_\phi \\ \vec{e}_n \vec{e}_r + \vec{e}_r \vec{e}_n \end{Bmatrix}.$$

Direct calculation (basis vectors are not constants) gives

$$\nabla_0 \cdot \vec{Q} + b_n = \frac{1}{r} \left[\frac{\partial(rQ_r)}{\partial r} + \frac{\partial Q_\phi}{\partial \phi} \right] + b_n = 0, \quad \blackleftarrow$$

$$\nabla_0 \cdot \vec{M} - \vec{Q} = \begin{Bmatrix} \vec{e}_r \\ \vec{e}_\phi \end{Bmatrix}^T \frac{1}{r} \left\{ \begin{array}{l} \frac{\partial(rM_{rr})}{\partial r} + \frac{\partial M_{r\phi}}{\partial \phi} - M_{\phi\phi} - rQ_r \\ \frac{\partial(rM_{r\phi})}{\partial r} + \frac{\partial M_{\phi\phi}}{\partial \phi} + M_{r\phi} - rQ_\phi \end{array} \right\} = 0, \quad \leftarrow$$

$$\vec{M} = \frac{t^3}{12} \vec{\vec{E}} : \vec{\vec{K}} = \begin{Bmatrix} \vec{e}_r \vec{e}_r \\ \vec{e}_\phi \vec{e}_\phi \\ \vec{e}_\phi \vec{e}_r + \vec{e}_r \vec{e}_\phi \end{Bmatrix}^T D \begin{bmatrix} 1 & \nu & 0 \\ \nu & 1 & 0 \\ 0 & 0 & \frac{1}{2}(1-\nu) \end{bmatrix} \left\{ \begin{array}{l} \frac{\partial \theta_\phi}{\partial r} \\ \frac{1}{r}(\theta_\phi - \frac{\partial \theta_r}{\partial \phi}) \\ \frac{1}{r}(\frac{\partial \theta_\phi}{\partial \phi} + \theta_r) - \frac{\partial \theta_r}{\partial r} \end{array} \right\}, \quad \leftarrow$$

$$\vec{Q} = t \vec{e}_n \cdot \vec{\vec{E}} : \vec{\vec{\varepsilon}} = \begin{Bmatrix} \vec{e}_\phi \\ \vec{e}_r \end{Bmatrix}^T Gt \left\{ \begin{array}{l} \frac{1}{r} \frac{\partial w}{\partial \phi} - \theta_r \\ \frac{\partial w}{\partial r} + \theta_\phi \end{array} \right\}. \quad \leftarrow$$

KIRCHHOFF PLATE EQUATIONS

Equilibrium and constitutive equations of the bending mode according to the Kirchhoff model follow from the Reissner-Mindlin equations

$$\left\{ \begin{array}{l} \frac{1}{r} \left[\frac{\partial(rQ_r)}{\partial r} + \frac{\partial Q_\phi}{\partial \phi} \right] + b_n \\ \frac{1}{r} \left[\frac{\partial(rM_{rr})}{\partial r} + \frac{\partial M_{r\phi}}{\partial \phi} - M_{\phi\phi} \right] - Q_r \\ \frac{1}{r} \left[\frac{\partial(rM_{r\phi})}{\partial r} + \frac{\partial M_{\phi\phi}}{\partial \phi} + M_{r\phi} \right] - Q_\phi \end{array} \right\} = 0, \quad \left\{ \begin{array}{l} M_{rr} \\ M_{\phi\phi} \\ M_{r\phi} \end{array} \right\} = \frac{t^3}{12} [E]_\sigma \left\{ \begin{array}{l} \frac{\partial \theta_\phi}{\partial r} \\ \frac{1}{r} \left(\theta_\phi - \frac{\partial \theta_r}{\partial \phi} \right) \\ \frac{1}{r} \left(\frac{\partial \theta_\phi}{\partial \phi} + \theta_r \right) - \frac{\partial \theta_r}{\partial r} \end{array} \right\}, \text{ and}$$

$$\left\{ \begin{array}{l} \frac{\partial w}{\partial r} + \theta_\phi \\ \frac{1}{r} \frac{\partial w}{\partial \phi} - \theta_r \end{array} \right\} = 0. \quad \text{Kirchhoff constraints!}$$

The various forms in literature follow after elimination of rotations or stress resultants in the generic forms. For example, solving for the shear forces in terms of the moment resultants and eliminating the rotations in the constitutive equations by using the Kirchhoff constraints gives first

$$\begin{Bmatrix} Q_r \\ Q_\phi \end{Bmatrix} = \frac{1}{r} \begin{Bmatrix} \frac{\partial}{\partial r}(rM_{rr}) + \frac{\partial}{\partial \phi} M_{r\phi} - M_{\phi\phi} \\ \frac{\partial}{\partial r}(rM_{r\phi}) + \frac{\partial}{\partial \phi} M_{\phi\phi} + M_{r\phi} \end{Bmatrix}, \quad \begin{Bmatrix} M_{rr} \\ M_{\phi\phi} \\ M_{r\phi} \end{Bmatrix} = -D \begin{Bmatrix} \frac{\partial^2 w}{\partial r^2} + \nu \frac{1}{r} \left(\frac{\partial w}{\partial r} + \frac{1}{r} \frac{\partial^2 w}{\partial \phi^2} \right) \\ \nu \frac{\partial^2 w}{\partial r^2} + \frac{1}{r} \left(\frac{\partial w}{\partial r} + \frac{1}{r} \frac{\partial^2 w}{\partial \phi^2} \right) \\ (1-\nu) \frac{\partial}{\partial r} \left(\frac{1}{r} \frac{\partial w}{\partial \phi} \right) \end{Bmatrix} \Rightarrow$$

$$\nabla_0^2 \nabla_0^2 w = \left[\frac{1}{r} \frac{\partial}{\partial r} \left(r \frac{\partial}{\partial r} \right) + \frac{1}{r^2} \frac{\partial^2}{\partial \phi^2} \right] \left[\frac{1}{r} \frac{\partial}{\partial r} \left(r \frac{\partial}{\partial r} \right) + \frac{1}{r^2} \frac{\partial^2}{\partial \phi^2} \right] w = \frac{b_n}{D}.$$

**Biharmonic
equation**

EXAMPLE 5.4 A simply supported circular plate of radius R is loaded by its own weight as shown in the figure. Write down the boundary value problem giving as its solution the transverse displacement. Use Kirchhoff plate equations in the polar coordinate system. Problem parameters E , ν , ρ and t are constants. Assume that w depends on the radial coordinate only.

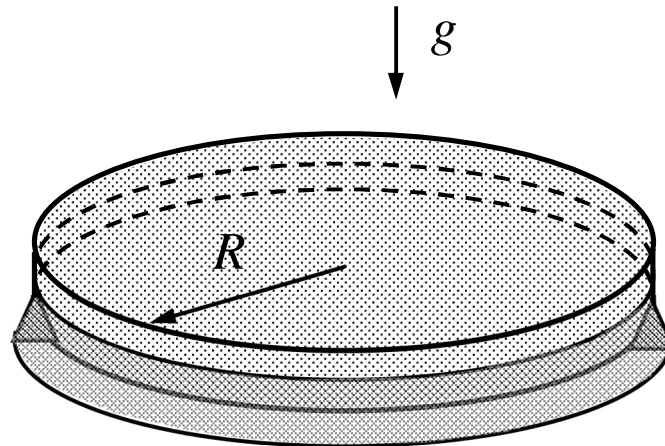

Answer:

$$\left[\frac{1}{r} \frac{d}{dr} \left(r \frac{d}{dr}\right)\right] \left[\frac{1}{r} \frac{d}{dr} \left(r \frac{d}{dr}\right)\right] w - \frac{b_n}{D} = 0 \text{ in } (0, R), \quad M_{rr}(R) = w(R) = -M_{rr}(0) = -Q_r(0) = 0$$

Assuming rotation symmetry, the bending mode equilibrium equation and the boundary conditions of circular simply supported plate of isotropic homogeneous material simplify to

$$\left[\frac{1}{r} \frac{d}{dr} \left(r \frac{d}{dr}\right)\right] \left[\frac{1}{r} \frac{d}{dr} \left(r \frac{d}{dr}\right)\right] w - \frac{b_n}{D} = 0 \quad \text{in } (0, R),$$

$$M_{rr} = -D \left(\frac{d^2 w}{dr^2} + \nu \frac{1}{r} \frac{dw}{dr} \right) = 0 \quad \text{and } w = 0 \quad \text{on } \{R\},$$

$$Q_r = -D \left(\frac{d^3 w}{dr^3} + \frac{1}{r} \frac{d^2 w}{dr^2} - \frac{1}{r^2} \frac{dw}{dr} \right) = 0, \quad M_{rr} = -D \left(\frac{d^2 w}{dr^2} + \nu \frac{1}{r} \frac{dw}{dr} \right) = 0 \quad \text{on } \{0\}.$$

The generic solution to the equilibrium equation in terms of integration constants a , b , c , and d (obtained by repeated integrations) is $w = a + br^2 + cr^2(1 - \log r) + d \log r$.

EXAMPLE 5.5 A simply supported circular plate of radius R is loaded by a point force P acting at the midpoint as shown in the figure. Determine the displacement of the plate at the midpoint by using the Kirchhoff plate model in the polar coordinate system. Problem parameters E , ν and t are constants. Assume that the solution depends on the radial coordinate only. Use the generic solution $w(r) = a + br^2 + cr^2(1 - \log r) + d \log r$.

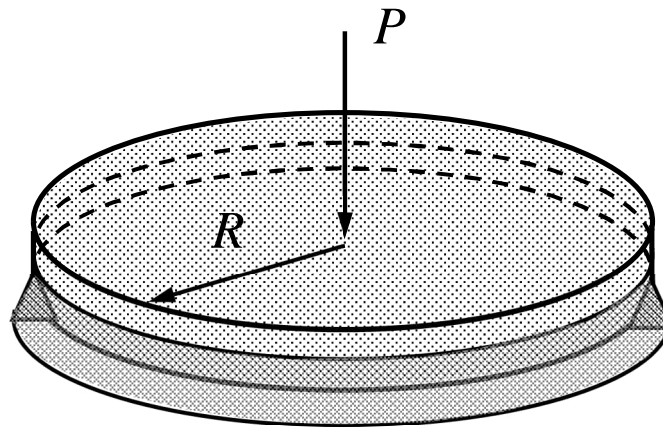

Answer:
$$w(0) = -\frac{1}{16\pi} \frac{PR^2}{D} \frac{3+\nu}{1+\nu} = -\frac{3}{4\pi} \frac{PR^2}{Et^3} (3+\nu)(1-\nu)$$

Let us consider first solution on an annular domain of outer radius R which is simply supported on the outer boundary and loaded by constant distributed force $\underline{Q} = -P / (2\pi\varepsilon)$ on the inner boundary $r = \varepsilon$. Assuming rotation symmetry, the bending mode equilibrium equation and the boundary conditions simplify to

$$\left(\frac{1}{r} \frac{d}{dr} r \frac{d}{dr}\right) \left(\frac{1}{r} \frac{d}{dr} r \frac{d}{dr}\right) w = 0 \quad \text{in } (\varepsilon, R),$$

$$M_{rr}(R) = 0, \quad w(R) = 0 \quad \text{and} \quad -Q_r(\varepsilon) - \underline{Q} = 0, \quad -M_{rr}(\varepsilon) = 0$$

where $Q_r = -D \left(\frac{d^3 w}{dr^3} + \frac{1}{r} \frac{d^2 w}{dr^2} - \frac{1}{r^2} \frac{dw}{dr} \right)$ and $M_{rr} = -D \left(\frac{d^2 w}{dr^2} + \nu \frac{1}{r} \frac{dw}{dr} \right)$.

The generic solution to the biharmonic equation (obtained by repeated integrations) contains parameters a , b , c , and d to be determined from the boundary conditions. When the solution to the linear equations

$$-Q_r(\varepsilon) - \underline{Q} = \frac{1}{2\pi\varepsilon}(P - 8cD\pi) = 0,$$

$$-M_{rr}(\varepsilon) = -\frac{D}{\varepsilon^2}[d - d\nu + \varepsilon^2(c - c\nu - 2b - 2b\nu) + 2c\varepsilon^2(1 + \nu)\log \varepsilon] = 0,$$

$$M_{rr}(R) = \frac{D}{R^2}[d - d\nu + R^2(c - c\nu - 2b - 2b\nu) + 2cR^2(1 + \nu)\log R] = 0,$$

$$w(R) = a + (b + c)R^2 + (d - cR^2)\log R = 0$$

is substituted in the generic solution to the transverse displacement $w(\varepsilon)$, solution to the original problem is obtained as the limit

$$w(0) = \lim_{\varepsilon \rightarrow 0} w(\varepsilon) = -\frac{1}{16\pi} \frac{PR^2}{D} \frac{3 + \nu}{1 + \nu}. \quad \leftarrow$$

4.5 VIRTUAL WORK DENSITIES

Virtual work expressions contain generalized forces (force and moment) corresponding to the chosen kinematic quantities:

$$\delta w_{\Omega}^{\text{int}} = - \begin{Bmatrix} \delta \vec{\varepsilon}_c \\ \delta \vec{\kappa}_c \end{Bmatrix}^T \cdot \begin{Bmatrix} \vec{F} \\ \vec{M} \end{Bmatrix},$$

$$\delta w_{\Omega}^{\text{ext}} = \begin{Bmatrix} \delta \vec{u}_0 \\ \delta \vec{\omega}_0 \end{Bmatrix}^T \cdot \begin{Bmatrix} \vec{b} \\ \vec{c} \end{Bmatrix}, \quad \delta w_{\partial\Omega}^{\text{ext}} = \begin{Bmatrix} \delta \vec{u}_0 \\ \delta \vec{\omega}_0 \end{Bmatrix}^T \cdot \begin{Bmatrix} \vec{F} \\ \vec{M} \end{Bmatrix}$$

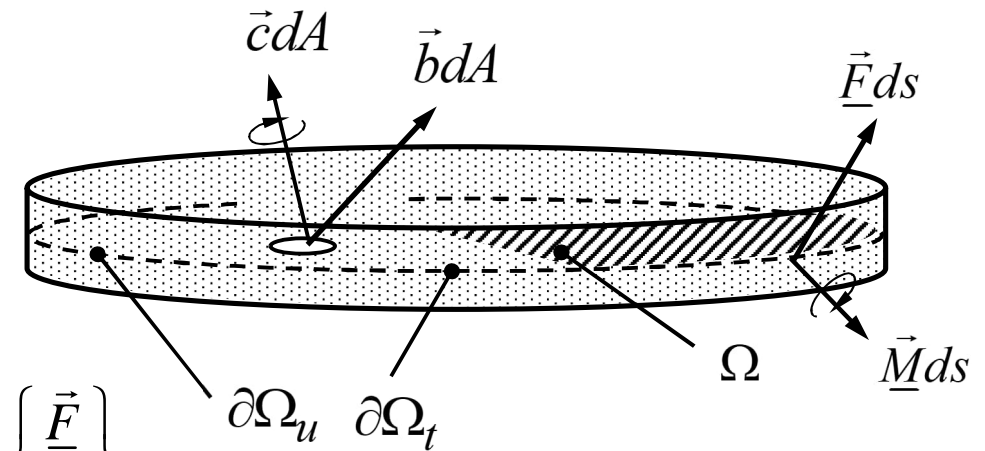

in which

$$\begin{Bmatrix} \vec{F} \\ \vec{M} \end{Bmatrix} = \int \vec{\sigma} \begin{Bmatrix} 1 \\ n \end{Bmatrix} dn, \quad \begin{Bmatrix} \vec{b} \\ \vec{c} \end{Bmatrix} = \int \vec{f} \begin{Bmatrix} 1 \\ n \end{Bmatrix} dn, \quad \begin{Bmatrix} \vec{F} \\ \vec{M} \end{Bmatrix} = \int \vec{t} \begin{Bmatrix} 1 \\ n \end{Bmatrix} dn, \quad \text{and} \quad \vec{\omega}_0 = \vec{\theta}_0 \times \vec{e}_n.$$

Straight line segments perpendicular to the mid/reference-plane remain straight in deformation. In vector notation

$$\vec{u} = \vec{u}_0 + \vec{\theta}_0 \times n\vec{e}_n = \vec{u}_0 + n\vec{\omega}_0 \quad \text{where} \quad \vec{\omega}_0 = \vec{\theta}_0 \times \vec{e}_n \quad \Rightarrow$$

$$\nabla \vec{u} = (\nabla_0 + \vec{e}_n \frac{\partial}{\partial n}) \vec{u} = \nabla_0 \vec{u}_0 + \vec{e}_n \vec{\omega}_0 + n \nabla_0 \vec{\omega}_0 = \vec{\varepsilon} + n\vec{k}$$

where the strain measures of plate $\vec{\varepsilon} = \nabla_0 \vec{u}_0 + \vec{e}_n \vec{\omega}_0$ and $\vec{k} = \nabla_0 \vec{\omega}_0$.

Assuming symmetry of stress $\delta w_V^{\text{int}} = -\vec{\sigma} : (\nabla \delta \vec{u})_c$. Virtual work density of the plate model is obtained by integrating the virtual work density over the small dimension ($dV = dndA$)

$$\delta W_V^{\text{int}} = -\int_{\Omega} \left[\begin{Bmatrix} \delta \vec{\varepsilon} \\ \delta \vec{k} \end{Bmatrix}_c^T : \left(\int \vec{\sigma} \begin{Bmatrix} 1 \\ n \end{Bmatrix} dn \right) \right] dA = -\int_{\Omega} \begin{Bmatrix} \delta \vec{\varepsilon} \\ \delta \vec{k} \end{Bmatrix}_c^T : \begin{Bmatrix} \vec{F} \\ \vec{M} \end{Bmatrix} dA, \quad \text{hence}$$

$$\delta W_{\Omega}^{\text{int}} = - \begin{Bmatrix} \delta \vec{\varepsilon} \\ \delta \vec{\kappa} \end{Bmatrix}_c^T : \begin{Bmatrix} \vec{F} \\ \vec{M} \end{Bmatrix} \quad \text{and} \quad \begin{Bmatrix} \vec{F} \\ \vec{M} \end{Bmatrix} = \int \vec{\sigma} \begin{Bmatrix} 1 \\ n \end{Bmatrix} dn. \quad \leftarrow$$

Virtual work expression of external forces takes into account volume forces and surface forces acting on the body ($dV = dn dA$ and $dA = dn ds$).

$$\delta W_V^{\text{ext}} = \int_V \vec{f} \cdot \delta \vec{u} dV = \int_{\Omega} \left[\begin{Bmatrix} \delta \vec{u}_0 \\ \delta \vec{\omega}_0 \end{Bmatrix}^T \cdot \left(\int \vec{f} \begin{Bmatrix} 1 \\ n \end{Bmatrix} dn \right) \right] dA = \int_{\Omega} \left(\begin{Bmatrix} \delta \vec{u}_0 \\ \delta \vec{\omega}_0 \end{Bmatrix}^T \cdot \begin{Bmatrix} \vec{b} \\ \vec{c} \end{Bmatrix} \right) dA \Rightarrow$$

$$\delta W_{\Omega}^{\text{ext}} = \begin{Bmatrix} \delta \vec{u}_0 \\ \delta \vec{\omega}_0 \end{Bmatrix}^T \cdot \begin{Bmatrix} \vec{b} \\ \vec{c} \end{Bmatrix}, \quad \text{where} \quad \begin{Bmatrix} \vec{b} \\ \vec{c} \end{Bmatrix} = \int \vec{f} \begin{Bmatrix} 1 \\ n \end{Bmatrix} dn. \quad \leftarrow$$

$$\delta W_A^{\text{ext}} = \int_A \vec{t} \cdot \delta \vec{u} dA = \int_{\partial\Omega} \begin{Bmatrix} \delta \vec{u}_0 \\ \delta \vec{\omega}_0 \end{Bmatrix}^T \cdot \left(\int \vec{t} \begin{Bmatrix} 1 \\ n \end{Bmatrix} dn \right) ds \Rightarrow$$

$$\delta w_{\partial\Omega}^{\text{ext}} = \begin{Bmatrix} \delta \vec{u}_0 \\ \delta \vec{\omega}_0 \end{Bmatrix}^T \cdot \begin{Bmatrix} \vec{F} \\ \vec{M} \end{Bmatrix}, \text{ where } \begin{Bmatrix} \vec{F} \\ \vec{M} \end{Bmatrix} = \int \vec{t} \begin{Bmatrix} 1 \\ n \end{Bmatrix} dn. \quad \leftarrow$$

In the derivation, surface forces acting on the top and bottom surfaces of the plate have been omitted for simplicity (they may contribute to \vec{b} and \vec{c}).

RESULTANT DEFINITIONS

Stress and external force resultants are integrals over the thickness ($\vec{\omega}_0 = \vec{\theta}_0 \times \vec{e}_n$). Stress resultant definition gives the constitutive equations:

$$\begin{Bmatrix} \vec{F} \\ \vec{M} \end{Bmatrix} = \int \vec{\sigma} \begin{Bmatrix} 1 \\ n \end{Bmatrix} dn = \int \begin{bmatrix} 1 & n \\ n & n^2 \end{bmatrix} \vec{\vec{E}} dn : \begin{Bmatrix} \vec{\varepsilon} \\ \vec{\kappa} \end{Bmatrix} = \begin{bmatrix} \vec{\vec{A}} & \vec{\vec{C}} \\ \vec{\vec{C}} & \vec{\vec{B}} \end{bmatrix} : \begin{Bmatrix} \vec{\varepsilon} \\ \vec{\kappa} \end{Bmatrix},$$

$$\begin{Bmatrix} \vec{b} \\ \vec{c} \end{Bmatrix} = \int \vec{f} \begin{Bmatrix} 1 \\ n \end{Bmatrix} dn, \quad \text{external force and moment per unit area}$$

$$\begin{Bmatrix} \vec{F} \\ \vec{M} \end{Bmatrix} = \int \vec{t} \begin{Bmatrix} 1 \\ n \end{Bmatrix} dn. \quad \text{external force and moment per unit length}$$

Elasticity dyad $\vec{\vec{E}}$ is assumed to satisfy the minor and major symmetries and condition $\vec{e}_n \vec{e}_n : \vec{\vec{E}} = 0$, which implies that the kinetic assumption $\sigma_{nn} = 0$ is satisfied ‘a priori’.

4.6 KIRCHHOFF PLATE EQUATIONS

Kirchhoff plate model equilibrium and constitutive equations can be deduced from the Reissner-Mindlin ones. However, the somewhat tricky boundary conditions require a more careful consideration starting from the virtual work expression:

$$\nabla_0 \cdot \nabla_0 \cdot \vec{M} + b_n = 0 \quad \text{in } \Omega$$

$$M_{nn} - \underline{M}_n = 0 \quad \text{or} \quad \frac{\partial w}{\partial n} + \underline{\theta}_s = 0 \quad \text{on } \partial\Omega$$

$$Q_n - \underline{Q} + \frac{\partial}{\partial s} (M_{ns} - \underline{M}_s) = 0 \quad \text{or} \quad w - \underline{w} = 0 \quad \text{on } \partial\Omega .$$

In the model, shear stress resultant is a constraint force to be solved from the moment equilibrium equation $\vec{Q} = \nabla_0 \cdot \vec{M}$ and constitutive equation for the moment resultant.

In the Kirchhoff model, straight line segments normal to the mid/reference-plane remain line segments and perpendicular to the mid-plane so that $\nabla_0 w + \vec{\omega}_0 = 0$ (Kirchhoff constraint). After elimination of the rotation components and second integration by parts, the Reissner-Mindlin virtual work expression takes the form

$$\begin{aligned} \delta W &= \int_{\Omega} [(\nabla_0 \cdot \vec{F} + \vec{b}) \cdot \delta \vec{u} - (\nabla_0 \cdot \vec{M} - \vec{e}_n \cdot \vec{F}) \cdot \nabla_0 \delta w] dA + \\ &\quad \int_{\partial\Omega} [(-\vec{n} \cdot \vec{F} + \vec{F}) \cdot \delta \vec{u} - (-\vec{n} \cdot \vec{M} + \vec{M}) \cdot \nabla_0 \delta w] ds \quad \Leftrightarrow \\ \delta W &= \int_{\Omega} [(\nabla_0 \cdot \vec{F} + \vec{b}) \cdot \delta \vec{u} + \nabla_0 \cdot (\nabla_0 \cdot \vec{M} - \vec{e}_n \cdot \vec{F}) \delta w] dA + \\ &\quad \int_{\partial\Omega} [(-\vec{n} \cdot \vec{F} + \vec{F}) \cdot \delta \vec{u} - (-\vec{n} \cdot \vec{M} + \vec{M}) \cdot \nabla_0 \delta w - \vec{n} \cdot (\nabla_0 \cdot \vec{M} - \vec{e}_n \cdot \vec{F}) \delta w] ds. \end{aligned}$$

The thin-slab and bending modes can be separated by writing $\delta \vec{u}_0 = \delta \vec{v}_0 + \delta w \vec{e}_n$. Omitting the thin slab mode ($\vec{Q} = \nabla_0 \cdot \vec{M}$)

$$\delta W = \int_{\Omega} (\nabla_0 \cdot \nabla_0 \cdot \vec{M} + b_n) \delta w dA + \int_{\partial\Omega} (-\vec{n} \cdot \vec{Q} + \underline{Q}) \delta w ds - \int_{\partial\Omega} (-\vec{n} \cdot \vec{M} + \underline{M}) \cdot (\nabla_0 \delta w) ds.$$

As only w and its normal derivative $\partial w / \partial n$ can be varied independently on $\partial\Omega$, some additional manipulations are needed before application of the fundamental lemma of variation calculus. Using division

$$\nabla_0 w = \vec{n} \frac{\partial w}{\partial n} + \vec{s} \frac{\partial w}{\partial s},$$

where \vec{n} and $\vec{s} = \vec{e}_n \times \vec{n}$ are the unit outward normal and tangential vectors to the boundary, integration by parts in the boundary term containing $\partial w / \partial s$ with respect to s gives

$$\delta W = \int_{\Omega} (\nabla_0 \cdot \nabla_0 \cdot \vec{M} + b_n) \delta w dA - \sum_{\Pi} \llbracket -M_{ns} + \underline{M}_s \rrbracket \delta w +$$

$$\int_{\partial\Omega} [-Q_n + \underline{Q} + \frac{\partial}{\partial s}(-M_{ns} + \underline{M}_s)]\delta w ds - \int_{\partial\Omega} (-M_{nn} + \underline{M}_n)\delta \frac{\partial w}{\partial n} ds.$$

Integration by parts is over a closed one-dimensional domain starting and ending at the same point having opposite unit outward normal (± 1). In the expression, $[[\]]$ denotes jump and Π is the set of points where the jump takes place (the usual integration by parts assumes continuity. A more generic form for piecewise continuity contains jump terms). The last term vanishes if the quantity inside the jump brackets is continuous or $\delta w = 0$ on $\partial\Omega$. In what follows we assume so to avoid further discussions about conditions at corners etc. when deflection w is not specified. Arranging the terms gives

$$\delta W = \int_{\Omega} (\nabla_0 \cdot \nabla_0 \cdot \vec{M} + b_n)\delta w d\Omega +$$

$$\int_{\partial\Omega} [-Q_n + \underline{Q} + \frac{\partial}{\partial s}(-M_{ns} + \underline{M}_s)]\delta w ds - \int_{\partial\Omega} (-M_{nn} + \underline{M}_n)\delta \frac{\partial w}{\partial n} ds.$$

Principle of virtual work and the fundamental lemma of variation calculus give

$$\nabla_0 \cdot \nabla_0 \cdot \vec{M} + b_n = 0 \quad \text{in } \Omega ,$$

$$M_{nn} - \underline{M}_n = 0 \quad \text{or} \quad \frac{\partial w}{\partial n} + \underline{\theta}_s = 0 \quad \text{on } \partial\Omega ,$$

$$Q_n - \underline{Q} + \frac{\partial}{\partial s} (M_{ns} - \underline{M}_s) = 0 \quad \text{or} \quad w - \underline{w} = 0 \quad \text{on } \partial\Omega .$$

5.7 APPROXIMATE SOLUTIONS

Principle of virtual work can be used to find approximate series solutions to plate equations. An approximation satisfying the essential boundary conditions ‘a priori’ is just substituted into the virtual work expression by considering the coefficient of the terms of the series as the unknowns. For the plate model

$$\delta W^{\text{int}} = - \int_{\Omega} \delta \left\{ \begin{array}{c} \nabla_0 \vec{u}_0 + \vec{e}_n \vec{\omega}_0 \\ \nabla_0 \vec{\omega}_0 \end{array} \right\}^T \cdot \left[\begin{array}{cc} \vec{\vec{A}} & \vec{\vec{C}} \\ \vec{\vec{C}} & \vec{\vec{B}} \end{array} \right] \cdot \left\{ \begin{array}{c} \nabla_0 \vec{u}_0 + \vec{e}_n \vec{\omega}_0 \\ \nabla_0 \vec{\omega}_0 \end{array} \right\} dA,$$

$$\delta W^{\text{ext}} = \int_{\Omega} \left\{ \begin{array}{c} \delta \vec{u}_0 \\ \delta \vec{\omega}_0 \end{array} \right\}^T \cdot \left\{ \begin{array}{c} \vec{b} \\ \vec{c} \end{array} \right\} dA + \int_{\partial\Omega} \left\{ \begin{array}{c} \delta \vec{u}_0 \\ \delta \vec{\omega}_0 \end{array} \right\}^T \cdot \left\{ \begin{array}{c} \vec{F} \\ \vec{M} \end{array} \right\} ds.$$

Various series solution in literature and the finite element method are just particular cases of this theme.

Assuming that $\vec{\vec{C}} = 0$, the thin slab and bending modes of the plate model disconnect and one may often consider the modes separately. Virtual work expression for the bending mode (Kirchhoff plate model) simplifies to

$$\delta W = -\int_{\Omega} \nabla_0 \nabla_0 w : \vec{\vec{B}} : \nabla_0 \nabla_0 w dA + \int_{\Omega} \delta w b dA.$$

When written in the Cartesian (x, y, n) coordinate system

$$\delta W = -\int_{\Omega} \begin{Bmatrix} \frac{\partial^2 \delta w}{\partial x^2} \\ \frac{\partial^2 \delta w}{\partial y^2} \\ 2 \frac{\partial^2 \delta w}{\partial x \partial y} \end{Bmatrix}^T D \begin{bmatrix} 1 & \nu & 0 \\ \nu & 1 & 0 \\ 0 & 0 & \frac{1}{2}(1-\nu) \end{bmatrix} \begin{Bmatrix} \frac{\partial^2 w}{\partial x^2} \\ \frac{\partial^2 w}{\partial y^2} \\ 2 \frac{\partial^2 w}{\partial x \partial y} \end{Bmatrix} dA + \int_{\Omega} \delta w b_n dA.$$

EXAMPLE 5.6 Consider pure bending of a rectangle Kirchhoff plate $\Omega = (0, L) \times (0, H)$. Derive the series solution $w(x, y) = \sum_{i=1}^{\infty} \sum_{j=1}^{\infty} w_{ij} \sin(i\pi \frac{x}{L}) \sin(j\pi \frac{y}{H})$ by considering the coefficients w_{ij} as the unknowns of the virtual work expression. Thickness t , Young's modulus E , and Poisson's ratio ν , and distributed load b in direction of z -axis are constants.

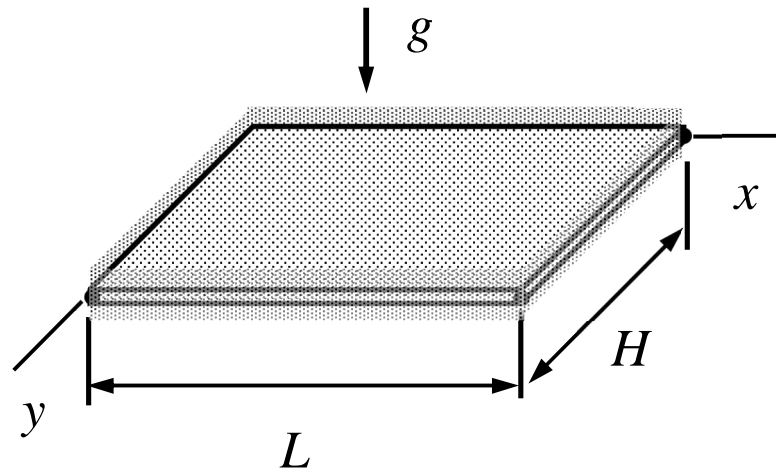

Answer $w_{ij} = 16 \frac{b}{D} \frac{1}{ij} / [(\frac{\pi i}{L})^2 + (\frac{\pi j}{H})^2]^2$ $i, j \in \{1, 3, 5, \dots\}$, $w_{ij} = 0$ otherwise.

When the series approximation is substituted there, the virtual work expression becomes a variational expression for the unknown coefficients. Using then orthogonality of the sines and cosines on $\Omega = (0, L) \times (0, H)$, virtual work expressions of the internal and external forces boil down to

$$\delta W^{\text{int}} = - \sum_{i=1}^{\infty} \sum_{j=1}^{\infty} \delta w_{ij} D \frac{LH}{4} \left[\left(\frac{i\pi}{L} \right)^2 + \left(\frac{j\pi}{H} \right)^2 \right]^2 w_{ij},$$

$$\delta W^{\text{ext}} = - \sum_{i=1}^{\infty} \sum_{j=1}^{\infty} \delta w_{ij} b_{ij}, \text{ where } b_{ij} = \int_0^L \int_0^H b(x, y) \sin(i\pi \frac{x}{L}) \sin(j\pi \frac{y}{H}) dx dy.$$

The fundamental lemma of variation calculus implies that (here $b(x, y) = b = \rho g t$)

$$w_{ij} = b_{ij} / \left[D \frac{LH}{4} \left[\left(\frac{i\pi}{L} \right)^2 + \left(\frac{j\pi}{H} \right)^2 \right]^2 \right], \text{ where } b_{ij} = 4b \frac{LH}{ij\pi^2} \quad i, j \in \{1, 3, 5, \dots\}. \quad \leftarrow$$