

**RAKENNUSTEN LÄMPÖTEKNISET OMINAISUUDET. LÄMMITYKSEN JA JÄÄHDYTYKSEN ENERGIANTARPEEN LASKENTA (ISO 13790:2008)***Energy performance of buildings. Calculation of energy use for space heating and cooling (ISO 13790:2008)*

Tämä standardi sisältää eurooppalaisen standardin EN ISO 13790:2008 "Energy performance of buildings. Calculation of energy use for space heating and cooling (ISO 13790:2008)" englanninkielisen tekstin.

This standard consists of the English text of the European Standard EN ISO 13790:2008 "Energy performance of buildings. Calculation of energy use for space heating and cooling (ISO 13790:2008)".

Eurooppalainen standardi EN ISO 13790:2008 on vahvistettu suomalaiseksi kansalliseksi standardiksi.

The European Standard EN ISO 13790:2008 has the status of a Finnish national standard.



English Version

Energy performance of buildings - Calculation of energy use for
space heating and cooling (ISO 13790:2008)

Performance énergétique des bâtiments - Calcul des
besoins d'énergie pour le chauffage et le refroidissement
des locaux (ISO 13790:2008)

Energieeffizienz von Gebäuden - Berechnung des
Energiebedarfs für Heizung und Kühlung (ISO 13790:2008)

This European Standard was approved by CEN on 23 February 2008.

CEN members are bound to comply with the CEN/CENELEC Internal Regulations which stipulate the conditions for giving this European Standard the status of a national standard without any alteration. Up-to-date lists and bibliographical references concerning such national standards may be obtained on application to the CEN Management Centre or to any CEN member.

This European Standard exists in three official versions (English, French, German). A version in any other language made by translation under the responsibility of a CEN member into its own language and notified to the CEN Management Centre has the same status as the official versions.

CEN members are the national standards bodies of Austria, Belgium, Bulgaria, Cyprus, Czech Republic, Denmark, Estonia, Finland, France, Germany, Greece, Hungary, Iceland, Ireland, Italy, Latvia, Lithuania, Luxembourg, Malta, Netherlands, Norway, Poland, Portugal, Romania, Slovakia, Slovenia, Spain, Sweden, Switzerland and United Kingdom.



EUROPEAN COMMITTEE FOR STANDARDIZATION
COMITÉ EUROPÉEN DE NORMALISATION
EUROPÄISCHES KOMITEE FÜR NORMUNG

Management Centre: rue de Stassart, 36 B-1050 Brussels

Contents

Page

Foreword.....	3
---------------	---

Foreword

This document (EN ISO 13790:2008) has been prepared by Technical Committee ISO/TC 163 "Thermal performance and energy use in the built environment" in collaboration with Technical Committee CEN/TC 89 "Thermal performance of buildings and building components" the secretariat of which is held by SIS.

This European Standard shall be given the status of a national standard, either by publication of an identical text or by endorsement, at the latest by September 2008, and conflicting national standards shall be withdrawn at the latest by September 2008.

Attention is drawn to the possibility that some of the elements of this document may be the subject of patent rights. CEN [and/or CENELEC] shall not be held responsible for identifying any or all such patent rights.

This document supersedes EN ISO 13790:2004, EN 832:1998.

This document has been prepared under a mandate given to CEN by the European Commission and the European Free Trade Association (Mandate M/343), and supports essential requirements of EU Directive 2002/91/EC on the energy performance of buildings (EPBD). It forms part of a series of standards aimed at European harmonisation of the methodology for the calculation of the energy performance of buildings. An overview of the whole set of standards is given in CEN/TR 15615.

Attention is drawn to the need for observance of EU Directives transposed into national legal requirements. Existing national regulations (with or without reference to national standards) may restrict for the time being the implementation of this European Standard.

According to the CEN/CENELEC Internal Regulations, the national standards organizations of the following countries are bound to implement this European Standard: Austria, Belgium, Bulgaria, Cyprus, Czech Republic, Denmark, Estonia, Finland, France, Germany, Greece, Hungary, Iceland, Ireland, Italy, Latvia, Lithuania, Luxembourg, Malta, Netherlands, Norway, Poland, Portugal, Romania, Slovakia, Slovenia, Spain, Sweden, Switzerland and the United Kingdom.

Endorsement notice

The text of ISO 13790:2008 has been approved by CEN as a EN ISO 13790:2008 without any modification.

SFS

INTERNATIONAL STANDARD

ISO 13790

Second edition
2008-03-01

Energy performance of buildings — Calculation of energy use for space heating and cooling

*Performance énergétique des bâtiments — Calcul des besoins
d'énergie pour le chauffage et le refroidissement des locaux*

Tämä julkaisu on ladattu SFS Online-palvelusta (sop. nro) 07.11.2016.
Lataaja: IP-käyttäjä. Vain Aalto-yliopisto käyttöön.



Reference number
ISO 13790:2008(E)

© ISO 2008

Tämä julkaisu on ladattu SFS Online-palvelusta (sop. nro) 07.11.2016.
Lataaja: IP-käyttäjä. Vain Aalto-yliopisto käyttöön.

PDF disclaimer

This PDF file may contain embedded typefaces. In accordance with Adobe's licensing policy, this file may be printed or viewed but shall not be edited unless the typefaces which are embedded are licensed to and installed on the computer performing the editing. In downloading this file, parties accept therein the responsibility of not infringing Adobe's licensing policy. The ISO Central Secretariat accepts no liability in this area.

Adobe is a trademark of Adobe Systems Incorporated.

Details of the software products used to create this PDF file can be found in the General Info relative to the file; the PDF-creation parameters were optimized for printing. Every care has been taken to ensure that the file is suitable for use by ISO member bodies. In the unlikely event that a problem relating to it is found, please inform the Central Secretariat at the address given below.

**COPYRIGHT PROTECTED DOCUMENT**

© ISO 2008

All rights reserved. Unless otherwise specified, no part of this publication may be reproduced or utilized in any form or by any means, electronic or mechanical, including photocopying and microfilm, without permission in writing from either ISO at the address below or ISO's member body in the country of the requester.

ISO copyright office
Case postale 56 • CH-1211 Geneva 20
Tel. + 41 22 749 01 11
Fax + 41 22 749 09 47
E-mail copyright@iso.org
Web www.iso.org

Published in Switzerland

Contents

Page

Foreword.....	v
Introduction	vi
1 Scope	1
2 Normative references	2
3 Terms and definitions	3
3.1 Time steps, periods and seasons	3
3.2 Spaces, zones and areas	3
3.3 Temperatures	4
3.4 Energy	5
3.5 Building heat transfer	7
3.6 Building heat gains and recoverable system thermal losses	7
3.7 Building energy balance	8
4 Symbols	8
5 Outline of the calculation procedures	11
5.1 Energy balance of building and systems	11
5.2 Main structure of calculation procedure	12
5.3 Different types of calculation method	15
5.4 Main characteristics of the different methods	15
5.5 Overall energy balances for building and systems	16
6 Definition of boundaries and zones	16
6.1 General	16
6.2 Boundary of the building for the calculation	17
6.3 Thermal zones	17
6.4 Determination of conditioned floor area, A_f	20
7 Building energy need for space heating and cooling	21
7.1 Calculation procedure	21
7.2 Energy need for heating and cooling	22
7.3 Multiple steps to integrate or isolate interactions	27
7.4 Length of heating and cooling seasons for operation of season-length-dependent provisions	29
8 Heat transfer by transmission	33
8.1 Calculation procedure	33
8.2 Total heat transfer by transmission per building zone	33
8.3 Transmission heat transfer coefficients	34
8.4 Input data and boundary conditions	37
9 Heat transfer by ventilation	38
9.1 Calculation procedure	38
9.2 Total heat transfer by ventilation per building zone — Seasonal or monthly method	38
9.3 Ventilation heat transfer coefficients	39
9.4 Input data and boundary conditions	45
10 Internal heat gains	47
10.1 Calculation procedure	47
10.2 Overall internal heat gains	47
10.3 Internal heat gain elements — All methods	49
10.4 Input data and boundary conditions	49
11 Solar heat gains	53

11.1	Calculation procedure	53
11.2	Overall solar heat gains.....	54
11.3	Solar heat gain elements	55
11.4	Input data and boundary conditions	57
12	Dynamic parameters	61
12.1	Calculation procedure	61
12.2	Dynamic parameters	62
12.3	Boundary conditions and input data	67
13	Indoor conditions	68
13.1	Different modes	68
13.2	Calculation procedures	69
13.3	Boundary conditions and input data	76
14	Energy use for space heating and cooling.....	76
14.1	Annual energy needs for heating and cooling, per building zone.....	76
14.2	Annual energy needs for heating and cooling, per combination of systems.....	76
14.3	Total system energy use for space heating and cooling and ventilation systems.....	77
15	Report.....	81
15.1	General.....	81
15.2	Input data	81
15.3	Results	82
Annex A (normative) Parallel routes in normative references.....		85
Annex B (normative) Multi-zone calculation with thermal coupling between zones		89
Annex C (normative) Full set of equations for simple hourly method.....		93
Annex D (normative) Alternative formulation for monthly cooling method.....		98
Annex E (normative) Heat transfer and solar heat gains of special elements.....		100
Annex F (normative) Climate-related data		111
Annex G (informative) Simplified methods and standard input data.....		113
Annex H (informative) Accuracy of the method		127
Annex I (informative) Explanation and derivation of monthly or seasonal utilization factors		136
Annex J (informative) Worked example; simple hourly and monthly methods		148
Annex K (informative) Flow charts of the calculation procedures		154
Bibliography		161

Foreword

ISO (the International Organization for Standardization) is a worldwide federation of national standards bodies (ISO member bodies). The work of preparing International Standards is normally carried out through ISO technical committees. Each member body interested in a subject for which a technical committee has been established has the right to be represented on that committee. International organizations, governmental and non-governmental, in liaison with ISO, also take part in the work. ISO collaborates closely with the International Electrotechnical Commission (IEC) on all matters of electrotechnical standardization.

International Standards are drafted in accordance with the rules given in the ISO/IEC Directives, Part 2.

The main task of technical committees is to prepare International Standards. Draft International Standards adopted by the technical committees are circulated to the member bodies for voting. Publication as an International Standard requires approval by at least 75 % of the member bodies casting a vote.

Attention is drawn to the possibility that some of the elements of this document may be the subject of patent rights. ISO shall not be held responsible for identifying any or all such patent rights.

ISO 13790 was prepared by Technical Committee ISO/TC 163, *Thermal performance and energy use in the built environment*, Subcommittee SC 2, *Calculation methods*, in cooperation with CEN/TC 89, *Thermal performance of buildings and building components*.

This second edition cancels and replaces the first edition (ISO 13790:2004), which has been technically revised. A summary of the principal changes is given below.

- Throughout, statements and equations that were true only for the heating mode have been amplified to accommodate both heating and cooling modes.
- Throughout, all texts that applied only for monthly or seasonal calculations have been amplified to accommodate hourly as well as monthly and seasonal calculations.
- The structure has been adapted to maximize the common use of procedures, conditions and input data, irrespective of the calculation method.
- A monthly (and seasonal) method for cooling, similar to the method in the first edition for heating, has been added.
- A simple hourly method for heating and cooling, to facilitate direct introduction of hourly, daily or weekly patterns (e.g. controls, user behaviour), has been added.
- For dynamic simulation methods, procedures that are consistent with the boundary conditions and input data for the seasonal, monthly and simple hourly methods have been added for the boundary conditions and input data.
- The whole document has been scrutinized to check its applicability within the context of building regulations, which require a minimum of ambiguities and subjective choices; where needed, possibilities are offered for national choices as given in national annexes, national building codes or national standards referring to this document, depending on the purpose/application of the calculations as detailed in this list and on the type or complexity of the building.

Introduction

This standard provides the means (in part) to assess the contribution that building products and services make to energy conservation and to the overall energy performance of buildings.

This International Standard has been prepared under a mandate given to CEN by the European Commission and the European Free Trade Association (Mandate M/343), and supports essential requirements of EU Directive 2002/91/EC on the energy performance of buildings (EPBD^[26]). It forms part of a series of standards aimed at European harmonization of the methodology for the calculation of the energy performance of buildings. An overview of the whole set of standards to support the EPBD is given in CEN/TR 15615 ^[28]. See also Annex A.

This International Standard is one of a series of calculation methods for the design and evaluation of thermal and energy performance of buildings. It presents a coherent set of calculation methods at different levels of detail, for the energy use for the space heating and cooling of a building, and the influence of the recoverable thermal losses of technical buildings systems such as the heating and cooling system.

In combination with other energy performance-related standards (see Figure 1, which gives an outline of the calculation procedure and its links with other energy performance-related standards), this International Standard can be used for the following applications:

- a) judging compliance with regulations expressed in terms of energy targets (via the design rating; see Annex A);
- b) comparing the energy performance of various design alternatives for a planned building;
- c) displaying a standardized level of energy performance of existing buildings (the standard calculated rating; see Annex A);
- d) assessing the effect of possible energy conservation measures on an existing building, by calculation of the energy use with and without the energy conservation measure; see Annex A;
- e) predicting future energy resource needs on a regional, national or international scale, by calculating the energy use of typical buildings representative of the building stock.

References are made to other International Standards or to national documents for input data and detailed calculation procedures not provided by this International Standard.

The main inputs needed for this International Standard are the following:

- transmission and ventilation properties;
- heat gains from internal heat sources, solar properties;
- climate data;
- description of building and building components, systems and use;
- comfort requirements (set-point temperatures and ventilation rates);
- data related to the heating, cooling, hot water, ventilation and lighting systems:
 - partition of building into different zones for the calculation (different systems may require different zones);
 - energy losses dissipated and recoverable or recovered in the building (internal heat gains, recovery of ventilation heat loss);
 - airflow rate and temperature of ventilation supply air (if centrally pre-heated or pre-cooled) and associated energy use for air circulation and pre-heating or pre-cooling;
 - controls.

The main outputs of this International Standard are the following:

- annual energy needs for space heating and cooling;
- annual energy use for space heating and cooling;
- length of heating and cooling season (for system running hours) affecting the energy use and auxiliary energy of season-length-dependent technical building systems for heating, cooling and ventilation.

Additional outputs are the following:

- monthly values of energy needs and energy use (informative);
- monthly values of main elements in the energy balance, e.g. transmission, ventilation, internal heat gains, solar heat;
- contribution of passive solar gains;
- system losses (from heating, cooling, hot water, ventilation and lighting systems), recovered in the building.

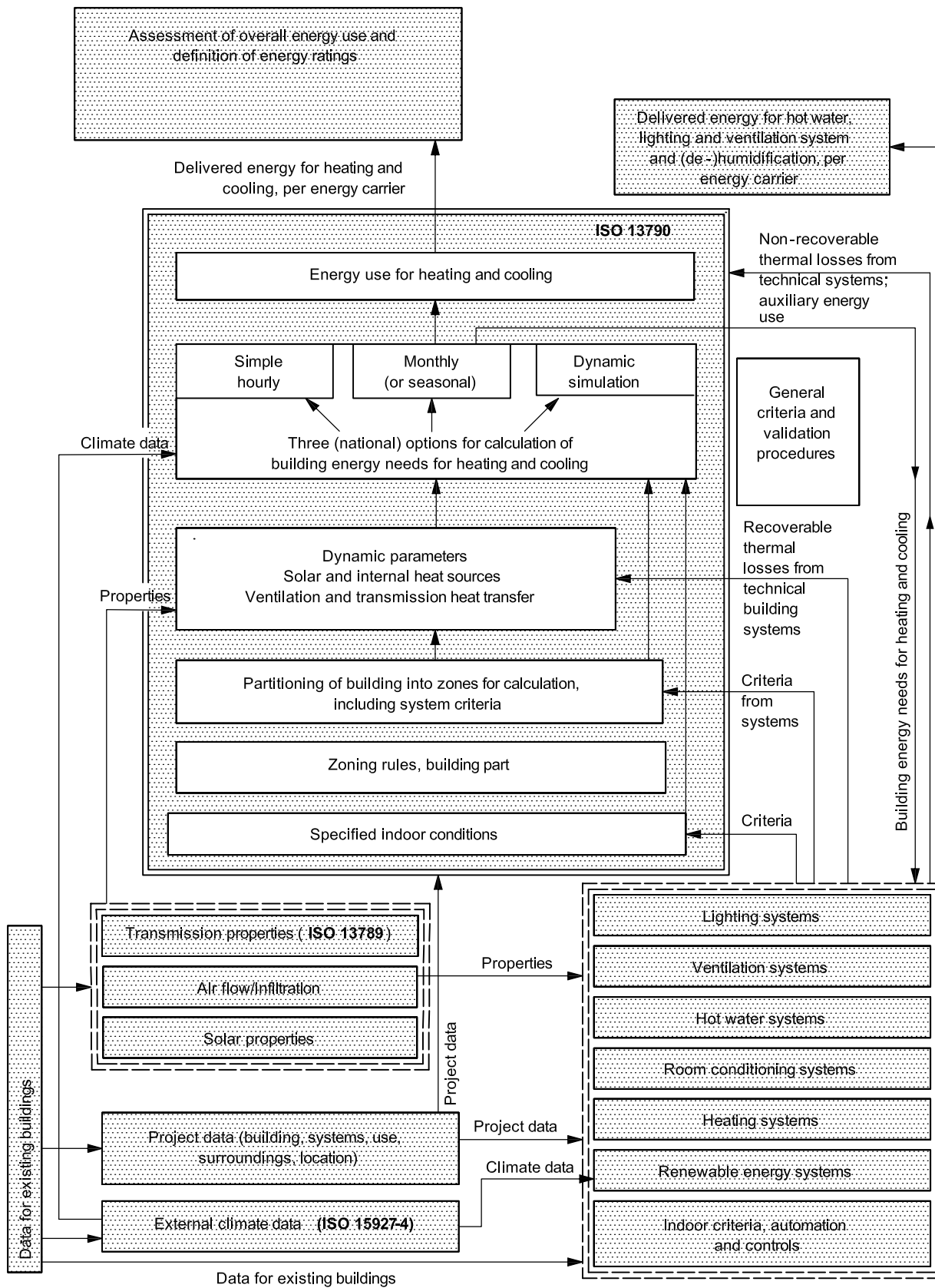

Figure 1 — Flow chart of calculation procedure and links with other standards

Energy performance of buildings — Calculation of energy use for space heating and cooling

1 Scope

This International Standard gives calculation methods for assessment of the annual energy use for space heating and cooling of a residential or a non-residential building, or a part of it, referred to as “the building”.

This method includes the calculation of:

- a) the heat transfer by transmission and ventilation of the building zone when heated or cooled to constant internal temperature;
- b) the contribution of internal and solar heat gains to the building heat balance;
- c) the annual energy needs for heating and cooling, to maintain the specified set-point temperatures in the building – latent heat not included;
- d) the annual energy use for heating and cooling of the building, using input from the relevant system standards referred to in this International Standard and specified in Annex A.

The building can have several zones with different set-point temperatures, and can have intermittent heating and cooling.

The calculation interval is either one month or one hour. For residential buildings, the calculation can also be performed on the basis of the heating and/or cooling season.

This International Standard also gives an alternative simple hourly method, using hourly user schedules (such as temperature set-points, ventilation modes or operation schedules of movable solar shading).

Procedures are given for the use of more detailed simulation methods to ensure compatibility and consistency between the application and results of the different types of method. This International Standard provides, for instance, common rules for the boundary conditions and physical input data, irrespective of the calculation approach chosen.

Special attention has been given to the suitability of this International Standard for use within the context of national or regional building regulations. This includes the calculation of an energy performance rating of a building, on the basis of standardized conditions, for an energy performance certificate. The result can have legal implications, in particular when it is used to judge compliance with minimum energy performance levels, which can, for instance, be required to obtain a building permit. For such applications, it is important that the calculation procedures be unambiguous, repeatable and verifiable. A special situation is the calculation of the energy performance in the case of old existing buildings, if gathering the full required input would be too labour-intensive for the purpose, relative to the cost-effectiveness of gathering the input. In this case, it is important that the calculation procedures provide the right balance between accuracy and data collection costs. To accommodate the application for these and other situations, this International Standard offers different choices. It is up to national bodies whether or not to choose a specific option for mandatory use, e.g. depending on the region in the country, the type of building and its use, and on the purpose of the assessment.

Annex H provides some information on the accuracy of the method.

ISO 13790:2008(E)

This International Standard has been developed for buildings that are, or are assumed to be, heated and/or cooled for the thermal comfort of people, but can be used for other types of building or other types of use (e.g. industrial, agricultural, swimming pool), as long as appropriate input data are chosen and the impact of special physical conditions on the accuracy is taken into consideration.

NOTE 1 For instance, it can be used when a special model is needed but is missing.

Depending on the purpose of the calculation, it may be decided nationally to provide specific calculation rules for spaces that are dominated by process heat (e.g. indoor swimming pool, computer/server room or kitchen in a restaurant).

NOTE 2 For instance, in the case of a building energy certificate and/or building permit, e.g. by ignoring the process heat or using default process heat for certain processes (e.g. shops: freezers, lighting in shop window).

The calculation procedures in this International Standard are restricted to sensible heating and cooling. The energy use due to humidification is calculated in the relevant standard on the energy performance of ventilation systems, as specified in Annex A; similarly, the energy use due to dehumidification is calculated in the relevant standard on the energy performance of space cooling systems, as specified in Annex A.

The calculation is not used to decide whether mechanical cooling is needed.

This International Standard is applicable to buildings at the design stage and to existing buildings. The input data directly or indirectly called for by this International Standard should be available from the building files or the building itself. If this is not the case, it is explicitly stated at relevant places in this International Standard that it may be decided at national level to allow for other sources of information. In this case, the user reports which input data have been used and from which source. Normally, for the assessment of the energy performance for an energy performance certificate, a protocol is defined at national or regional level to specify the type of sources of information and the conditions when they may be applied instead of the full required input.

2 Normative references

The following referenced documents are indispensable for the application of this document. For dated references, only the edition cited applies. For undated references, the latest edition of the referenced document (including any amendments) applies.

ISO 6946, *Building components and building elements — Thermal resistance and thermal transmittance — Calculation method*

ISO 7345, *Thermal insulation — Physical quantities and definitions*

ISO 10077-1, *Thermal performance of windows, doors and shutters — Calculation of thermal transmittance — Part 1: General*

ISO 13370:2007, *Thermal performance of buildings — Heat transfer via the ground — Calculation methods*

ISO 13786:2007, *Thermal performance of building components — Dynamic thermal characteristics — Calculation methods*

ISO 13789:2007, *Thermal performance of buildings — Transmission and ventilation heat transfer coefficients — Calculation method*

ISO 15927-4, *Hygrothermal performance of buildings — Calculation and presentation of climatic data — Part 4: Hourly data for assessing the annual energy use for heating and cooling*

EN 15217, *Energy performance of buildings — Methods for expressing energy performance and for energy certification of buildings*

3 Terms and definitions

For the purposes of this document, the terms and definitions in ISO 7345 and the following apply.

3.1 Time steps, periods and seasons

3.1.1

calculation step

discrete time interval for the calculation of the energy needs and uses for heating, cooling, ventilation, humidification and dehumidification

NOTE Typical discrete time intervals are one hour, one month or one heating and/or cooling season, operating modes and bins.

3.1.2

calculation period

period of time over which the calculation is performed

NOTE The calculation period can be divided into a number of calculation steps.

3.1.3

heating or cooling season

period of the year during which a significant amount of energy for heating or cooling is needed

NOTE 1 The lengths of the heating and cooling seasons are determined in different ways, depending on the calculation method. The season lengths are used to determine the operation period of technical systems or season-dependent user behaviour, for instance on ventilation.

NOTE 2 This International Standard includes a seasonal method that requires as calculation step a fixed season length that has to be distinguished from the actual season length.

3.1.4

unoccupied period

period of several days or weeks without heating or cooling, e.g. due to holidays

3.2 Spaces, zones and areas

3.2.1

heated space

room or enclosure, which for the purposes of a calculation is assumed to be heated to a given set-point temperature or set-point temperatures

3.2.2

cooled space

room or enclosure, which for the purposes of a calculation is assumed to be cooled to a given set-point temperature or set-point temperatures

3.2.3

conditioned space

heated and/or cooled space

NOTE The heated and/or cooled spaces are used to define the boundaries of the thermal zones and the thermal envelope.

3.2.4

unconditioned space

room or enclosure that is not part of a conditioned space

ISO 13790:2008(E)

3.2.5**conditioned zone**

part of a conditioned space with a given set-point temperature or set-point temperatures, throughout which the same occupancy pattern is assumed and the internal temperature is assumed to have negligible spatial variations, and which is controlled by a single heating system, cooling system and/or ventilation system, or by different systems with equal energy performance

3.2.6**conditioned area**

floor area of conditioned spaces excluding non-habitable cellars or non-habitable parts of a space, including the floor area on all storeys if more than one

NOTE 1 Internal, overall internal or external dimensions can be used. This leads to different areas for the same building.

NOTE 2 Some services, such as lighting or ventilation, might be provided to areas not included in this definition (e.g. a car park).

NOTE 3 The precise definition of the conditioned area is given by national authorities.

NOTE 4 "Conditioned area" can be taken as the useful area mentioned in the Clauses 5, 6 and 7 of the EPBD [26] unless it is otherwise defined in national regulations.

3.2.7**calculation with coupled zones**

multi-zone calculation with thermal coupling between zones, taking into account any heat transfer by thermal transmission and/or by ventilation and/or by air infiltration between zones

3.2.8**calculation with uncoupled zones**

multi-zone calculation without thermal coupling between zones, not taking into account any heat transfer by thermal transmission or by ventilation or by air infiltration between zones

3.2.9**projected area of solar collecting elements**

area of the projection of the surface of the element on to a plane parallel to the transparent or translucent part of the element

NOTE In the case of non-flat elements, this refers to the area of the imaginary of the smallest plane connecting the perimeter of the element.

EXAMPLE Windows.

3.2.10**projected area of frame elements**

area of the projection of the frame element on to a plane parallel to the glazing or panel that is held by the frame

EXAMPLE Window frames.

3.3 Temperatures**3.3.1****external temperature**

temperature of external air

NOTE 1 For transmission heat transfer calculations, the radiant temperature of the external environment is supposed equal to the external air temperature; long-wave radiation to the sky, from building elements facing the sky, is calculated separately (see 11.3.5 and/or 11.4.6).

NOTE 2 The measurement of external air temperature is defined in ISO 15927-1.

3.3.2

internal temperature

arithmetic average of the air temperature and the mean radiant temperature at the centre of a zone or space

NOTE This is the approximate operative temperature according to ISO 7726.

3.3.3

set-point (of the internal) temperature

internal (minimum intended) temperature as fixed by the control system in normal heating mode, or internal (maximum intended) temperature as fixed by the control system in normal cooling mode

NOTE The values are specified at national level, depending on the type of space and purpose of the calculation. See also definition of conditioned space (3.2.3). For monthly and seasonal methods, the value of the set-point can include adjustment for intermittency, as specified in 13.2.2.

3.3.4

set-back temperature

minimum internal temperature to be maintained during reduced heating periods, or maximum internal temperature to be maintained during reduced cooling periods

3.3.5

intermittent heating or cooling

heating or cooling pattern where normal heating or cooling periods alternate with periods of reduced or no heating or cooling

3.4 Energy

3.4.1

energy need for heating or cooling

heat to be delivered to, or extracted from, a conditioned space to maintain the intended temperature conditions during a given period of time

NOTE 1 The energy need is calculated and cannot easily be measured.

NOTE 2 The energy need can include additional heat transfer resulting from non-uniform temperature distribution and non-ideal temperature control, if they are taken into account by increasing (decreasing) the effective temperature for heating (cooling) and not included in the heat transfer due to the heating (cooling) system.

3.4.2

auxiliary energy

electrical energy used by technical building systems for heating, cooling, ventilation and/or domestic water to support energy transformation to satisfy energy needs

NOTE 1 This includes energy for fans, pumps, electronics, etc. Electrical energy input to a ventilation system for air transport and heat recovery is not considered as auxiliary energy, but as energy use for ventilation (3.4.11).

NOTE 2 In ISO 9488, the energy used for pumps and valves is called "parasitic energy".

3.4.3

technical building system

technical equipment for heating, cooling, ventilation, domestic hot water, lighting and electricity production

NOTE 1 A technical building system can refer to one or to several building services (e.g. heating system, heating and domestic hot water system).

NOTE 2 A technical building system is composed of different subsystems.

NOTE 3 Electricity production can include cogeneration and photovoltaic systems.

ISO 13790:2008(E)

3.4.4**technical building subsystem**

part of a technical building system that performs a specific function (e.g. heat generation, heat distribution, heat emission)

3.4.5**building services**

services provided by the technical building systems and by appliances to provide the indoor climate conditions, domestic hot water, illumination and other services related to the use of the building

3.4.6**system thermal loss**

thermal loss from a technical building system for heating, cooling, domestic hot water, humidification, dehumidification or ventilation that does not contribute to the useful output of the system

NOTE 1 A system loss can become an internal heat gain for the building if it is recoverable.

NOTE 2 Thermal energy recovered directly in the subsystem is not considered as a system thermal loss but as heat recovery and directly treated in the related system standard.

NOTE 3 Heat dissipated by the lighting system or by other services (e.g. appliances of computer equipment) is not part of the system thermal losses, but part of the internal heat gains.

3.4.7**recoverable system thermal loss**

part of a technical system thermal loss which can be recovered to lower either the energy need for heating or cooling or the energy use of the heating or cooling system

NOTE 1 This depends whether or not the recoverable system thermal losses are directly taken into account as a reduction to the system losses.

NOTE 2 In this International Standard, if not directly taken into account as a reduction to the system losses, the recoverable system thermal losses are calculated as part of the internal heat gains. It may be decided at national level to report the recoverable system thermal losses separately from the other internal heat gains.

3.4.8**recovered system thermal loss**

part of a recoverable system thermal loss which has been recovered to lower either the energy need for heating or cooling or the energy use of the heating or cooling system

NOTE This depends whether or not the recoverable system thermal losses are directly taken into account as a reduction to the system losses.

3.4.9**energy use for space heating or cooling**

energy input to the heating or cooling system to satisfy the energy need for heating or cooling, respectively

NOTE If the technical building system serves several purposes (e.g. heating and domestic hot water), it can be difficult to split the energy use into that used for each purpose. It can be indicated as a combined quantity (e.g. energy use for space heating and domestic hot water).

3.4.10**delivered energy for space heating or cooling**

energy, expressed per energy carrier, supplied to the technical building systems through the system boundary, to satisfy the uses taken into account (heating, cooling, ventilation, domestic hot water, lighting, appliances, etc.) or to produce electricity

NOTE 1 For active solar and wind energy systems the incident solar radiation on solar panels or on solar collectors, or the kinetic energy of wind is not part of the energy balance of the building.

NOTE 2 Delivered energy can be calculated or it can be measured.

3.4.11**energy use for ventilation**

electrical energy input to a ventilation system for air transport and heat recovery (not including energy input for pre-heating or pre-cooling the air) and energy input to a humidification system to satisfy the need for humidification

3.4.12**energy need for humidification and dehumidification**

latent heat in the water vapour to be delivered to, or extracted from, a conditioned space by a technical building system to maintain a specified minimum or maximum humidity within the space

3.4.13**energy use for other services**

electrical energy input to the appliances providing other services

NOTE This refers to services other than heating, cooling, domestic hot water, ventilation and lighting.

3.4.14**ventilation-heat recovery**

heat recovered from exhaust air to reduce the ventilation heat transfer

3.5 Building heat transfer**3.5.1****heat transfer coefficient**

heat flow rate divided by the temperature difference between two environments; specifically used for heat transfer coefficient by transmission or ventilation

NOTE In contrast with a heat gain, the driving force for heat transfer is the difference between the temperature in the considered space and the temperature of the environment at the other side (in the case of transmission) or the supply air temperature (in the case of ventilation).

3.5.2**transmission heat transfer coefficient**

heat flow rate due to thermal transmission through the fabric of a building, divided by the difference between the environment temperatures on either side of the construction

NOTE By convention, the sign is positive if the heat flow is going out of the space considered (heat loss).

3.5.3**ventilation heat transfer coefficient**

heat flow rate due to air entering an enclosed space, either by infiltration or ventilation, divided by the difference between the internal air temperature and the supply air temperature

NOTE The sign of the coefficient is always positive. By convention, the sign of the heat flow is positive if the supply air temperature is lower than the internal air temperature (heat loss).

3.6 Building heat gains and recoverable system thermal losses**3.6.1****heat gains**

heat generated within, or entering into, the conditioned space from heat sources other than energy intentionally utilized for heating, cooling or domestic hot water preparation

NOTE 1 These include internal heat gains and solar heat gains. Sinks that extract heat from the building are included as gains with a negative sign. In contrast with heat transfer, for a heat source (or sink) the difference between the temperature of the considered space and the temperature of the source is not the driving force for the heat flow.

NOTE 2 For summer conditions heat gains with a positive sign constitute extra heat load on the space.

ISO 13790:2008(E)

3.6.2**internal heat gains**

heat provided within the building by occupants (sensible metabolic heat) and by appliances such as domestic appliances, office equipment, etc., other than energy intentionally provided for heating, cooling or hot water preparation

NOTE 1 In this International Standard, if not directly taken into account as a reduction to the system losses, the recoverable system thermal losses are included as part of the internal heat gains. It may be decided at national level to report the recoverable system thermal losses separately.

NOTE 2 Included are heat from (warm) or to (cold) process sources that are not controlled for the purpose of heating or cooling or domestic hot-water preparation. The heat extracted from the building, from the indoor environment to cold sources (sinks), is included as gain with a negative sign.

3.6.3**solar heat gains**

heat provided by solar radiation entering, directly or indirectly (after absorption in building elements), into the building through windows, opaque walls and roofs, or passive solar devices such as sunspaces, transparent insulation and solar walls

NOTE Active solar devices such as solar collectors are considered as part of the technical building system.

3.6.4**useful heat gains**

proportion of internal and solar heat gains that contribute to reducing the energy need for heating

3.6.5**solar irradiation**

incident solar heat on a surface, per area of surface

3.7 Building energy balance**3.7.1****gain utilization factor**

factor reducing the total monthly or seasonal heat gains in the monthly or seasonal calculation method, to obtain the resulting reduction of the building energy need for heating

NOTE The factor can be applied in the monthly or seasonal calculation of the building energy need for cooling if the alternative method described in Annex D is used.

3.7.2**loss utilization factor**

factor reducing the total monthly or seasonal heat transfer in the monthly or seasonal calculation method, to obtain the resulting reduction of the energy need for cooling

NOTE The traditional term "loss", which originally referred to the heating mode only, is retained for the utilization factor for losses; if the losses are "negative", there is no utilization.

3.7.3**heat-balance ratio**

monthly or seasonal heat gains divided by the monthly or seasonal heat transfer

4 Symbols

Table 1 lists the symbols used in this International Standard.

Table 2 lists the subscripts used in this International Standard.

Table 1 — Symbols and units

Symbol	Quantity	Unit
A	area	m ²
a	numerical parameter in utilization factor	1
B	correction factor for an unconditioned adjacent space	1
C	effective heat capacity of a conditioned space	J/K
c	specific heat capacity	J/(kg·K)
d	layer thickness	m
E	energy	MJ
F	factor	1
g	total solar energy transmittance of a building element	1
H	heat transfer coefficient	W/K
h	surface coefficient of heat transfer	W/(m ² ·K)
I_{sol}	solar irradiance	W/m ²
L	length	m
N	number	1
Q	quantity of heat	MJ
q	heat flow density	W/m ²
q_v	(volumetric) airflow rate	m ³ /s
R	thermal resistance	m ² ·K/W
T	thermodynamic temperature	K
t	time, period of time	Ms ^a
U	thermal transmittance	W/(m ² ·K)
V	volume of air in a conditioned zone	m ³
Z	heat transfer parameter for solar walls	W/(m ² ·K)
α	absorption coefficient of a surface for solar radiation	1
γ	heat-balance ratio	1
ε	emissivity of a surface for long-wave thermal radiation	1
η	efficiency, utilization factor	1
θ	centigrade temperature	°C
κ	heat capacity per area	J/(m ² ·K)
κ_{SW}	factor related to heat losses of ventilated solar walls	1
A	dimensionless ratio between the internal surfaces area and the floor area (see 7.2.2.2)	1
ρ	density	kg/m ³
σ	Stefan-Boltzmann constant ($\sigma = 5,67 \times 10^{-8}$)	W/(m ² ·K ⁴)
τ	time constant	h
Φ	heat flow rate, thermal power	W
χ	point thermal transmittance	W/K
Ψ	linear thermal transmittance	W/(m·K)

^a Hours can be used as the unit of time instead of seconds for all quantities involving time (i.e. for time steps or periods as well as for air change rates), in which case the unit of energy is watt-hours (Wh) instead of joules. In most equations, megajoules are used instead of joules for quantities of heat or energy and megaseconds instead of seconds for time.

Table 2 — Subscripts

a	air	i	internal (temperature)	r _{vd}	recovered
A	appliances	<i>i,j,k,m,n</i>	dummy integers	<i>s</i>	designated space
adj	adjusted	in	input	se	surface external
an	annual	interm	intermittent	seas	seasonal
AO	accumulated overtemperature	int	internal (heat)	set	set-point
alt	altitude	is	conductance term ^a	sh	shading
at	coupling term ^a	L	lighting (system)	shut	shutter
aux	auxiliary	lat	latent	si	surface internal
avg	time average	ls	loss	sol	solar (heat gains)
bh	boost heating	m, <i>m</i>	monthly, designated month	ss	surface-sky average
c	structure, construction element	m	mass-related conductance or capacitance	sup	supply (of air)
d	design; daily, direct	met	metabolic	sys	system
C	cooling, capacity	mn	mean (time or space)	T	Thermal
C,nd	cooling need, or building need for cooling	ms	conductance term ^a	tb	Thermal bridge
c	convective	nd	need	Tot	Total (system)
calc	calculated	noc	unoccupied period	tot	total
corr	corrected	nrbl	non-recoverable	tr	transmission (heat transfer)
ctr	control	nr _{vd}	non-recovered		
cont	continuous	nren	non-renewable	u	unconditioned
day	daily	nut	non-utilized	ut	utilized
dif	diffuse	ob	obstacles		
dis	distribution	Oc	occupants	V	ventilation (system)
e	external, exterior, envelope	occ	occupied period	v	volume
el	electricity	off	off	ve	ventilation (heat transfer)
em	emission	on	on		
F	frame	op	opaque	W	hot water (system or need)
f	floor	o	overall	w	window
g	ground	P	related to power		
gl	glazing, glazed element	p	partition wall		
gn	gains	pp	peak power		
ht	heat transfer	ps	permanent shading	<i>y, z</i>	zone number
h	hourly	r	radiative		
hem	hemispherical	r _{vd}	recovered	⊥	perpendicular
H	heating	rbl	recoverable		
H,nd	heating need, or building need for heating	red	reduced	0	base; reference
HC,nd	heating and/or cooling need; building need for heating and/or cooling	ren	renewable		

^a For simple hourly method, see 7.2.2.

5 Outline of the calculation procedures

5.1 Energy balance of building and systems

5.1.1 Introduction

Depending on the situation, the building is partitioned into multiple zones or treated as a single zone.

The energy balance is split into the energy or heat balance at the building level and the energy balance at the system level.

The building energy needs for heating and sensible cooling of the building are calculated on the basis of the heat balance of the building zone(s).

These energy needs for heating and cooling are the input for the energy balance of the heating and cooling systems and ventilation systems.

A multi-step calculation can be required, which may be defined at national level, for instance to account for interactions between different zones (e.g. sharing the same system(s) and/or dissipation from the same system) or between the systems and the building energy balance (e.g. dissipated heat from systems affecting the heat balance of the building), see 7.3.

5.1.2 Energy balance at the building level

The energy (heat) balance at the building zone level includes the following terms (only sensible heat is considered):

- transmission heat transfer between the conditioned space and the external environment, governed by the difference between the temperature of the conditioned zone and the external temperature;
- ventilation heat transfer (by natural ventilation or by a mechanical ventilation system), governed by the difference between the temperature of the conditioned zone and the supply air temperature;
- transmission and ventilation heat transfer between adjacent zones, governed by the difference between the temperature of the conditioned zone and the internal temperature in the adjacent space;
- internal heat gains (including negative gains from heat sinks), for instance from persons, appliances, lighting and heat dissipated in, or absorbed by, heating, cooling, hot water or ventilation systems;
- solar heat gains (which can be direct, e.g. through windows, or indirect, e.g. via absorption in opaque building elements);
- storage of heat in, or release of stored heat from, the mass of the building;
- energy need for heating: if the zone is heated, a heating system supplies heat in order to raise the internal temperature to the required minimum level (the set-point for heating);
- energy need for cooling: if the zone is cooled, a cooling system extracts heat in order to lower the internal temperature to the required maximum level (the set-point for cooling).

NOTE The heat transfer to the external environment is negative when the external temperature is higher than the internal temperature.

The building energy balance may also include energy recovered in the building from various sources, such as recovered ventilation heat losses and recoverable losses from heating and cooling system.

The calculation procedures in this International Standard are restricted to sensible heating and cooling; see 5.1.3.

ISO 13790:2008(E)

In the heat balance over a longer period (e.g. a month), the net amount of heat stored in, or released from, the building mass, resulting from dynamic behaviour, becomes negligible.

5.1.3 Energy balance at the level of the technical building systems

The building energy need for heating and cooling is satisfied by the energy supply from the heating and cooling systems.

At the system level, the energy balance for heating and cooling, if applicable, includes:

- energy need for heating and cooling of the building zone;
- energy from renewable energy systems;
- generation, storage, distribution, emission and control losses of the space heating and cooling systems;
- energy input to the space heating and cooling systems;
- energy input to central pre-heating and pre-cooling of ventilation air, including transport, thermal losses and control;
- special: energy output from the space heating or cooling systems (e.g. exported electricity from a combined heat and power installation).

The system energy balance may also include energy recovered in the system from various sources.

The system energy use is described in Clause 14. More details on the energy use at system level are provided in the relevant system standards, as specified in Annex A.

The calculation procedures in this International Standard are restricted to sensible heating and cooling. The energy use due to humidification shall be calculated in accordance with the relevant standard on the energy performance of ventilation systems, as specified in Annex A; similarly, the energy use due to dehumidification shall be calculated in accordance with the relevant standard on the energy performance of space cooling systems, as specified in Annex A.

5.2 Main structure of calculation procedure

The main structure of the calculation procedure is summarised below. More details on the calculation procedures are presented in the relevant individual clauses.

- a) Choose the type of calculation method, in accordance with 5.3.
- b) Define the boundaries of the total of conditioned spaces and unconditioned spaces, in accordance with 6.2.
- c) If required, define the boundaries of the different calculation zones, in accordance with 6.3.
- d) Define the internal conditions for the calculations (Clause 13), the external climate (Annex F) and other environmental data inputs.
- e) Calculate, for each time step and building zone, the energy need for heating, $Q_{H,nd}$, and the energy need for cooling, $Q_{C,nd}$.
- f) Combine the results for different time steps and different zones serviced by the same systems and calculate the energy use for heating and for cooling taking into account the dissipated heat of the heating and cooling systems, in accordance with Clause 14.
- g) Combine the results for different building zones with different systems.

- h) Calculate the operational length of the heating and cooling season, in accordance with 7.4.
- i) It may be decided at national level, depending on the application and type of building, to require that the calculation of the energy need for heating and cooling is performed in multiple steps, for instance to account for interactions between the building and the system, or between adjacent zones. The procedures are given in 7.3.

Properties or (conservative) default values can be different for the heating and cooling mode.

With the monthly method, heating and cooling in the same month can be established by calculating 12 months heating mode and 12 months cooling mode.

For the calculation steps, see Figure 2. The numbers in circles refer to the successive calculation steps.

Illustrated for three zones,
with two sets of (H, C, V) systems servicing different zones

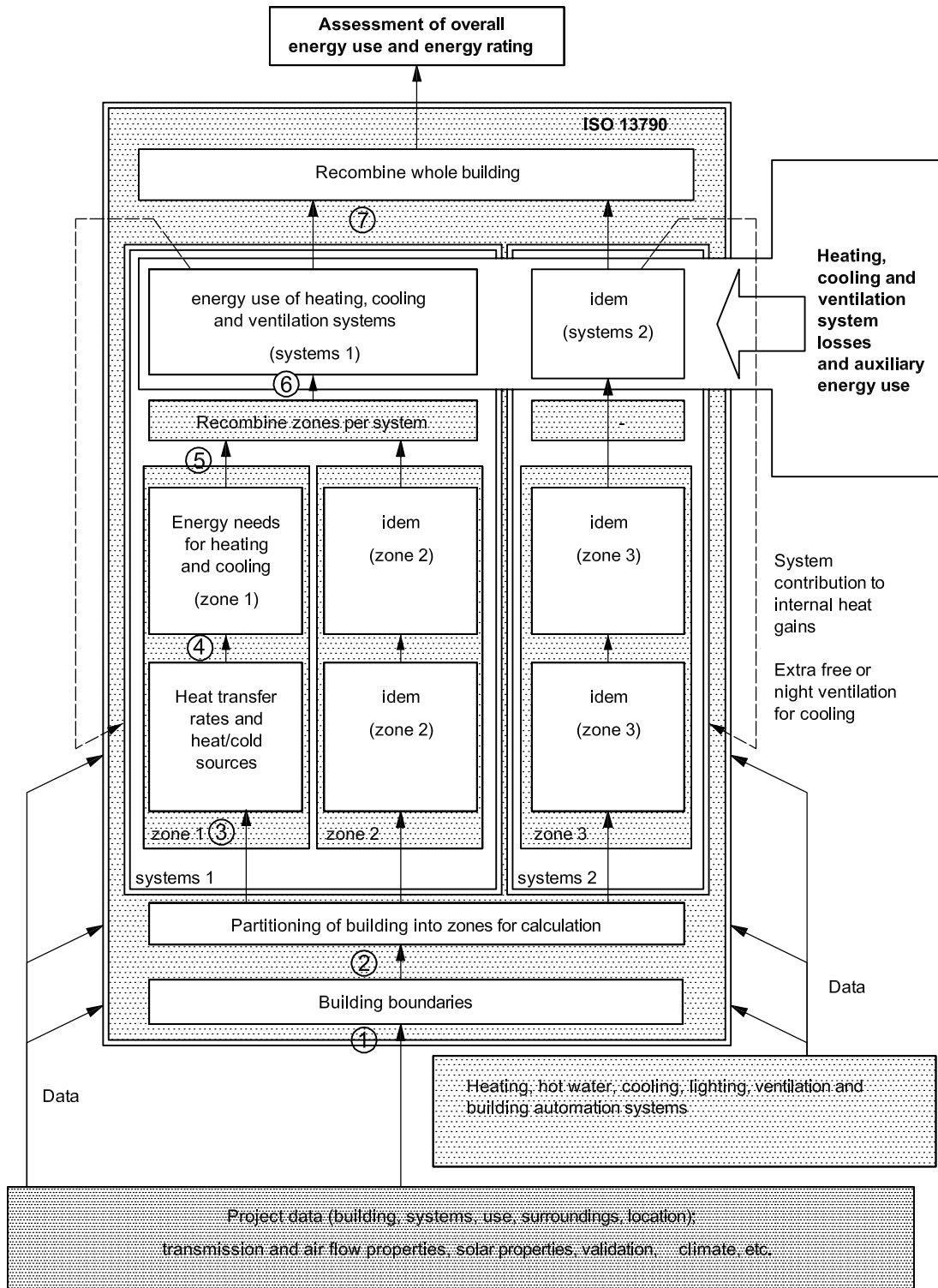

Figure 2 — Flow chart of main calculation steps

5.3 Different types of calculation method

There are two basic types of method:

- quasi-steady-state methods, calculating the heat balance over a sufficiently long time (typically one month or a whole season), which enables one to take dynamic effects into account by an empirically determined gain and/or loss utilization factor;
- dynamic methods, calculating the heat balance with short times steps (typically one hour) taking into account the heat stored in, and released from, the mass of the building.

This International Standard covers three different types of method:

- a fully prescribed monthly quasi-steady-state calculation method (plus, as a special option, a seasonal method);
- a fully prescribed simple hourly dynamic calculation method;
- calculation procedures for detailed (e.g. hourly) dynamic simulation methods.

The monthly calculation gives correct results on an annual basis, but the results for individual months close to the beginning and the end of the heating and cooling season can have large relative errors.

The alternative simple method for hourly calculations has been added to facilitate the calculation using hourly user schedules (such as temperature set-points, ventilation modes, operation schedule of movable solar shading and/or hourly control options based on outdoor or indoor climatic conditions). This method produces hourly results, but the results for individual hours are not validated and individual hourly values can have large relative errors.

The procedures for the use of more detailed simulation methods ensure compatibility and consistency between the application of different types of method. This International Standard provides common rules for the boundary conditions and physical input data, irrespective of the chosen calculation approach.

At national level, it may be decided which of these three types of method are mandatory or are allowed to be used, depending on the application (purpose of the calculation) and building type.

NOTE This choice typically depends on the use of the building (residential, office, etc.), the complexity of the building and/or systems, the application (energy performance requirement, energy performance certificate or recommended energy performance measures, other). See Annex H about the need to maintain a balance between accuracy, transparency, robustness and reproducibility.

5.4 Main characteristics of the different methods

5.4.1 Dynamic methods

In the dynamic methods, an instantaneous surplus of heat during the heating period has the effect that the internal temperature rises above the set-point, thus removing the surplus heat by extra transmission, ventilation and accumulation, if not mechanically cooled. Also, a thermostat set-back or switch-off might not lead directly to a drop in the internal temperature, due to the inertia of the building (heat released from the building mass). A similar situation applies to cooling.

A dynamic method models thermal transmission, heat flow by ventilation, thermal storage and internal and solar heat gains in the building zone. There are numerous methods to do so, ranging in complexity from simple to very detailed. There are other standards (e.g. EN 15265^[11]) describing detailed simulation methods or performance criteria for such methods. This International Standard provides the environment of standardized boundary conditions and standardized input and output data that enables compatibility and consistency between the different methods.

In this International Standard, one simple hourly method is fully specified: a three-node hourly method.

5.4.2 Quasi-steady-state methods

In the quasi-steady-state methods, the dynamic effects are taken into account by introducing correlation factors.

For heating, a utilization factor for the internal and solar heat gains takes account of the fact that only part of the internal and solar heat gains is utilized to decrease the energy need for heating, the rest leading to an undesired increase of the internal temperature above the set-point.

NOTE 1 See Annex I for a more detailed explanation of the concept of the gain utilization factor for heating.

The effect of thermal inertia in the case of intermittent heating or switch-off is taken into account separately; see Clause 13.

For cooling, there are two different ways to represent the same method:

- a) utilization factor for losses (mirror image of the approach for heating): a utilization factor for the transmission and ventilation heat transfer takes account of the fact that only part of the transmission and ventilation heat transfer is utilized to decrease the cooling needs, the "non-utilized" transmission and ventilation heat transfers occur during periods or intervals (e.g. nights) when they have no effect on the cooling needs occurring during other periods or moments (e.g. days);
- b) utilization factor for gains (similar as for heating): a utilization factor for the internal and solar heat gains takes account of the fact that only part of the internal and solar heat gains is compensated by thermal heat transfer by transmission and ventilation, assuming a certain maximum internal temperature. The other ("non-utilized") part leads to cooling needs, to avoid an undesired increase of the internal temperature above the set-point.

This International Standard specifies in the category of quasi-steady-state methods a monthly and seasonal method for heating and cooling following method a). The alternative formulation b) for the monthly cooling method is presented in Annex D.

NOTE 2 See Annex I for a more detailed explanation of the concept of the gain or loss utilization factors for cooling.

The effect of thermal inertia in the case of intermittent cooling or switch-off is taken into account separately; see Clause 13.

More details are given in 7.2.1.

5.5 Overall energy balances for building and systems

The main terms of the (time-averaged) energy balance for heating and cooling are schematically illustrated in a series of diagrams in Annex K.

6 Definition of boundaries and zones

6.1 General

The procedures in this clause apply to all calculation methods: seasonal, monthly, simple hourly and dynamic simulation methods.

First, the boundaries of the building for the calculation of energy needs for heating and cooling shall be defined (see 6.2).

Secondly, the building shall, if necessary, be divided into calculation zones (see 6.3).

For the purpose of energy performance rating, in accordance with the relevant standards as specified in Annex A, the calculated energy use for heating and/or cooling needs to be related to the floor area. In addition, some of the input values are not known for individual building zones and need to be proportionally allocated to the individual zones, for instance using the conditioned floor area of each zone as weighting factor. Finally, some input data are available at individual building-space level and need to be aggregated to building-zone level. In 6.4 are provided the calculation procedures for the conditioned floor area, which is consistent with the boundaries of the building and (if applicable) with the partitioning into zones.

6.2 Boundary of the building for the calculation

The boundary of the building for the calculation of the energy need for heating and/or cooling consists of all the building elements separating the conditioned space or spaces under consideration from the external environment (air, ground or water) or from adjacent buildings or unconditioned spaces.

Spaces that are not conditioned may be included within the boundary of the building, but in that case they shall be regarded as conditioned spaces.

6.3 Thermal zones

6.3.1 General

It may be necessary to partition a building into different zones, with separate calculation of the energy need for heating and cooling for each zone.

Depending on the conditions as specified in 6.3.2:

- the whole building may be modelled as a single zone;
- the building may be partitioned into several zones (multi-zone calculation), accounting for thermal coupling between the zones;
- the building may be partitioned into several zones (multi-zone calculation), taking no account of thermal coupling between the zones.

The criteria in 6.3.2 apply to all calculation methods (simple or detailed), but for detailed methods further partitioning can apply.

The boundary of a building zone consists of all the building elements separating the conditioned space or spaces under consideration from the external environment (air, ground or water) from adjacent conditioned zones, from adjacent buildings or from unconditioned spaces.

6.3.2 Criteria for partitioning into zones

6.3.2.1 Criteria for single-zone calculation

Small, unconditioned spaces may be included within a conditioned zone, but in that case they shall be regarded as conditioned spaces.

Partitioning of the building into thermal zones is not required if all of the following conditions apply to spaces within the building.

- a) Set-point temperatures for heating of the spaces differ by no more than 4 K.

NOTE 1 The set-point is the minimum temperature assumed for the calculation. Specifications are given in Clause 13.

- b) The spaces are all not mechanically cooled or all mechanically cooled and set-point temperatures for cooling of the spaces differ by no more than 4 K.

ISO 13790:2008(E)

- c) The spaces are serviced by the same heating system (if any) and the same cooling system (if any), in accordance with the relevant standards on heating and cooling systems respectively specified in Annex A.
- d) If there is a ventilation system or systems, in accordance with the relevant standard on ventilation systems specified in Annex A, at least 80 % of the floor areas of the spaces are serviced by the same ventilation system (the other spaces are then considered to be serviced by the main ventilation system).

NOTE 2 This 80 % rule is introduced to avoid the situation where it is necessary that extra zones be defined to cater for small spaces like corridors and storage rooms with different ventilation systems.

- e) The amount of ventilation in the spaces, expressed in cubic metres per square metre floor area per second, in accordance with the relevant standard on ventilation air flow specified in Annex A, differs by not more than a factor of 4 within 80 % of the floor area, or the doors between the spaces are likely to be frequently open.

NOTE 3 Zoning based on expected large differences in the heat-balance ratio for the heating mode or for the cooling mode is desirable, but not taken into account in the list above because the heat-balance ratio itself depends on the zoning and the calculation of the input data is too labour-intensive (especially in determining areas of building elements) to be done several times or room by room.

If one or more of these conditions does not apply, the building is divided into different zones in a way that all of the conditions apply to the individual zones. Further partitioning into smaller zones is allowed.

NOTE 4 Further partitioning may, for instance, be considered appropriate in the case of different occupancy, internal heat sources or lighting.

Rules for partitioning the building into thermal zones may also be defined at national level, for instance to take into account specific requirements of national or regional building regulations and/or to take into account the application.

Depending on the purpose of the calculation, it may be nationally decided to provide specific calculation rules for spaces that are dominated by process heat (e.g. indoor swimming pool, computer/servers room or a kitchen in a restaurant).

NOTE 5 For instance, in the case of a building energy certificate and/or building permit, ignoring the process heat or using default process heat for certain processes (e.g. shops: freezers, lighting in shop windows).

NOTE 6 For instance, to ensure reproducibility in the case of minimum energy performance requirements; to ensure the right balance between accuracy and costs in the case of inspection of an (old) existing building. See also Annex H.

NOTE 7 Within a specific building zone, there can still be heat dissipating from or to a distribution system of a heating or cooling system servicing another building zone that passes the zone under consideration.

The calculation procedure for a single-zone calculation is given in 6.3.3.1.

6.3.2.2 Criteria for multi-zone calculation without thermal coupling between zones

If the building is partitioned into different zones, it may be decided nationally whether it is allowed to calculate each zone independently using the single-zone procedure for each zone and assuming adiabatic boundaries between the zones. This is defined as a multi-zone calculation without thermal coupling between zones. The calculation procedure is given in 6.3.3.2.

NOTE The decision whether to ignore thermal coupling between zones can depend on the purpose of the calculation and/or the complexity of the building and its systems.

6.3.2.3 Criteria for multi-zone calculation with thermal coupling between zones

If neither the single-zone calculation nor the multi-zone calculation without thermal coupling between zones applies, the calculation shall be performed as a multi-zone calculation with thermal coupling between zones.

In order to comply with building regulations, it should be noted that a multi-zone calculation with interactions between the zones

- a) requires significantly more, and often arbitrary, input data (on transmission properties and air flow direction and size), and
- b) requires compliance with constraints in the building regulations on the zoning rules (freedom of internal partitioning, definitions of zoning in the case of combined use (e.g. a hospital generally also includes an office section, a restaurant section)).

A further complication can be the involvement of different heating, cooling and ventilation systems for different zones, which adds to the complexity and arbitrariness of the input and modelling.

The calculation procedures are given in 6.3.3.3.

6.3.3 Zone calculation

6.3.3.1 Single-zone calculation

6.3.3.1.1 Set-point temperatures

If the single-zone calculation applies, the set-point temperature, $\theta_{\text{int,H,set}}$, for heating of the building zone is given by Equation (1):

$$\theta_{\text{int,H,set}} = \frac{\sum_s A_{f,s} \theta_{\text{int,s,H,set}}}{\sum_s A_{f,s}} \quad (1)$$

where

$\theta_{\text{int,s,H,set}}$ is the set-point temperature for heating of space s , determined in accordance with Clause 13, expressed in degrees centigrade;

$A_{f,s}$ is the conditioned floor area of space s , determined in accordance with 6.4, expressed in square metres.

If the single-zone calculation applies, the set-point temperature, $\theta_{\text{int,C,set}}$, for cooling of the building zone is given by Equation (2):

$$\theta_{\text{int,C,set}} = \frac{\sum_s A_{f,s} \theta_{\text{int,s,C,set}}}{\sum_s A_{f,s}} \quad (2)$$

where

$\theta_{\text{int,s,C,set}}$ is the set-point temperature for cooling of space s , determined in accordance with Clause 13, expressed in degrees centigrade;

$A_{f,s}$ is the conditioned floor area of space s , determined in accordance with 6.4, expressed in square metres.

ISO 13790:2008(E)

The averaging is either on seasonal or monthly average data or on hourly data, depending on the type of method and the corresponding procedures in Clause 13.

6.3.3.1.2 Other input data

If the single-zone calculation applies and the zone contains spaces with different building use (internal heat gains, lighting hours, ventilation hours, ventilation rates, etc.) the area-weighted average values of the parameters related to building use shall be used, in the same way as is done for the set-point temperature.

The averaging is either on a seasonal or monthly basis, or hourly input data are used, depending on the type of method and the corresponding procedures in the relevant clauses.

6.3.3.2 Multi-zone calculation, no thermal coupling between zones

For a multi-zone calculation without thermal coupling between zones (calculation with uncoupled zones), no heat transfer by thermal transmission or by air movement between the zones is taken into account.

The calculation with uncoupled zones is regarded as an independent series of single-zone calculations.

For zones sharing the same heating and cooling system, the energy need for heating and cooling is the sum of the energy need calculated for the individual zones (see Clause 14).

For zones not sharing the same heating and cooling system, the energy use for the building is the sum of the energy use calculated for the individual zones (see Clause 14).

6.3.3.3 Multi-zone calculation, thermal coupling between zones

For a multi-zone calculation with thermal coupling between zones (calculation with coupled zones), any heat transfer (by thermal transmission or by air movement) is taken into account.

The procedures for a calculation with coupled zones are given in Annex B.

NOTE See 6.3.2.3 for this type of calculation. The procedure is normally used only for special situations.

6.4 Determination of conditioned floor area, A_f

The floor area within the boundary of the building is the conditioned floor area, A_f , of the building (see 3.2). The type of dimension system used to calculate A_f (internal dimensions, external dimensions or overall internal dimensions) may be determined at national level, but it is necessary that it be specified. The same applies to possible parts of the floor area within the boundary of the building that are or are not part of the conditioned floor area, A_f .

NOTE Parts of the floor area within the boundary of the building that, possibly, are not part of the conditioned floor area, A_f , are, for example, areas of the floor where the space has a height less than a specified height, and the area of supporting walls. Parts of the floor area within the boundary of the building that, possibly, are part of the conditioned floor area, A_f , are, for example, the area of non-supporting walls.

If applicable, the conditioned floor area of a building zone is determined similarly for each calculation zone in the building. The sum of conditioned floor areas of all zones shall be equal to the conditioned floor area of the building.

If necessary, the conditioned floor area of a space in the building zone is determined similarly for each space in the building zone. The sum of conditioned floor areas of all spaces in the building zone shall be equal to the conditioned floor area of the building zone.

7 Building energy need for space heating and cooling

7.1 Calculation procedure

The calculation procedure depends on the type of calculation method, but the assumptions (of environment conditions, user behaviour and controls) and the basic physical data shall be the same for each of the types of calculation methods (seasonal, monthly, simple hourly and detailed simulation methods).

There are three steps of the calculation:

- 1) calculation of the energy need for heating and cooling;
- 2) calculation of the season length for the operation of season-length-dependent provisions;
- 3) possible repetition of the calculation due to the interaction of the building and system, or for other informative or normative reasons as specified in the relevant clause.

See Table 3.

Table 3 — Calculation procedure for the energy need for space heating and cooling for the different types of method

Type of method	Calculation of energy need for heating and cooling	Calculation of season length for operation of provisions	Multiple steps
Seasonal or monthly method	7.2.1	7.4	7.3
Simple hourly method	7.2.2	7.4	7.3
Detailed simulation method	7.2.3	7.4	7.3

The calculation procedure to obtain the energy need for space heating and cooling of the building zone is summarised in the following list. This part of the procedure describes in more detail steps d) and e) of the main calculation procedure as presented in 5.2.

- a) Calculate the internal conditions in accordance with Clause 13, the climate conditions in accordance with Annex F and other relevant environmental data inputs.
- b) Calculate the characteristics for the heat transfer by transmission, in accordance with Clause 8.
- c) Calculate the characteristics for the heat transfer by ventilation, in accordance with Clause 9.
- d) Calculate the internal heat gains, in accordance with Clause 10.
- e) Calculate the solar heat gains, in accordance with Clause 11.
- f) Calculate the dynamic parameters, in accordance with Clause 12.

With the monthly method, heating and cooling in the same month can be established by calculating 12 months heating mode and 12 months cooling mode, each with own parameter values (e.g. ventilation, heat recovery, etc.).

7.2 Energy need for heating and cooling

7.2.1 Monthly and seasonal methods

7.2.1.1 Energy need for heating

For each building zone and each calculation step (month or season), the building energy need for space heating, $Q_{H,nd}$, for conditions of continuous heating, is calculated as given by Equation (3):

$$Q_{H,nd} = Q_{H,nd,cont} = Q_{H,ht} - \eta_{H,gn} Q_{H,gn} \quad (3)$$

where (for each building zone, and for each month or season)

$Q_{H,nd,cont}$ is the building energy need for continuous heating, assumed to be greater than or equal to 0, expressed in megajoules;

$Q_{H,ht}$ is the total heat transfer for the heating mode, determined in accordance with 7.2.1.3, expressed in megajoules;

$Q_{H,gn}$ gives the total heat gains for the heating mode, determined in accordance with 7.2.1.3, expressed in megajoules;

$\eta_{H,gn}$ is the dimensionless gain utilization factor, determined in accordance with 12.2.1.

For each building zone and each calculation step (month or season), the building energy need for space heating, $Q_{H,nd}$, for conditions of intermittent heating, if the conditions of 13.1 apply, is given by Equation (4):

$$Q_{H,nd} = Q_{H,nd,interm} \quad (4)$$

where $Q_{H,nd,interm}$ is determined in accordance with 13.2.2.

For situations with a long unoccupied period, $Q_{H,nd}$ is determined with the correction in accordance with 13.2.4.

The latent energy need for humidification is not included in this calculation.

NOTE 1 The gain utilization factor, $\eta_{H,gn}$, is explained in 5.4.2. It is a function mainly of the heat-balance ratio and the thermal inertia of the building, as illustrated in Figure 5.

The calculation step for the seasonal method shall be the fixed heating season length, as explained in 7.2.1.4. For the monthly method, the calculation step is 1 month.

NOTE 2 1.3 provides a method for determining the fixed season length for the seasonal method.

7.2.1.2 Energy need for cooling

For each building zone and each calculation step (month or season), the energy need for space cooling, $Q_{C,nd}$, for conditions of continuous cooling, is calculated in accordance with Equation (5):

$$Q_{C,nd} = Q_{C,nd,cont} = Q_{C,gn} - \eta_{C,ls} Q_{C,ht} \quad (5)$$

where (for each building zone, and for each month or season)

$Q_{C,nd,cont}$ is the building energy need for continuous cooling, assumed to be greater than or equal to 0, expressed in megajoules;

$Q_{C,ht}$ is the total heat transfer for the cooling mode, determined in accordance with 7.2.1.3, expressed in megajoules;

$Q_{C,gn}$ gives the total heat gains for the cooling mode, determined in accordance with 7.2.1.3, expressed in megajoules;

$\eta_{C,ls}$ is the dimensionless utilization factor for heat losses, determined in accordance with 12.2.1.

For each building zone and each calculation step (month or season), the building energy need for space cooling, $Q_{C,nd}$, for conditions of intermittent cooling, if the conditions of 13.1 apply, is given by Equation (6):

$$Q_{C,nd} = Q_{C,nd,interm} \quad (6)$$

where $Q_{C,nd,interm}$ is determined in accordance with 13.2.2.

For situations with a long unoccupied period, $Q_{C,nd}$ is determined with the correction in accordance with 13.2.4.

The energy need for latent cooling (dehumidification) is not included in this calculation.

NOTE 1 The principle of the utilization factor for losses, $\eta_{C,ls}$, is explained in 5.4.2 [cooling, method a)]. It is a function mainly of the heat-balance ratio and thermal inertia of the building as illustrated in Figure 6. A negative value for $Q_{C,ht}$ is allowed: in that case the utilization factor has the value 1 and, consequently, the negative losses are added as gains.

The calculation step for the seasonal method shall be the fixed cooling season length, as explained in 7.2.1.4. For the monthly method, the calculation step is 1 month.

NOTE 2 1.3 provides a method for determining the fixed season length for the seasonal method.

7.2.1.3 Total heat transfer and heat gains

For each building zone and each calculation step (month or season), the total heat transfer, Q_{ht} , is given by Equation (7):

$$Q_{ht} = Q_{tr} + Q_{ve} \quad (7)$$

where (for each building zone and for each calculation step)

Q_{tr} is the total heat transfer by transmission, determined in accordance with Clause 8, expressed in megajoules;

Q_{ve} is the total heat transfer by ventilation, determined in accordance with Clause 9, expressed in megajoules.

The total heat gains, Q_{gn} , of the building zone for a given calculation step, are calculated using Equation (8):

$$Q_{gn} = Q_{int} + Q_{sol} \quad (8)$$

where (for each building zone and for each calculation step)

Q_{int} is the sum of internal heat gains over the given period, determined in accordance with Clause 10, expressed in megajoules;

Q_{sol} is the sum of solar heat gains over the given period, determined in accordance with Clause 11, expressed in megajoules.

7.2.1.4 Seasonal method — fixed length of heating and cooling season for the heat balance calculation

The fixed length of the heating season is needed for the calculation of total heat transfer and total heat gains during the heating season. This fixed length is directly linked to the parameters that determine the values of the gain utilization factor (see 12.2.1).

ISO 13790:2008(E)

This length may be determined at national level. Annex I contains a method that may be used to determine the fixed length of the heating and the cooling season for the seasonal method.

7.2.2 Simple hourly method

7.2.2.1 Principle

The model is a simplification of a dynamic simulation, with the following intention:

- same level of transparency, reproducibility and robustness as the monthly method:
 - clearly specified, limited set of equations, enabling traceability of the calculation process;
 - reduction of the input data as much as possible;
 - unambiguous calculation procedures;
- with main advantage over the monthly method that the hourly time intervals enable direct input of hourly patterns.

NOTE 1 The advantages and disadvantages of the simple hourly versus monthly method are described in more detail in Annex H and in the Bibliographic Reference [24].

In addition, the model

- makes new development easy by using directly the physical behaviour to be implemented,
- keeps an adequate level of accuracy, especially for room-conditioned buildings where the thermal dynamic of the room behaviour is of high impact.

The model used is based on an equivalent resistance-capacitance (R-C) model. It uses an hourly time step and all building and system input data can be modified each hour using schedule tables (in general, on a weekly basis).

The model makes a distinction between the internal air temperature and mean temperature of the internal (building zone facing) surfaces (mean radiant temperature). This enables its use in principle for thermal comfort checks and increases the accuracy of taking into account the radiative and convective parts of solar, lighting, and internal heat gains, although the results of the simple method at hourly level are not reliable.

The calculation method is based on simplifications of the heat transfer between the internal and external environment, as shown in Figure 3.

The heating and/or cooling need is found by calculating for each hour the need for heating or cooling power, $\Phi_{HC,nd}$ (positive for heating and negative for cooling), that needs to be supplied to, or extracted from, the internal air node, θ_{air} , to maintain a certain minimum or maximum set-point temperature. The set-point temperature is a weighted mean of air and mean radiant temperature. The default weighting factor is 0,5 for each.

Heat transfer by ventilation, H_{ve} , is connected directly to the air temperature node, θ_{air} , and to the node representing the supply air temperature, θ_{sup} . Heat transfer by transmission is split into the window part, $H_{tr,w}$, taken as having zero thermal mass, and the remainder, $H_{tr,op}$, containing the thermal mass which in turn is split into two parts: $H_{tr,em}$ and $H_{tr,ms}$. Solar and internal heat gains are distributed over the air node, θ_{air} , the central node, θ_s (a mix of θ_{air} and mean radiant temperature $\theta_{r,mn}$) and the node representing the mass of the building zone, θ_m . The thermal mass is represented by a single thermal capacity, C_m , located between $H_{tr,ms}$ and $H_{tr,em}$. A coupling conductance is defined between the internal air node and the central node. The heat flow rate due to internal heat sources, Φ_{int} , and the heat flow rate due to solar heat sources, Φ_{sol} , are split amongst the three nodes.

NOTE 2 “Window part” is here a generic term. It also includes doors and all glazed elements of the building envelope, but none of the insulated opaque components.

The hourly energy needs for heating and/or cooling, $Q_{\text{HC,nd}}$, expressed in megajoules, are obtained by multiplying $\Phi_{\text{HC,nd}}$, expressed in watts, by 0,036. Similarly, the internal and solar heat gains, Q_{int} and Q_{sol} , expressed in megajoules, are obtained by multiplying Φ_{int} and Φ_{sol} respectively, expressed in watts, by 0,036.

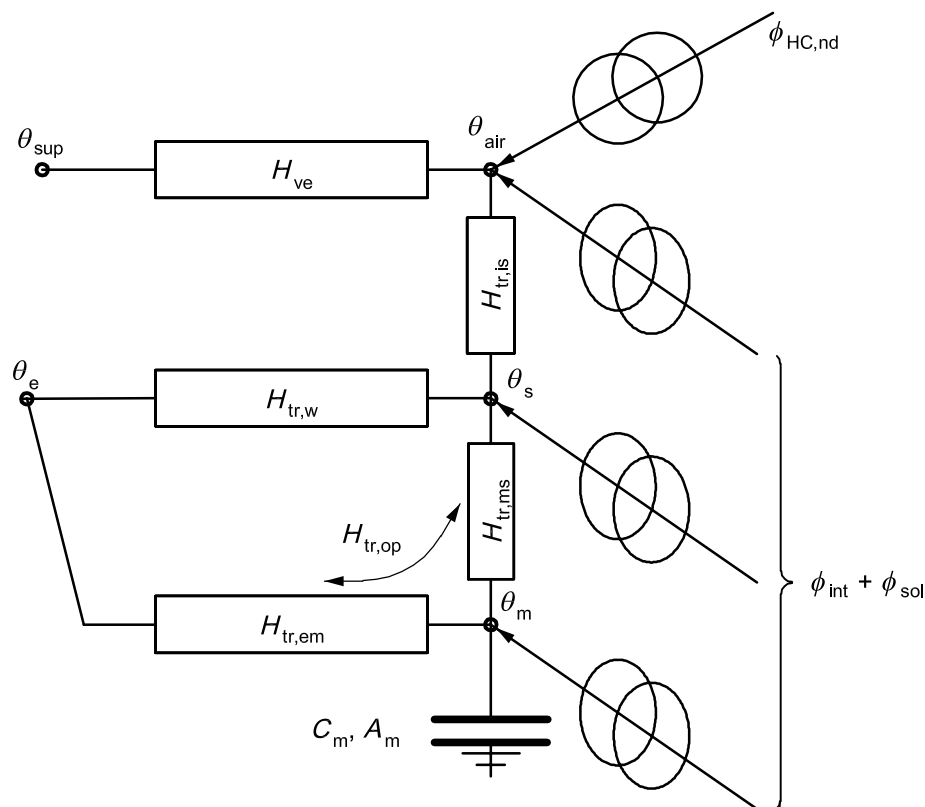

Figure 3 — Five resistances, one capacitance (5R1C) model

7.2.2.2 Main variables

The main variables for the model are the following:

- the thermal transmission coefficients, $H_{\text{tr,w}}$, of doors, windows, curtain walls and glazed walls and $H_{\text{tr,op}}$, of opaque building elements obtained from 8.3 and split into $H_{\text{tr,em}}$ and $H_{\text{tr,ms}}$ in accordance with 12.2.2;
- the ventilation characteristics, H_{ve} and θ_{sup} , obtained from 9.3;
- the coupling conductance, $H_{\text{tr,is}}$;
- the internal heat capacity, C_m , is obtained from 12.3.1, expressed in joules per kelvin.

The coupling conductance, $H_{\text{tr,is}}$, expressed in watts per kelvin, between the air node, θ_{air} , and the surface node, θ_s , is as given by Equation (9):

$$H_{\text{tr,is}} = h_{\text{is}} A_{\text{tot}} \quad (9)$$

where

h_{is} is the heat transfer coefficient between the air node, θ_{air} , and the surface node, θ_s , with a fixed value of $h_{\text{is}} = 3,45 \text{ W}/(\text{m}^2 \cdot \text{K})$;

ISO 13790:2008(E)

A_{tot} is the area of all surfaces facing the building zone, equal to $A_{\text{at}} \times A_{\text{f}}$, expressed in square metres;

A_{f} is the conditioned floor area, in accordance with 6.4, expressed in square metres;

A_{at} is the dimensionless ratio between the internal surfaces area and the floor area; A_{at} can be assumed to be equal to 4,5.

For a given hour, all values are known except $\Phi_{\text{HC,nd}}$, which it is necessary to calculate.

Full details are given in the respective clauses. The full set of equations is given in Annex C.

The monthly heating and cooling energy need is obtained by summing the hourly heating and cooling energy need, as described in 14.1.

7.2.2.3 Calculation of heat flows from internal and solar heat sources

As shown in C.2, the heat flows from internal and solar heat sources are split between the air node, θ_{airt} , and the internal nodes, θ_{int} , θ_{m} as given by Equations (C.1), (C.2) and (C.3).

The heat flow rate from internal heat sources Φ_{int} is obtained from 10.2 and the heat flow rate from solar heat sources, Φ_{sol} , is obtained from 11.2.

A_{t} is obtained from 7.2.2.2 and A_{m} is obtained from 12.2.2.

7.2.3 Detailed simulation method

Dynamic methods used for the calculation of energy need of heating and cooling shall have passed the validation tests in accordance with the relevant standards containing validation tests for detailed simulation methods as specified in Annex A.

In addition, for the aspects not covered by the validation tests, in the case of comparison of the energy performance level of buildings and/or for checking compliance with national or regional building regulations, the procedure shall be used as prescribed, or referred to, in this International Standard.

Consequently, the calculation shall be performed according to the following:

- partitioning into zones, see 6.3;
- transmission heat transfer characteristics, see Clause 8;
- ventilation heat transfer characteristics, see Clause 9;
- internal heat gains, see Clause 10;
- solar heat gains, see Clause 11;
- dynamic parameters, see Clause 12;
- internal conditions, see Clause 13.

NOTE In particular when the calculation results are to be used in the context of checking for compliance with building regulations it is important that calculation tools are checked in full detail on compliance with the general procedures, boundary conditions and input data. If there is a conflict with the procedures in this International Standard, this may lead to differences in the results that remain undetected and therefore lead to variability of results. Such tools are in general difficult to check. Relevant aspects include:

- (dynamic) heat transfer via the ground, including thermal bridges;
- non-adiabatic internal walls and floors;
- linear thermal bridges;
- air flows between building zones;
- solar shading by, and reflection from, overhangs, fins and external obstacles;
- angle-dependent solar properties of windows;
- hourly calculation of air infiltration.

7.3 Multiple steps to integrate or isolate interactions

7.3.1 Type of method and purpose

Due to interactions between building and system, between zones and/or other interactions, multiple steps may be required for the calculation.

If the purpose is to take the interaction into account, these iterations are, if possible, performed at the smallest time interval of the calculation, depending on the type of calculation method: hour, month or season.

If the purpose is to isolate the effect of the interaction, these iterations shall be performed on a monthly or seasonal basis.

7.3.2 To account for interaction between building and systems

The heat gains (including negative gains, from heat sinks) comprise the heat losses from the heating and cooling system. Before the dissipated heat from the heating and cooling system can be calculated, it might be necessary to calculate first the energy needs for heating and cooling without these elements in the internal heat gains.

With this information, the dissipated heat from the heating and cooling system can be calculated, followed by a second and final calculation of the energy needs for heating and cooling.

NOTE 1 In principle, a full iteration would be required, but a full iteration will usually not lead to an improvement of the overall accuracy of the result and a two-step approach suffices.

NOTE 2 The result of the first step also gives insight into the performance of the building without the influence of the heating and cooling system.

Consequently, depending on the application and type of building it may be decided at national level to require that the calculation of the energy need for heating and cooling is performed in two or more steps: first a calculation without dissipated heat from the heating and cooling system (when this cannot be predicted without knowing the heating and cooling needs), followed by a calculation or iteration including dissipated heat from the heating and cooling system, based on the information from the first calculation.

Optionally, other internal heat gain sources (positive or negative) may be subjected to the same procedure to quantify (isolate) their effect on the energy needs for heating and cooling.

ISO 13790:2008(E)

NOTE 3 The result will depend on the order in which the internal heat gains are added to the calculation. Moreover, the effect on the energy needs can be misleading; for instance, the internal heat gains from lighting will lead to a decrease in energy need for heating (winter) and increase of energy need for cooling (summer). However, in many cases it is more relevant to try to prevent summer cooling, e.g. by an investment in a free cooling or night-time ventilation system and/or extra solar shading provisions; in that case the impact on the energy need for cooling is zero, but the impact on the investment costs is significant, though this penalty is not shown.

In the case of a single-step calculation, it may also be decided at national level to apply a simplified approach. One way is to adjust specific system losses directly at the system level to account for recovered losses at building level and disregard these as input in the building energy balance. Another is to make estimates of the recoverable system losses and include these in the internal heat gains for the building part of the calculation.

NOTE 4 The first option can lead to significant errors if the effect of the recoverable losses on the building energy balance is large or strongly different from the situation on which the adjustment was based.

7.3.3 To quantify seasonal special provisions

Similarly, depending on the application and type of building, it may be decided at national level to require that the calculation of the energy need for cooling is performed in two or more steps: first a calculation without free cooling or night-time cooling by ventilation, followed by a calculation with free cooling or night-time cooling by ventilation for those periods where the first calculation indicated that one or both of these are feasible options to decrease the energy need for cooling.

7.3.4 To quantify the effect of imperfect temperature control

It may also be nationally decided to repeat the calculation with variations on the input data to quantify effects of imperfect temperature control.

7.3.5 To account for interaction between zones

In the case of a multi-zone calculation with thermally coupled zones in accordance with 6.3.2.3, iteration is also required.

7.3.6 To obtain breakdown into components

Optionally, it may also be relevant to repeat the overall calculation, e.g. by successively excluding specific elements in the calculation, to quantify the effect of specific elements on the result. In particular:

- the building energy need for heating and cooling in the absence of a heat recovery unit in a mechanical ventilation system; this will provide a result more closely related to the performance of the building itself, although a complete separation will not be possible, because the building will still contain specific design choices related to heat recovery, such as a higher air tightness;
- the passive solar energy gains by replacing the windows (and any sunspace or other passive solar provision) by a reference set of windows having a reference (neutral) orientation, size and (optionally) a reference thermal transmittance; similarly passive cooling techniques.

NOTE Warning: when a number of alternative energy saving measures are being considered, the order in which the measures are successively added in the calculation will affect the calculated individual effect of each measure.

7.4 Length of heating and cooling seasons for operation of season-length-dependent provisions

7.4.1 Monthly method

7.4.1.1 Heating season

In the absence of a national method, the actual length of heating season to determine the number of hours of operation of certain season-length-dependent provisions (e.g. pumps, fans, central pre-heating; see 14.3) can be determined as follows.

The actual length of the heating season, L_H , expressed in the number of months, is calculated by using Equation (10):

$$L_H = \sum_{m=1}^{m=12} f_{H,m} \quad (10)$$

where $f_{H,m}$ is the fraction of the month that is part of the heating season.

Determine $f_{H,m}$ for each month according to one of the following two methods:

- method a: simplified method, on the basis of the ratio between the energy need for heating and cooling;
- method b: on the basis of the monthly values for the heat-balance ratio for the heating mode, γ_H , determined in accordance with 12.2.1.1.

Method a:

The fraction of the month that is part of the heating season, is calculated by using Equation (11):

$$f_H = Q_{H,nd} / (Q_{H,nd} + Q_{C,nd} + Q_{V,pre-heat} + Q_{V,pre-cool}) \quad (11)$$

where

$Q_{H,nd}$	is the monthly energy need for heating, expressed in megajoules, determined in accordance with 7.2.1.1;
$Q_{C,nd}$	is the monthly energy need for cooling, expressed in megajoules, determined in accordance with 7.2.1.2;
$Q_{V,pre-heat}$	is the energy need for pre-heating of ventilation air, expressed in megajoules, determined in accordance with 9.3.3.12;
$Q_{V,pre-cool}$	is the energy need for pre-cooling of ventilation air, expressed in megajoules, determined in accordance with 9.3.3.12.

Method b:

Determine first the limit value of the dimensionless heat-balance ratio for the heating mode, $\gamma_{H,lim}$, as given by Equation (12):

$$\gamma_{H,lim} = (a_H + 1) / a_H \quad (12)$$

where a_H is a dimensionless numerical parameter depending on the time constant of the building, determined in accordance with 12.2.1.1.

NOTE The value for $\gamma_{H,lim}$ corresponds to the point at the *ideal* gain utilization curve with gain utilization factor equal to the *actual* gain utilization factor at $\gamma_H = 1$. A lower curve (less utilization, lower a_H) leads to a higher limit; in an ideal situation the limit is $\gamma_{H,lim} = 1$: the gain utilization factor = 1 and the monthly heat gains are just enough to compensate the monthly heat losses by transmission and ventilation heat transfer. See Figure 4.

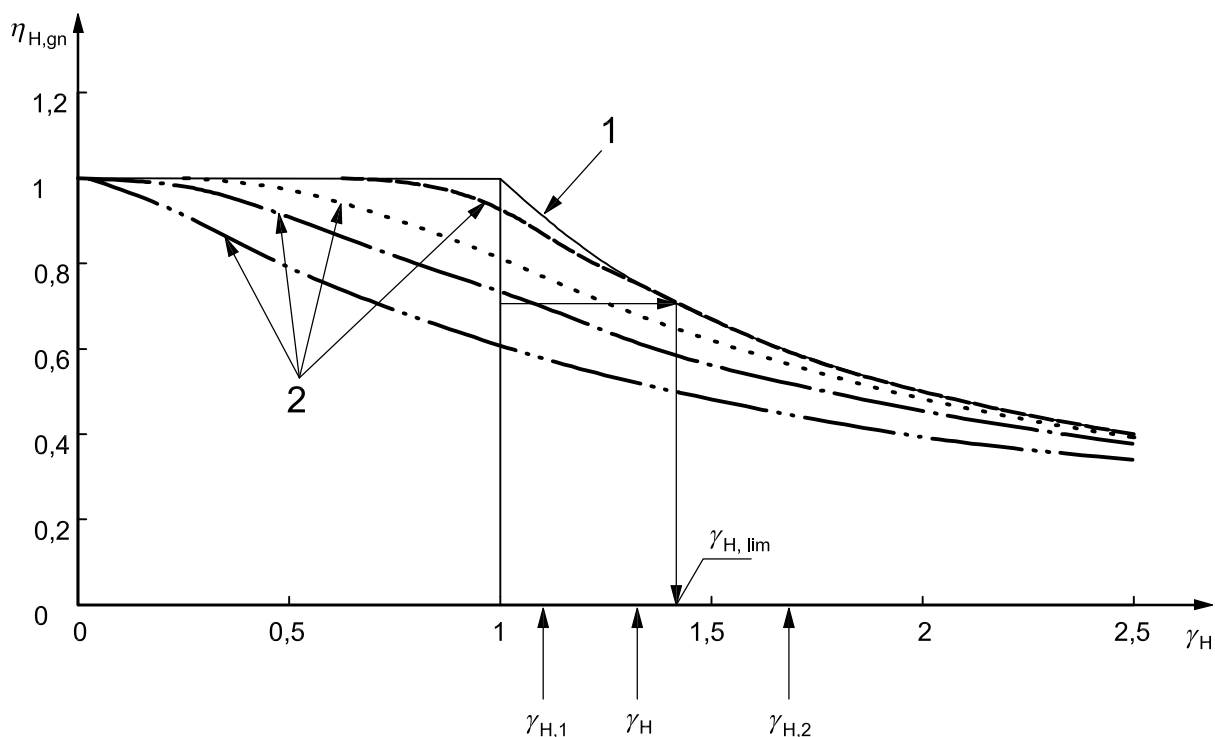

Key

- 1 ideal curve (high inertia)
- 2 real inertia, see for example Figure 5 (but not relevant here)

Figure 4 — Illustration of the procedure according to method b to determine the actual length of the heating season (monthly method)

And determine for each month:

- The value of γ_H at the beginning of the month. This value is simply calculated as the mean value of γ_H for the considered month and the previous month (previous month for January is December). The value of γ_H at the end of the month. This value is simply calculated as the mean value of γ_H for the considered month and the next month (next month for December is January). The lowest of the two values is called $\gamma_{H,1}$ the highest is called $\gamma_{H,2}$. Negative values of γ_H shall be replaced by the value from the nearest month with positive value of γ_H .
- If $\gamma_{H,2} < \gamma_{H,lim}$ the whole month is part of the heating period: $f_H = 1$.
- If $\gamma_{H,1} > \gamma_{H,lim}$ the whole month is outside the heating period: $f_H = 0$.
- Otherwise, a fraction of the month is part of the heating period:
 - If $\gamma_H > \gamma_{H,lim}$: $f_H = 0,5 (\gamma_{H,lim} - \gamma_{H,1}) / (\gamma_H - \gamma_{H,1})$;
 - If $\gamma_H \leq \gamma_{H,lim}$: $f_H = 0,5 + 0,5 (\gamma_{H,lim} - \gamma_H) / (\gamma_{H,2} - \gamma_H)$.

7.4.1.2 Cooling season

In the absence of a national method, the actual length of the cooling season to determine the number of hours of operation of certain season-length-dependent provisions (e.g. pumps, fans, central pre-cooling; see 14.3) can be determined as follows.

The actual length of the cooling season, L_C , expressed in the number of months, is calculated by using Equation (13):

$$L_C = \sum_{m=1}^{m=12} f_{C,m} \quad (13)$$

where $f_{C,m}$ is the fraction of the month m that is part of the cooling season.

Determine f_C for each month according to one of the following two methods:

- method a: simplified method, on the basis of the ratio between the energy need for cooling and heating.
- method b: on the basis of the monthly values for the heat-balance ratio for the cooling mode, γ_C , determined in accordance with 12.2.1.2.

Method a:

The fraction of the month that is part of the cooling season, is calculated by using Equation (14):

$$f_C = Q_{C,nd} / (Q_{H,nd} + Q_{C,nd}) \quad (14)$$

where

$Q_{H,nd}$ is the monthly energy need for heating, expressed in megajoules, determined in accordance with 7.2.1.1;

$Q_{C,nd}$ is the monthly energy need for cooling, expressed in megajoules, determined in accordance with 7.2.1.2.

Method b:

NOTE 1 The procedure is similar to the procedure for the heating mode, but with $1/\gamma_C$ instead of γ_H .

Determine $f_{C,m}$ for each month as follows.

Determine first the limit value of the dimensionless heat-balance ratio for the cooling mode $\gamma_{C,lim}$, by using Equation (15):

$$(1/\gamma_C)_{lim} = (a_C + 1) / a_C \quad (15)$$

where a_C is a dimensionless numerical parameter depending on the time constant of the building, determined in accordance with 12.2.1.2.

NOTE 2 The value for $(1/\gamma_C)_{lim}$ corresponds to the point at the *ideal* loss utilization curve with loss utilization factor equal to the *actual* loss utilization factor at $1/\gamma_C = 1$. A lower curve (less utilization, lower a_C) leads to a higher limit; for the ideal curve the limit is $(1/\gamma_C)_{lim} = 1$: the loss utilization factor = 1 and the monthly heat losses by transmission and ventilation heat transfer are just enough to compensate the monthly heat gains.

And determine for each month:

- the value of $1/\gamma_C$ at the beginning and end of the month, as the mean value of $1/\gamma_C$ for the considered month and the previous month and the mean value of $1/\gamma_C$ for the considered month and the next month (previous month for January is December; next month for December is January). The lowest of the two values is called $(1/\gamma_C)_1$, the highest is called $(1/\gamma_C)_2$. Negative values of $1/\gamma_C$ shall be replaced by the value from the nearest month with positive value of $1/\gamma_C$.
- If $(1/\gamma_C)_2 < (1/\gamma_C)_{lim}$ the whole month is part of the cooling period: $f_C = 1$.
- If $(1/\gamma_C)_1 > (1/\gamma_C)_{lim}$ the whole month is outside the cooling period: $f_C = 0$.
- Otherwise, a fraction of the month is part of the cooling period:
 - If $(1/\gamma_C) > (1/\gamma_C)_{lim}$: $f_C = 0,5 [(1/\gamma_C)_{lim} - (1/\gamma_C)_1] / [(1/\gamma_C) - (1/\gamma_C)_1]$;
 - If $(1/\gamma_C) \leq (1/\gamma_C)_{lim}$: $f_C = 0,5 + 0,5 [(1/\gamma_C)_{lim} - (1/\gamma_C)] / [(1/\gamma_C)_2 - (1/\gamma_C)]$.

7.4.2 Seasonal method

The actual length of the heating and cooling season depends on the heat-balance ratio and thermal inertia. These lengths are needed to know the number of operation hours of certain season-length-dependent provisions (e.g. pumps, fans).

A calculation method to determine the actual length of the heating and cooling season may be determined at national level. In the absence of a national method, the fixed length of the heating and cooling season (see Annex I.3) may be used as a conservative number.

7.4.3 Simple hourly method

The length of heating and cooling season is needed to know the number of hours of operation of certain systems with auxiliary energy use (e.g. pumps, fans).

The lengths of the heating and cooling seasons (number of days or hours) are determined by averaging the heating or cooling need over the previous four weeks. The start and end of the heating and cooling seasons is determined with a threshold value of 1 W/m² floor area.

The length of cooling season can be reduced by an extra (energy-consuming) provision such as mechanical or natural night-time ventilation or free cooling; consequently, for the operation period of such provision it is necessary to calculate the length of the cooling season without this provision or count the hours of operation of such a provision.

8 Heat transfer by transmission

8.1 Calculation procedure

The calculation procedure depends on the type of calculation method, but the assumptions (on environment conditions, user behaviour and controls) and the basic physical data shall be the same for each type of calculation method (seasonal, monthly, simple hourly and detailed simulation methods). See Table 4.

Table 4 — Calculation procedure for thermal transmission heat transfer for the different types of methods

Type of method	Total heat transfer by transmission	Transmission heat transfer coefficients	Input data and boundary conditions
Seasonal or monthly method	8.2	8.3	8.4
Simple hourly method	Not applicable	8.3	8.4
Detailed simulation method	Not applicable ^a	Not applicable ^a	8.4
^a But compliance with steady-state properties is to be demonstrated.			

8.2 Total heat transfer by transmission per building zone

For the monthly and seasonal method, the total heat transfer by transmission, Q_{tr} , expressed in megajoules, is calculated for each month or season and for each zone, z , as given by Equation (16):

$$\text{For heating: } Q_{tr} = H_{tr,adj}(\theta_{int,set,H} - \theta_e)t \quad (16)$$

$$\text{For cooling: } Q_{tr} = H_{tr,adj}(\theta_{int,set,C} - \theta_e)t$$

where (for each building zone, z , and for each calculation step)

$H_{tr,adj}$ is the overall heat transfer coefficient by transmission of the zone, adjusted for the indoor-outdoor temperature difference (if applicable), determined in accordance with 8.3, expressed in watts per kelvin,

$\theta_{int,set,H}$ is the set-point temperature of the building zone for heating, determined in accordance with Clause 13, expressed in degrees centigrade;

$\theta_{int,set,C}$ is the set-point temperature of the building zone for cooling, determined in accordance with Clause 13, expressed in degrees centigrade;

θ_e is the temperature of the external environment, determined in accordance with Annex F, expressed in degrees centigrade;

t is the duration of the calculation step, determined in accordance with Annex F, expressed in megaseconds.

NOTE The heat transfer or part of the heat transfer can have a negative sign during a certain period.

8.3 Transmission heat transfer coefficients

8.3.1 General

The value for the overall transmission heat transfer coefficient, $H_{tr,adj}$, expressed in watts per kelvin, shall be calculated in accordance with ISO 13789, using the following equation:

$$H_{tr,adj} = H_D + H_g + H_U + H_A \quad (17)$$

where

H_D is the direct heat transfer coefficient by transmission to the external environment, expressed in watts per kelvin;

H_g is the steady-state heat transfer coefficient by transmission to the ground, expressed in watts per kelvin;

H_U is the transmission heat transfer coefficient by transmission through unconditioned spaces, expressed in watts per kelvin;

H_A is the heat transfer coefficient by transmission to adjacent buildings, expressed in watts per kelvin.

In general, H_x , representing H_D , H_g , H_U , or H_A , consists of three terms (see ISO 13789):

$$H_x = b_{tr,x} [\sum_i A_i U_i + \sum_k l_k \Psi_k + \sum_j \chi_j] \quad (18)$$

where

A_i is the area of element i of the building envelope, in square metres;

U_i is the thermal transmittance of element i of the building envelope, expressed in watts per square metre kelvin;

l_k is the length of linear thermal bridge k , expressed in metres;

Ψ_k is the linear thermal transmittance of thermal bridge k , expressed in watts per metre kelvin;

χ_j is the point thermal transmittance of point thermal bridge j , expressed in watts per kelvin;

$b_{tr,x}$ is the adjustment factor, with value $b_{tr,x} \neq 1$ if the temperature at the other side of the construction element is not equal to the external environment, such as in the case of a partition to adjacent conditioned or unconditioned spaces or as in the case of a ground floor; the value shall be determined in accordance with 8.3.2;

NOTE The adjustment factor, b , adjusts the coefficient instead of the temperature difference.

and where the summation is done over all the building components separating the internal environment and the environment at the other side of the construction (external, ground, unconditioned space or adjacent conditioned space).

In case of more than one type of ground floor, or more than one adjacent unconditioned or conditioned space, the values for the transmission heat transfer coefficients are summated, using for each element the corresponding value for the adjustment factor, $b_{tr,x}$.

In the case of thermally coupled zones, calculated in accordance with 6.3.3.3, the heat transmission coefficient of the partition between the zones is calculated separately, as explained, for example, in 10.2.1 and 11.2.1.

In the application of ISO 13789, the specific procedures of 8.3.2 shall be followed.

8.3.2 Specific procedures

8.3.2.1 Heat transmission through windows and doors or curtain walls

8.3.2.1.1 General

The values for the heat transmission coefficient, $H_{tr,k}$, of windows and doors or curtain walls are determined in accordance with the relevant standard on thermal transmission of windows and doors or curtain walls as specified in Annex A.

For each window the frame area fraction shall be determined in accordance with ISO 10077-1.

As an alternative, it may be nationally decided to use a fixed frame area fraction for all windows in the building.

NOTE For instance, in the case of heating-dominated climates, use 0,20 or 0,30, whichever leads to the highest U -value of the window (see 8.3.1) or a fixed value of 0,30. For cooling-dominated climates use a fixed value of 0,20.

8.3.2.1.2 Simple hourly method

For the simple hourly method a distinction is needed between transmission through lightweight building elements (windows, doors, curtain walls, other glazed elements), and through heavyweight building elements.

8.3.2.2 Effect of nocturnal insulation

8.3.2.2.1 Seasonal or monthly method

When shutters are present, the values for the heat transmission coefficient, $H_{tr,k}$, of the window concerned within element k may be reduced by applying the following reduced thermal transmittance of window and shutter, $U_{w,corr}$, expressed in watts per square metre kelvin, as given by Equation (19):

$$U_{w,corr} = U_{w+shut} f_{shut} + U_w (1 - f_{shut}) \quad (19)$$

where

U_{w+shut} is the thermal transmittance of window and shutter together, expressed in watts per square metre kelvin;

f_{shut} is the dimensionless fraction of accumulated temperature difference for period with shutter closed;

U_w is the thermal transmittance of window without shutter, expressed in watts per square metre kelvin.

NOTE An example of the calculation of f_{shut} is given in Annex G.

8.3.2.2.2 Simple hourly method

For the simple hourly method the appropriate U -value is chosen on hourly basis.

ISO 13790:2008(E)

8.3.2.3 Heat transmission to the ground

The appropriate temperature difference compared to heat transmission to the external environment, due to the large inertia of the ground (annual cycle), is taken into account in ISO 13789 by an adjustment factor, $b_{tr,x}$, that adjusts the heat transfer coefficient instead of the temperature difference.

The value for the adjustment factor, $b_{tr,x}$, is different per month. This also applies to the simple hourly method.

Alternatively, it may be decided at national level to allow seasonal values for the adjustment factor, $b_{tr,x}$, which are different for the heating and cooling period.

NOTE 1 In this context ISO 13789 requires, as input, the value of the set-point for the internal temperature for heating, $\theta_{int,set,H}$, and for cooling, $\theta_{int,set,C}$, respectively.

NOTE 2 There is a monthly variation in the coefficient for heat transmission to the ground because it includes a correction for the periodic heat flow through the ground (annual cycle). See ISO 13370:2007, Clause A.7.

8.3.2.4 Heat transmission to adjacent unconditioned space

The reduced temperature difference compared to heat transmission to the external environment is taken into account in ISO 13789 by an adjustment factor, $b_{tr,x}$, that reduces the heat transfer coefficient instead of the temperature difference.

Default values for the adjustment factor, $b_{tr,x}$, may be defined at national level, depending on the type of building and/or application.

NOTE National default values can, for instance, be defined in the case of assessment of old existing buildings, if gathering the full required input would be too labour-intensive for the purpose, relative to the cost-effectiveness of gathering the input.

8.3.2.5 Heat transmission to adjacent sunspace (greenhouse)

For the heat transmission the same procedure in ISO 13789 is followed as for an adjacent unconditioned space.

However, if the simplified procedure given in E.2.4 is applied, the adjustment factor, $b_{tr,x}$, includes the combined effect of heat transmission and solar radiation, which is in line with the general procedure given in Annex A of ISO 13789:2007.

NOTE 1 Otherwise, the effect of solar radiation on the temperature of the attached sunspace is taken into account as part of the calculation of the solar heat gains (Clause 11; see also E.2.3)

NOTE 2 E.2.4 provides the conditions and specifications for the simplified procedures.

8.3.2.6 Heat transmission to adjacent buildings

The appropriate temperature difference compared to heat transmission to the external environment is taken into account in ISO 13789 by an adjustment factor, $b_{tr,x}$, that adjusts the heat transfer coefficient instead of the temperature difference.

NOTE 1 See ISO 13789 for inclusion of this element. In this context, ISO 13789 requires, as input, the value of the set-point for the internal temperature for heating, $\theta_{int,set,H}$, and for cooling, $\theta_{int,set,C}$.

It may be determined at national level if, depending on the purpose of the calculation, this element in the heat transmission may or shall be ignored.

NOTE 2 For instance, because of legal restrictions forbidding the characteristics of other buildings (which can be subject to change in the course of time) to have an influence on whether the legally required minimum energy performance level is maintained.

8.3.2.7 Multi-zone calculation with uncoupled versus coupled zones

For multi-zone calculation with thermally uncoupled zones, heat transmission to other conditioned zones is not applicable.

For multi-zone calculation with thermally coupled zones, heat transmission to adjacent conditioned zone(s) is calculated by using for the temperature, $\theta_{e,k}$, the value for the temperature of the adjacent zone k , determined in accordance with Annex B.

NOTE For this situation the adapted temperature difference compared to heat transmission to the external environment is not taken into account by a reduction factor b , but by using directly an adapted temperature difference.

8.3.2.8 Thermal bridges

The heat transfer by transmission includes area-related heat loss by transmission as well as linear and point thermal bridges. The heat transmission by thermal bridges is taken into account in ISO 13789 as part of H_{tr} .

8.3.2.9 Heating and cooling mode

In the case of different properties for the heating and cooling mode, separate H_{tr} values shall be used for each mode. This is, for instance, applicable in the case of windows with movable shutters or different summer and winter modes, ground floor heat transfer and heat transfer to an attached sunspace (greenhouse).

8.3.2.10 Special elements

See 8.4.2 for specific details for special elements.

8.4 Input data and boundary conditions

8.4.1 General principles

8.4.1.1 Seasonal, monthly and simple hourly methods

Except for specific cases (see below), the physical characteristics that are required as input are already obtained as part of the procedure in 8.3.

8.4.1.2 Detailed simulation methods

For detailed dynamic simulations methods, the input data on heat transmission elements are in general more detailed than for the seasonal, monthly or simple hourly methods. However, the basic physical data and the assumptions (on relevant environment conditions, user behaviour and controls) shall be in accordance with 8.3. Consequently, it shall be verified that the monthly values of the overall transmission heat transfer used in the dynamic simulation method are the same as the overall transmission heat transfer for the other methods which are determined on the basis of 8.3.

In this respect, specific attention is required for:

- thermal bridges: the same thermal bridge effects as prescribed for the other methods in 8.3 shall be taken into account;
- heat transmission coefficient to the ground: the procedure given in ISO 13370:2007, Annex D, shall be applied to calculate the dynamic heat transfer by transmission through the ground floor. This calculation involves a virtual layer below the floor construction and a (monthly varying) temperature below that virtual layer as boundary condition.

8.4.1.3 All methods

In the case of old existing buildings, if gathering the full required input would be too labour-intensive for the purpose, relative to the cost-effectiveness of gathering the input, simplified methods or input may be used. Specification of the conditions for allowing this simple method or input may be made at national level, depending on the purpose of the calculation. In that case the user shall report which method or input has been used and from which source. Examples are given in Annex G.

8.4.2 Special elements

Special methods are needed to calculate the influence of special elements:

- **Ventilated solar walls:** see Annex E.
- **Other ventilated envelope elements:** see Annex E.
- **Internal heat sources with a heat flow that is a predominant function of the internal temperature:** If a heat source of a potentially significant magnitude is a predominant function of the internal temperature, e.g. a source temperature that is close to the internal temperature (such as a water tank maintained at a specified temperature), the amount of heat transferred is strongly dependent on the temperature difference between source and internal environment. In that case, the source shall not be added to the internal heat gains, but the heat transfer shall be added to the heat transfer by transmission, determined in this clause. The temperature, $\theta_{e,k}$, is the value for the temperature of the source and the value for the heat transmission coefficient, $H_{tr,k}$, of the element is the product of the exposed source area, in square metres, and the heat transfer coefficient in watts per metres squared kelvin.

9 Heat transfer by ventilation

9.1 Calculation procedure

The calculation procedure depends on the type of calculation method, but the assumptions (on environment conditions, user behaviour and controls) and the basic physical data shall be the same for each type of calculation method (seasonal, monthly, simple hourly and detailed simulation methods). See Table 5.

Table 5 — Calculation procedure for ventilation heat transfer for the different types of methods

Type of method	Total heat transfer by ventilation	Ventilation heat transfer coefficients	Input data and boundary conditions
Seasonal or monthly method	9.2	9.3	9.4
Simple hourly method	Not applicable	9.3	9.4
Detailed simulation method	Not applicable ^a	Not applicable ^a	9.4

^a But compliance with steady-state properties is to be demonstrated.

9.2 Total heat transfer by ventilation per building zone — Seasonal or monthly method

For the monthly and seasonal method, the total heat transfer by ventilation, Q_{ve} , expressed in megajoules, is calculated for each month or season and for each zone, z , as given by Equation (20):

$$\text{For heating: } Q_{ve} = H_{ve,adj}(\theta_{int,set,H,z} - \theta_e)t \quad (20)$$

$$\text{For cooling: } Q_{ve} = H_{ve,adj}(\theta_{int,set,C,z} - \theta_e)t$$

where (for each building zone, z , and for each calculation step)

- $H_{ve,adj}$ is the overall heat transfer coefficient by ventilation, adjusted for the indoor-outdoor temperature difference (if applicable), determined in accordance with 9.3, expressed in watts per kelvin;
- $\theta_{int,H,set}$ is the set-point temperature of the building zone for heating, determined in accordance with Clause 13, expressed in degrees centigrade;
- $\theta_{int,C,set}$ is the set-point temperature of the building zone for cooling, determined in accordance with Clause 13, expressed in degrees centigrade;
- θ_e is the temperature of the external environment, determined in accordance with Annex F, expressed in degrees centigrade;
- t is the duration of the calculation step, determined in accordance with Annex F, expressed in megaseconds.

NOTE The heat transfer or part of the heat transfer can have a negative sign during a certain period, in which case heat is added to the building (zone).

9.3 Ventilation heat transfer coefficients

9.3.1 General

The value for the overall ventilation heat transfer coefficient, $H_{ve,adj}$, expressed in watts per kelvin, is calculated as given by Equation (21):

$$H_{ve,adj} = \rho_a c_a \left(\sum_k b_{ve,k} q_{ve,k,mn} \right) \quad (21)$$

where

- $\rho_a c_a$ is the heat capacity of air per volume, expressed in joules per cubic metres per kelvin = 1 200 J/(m³·K);
- $q_{ve,k,mn}$ is the time-average airflow rate of air flow element k , expressed in cubic metres per second;
- $b_{ve,k}$ is the temperature adjustment factor for air flow element k , with value $b_{ve,k} \neq 1$ if the supply temperature, $\theta_{sup,k}$, is not equal to the temperature of the external environment, such as in the case of pre-heating, pre-cooling or heat recovery; the value shall be determined in accordance with 9.3.3;

NOTE 1 The temperature adjustment factor, b , adjusts the coefficient instead of the temperature difference.

- k represents each of the relevant air flow elements, such as air infiltration, natural ventilation, mechanical ventilation and/or extra ventilation for night-time cooling.

The time-average airflow rate of air flow element k , $q_{ve,k,mn}$, expressed in cubic metres per second, is calculated by using Equation (22):

$$q_{ve,k,mn} = f_{ve,t,k} q_{ve,k} \quad (22)$$

where

- $q_{ve,k}$ is the airflow rate of air flow element k , determined in accordance with the relevant standard as specified in Annex A, expressed in cubic metres per second;
- $f_{ve,t,k}$ is the time fraction of operation of the air flow element k , calculated as the fraction of the number of hours per day (full time: $f_{ve,t,k} = 1$), determined from the same source as $q_{ve,k}$.

ISO 13790:2008(E)

NOTE 2 For monthly or seasonal methods: in the case of intermittent heating or cooling where, following 13.2.2, the effect of intermittency is taken into account by a reduction factor on the energy need for heating or cooling, the time fraction is calculated assuming continuous heating or cooling, thus disregarding days with reduced heating or cooling set-point or switch-off.

In the application of the relevant standards specified in Annex A, the specific procedures of 9.3.3 shall be followed.

9.3.2 Simple hourly method

If the zone receives air flows from different sources (for example from external environment and from the ventilation system) and H_{ve} is, at each hour, calculated in accordance with Equation (21), the supply temperature adjustment is already taken into account in H_{ve} in which case $H_{ve} = H_{ve,adj}$ and $\theta_{sup} = \theta_e$.

9.3.3 Specific procedures

9.3.3.1 Heating and cooling mode

In the case of different properties for the heating and cooling mode, separate input values shall be used. This is applicable for instance in the case of different summer and winter ventilation rates, heat recovery units and heat transfer to an attached sunspace (greenhouse).

9.3.3.2 Climate data

The values obtained from the relevant standards on the amount of air flow and on ventilation systems in accordance with Annex A shall be based upon the same climate as used for the calculation in this International Standard and specified in Annex F.

9.3.3.3 Ventilation including air infiltration from the exterior

The supply temperature, $\theta_{sup,k}$, is the value of the temperature of the external environment, θ_e , in accordance with Annex F. Consequently, the temperature adjustment factor, $b_{ve,k}$, for air flow from the exterior environment is equal to:

$$b_{ve,k} = 1 \quad (23)$$

9.3.3.4 Ventilation including air infiltration from adjacent unconditioned space

The supply temperature, $\theta_{sup,k}$, is the value of the temperature of the external environment, θ_e , in accordance with Annex F. Consequently, the temperature adjustment factor, $b_{ve,k}$, for air flow from adjacent unconditioned spaces is equal to:

$$b_{ve,k} = 1 \quad (23)$$

NOTE This is a simplification.

9.3.3.5 Ventilation from adjacent sunspace (greenhouse)

The supply temperature, $\theta_{sup,k}$, is the value of the temperature of the external environment, θ_e , in accordance with Annex F. Consequently, the temperature adjustment factor, $b_{ve,k}$, for air flow from adjacent unconditioned spaces is equal to:

$$b_{ve,k} = 1 \quad (23)$$

If it can be demonstrated that during the heating season the air flow element enters the conditioned zone via the adjacent sunspace, it is permissible to use for the temperature adjustment factor:

$$b_{ve,k} = b_{tr,x} \quad (24)$$

where $b_{tr,x}$ is the temperature adjustment factor applied in 8.3 for heat transmission to the adjacent sunspace.

The temperature adjustment factor can be converted to a number expressing the efficiency of heat recovery via the sunspace, $\eta_{ve,k}$, using the following equation:

$$\eta_{ve,k} = (1 - b_{ve,k}) \quad (25)$$

This can be useful for instance in case of combination with a heat recovery unit (see 9.3.3.8)

NOTE 1 If the simplified method in E.2.4 is used, $b_{tr,x}$ includes the positive effect of solar radiation on the temperature of the attached sunspace. If the full method in E.2 is used, it does not.

NOTE 2 Usually the value for $b_{ve,k}$ is different for heating and cooling seasons, or monthly.

9.3.3.6 Ventilation including air infiltration from adjacent buildings

If applicable, the supply temperature, $\theta_{sup,k}$, is the value of the temperature of the adjacent building that may be determined at national level, depending on the application.

Consequently, the temperature adjustment factor, $b_{ve,k}$, for air flow from adjacent buildings is equal to:

$$b_{ve,k} = \frac{(\theta_{int,set} - \theta_{sup,k})}{(\theta_{int,set} - \theta_e)} \quad (26)$$

where

$\theta_{int,set}$ is the set-point temperature of the building zone for heating or cooling, determined in accordance with Clause 13, expressed in degrees centigrade;

$\theta_{sup,k}$ is the supply temperature, equal to the internal temperature of the adjacent building, expressed in degrees centigrade;

θ_e is the temperature of the external environment, determined in accordance with Annex F, expressed in degrees centigrade.

It may be determined at national level if, depending on the purpose of the calculation, this element in the ventilation heat transfer may or shall be ignored. In that case the temperature adjustment factor $b_{ve,k} = 0$. If not ignored, the value of the internal temperature of the adjacent building may be determined at national level.

NOTE Normally, this term is probably (assumed to be) zero. But it can, for instance, be relevant in the case of comparison with measured energy where infiltration or ventilation from adjacent buildings plays a role.

9.3.3.7 Multi-zone calculation with uncoupled versus coupled zones

For multi-zone calculation with thermally uncoupled zones, heat transfer by infiltration or ventilation from other conditioned zones is not applicable.

For multi-zone calculation with thermally coupled zones: the supply temperature, $\theta_{sup,k}$, of the ventilation, including air infiltration from adjacent conditioned zone(s), is the value of the temperature of the adjacent zone, calculated in accordance with Annex B.

9.3.3.8 Heat recovery unit

A heat recovery unit, if present, is usually an important element in the heat balance of the building zone, strongly influencing the utilization of heat gains and free heating or cooling potential. For that reason the effect of the use of heat recovery units shall be taken into account in the calculation of the energy needs for heating and cooling and cannot be dealt with via a separately determined correction factor.

NOTE See 7.3 on the optional extra (informative) calculation to isolate the energy needs for heating and cooling without heat recovery.

ISO 13790:2008(E)

The temperature adjustment factor, $b_{ve,k}$, for air flow from a heat recovery unit is equal to:

$$b_{ve,k} = (1 - f_{ve,frac,k} \times \eta_{hru}) \quad (27)$$

where

η_{hru} is the efficiency of the heat recovery unit, obtained from the relevant standard on ventilation systems as specified in Annex A, taking into account representative conditions which may be determined at national level;

$f_{ve,frac,k}$ is the fraction of the considered air flow element k that goes through the heat recovery unit.

If the relevant standard on ventilation systems specified in Annex A provides the supply temperature $\theta_{sup,k}$, instead of the efficiency of the heat recovery unit, the efficiency, η_{hru} , is obtained by the following conversion:

$$\eta_{hru} = \frac{(\theta_{sup,k} - \theta_e)}{(\theta_{int,set} - \theta_e)} \quad (28)$$

where

$\theta_{sup,k}$ is the supply temperature from the heat recovery unit, expressed in degrees centigrade, obtained from the relevant standard on ventilation systems specified in Annex A, taking into account representative conditions which may be determined at national level;

$\theta_{int,set}$ is the set-point temperature of the building zone for heating or cooling, determined in accordance with Clause 13, expressed in degrees centigrade;

$\theta_{sup,k}$ is the supply temperature, equal to the internal temperature of the adjacent building, expressed in degrees centigrade.

In the application of the relevant standards specified in Annex A, the following shall be taken into account.

— General

If the heat recovery unit is switched off or if the heat exchanger is bypassed to prevent the risk of freezing of the unit, this shall be properly accounted for in the supplied data. If applicable, the data on additional sources of ventilation air shall be provided, such as infiltration and natural ventilation, to avoid an overestimation of the performance of the heat recovery unit and/or underestimation of the total amount of ventilation flow rate to the building or building zone.

NOTE Usually the effect will be different for the heating and cooling season.

— Climate data

The values obtained from the relevant standards on the efficiency of the heat recovery unit and the values for the supply temperature, $\theta_{sup,k}$, and for the additional energy (for fan power, defrost, etc.) shall be based upon the same climate as used for the calculation in this International Standard, as specified in Annex F.

— Auxiliary energy use

Additional energy, e.g. for defrosting and energy needed to power the fan, shall be added separately, see 14.3.3.

— **Combination with central pre-heating or pre-cooling**

If, in series with the heat recovery unit, central pre-heating or pre-cooling is present, the supply temperature to the building or building zone is the temperature after pre-heating or pre-cooling. Consequently, the temperature adjustment factor, $b_{ve,k}$, for air flow from central pre-heating or pre-cooling is determined according to Equation (30).

— **Effect of control**

If the heat recovery unit has a heat exchanger control without overheating control function (either dynamic, or on a seasonal basis), this shall be properly accounted for in the value of the efficiency of the heat recovery unit, η_{hru} .

— **Series of two heat recovery provisions**

In the case of two provisions for heat recovery in series, the combined efficiency of heat recovery, $\eta_{ve,k}$, is given by Equation (29):

$$\eta_{ve,k} = \eta_{ve,k1} + \eta_{ve,k2} - (\eta_{ve,k1} \eta_{ve,k2}) \quad (29)$$

where

$\eta_{ve,k1}$ is the efficiency of heat recovery by provision 1;

$\eta_{ve,k2}$ is the efficiency of heat recovery by provision 2.

EXAMPLE Used for a combination of heat recovery unit and solar collector or sunspace, only for the portion of air flow that passes through both provisions.

9.3.3.9 Ventilation from a mechanical ventilation system with central pre-heating or pre-cooling

The energy use by central pre-heating or pre-cooling may be calculated separately from the energy use for the building or building zone, if the supply temperature is not controlled by the internal temperature of the building or building zone. In that case, the procedure described as method A shall be used.

Alternatively, it may be decided at national level, depending on the application, to use as supply temperature the external air temperature in accordance with Annex F. See method B.

NOTE 1 In the latter case it is implicitly assumed that the heating or cooling system servicing the building zone also services the energy need for pre-heating or pre-cooling.

If the supply temperature is controlled by the internal temperature of the building or building zone, for instance in the case of an air heating or cooling system, the energy need of the central pre-heating or pre-cooling shall be taken into account as an integral part of the calculation of the energy need of the building or building zone. In this case the procedure described in method B shall be used.

NOTE 2 If the supply temperature from the central air-handling unit depends on the internal temperature, it cannot be taken as input for the energy balance in the building or building zone, because it depends on the energy balance. It is the output of the energy balance instead of the input.

Method A: separate calculation of central pre-heating or pre-cooling

The ventilation heat transfer coefficient, $H_{ve,k}$, shall be based on the supply temperature, $\theta_{sup,k}$, of the air as it leaves the central air handling unit and enters the building zone.

Consequently, the temperature adjustment factor, $b_{ve,k}$, for air flow after central pre-heating or pre-cooling is equal to:

$$b_{ve,k} = \frac{(\theta_{int,set} - \theta_{sup,k})}{(\theta_{int,set} - \theta_e)} \quad (30)$$

where

- $\theta_{int, set}$ is the set-point temperature of the building zone for heating or cooling, determined in accordance with Clause 13, expressed in degrees centigrade;
- $\theta_{sup,k}$ is the supply temperature of the air as it leaves the central air handling unit and enters the building zone, determined in accordance with the relevant standard on ventilation systems as specified in Annex A, expressed in degrees centigrade;
- θ_e is the temperature of the external environment, determined in accordance with Annex F, expressed in degrees centigrade.

The energy need for pre-heating or pre-cooling is calculated separately (see 9.3.3.12).

Method B: central pre-heating or pre-cooling included in the calculation of energy need for heating or cooling

The ventilation heat transfer coefficient, $H_{ve,k}$, shall be based on the external temperature: $\theta_{sup,k} = \theta_e$. Consequently: $b_{ve,k} = 1$ (see 9.3.3.3).

9.3.3.10 Free cooling and night-time ventilation during cooling mode — Definitions and rules

NOTE Definitions and rules are copied from EN 15232.

Night cooling: the flow rate of external air is set to its maximum during the unoccupied period, provided

- a) the internal temperature is above the set-point for the comfort period,
- b) the difference between the internal temperature and the external temperature is above a given limit.

Free cooling: the flow rates of external air and recirculation air are modulated during all periods of time to minimize the amount of mechanical cooling. Calculation is performed on the basis of temperatures.

H,x-directed control: the flow rates of external air and recirculation air are modulated during all periods of time to minimize the amount of mechanical cooling. Calculations are performed on the basis of temperatures and humidity (enthalpy).

In the case of ventilation for free cooling and/or night-time ventilation during the cooling period, an extra term, $q_{ve,extra}$, for the air flow rate into the conditioned space may be taken into account, as specified in 9.4.3.

9.3.3.11 Special elements

See 9.4.4 for specific details for special elements.

9.3.3.12 Energy need for central pre-heating or pre-cooling

The energy need for pre-heating or pre-cooling of ventilation air, $Q_{V,pre-heat}$ or $Q_{V,pre-cool}$, expressed in megajoules, is calculated using the temperature difference between the external temperature and the supply temperature after the central pre-heating or pre-cooling, as given by Equations (31) and (32):

$$\text{For pre-heating: } Q_{V,pre-heat} = \rho_a c_a f_{ve,t,k} q_{ve,k} (\theta_{sup,k} - \theta_e) t \quad (31)$$

$$\text{For pre-cooling: } Q_{V,pre-cool} = \rho_a c_a f_{ve,t,k} q_{ve,k} (\theta_e - \theta_{sup,k}) t \quad (32)$$

For a monthly or seasonal method: in the case of intermittent heating or cooling where, following 13.2.2, the effect of intermittency is taken into account by a reduction factor on the energy need for heating or cooling, the time fraction shall be calculated assuming continuous heating or cooling, thus disregarding days with reduced heating or cooling set-point or switch-off.

where (for each building zone, z , and for each calculation step)

- $f_{ve,t,k}$ is the time fraction of operation, calculated as the fraction of the number of hours per day (full time: $f_t = 1$), determined in accordance with 9.3.1;
- $q_{ve,k}$ is the air flow rate by ventilation of air of flow element k , which is pre-heated or pre-cooled, entering the zone with supply temperature, $\theta_{sup,k}$, in accordance with the relevant standard as specified in Annex A, expressed in cubic metres per second;
- θ_e is the external air temperature, determined in accordance with Annex F, expressed in degrees centigrade;
- $\theta_{sup,k}$ is the supply temperature of the air flow element k entering the building zone by ventilation after pre-heating or pre-cooling, determined in accordance with 9.3.1, expressed in degrees centigrade;
- t is the duration of the calculation step, determined in accordance with Annex F, expressed in megaseconds;
- $\rho_a c_a$ is the heat capacity of air per volume, expressed in joules per cubic metres per kelvin = 1 200 J/(m³·K).

If pre-heating or pre-cooling is present in addition to heat recovery, the latter is taken into account by replacing the external temperature, θ_e , by the supply temperature from the heat recovery unit as obtained from the relevant standard on ventilation systems specified in Annex A. In that case, the temperature difference which is to be used in Equation (31) or (32) is the difference between the supply temperature from the heat recovery unit and the supply temperature after the central pre-heating or pre-cooling.

9.4 Input data and boundary conditions

9.4.1 General principles

9.4.1.1 Seasonal, monthly and simple hourly methods

Except for specific cases (see below), the physical characteristics that are required as input are already obtained as part of the procedure in 9.3.

9.4.1.2 Detailed simulation methods

For detailed dynamic simulations methods, the input data on heat transfer by infiltration and ventilation are sometimes more detailed than for the seasonal, monthly or simple hourly methods. However, the basic physical data and the assumptions (on relevant environment conditions, user behaviour and controls) shall be in accordance with 9.3. Consequently, it shall be verified that the monthly values of the overall ventilation heat transfer used in the dynamic simulation method are the same as the overall ventilation heat transfer for the other methods which are determined on the basis of 9.3.

9.4.1.3 All methods

In the case of old existing buildings, if gathering the full required input would be too labour-intensive for the purpose, relative to the cost-effectiveness of gathering the input, simplified methods or values for the air flow rate by infiltration and ventilation and default values for the supply temperature and time fraction of operation may be defined at national level. Specification of the conditions for allowing this simple method or input may be made at national level, depending on the purpose of the calculation. In that case the user shall report which method or input has been used and from which source. Examples are given in Annex G.

9.4.2 Hourly patterns

It may be decided at national level whether (for simple hourly method) and how (for all methods) a given hourly schedule is converted to a (weighted) mean time fraction of operation or whether the input data are differentiated over the day (different per hour) and/or over the week (different schedule per day).

9.4.3 Free cooling and night-time ventilation during cooling mode — Monthly and seasonal methods

For a monthly and seasonal method, during the cooling mode period, the extra volumetric flow rate, $q_{ve,extra,mn}$, into the conditioned space for free cooling and/or for night-time ventilation, expressed in cubic metres per second, is calculated as given by Equation (33):

$$q_{ve,extra,mn} = c_{ve,eff,extra} f_{ve,t,extra} q_{ve,extra} \quad (33)$$

In the case of intermittent cooling where, following 13.2.2, the effect of intermittency is taken into account by a reduction factor on the energy need for cooling, the time fraction shall be calculated assuming continuous cooling, thus disregarding days with reduced cooling set-point or switch-off.

where

$c_{ve,eff,extra}$ is an adjustment factor for dynamic (inertia) effects and effectiveness; unless otherwise specified at national level the value is $c_{ve,eff,extra} = 1,0$;

$f_{ve,t,extra}$ is the time fraction of operation of the free or night-time ventilation per day, calculated as the fraction of the number of hours per day of operation (full time: $f_{ve,t,extra} = 1$);

$q_{ve,extra}$ is the extra air flow rate into the conditioned space due to free cooling or night-time ventilation, expressed in cubic metres per second, with given time fraction of operation.

For the monthly and seasonal methods, the value for the associated temperature adjustment factor, $b_{ve,extra}$, can be used to adjust for the temperature difference during time of operation compared to a 24 h temperature difference. The value is $b_{ve,extra} = 1,0$, unless otherwise specified at national level.

Examples of values related to the extra air flow rate for free cooling or night-time ventilation are given in Annex G.

9.4.4 Special elements

Special methods are needed to calculate the influence of special elements:

- **Ventilated solar walls:** see Annex E;
- **Other ventilated envelope elements:** see Annex E;
- **Heat pump using ventilation exhaust air as source:** if the air flow rate needed for proper functioning of the heat pump in its intended application (e.g. to heat tap water) is higher than the air flow rate which would have been used as input for the calculation, the higher value shall be used in the calculation of the heat transfer by ventilation.

10 Internal heat gains

10.1 Calculation procedure

Internal heat gains, heat gains from internal heat sources, including negative heat gains (dissipated heat from internal environment to cold sources or “sinks”), consist of any heat generated in the conditioned space by internal sources other than the energy intentionally utilized for space heating, space cooling or hot water preparation.

The internal heat gains include:

- metabolic heat from occupants and dissipated heat from appliances;
- heat dissipated from lighting devices;
- heat dissipated from, or absorbed by, hot and mains water and sewage systems;
- heat dissipated from, or absorbed by, heating, cooling and ventilation systems;
- heat from or to processes and goods.

In this International Standard, if not directly taken into account as a reduction to the system losses, the recoverable system thermal losses are calculated as part of the internal heat gains. It may be decided at national level to report the recoverable system thermal losses separately from the other internal heat gains. See 3.4.

The calculation procedure depends on the type of calculation method, but the assumptions (on environment conditions, user behaviour and controls) and the input data shall be the same for each type of calculation method (seasonal, monthly, simple hourly and detailed simulation methods). See Table 6.

Table 6 — Calculation procedure for internal heat gains for the different types of methods

Type of method	Overall internal heat gains	Internal heat gain elements	Input data and boundary conditions
Seasonal or monthly method	10.2	10.3	10.4
Simple hourly method	10.2	10.3	10.4
Detailed simulation method	Not applicable	10.3	10.4

10.2 Overall internal heat gains

10.2.1 Monthly and seasonal method

For the monthly and seasonal method, the heat gains from internal heat sources in the considered building zone for the considered month or season, Q_{int} , expressed in megajoules, are calculated as given by Equation (34):

$$Q_{\text{int}} = \left(\sum_k \Phi_{\text{int,mn},k} \right) t + \left[\sum_l (1 - b_{\text{tr},l}) \Phi_{\text{int,mn},u,l} \right] t \quad (34)$$

where

$b_{\text{tr},l}$ is the reduction factor for the adjacent unconditioned space with internal heat source l , defined in ISO 13789;

- $\Phi_{\text{int,mn},k}$ is the time-average heat flow rate from internal heat source k , determined in accordance with 10.3, expressed in watts;
- $\Phi_{\text{int,mn},u,l}$ is the time-average heat flow rate from internal heat source l in the adjacent unconditioned space, determined in accordance with 10.3, expressed in watts;
- t is the length of the considered month or season, in accordance with Annex F, expressed in megaseconds.

An adjacent unconditioned space is an unconditioned space outside the boundaries of the zones for the calculation of the energy needs for heating and cooling. In the case of an unconditioned space adjacent to more than one conditioned zone, the value of the heat flow rate by internal heat source l in the unconditioned space, $\Phi_{i,\text{mean},u,l}$, shall be divided between the conditioned zones, weighted according to the floor areas per conditioned zone which are determined in 6.4.

In the case of a sunspace, Equation (34) applies if the detailed method in E.2 is applied. In the case of the simplified method, where internal and solar gains in the sunspace are already included in an adjusted value for b , the sunspace shall be ignored in Equation (34).

10.2.2 Simple hourly method

For the simple hourly method, the sum of the heat flow rates from internal heat sources in the considered building zone, Φ_{int} , expressed in watts, is calculated for each hour as given by Equation (35):

$$\Phi_{\text{int}} = \sum_k \Phi_{\text{int},k} + \sum_l (1 - b_{\text{tr},l}) \Phi_{\text{int},u,l} \quad (35)$$

The hourly values are usually given as daily or weekly patterns.

Alternatively, it may be decided nationally to calculate the heat flow rate from internal heat sources in the considered building zone as the time average over a given period as given by Equation (36):

$$\Phi_{\text{int}} = \sum_k \Phi_{\text{int,mn},k} + \sum_l (1 - b_{\text{tr},l}) \Phi_{\text{int,mn},u,l} \quad (36)$$

where

- $b_{\text{tr},l}$ is the adjustment factor for the adjacent unconditioned space with internal heat source l , defined in ISO 13789;
- $\Phi_{\text{int},k}$ is the hourly heat flow rate from internal heat source k , determined in accordance with 10.3, expressed in watts;
- $\Phi_{\text{int},u,l}$ is the hourly heat flow rate from internal heat source l in the adjacent unconditioned space, determined in accordance with 10.3, expressed in watts;
- $\Phi_{\text{int,mn},k}$ is the time-average heat flow rate from internal heat source k , determined in accordance with 10.3, expressed in watts;
- $\Phi_{\text{int,mn},u,l}$ is the time-average heat flow rate from internal heat source l in the adjacent unconditioned space, determined in accordance with 10.3, expressed in watts.

NOTE In practice, due to lack of reliable input data, the use of more detailed (including hourly) data does not necessarily lead to higher accuracy.

10.3 Internal heat gain elements — All methods

The heat gains from the following internal heat sources k in a specific building zone or sources l in an unconditioned space shall be taken into account.

- The internal heat flow rate from occupants, $\Phi_{\text{int,Oc}}$, determined in accordance with 10.4.2.
- The internal heat flow rate from appliances, $\Phi_{\text{int,A}}$, determined in accordance with 10.4.2.
- The internal heat flow rate from lighting, $\Phi_{\text{int,L}}$, determined in accordance with 10.4.3.
- The internal heat flow rate from hot and mains water and sewage, $\Phi_{\text{int,WA}}$, determined in accordance with 10.4.4.
- The internal heat flow rate from heating, cooling and ventilation systems, $\Phi_{\text{int,HVAC}}$, determined in accordance with 10.4.5.
- The internal heat flow rate from processes and goods, $\Phi_{\text{int,Proc}}$, determined in accordance with 10.4.6.

The principles for the calculation are:

- part of the heat dissipated in a system may be recovered either in the building or in the system itself, or in another system; this International Standard considers only the heat recoverable in the building;
- for reasons of simplification, it may be decided at national level to ignore in the calculation of the building energy needs, minor amounts of heat dissipated in a system that are actually recoverable in the building, and instead deal with these in the calculation of the performance of the system by adequate adjustment factors.
- a cold source, removing heat from the building (zone), shall be treated as a source, with a negative value;
- if a heat source of a potentially significant magnitude has a heat flow that is a predominant function of the temperature difference between source and internal environment, the heat from this source shall not be added to the internal heat gains, but the heat transfer shall be added to the heat transfer by transmission, determined in Clause 8.

NOTE For instance, a source at a constant temperature of 25 °C will *supply* a large amount of heat to the space when the space is at 16 °C; it will supply no heat at all when the space itself is at 25 °C and it will *extract* heat when the building zone is at a higher temperature.

10.4 Input data and boundary conditions

10.4.1 General

In the absence of national values, the values from Annex G may be used.

NOTE 1 Annex G provides examples of national input data: tables with typical occupancy patterns and associated values for the various internal heat sources.

In the case of old existing buildings, if gathering the full required input would be too labour-intensive for the purpose, relative to the cost-effectiveness of gathering the input, a simplified procedure may be defined at national level. Specification of the conditions for allowing this simplified procedure may be made at national level, depending on the purpose of the calculation. In that case the user shall report which method has been used and from which source.

NOTE 2 For example, it might be decided at national level to ignore in that case the heat flow rate resulting from internal heat sources in unconditioned spaces (e.g. except sunspaces).

10.4.2 Metabolic heat from occupants and dissipated heat from appliances

Hourly and weekly schedules of heat flow rate for metabolic heat from occupants, $\Phi_{\text{int,Oc}}$, and dissipated heat from appliances, $\Phi_{\text{int,A}}$, shall be determined on a national basis, as a function of building use, (optionally) occupancy class and purpose of the calculation.

For detailed simulation methods the thermal radiative and convective portions are each 50 %, unless otherwise stated.

10.4.3 Dissipated heat from lighting devices

The value for the internal heat flow rate from lighting, $\Phi_{\text{int,L}}$, is the sum of the following.

- The value for the internal heat flow rate from the luminaires, calculated as a fraction of the energy use of lighting systems calculated in accordance with the relevant standard on lighting systems as specified in Annex A. A fraction less than 1 is allowed in the case of heat being directly removed by exhaust ventilation via the luminaires, in accordance with a procedure defined at national level. If (part) of the exhaust air is recirculated, this heat shall be accounted for as a heat source in the ventilation system.
- The value for the internal heat flow rate from other lighting elements that are not covered in the previous category, such as decorative lighting, removable lighting, special-task lighting, building-grounds lighting, process-related lighting. For these other lighting elements, values may be specified on a national basis, depending on building use and purpose of the calculation.

For detailed simulation methods the thermal radiative and convective portions are each 50 %, unless otherwise stated.

10.4.4 Heat dissipated from, or absorbed by, hot and mains water and sewage systems

10.4.4.1 General

The internal heat flow rate due to recoverable losses from hot and mains water and sewage systems, $\Phi_{\text{int,WA}}$, expressed in watts, is the sum of three terms as given by Equations (37) and (38):

$$\Phi_{\text{int,WA}} = \Phi_{\text{int,W,circ}} + \Phi_{\text{int,W,other}} + \Phi_{\text{int,MSW}} \quad (37)$$

with

$$\Phi_{\text{int,HW,circ}} = q_{\text{int,W,circ}} L_{\text{W,circ}} \quad (38)$$

where

$\Phi_{\text{int,W,circ}}$ is the internal heat flow rate due to recoverable losses from a permanent or time-controlled hot water circulation system, expressed in watts;

$\Phi_{\text{int,W,other}}$ is the internal heat flow rate due to recoverable losses from hot water systems, excluding hot water circulation, expressed in watts;

$\Phi_{\text{int,MSW}}$ is the internal heat flow rate due to recoverable losses from mains water and sewage, expressed in watts;

$q_{\text{int,W,circ}}$ is the (time-average) internal heat flow rate due to recoverable losses from the hot water circulation system per metre length, expressed in watts per metre;

$L_{\text{W,circ}}$ is the pipe length of the hot water circulation system in the building zone considered, expressed in metres.

10.4.4.2 Heat from permanent hot water circulation

The value for the internal heat flow rate due to recoverable losses from a permanent hot water circulation system per metre length, $q_{\text{int,HW,circ}}$, shall be obtained from the relevant standard on hot water systems as specified in Annex A. The length, $L_{\text{W,circ}}$, shall include the length of the return-pipes, unless explicitly otherwise specified.

10.4.4.3 Heat from other hot water, mains water and sewage

The value for the internal heat flow rate due to recoverable losses from the hot water system other than hot water circulation, $\Phi_{\text{intW,other}}$, and the value for the internal heat flow rate due to recoverable losses from mains water and sewage, $\Phi_{\text{int,MSW}}$, shall be obtained from the relevant standard on hot water systems as specified in Annex A. Alternatively, it may be specified on a national basis, depending on building use and purpose of the calculation, that the sum of these two heat flow rates ($\Phi_{\text{int,W,other}} + \Phi_{\text{int,MSW}}$) may be neglected.

For detailed simulation methods the thermal radiative and convective portions are each 50 %, unless otherwise specified.

Alternative option:

As an alternative, it may be decided at national level, for reasons of simplification, that minor amounts of heat dissipated in the hot water system that are actually recoverable in the building are to be ignored in the calculation of the building energy need for heating and/or cooling and, instead, be dealt with in the calculation of the performance of the system by adequate adjustment factors.

NOTE If this concerns significant amounts of dissipation, the alternative option may lead to underestimation of energy needs for cooling and/or the thermal discomfort.

10.4.5 Heat dissipated from or to heating, cooling and ventilation systems

10.4.5.1 General

The internal heat flow rate due to recoverable losses from or to heating, cooling and ventilation systems, $\Phi_{\text{int,HVAC}}$, expressed in watts, is the sum of three terms as given by Equation (39):

$$\Phi_{\text{int,HVAC}} = \Phi_{\text{int,H}} + \Phi_{\text{int,C}} + \Phi_{\text{int,V}} \quad (39)$$

where

- $\Phi_{\text{int,H}}$ is the internal heat flow rate due to recoverable losses from the space heating system(s), expressed in watts;
- $\Phi_{\text{int,C}}$ is the internal heat flow rate due to recoverable losses from the space cooling system(s), expressed in watts;
- $\Phi_{\text{int,V}}$ is the internal heat flow rate due to recoverable losses from the ventilation system(s), expressed in watts.

For detailed simulation methods the thermal radiative and convective portions are each 50 %, unless otherwise stated.

NOTE The heat flow rate is counted positive, if from the system to the indoor environment; it is counted negative, if from the indoor environment to the system, e.g. the heat flow rate to cold pipes of the cooling system.

Iteration steps:

Before the recoverable losses from the heating and cooling system can be calculated, it might be necessary to calculate first the energy needs for heating and cooling without these elements in the internal heat gains. See 7.3.

ISO 13790:2008(E)

10.4.5.2 Space heating system

The value for the internal heat flow rate due to recoverable losses from the space heating system, $\Phi_{\text{int,H}}$, consists of heat dissipated in the building zone considered, from auxiliary energy sources (such as a pump, fan and/or electronics) and heat dissipated from emission (if not coinciding with the energy need, nor already taken into account by a correction on the temperature set-point), circulation, distribution, storage and generation of the heating system(s).

The value shall be obtained from the relevant standard on space heating systems as specified in Annex A, either (which may be decided at national level) as a variable per hour (only for detailed simulation methods or simple hourly method), or as average value per month or average over the heating season.

Alternative option:

As an alternative, for reasons of simplification, it may be decided at national level that minor amounts of heat dissipated in the space heating system that are actually recoverable in the building are to be ignored in the calculation of the building energy need for heating and cooling and, instead, be dealt with in the calculation of the performance of the heating system by adequate adjustment factors.

NOTE If this concerns significant amounts of dissipation, the alternative option might lead to underestimation of energy needs for cooling and/or the thermal discomfort.

10.4.5.3 Space cooling system

The value for the internal heat flow rate due to recoverable losses from or to the cooling system, $\Phi_{\text{int,C}}$, consists of heat from auxiliary energy sources (such as a pump, fan and/or electronics), dissipated in the considered building zone, and heat dissipated to cold emission (if not coinciding with the energy need), circulation, distribution, storage and generation parts of the cooling system(s).

The value shall be obtained from the relevant standard on cooling systems as specified in Annex A; in this respect it may be decided at national level to specify the value either as variable per hour (only for detailed simulation methods or simple hourly method), or as average value per month or average over the cooling season.

Alternative option:

As an alternative, for reasons of simplification, it may be decided at national level that minor amounts of heat dissipated to the cold parts of the space cooling system that are actually recoverable in the building are to be ignored in the calculation of the building energy need for heating and cooling and, instead, be dealt with in the calculation of the performance of the cooling system by adequate adjustment factors.

NOTE If this concerns significant amounts of dissipation, the alternative option might lead to underestimation of energy needs for cooling and/or the thermal discomfort.

10.4.5.4 Ventilation system

The value for the internal heat flow rate in the considered building zone due to recoverable losses from the ventilation system, $\Phi_{\text{int,V}}$, consists of heat, dissipated in the considered building zone, from the ventilation system(s). This value shall include heat dissipated in the air supplied to the building zone, for instance from the supply fan.

The value shall be obtained from the relevant standard on air flow rates and ventilation systems as specified in Annex A; in this respect it may be decided at national level to specify the value either as variable per hour (only for detailed simulation methods or simple hourly method), or as average value per month or average over the heating season and cooling season respectively.

NOTE Internal heat from ventilation systems not taken into account in the supply temperature could include heat dissipated from a fan-motor outside the air-stream or from fans circulating the air locally.

Alternative option:

As an alternative, for reasons of simplification, minor amounts of heat dissipated in the ventilation system that are actually recoverable in the building may be ignored in the calculation of the building energy need for heating and cooling and, instead, be dealt with in the calculation of the performance of the ventilation system by adequate adjustment factors.

This alternative option is permitted only if it can be ensured that this will not lead to underestimation of energy needs for heating, cooling and/or the thermal discomfort.

10.4.6 Heat from or to processes and goods

The internal heat flow rate due to recoverable losses from or to processes and goods, $\dot{\Phi}_{I,PROC}$, consists of heat from or to specific processes in the considered building zone and/or goods entering the building zone. The values may be determined on a national basis, depending on building use and purpose of the calculation.

For detailed simulation methods the thermal radiative and convective portions are each 50 %, unless otherwise stated.

If a heat source of a potentially significant magnitude has a source temperature that is close to the internal temperature, the amount of heat that is actually transferred is strongly dependent on the temperature difference between source and indoor environment. In that case the heat shall not be added to the internal heat gains, but the heat transfer shall be added to the heat transfer by transmission, determined in Clause 8.

11 Solar heat gains**11.1 Calculation procedure**

Heat gains from solar heat sources result from the solar radiation normally available in the locality concerned, the orientation of the collecting areas, the permanent and movable shading, the solar transmittance and absorption and thermal heat transfer characteristics of collecting areas. The coefficient that includes the characteristics and the area of the collecting surface (including the impact of shading) is called the effective collecting area.

The calculation procedure depends on the type of calculation method, but the assumptions (on environment conditions, user behaviour and controls) and the input data shall be the same for each type of calculation methods (seasonal, monthly, simple hourly and detailed simulation methods). See Table 7.

Table 7 — Calculation procedure for solar heat gains for the different types of methods

Type of method	Overall solar heat gains	Solar heat gain elements	Input data and boundary conditions
Seasonal or monthly method	11.2	11.3	11.4
Simple hourly method	11.2	11.3	11.4
Detailed simulation method	Not applicable	Not applicable	11.4

11.2 Overall solar heat gains

11.2.1 Monthly and seasonal method

For the monthly and seasonal method, the sum of the heat gains from solar sources in the considered building zone for the considered month or season, Q_{sol} , expressed in megajoules, are calculated by using Equation (40):

$$Q_{\text{sol}} = \left(\sum_k \Phi_{\text{sol,mn},k} \right) t + \left[\sum_l (1 - b_{\text{tr},l}) \Phi_{\text{sol,mn,u},l} \right] t \quad (40)$$

where

- $b_{\text{tr},l}$ is the adjustment factor for the adjacent unconditioned space with internal heat source l , defined in ISO 13789;
- $\Phi_{\text{sol,mn},k}$ is the time-average heat flow rate from solar heat source k , determined in accordance with 10.3, expressed in watts;
- $\Phi_{\text{sol,mn,u},l}$ is the time-average heat flow rate from solar heat source l in the adjacent unconditioned space, determined in accordance with 10.3, expressed in watts;
- t is the length of the considered month or season, in accordance with Annex F, expressed in megaseconds.

An adjacent unconditioned space is an unconditioned space outside the boundaries of the zones for the calculation of the energy needs for heating and cooling. In the case of an unconditioned space adjacent to more than one conditioned zone, the value of the heat flow rate by solar heat source l in the unconditioned space, $\Phi_{\text{sol,mn,u},l}$, shall be divided between the conditioned zones, weighted according to the floor areas per conditioned zone which are determined in 6.4.

In the case of a sunspace, the same equation applies if the detailed method in E.2 is applied. In the case of the simplified method, where internal and solar gains in the sunspace are already included in an adjusted value for b , the sunspace shall be ignored in Equation (40).

11.2.2 Simple hourly method

For the simple hourly method, the heat flow rate from solar heat sources in the considered building zone, Φ_{sol} , expressed in watts, is calculated for each hour as given by Equation (41):

$$\Phi_{\text{sol}} = \sum_k \Phi_{\text{sol},k} + \sum_l (1 - b_{\text{tr},l}) \Phi_{\text{sol,u},l} \quad (41)$$

Alternatively, it may be decided nationally to calculate the heat flow rate from solar heat sources in the considered building zone as a time average over a given period, as given by Equation (42):

$$\Phi_{\text{sol}} = \sum_k \Phi_{\text{sol,mn},k} + \sum_l (1 - b_{\text{tr},l}) \Phi_{\text{sol,mn,u},l} \quad (42)$$

where

- $b_{\text{tr},l}$ is the adjustment factor for the adjacent unconditioned space with solar heat source l , defined in ISO 13789;
- $\Phi_{\text{sol},k}$ is the hourly heat flow rate from solar heat source k , determined in accordance with 11.3, expressed in watts;

- $\Phi_{\text{sol,u},l}$ is the hourly heat flow rate from solar heat source l in the adjacent unconditioned space, determined in accordance with 11.3, expressed in watts;
- $\Phi_{\text{sol,mn},k}$ is the time-average heat flow rate from solar heat source k , determined in accordance with 11.3, expressed in watts;
- $\Phi_{\text{sol,mn,u},l}$ is the time-average heat flow rate from solar heat source l in the adjacent unconditioned space, determined in accordance with 11.3, expressed in watts.

11.3 Solar heat gain elements

11.3.1 General

This subclause establishes the heat flow by solar gains, based on the effective collecting areas of the relevant building elements and corrections for solar shading by external obstacles. It also provides a correction for the thermal radiation to the sky.

The collecting areas to be taken into consideration are the glazing (including any integrated or add-on solar shading provision), the external opaque elements, the internal walls and floors of sunspaces, and walls behind a transparent covering or transparent insulation. The characteristics depend on climate, time and location-dependent factors such as the sun's position and the ratio between direct and diffuse solar radiation. Consequently, the characteristics in general vary over time, both hourly and over the year. As a result, adequate mean or conservative values shall be selected that are appropriate for the purpose of the calculation (heating, cooling and/or summer comfort).

11.3.2 Heat flow by solar gains per building element

The heat flow by solar gains through building element k , $\Phi_{\text{sol},k}$, expressed in watts, is given by Equation (43):

$$\Phi_{\text{sol},k} = F_{\text{sh,ob},k} A_{\text{sol},k} I_{\text{sol},k} - F_{\text{r},k} \Phi_{\text{r},k} \quad (43)$$

where

- $F_{\text{sh,ob},k}$ is the shading reduction factor for external obstacles for the solar effective collecting area of surface k , determined in accordance with 11.4.4.
- $A_{\text{sol},k}$ is the effective collecting area of surface k with a given orientation and tilt angle, in the considered zone or space, determined in accordance with 11.3.3 (glazing), 11.3.4 (opaque building elements) and Annex E (special elements), expressed in square metres;
- $I_{\text{sol},k}$ is the solar irradiance, the mean energy of the solar irradiation over the time step of the calculation, per square metre of collecting area of surface k , with a given orientation and tilt angle, determined in accordance with Annex F, expressed in watts per square metres;
- $F_{\text{r},k}$ is the form factor between the building element and the sky determined in accordance with 11.4.6;
- $\Phi_{\text{r},k}$ is the extra heat flow due to thermal radiation to the sky from building element k , determined in accordance with 11.3.5, expressed in watts.

NOTE 1 The solar effective collecting area, A_{sol} , is equal to the area of a black body having the same solar heat gain as the surface considered.

NOTE 2 The extra heat flow due to thermal radiation to the sky is actually not a solar heat gain, but included with the solar gains for convenience.

11.3.3 Effective solar collecting area of glazed elements

The effective solar collecting area of a glazed envelope element (e.g. a window), A_{sol} , expressed in square metres, is given by Equation (44):

$$A_{sol} = F_{sh,gl} g_{gl} (1 - F_F) A_{w,p} \quad (44)$$

where

$F_{sh,gl}$ is the shading reduction factor for movable shading provisions, determined in accordance with 11.4.3;

g_{gl} is the total solar energy transmittance of the transparent part of the element, determined in accordance with 11.4.2;

NOTE The transparent part of the element can contain clear glazing, but also (permanent) scattering or solar shading layers.

F_F is the frame area fraction, ratio of the projected frame area to the overall projected area of the glazed element, determined in accordance with 11.4.5;

$A_{w,p}$ is the overall projected area of the glazed element (e.g. window area), expressed in square metres.

11.3.4 Effective collecting area of opaque building elements

The net solar heat gains of opaque elements without transparent insulation during the heating season can be only a small portion of the total solar heat gains and are partially compensated by radiation losses from the building to clear skies. However, for dark, poorly insulated surfaces, or large areas facing the sky, the solar heat gains through opaque elements can become important.

For summer cooling or summer thermal comfort calculations, the solar heat gains through opaque building elements should not be underestimated. On the other hand, if thermal radiation losses are expected to be important, the transmission heat loss can be augmented at the same time, which is represented by a correction factor to the effect of the solar heat gains. Solar heat gains of opaque elements with transparent insulation are treated in Clause H.2.

The effective solar collecting area of an opaque part of the building envelope, A_{sol} , expressed in square metres, is given by Equation (45):

$$A_{sol} = \alpha_{S,c} \times R_{se} \times U_c \times A_c \quad (45)$$

where

$\alpha_{S,c}$ is the dimensionless absorption coefficient for solar radiation of the opaque part, obtained from appropriate national sources;

R_{se} is the external surface heat resistance of the opaque part, determined in accordance with ISO 6946, expressed in square metre-kelvin per watt;

U_c is the thermal transmittance of the opaque part, determined in accordance with ISO 6946, expressed in watts per square metre-kelvin;

A_c is the projected area of the opaque part, expressed in square metres.

If the building element contains a layer that is (e.g. naturally) ventilated with external air and the U -value is calculated with the assumption that the thermal resistance between this vented layer and the external environment can be neglected, the solar transmittance using Equation (45) will be overestimated. To avoid overestimation, a corrected U -value should be used in Equation (45) in which the vented layer is not considered as a short-cut, but as a physical mechanism that removes part of the solar heat.

NOTE For example, in the case of rooves with (vented) roof tiles, calculated by reference to ISO 13789.

11.3.5 Thermal radiation to the sky

The extra heat flow due to thermal radiation to the sky for a specific building envelope element, Φ_r , expressed in watts, is given by Equation (46):

$$\Phi_r = R_{se} \times U_c \times A_c \times h_r \times \Delta\theta_{er} \quad (46)$$

where

- R_{se} is the external surface heat resistance of the element, determined in accordance with ISO 6946, expressed in square metre-kelvin per watt;
- U_c is the thermal transmittance of the element, determined in accordance with ISO 6946, expressed in watts per square metres kelvin;
- A_c is the projected area of the element, expressed in square metres;
- h_r is the external radiative heat transfer coefficient, determined in accordance with 11.4.6, expressed in watts per square metres kelvin;
- $\Delta\theta_{er}$ is the average difference between the external air temperature and the apparent sky temperature, determined in accordance with 11.4.6, expressed in degrees centigrade.

Alternatively, it may be decided at national level, depending on the application, to consider the extra heat flow due to thermal radiation to the sky as an extra transmission heat transfer, using an external operative temperature instead of the air temperature.

11.3.6 Solar heat gains of sunspaces

The effective collecting area of a sunspace, which has in most cases several collecting areas, cannot be calculated in a simple way. The calculation procedure is given in E.2.

11.4 Input data and boundary conditions

11.4.1 General

In the case of old existing buildings, if gathering the full required input would be too labour-intensive for the purpose, relative to the cost-effectiveness of gathering the input, a simplified procedure may be defined at national level. Specification of the conditions for allowing this simplified procedure may be made at national level, depending on the purpose of the calculation. In that case the user shall report which method has been used and from which source.

NOTE Example of possible simplification: ignore the effective solar collecting area in unconditioned spaces (except sunspaces).

11.4.2 Solar energy transmittance of glazed elements

In principle, the total solar energy transmittance, g_{gl} , in 11.3.3 [Equation (44)] is the time-averaged ratio of energy passing through the transparent element to that incident upon it.

For windows or other glazed envelope elements with non-scattering glazing, the solar energy transmittance for radiation perpendicular to the glazing, g_n , shall be calculated in accordance with the relevant standard on optical properties of multiple glazing as specified in Annex A.

ISO 13790:2008(E)

Because the time-averaged total solar energy transmittance value is somewhat lower than g_n , a correction factor, F_w , is used as given by Equation (47):

$$g_{gl} = F_w g_{gl,n} \quad (47)$$

where F_w is a correction factor for non-scattering glazing.

In the absence of national values, the value for the correction factor is $F_w = 0,90$.

For windows or other glazed envelope elements with scattering glazing or solar shading provisions, the solar energy transmittance for radiation perpendicular to the glazing (normal incidence), g_n , can significantly underestimate the time-average solar transmittance.

The time-average total solar energy transmittance is calculated according to the weighted sum as given by Equation (48):

$$g_{gl} = a_{gl} g_{gl,alt} + (1 - a_{gl}) g_{gl,dif} \quad (48)$$

where

a_{gl} is a weighting factor, representative of the position (orientation, tilt) of the window, climate and season;

$g_{gl,alt}$ is the solar energy transmittance for solar radiation from an altitude angle, alt_g , representative of the position (orientation, tilt) of the window, climate and season;

$g_{gl,dif}$ is the solar energy transmittance for isotropic diffuse solar radiation.

If the window comprises blinds with movable slats, the solar transmittance shall be calculated with the blinds at such a position that direct solar radiation from the angle, alt_{gl} , is blocked, but with maximum possible light transmittance and view through.

In the absence of national values, the following values shall be used:

$$a_{gl} = 0,75 \text{ and } alt_{gl} = 45.$$

NOTE 1 In the case of horizontal Venetian blinds with the slats in such a position (e.g. slightly inclined) that direct solar radiation is fully blocked, the solar energy transmission by diffuse radiation and by ground-reflected radiation can be significantly more than g_n .

The second right-hand term in the equation is a simplification, taking together the diffuse radiation from the direction of the sky plus the ground-reflected radiation.

EXAMPLE Double glazing with external white Venetian blinds: slats at 45° , thus blocking direct radiation (if fully closed, the light transmittance and view through would not be the maximum possible); typical values are:

$$g_{gl,45} = 0,045; g_{gl,dif} = 0,196 \rightarrow g_{gl} = 0,083.$$

NOTE 2 The values for a_{gl} and for alt_{gl} are in principle latitude-, climate-, season- and orientation-dependent. It is up to national bodies to decide whether and when such differentiation is needed.

In the case of old existing buildings, if gathering the full required input would be too labour-intensive for the purpose, relative to the cost-effectiveness of gathering the input, default g -values for windows with and without solar shading may be defined at national level. Specification of the conditions for allowing these default values may be made at national level, depending on the purpose of the calculation. In that case the user shall report which method has been used and from which source.

NOTE 3 Typical g -values are given in Clause G.5.

Detailed simulation methods:

Alternatively, the solar energy transmittance may be determined each hour, as a function of the sun position and contribution of diffuse and ground-reflected radiation. For scattering glazing or windows including solar shading provisions, this requires that the g -value is known for each (altitude and azimuth) angle of incidence.

11.4.3 Movable shading provisions**11.4.3.1 Monthly method and seasonal method**

For the monthly method and seasonal method, the shading reduction factor for movable shading provisions, $F_{sh,gl}$, shall be derived by using Equation (49):

$$F_{sh,gl} = \frac{[(1 - f_{sh,with})g_{gl} + f_{sh,with}g_{gl+sh}]}{g_{gl}} \quad (49)$$

where

- g_{gl} is the total solar energy transmittance of the window, when the solar shading is not in use;
- g_{gl+sh} is the total solar energy transmittance of the window, when the solar shading is in use;
- $f_{sh,with}$ is the weighted fraction of the time with the solar shading in use, e.g. as a function of the intensity of incident solar radiation (thus climate-, season- and orientation-dependent).

The weighted fraction of the time that the solar shading is in use, $f_{sh,with}$, is determined on the basis of the basic input data and hourly patterns.

In the case of intermittent heating or cooling where, in accordance with 13.2.2, the effect of intermittency is taken into account by a reduction factor on the energy need for heating or cooling, the weighted fraction shall be calculated assuming continuous heating or cooling, thus disregarding days with reduced heating or cooling set-point or switch-off.

NOTE Values of $f_{sh,with}$ are determined at national level. Examples are given in Annex G. EN 15232 describes different types of control systems.

11.4.3.2 Simple hourly method and detailed simulation methods

For the simple hourly method and detailed simulation methods, the choice between g_{gl} and g_{gl+sh} shall be made each hour.

11.4.4 External shading reduction factors**11.4.4.1 General**

The external shading reduction factor, $F_{sh,O}$, which is in the range 0 to 1, represents the reduction in incident solar radiation due to permanent shading of the surface concerned resulting from:

- other buildings;
- topography (hills, trees, etc.);
- overhangs;
- other elements of the same building;
- external part of the wall where the glazed element is mounted.

ISO 13790:2008(E)

The shading reduction factor, $F_{sh,O}$, is defined by Equation (50):

$$F_{sh,O} = \frac{I_{sol,ps,mean}}{I_{sol,mean}} \quad (50)$$

where

$I_{sol,ps,mean}$ is the average solar irradiance actually received on the collecting plane shaded by the external obstacle(s) during the considered heating and cooling season respectively, expressed in watts per square metre;

$I_{sol,mean}$ is the average solar irradiance on the collecting plane without shading, expressed in watts per square metre.

It may be decided at national level, depending on specific conditions (such as type of external obstacles) to use a fixed shading reduction factor for different windows in the building with the same orientation.

NOTE The shading by different obstacles can coincide, partly or as a whole. Consequently, adding the shading reduction factors can significantly overestimate the shading.

Unless otherwise specified nationally, the calculation of the shading reduction factors shall be based upon the following simplification.

Direct solar radiation is obstructed by the obstacle; diffuse and ground-reflected radiation remains unchanged. This is equivalent to obstacles that, by reflection, produce the same amount of solar radiation as they obstruct.

11.4.4.2 Simple hourly method and detailed simulation methods

It may be decided at national level to either specify time-average tabulated values or use different values for each hour.

11.4.4.3 All methods

For specific applications, tabulated shading reduction factors may be prescribed at national level, depending on application and building type.

NOTE Annex G provides some informative data on shading reduction factors.

In the case of old existing buildings, if gathering the full required input would be too labour-intensive for the purpose, relative to the cost-effectiveness of gathering the input, simple methods and/or default values may be defined at national level. Specification of the conditions for allowing these simple methods or values may be made at national level, depending on the purpose of the calculation. In that case the user shall report which method or values have been used and from which source.

11.4.5 Frame area fraction

For each window the frame area fraction shall be determined in accordance with ISO 10077-1.

As an alternative it may be decided nationally to use a fixed frame area fraction for all windows in the building.

NOTE For instance, in the case of heating-dominated climates, use 0,20 or 0,30, whichever gives the higher thermal transmittance value of the window (see 8.3.1), or a fixed value of 0,30; for cooling-dominated climates use a fixed value of 0,20. Compare similar procedures for the thermal transmission through windows in 8.3.2.1.

11.4.6 Extra heat transfer by thermal radiation to the sky

The values for the form factor for radiation between the element and the sky are:

$F_r = 1$ for an unshaded horizontal roof;

$F_r = 0,5$ for an unshaded vertical wall.

The external radiative heat transfer coefficient, h_r , expressed in watts per square metres per kelvin, may be approximated as given by Equation (51):

$$h_r = 4 \varepsilon \sigma (\theta_{ss} + 273)^3 \quad (51)$$

where

ε is the emissivity for thermal radiation of the external surface;

σ is the Stefan-Boltzmann constant: $\sigma = 5,67 \times 10^{-8} \text{ W}/(\text{m}^2 \cdot \text{K}^4)$;

θ_{ss} is the arithmetic average of the surface temperature and the sky temperature, expressed in degrees centigrade.

To a first approximation, h_r can be taken equal to $5\varepsilon \text{ W}/(\text{m}^2 \cdot \text{K})$, which corresponds to an average temperature of 10°C .

When the sky temperature is not available from climatic data, the average difference, $\Delta\theta_{er}$, between the external air temperature and the sky temperature should be taken as 9 K in sub-polar areas, 13 K in the tropics and 11 K in intermediate zones.

At national level, default values may be given for the necessary input data, depending on the application and type of building. It may also be decided at national level, depending on the climate and purpose of the calculation, to ignore the extra heat transfer by radiation to the sky, either as such, or in combination with ignoring solar heat absorbed by opaque construction elements.

NOTE 1 Examples of default values are given in Annex G.

NOTE 2 For detailed simulation methods, it may also be necessary to use time-average values if this is needed in order to force the surface heat transfer coefficients to be in line with the required standard values.

12 Dynamic parameters

12.1 Calculation procedure

A dynamic method models the thermal resistances, thermal capacitances and heat gains from solar and internal heat sources in the building zone. There are numerous methods to do so, ranging in complexity from simple to very detailed. The simple hourly method combines the thermal capacity of the building zone into a single resistance-capacitance pair.

In the monthly and seasonal methods, the dynamic effects are taken into account by introducing the gain utilization factor for heating and the loss utilization factor for cooling. The effect of inertia in the case of intermittent heating or switch-off is taken into account separately; see Clause 13.

Although the calculation procedure depends on the type of calculation method, the assumptions (on environment conditions, user behaviour and controls) and the input data shall be the same for each type of calculation method (seasonal, monthly, simple hourly and detailed simulation methods). See Table 8.

Table 8 — Calculation procedure for dynamic parameters for the different types of methods

Type of method	Dynamic parameters	Input data and boundary conditions
Seasonal or monthly method	12.2	12.3
Simple hourly method	12.2	12.3
Detailed simulation method	Not applicable	12.3

12.2 Dynamic parameters

12.2.1 Monthly and seasonal method

12.2.1.1 Gain utilization factor for heating

The dimensionless gain utilization factor for heating, $\eta_{H,gn}$, is a function of the heat-balance ratio, γ_H , and a numerical parameter, a_H , that depends on the building inertia, as given by Equations (52) to (55):

$$\text{if } \gamma_H > 0 \text{ and } \gamma_H \neq 1: \quad \eta_{H,gn} = \frac{1 - \gamma_H^{a_H}}{1 - \gamma_H^{a_H+1}} \quad (52)$$

$$\text{if } \gamma_H = 1: \quad \eta_{H,gn} = \frac{a_H}{a_H + 1} \quad (53)$$

$$\text{if } \gamma_H < 0: \quad \eta_{H,gn} = 1 / \gamma_H \quad (54)$$

with

$$\gamma_H = \frac{Q_{H,gn}}{Q_{H,ht}} \quad (55)$$

where (for each month or per season and for each building zone)

γ_H is the dimensionless heat-balance ratio for the heating mode;

$Q_{H,ht}$ is the total heat transfer for the heating mode, determined in accordance with 7.2.1.3, expressed in megajoules;

$Q_{H,gn}$ represents the total heat gains for the heating mode, determined in accordance with 7.2.1.3, expressed in megajoules;

a_H is a dimensionless numerical parameter depending on the time constant, τ_H , defined by Equation (56):

$$a_H = a_{H,0} + \frac{\tau}{\tau_{H,0}} \quad (56)$$

where

$a_{H,0}$ is a dimensionless reference numerical parameter, determined in accordance with Table 9;

τ is the time constant of the building zone, determined in accordance with 12.2.1.3, expressed in hours;

$\tau_{H,0}$ is a reference time constant, determined in accordance with Table 9, expressed in hours.

The parameter values are empirical values and may also be determined at national level, depending on the purpose of the calculation; in the absence of national values the given tabulated values may be used.

NOTE 1 See also Annex I for explanation and derivation and Annex H for justification and future conversion.

Table 9 — Values of the numerical parameter, $a_{H,0}$, and reference time constant, $\tau_{H,0}$

Type of method	$a_{H,0}$	$\tau_{H,0}$ h
Monthly calculation method	1,0	15
Seasonal calculation method	0,8	30
Values of $a_{H,0}$ and $\tau_{H,0}$ may also be provided at national level.		

Figure 5 illustrates gain utilization factors for the monthly calculation method and for various time constants.

NOTE 2 The gain utilization factor is defined independently of the heating system characteristics, assuming perfect temperature control and infinite flexibility. A slowly responding heating system and a less-than-perfect control system can significantly affect the use of the heat gains.

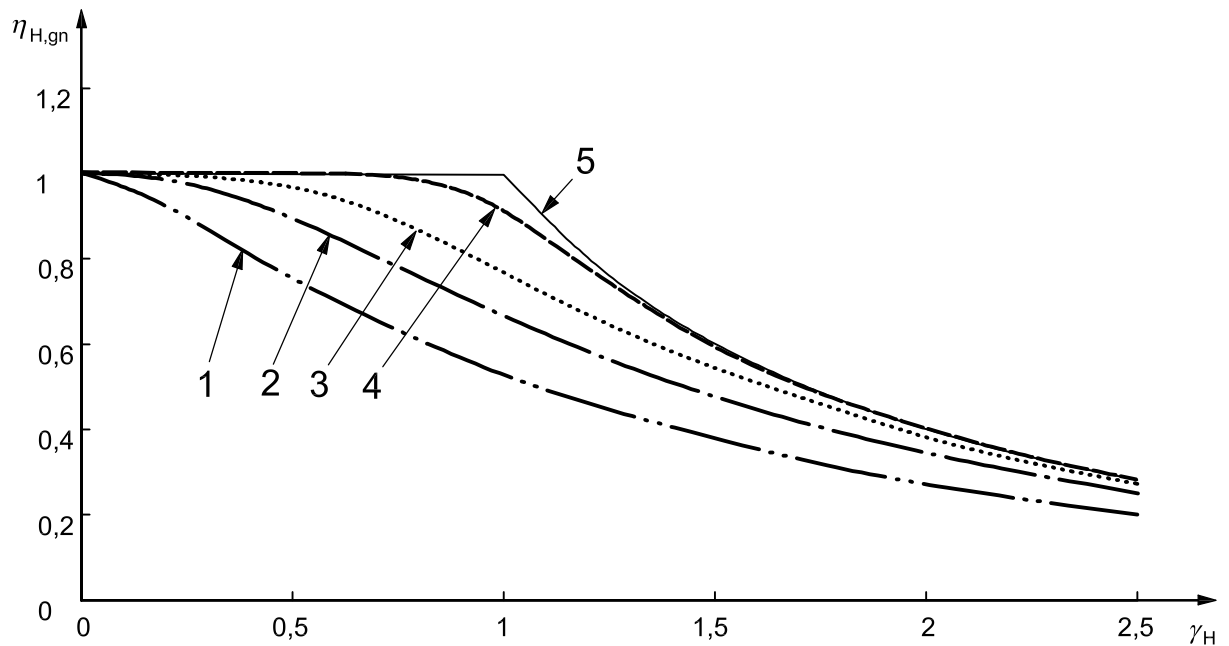

Key

- 1 time constant of 8 h (low inertia)
- 2 time constant of 1 d
- 3 time constant of 2 d
- 4 time constant of 7 d
- 5 time constant infinite (high inertia)

Figure 5 — Illustration of gain utilization factor for heating mode, for 8 h, 1 d, 2 d, 7 d and infinite time constants, valid for monthly calculation method

12.2.1.2 Loss utilization factor for cooling

The dimensionless loss utilization factor for cooling, $\eta_{C,ls}$, needed for the monthly or seasonal cooling method, is a function of the heat-balance ratio for cooling, γ_C , and a numerical parameter, a_C , that depends on the building thermal inertia, as given by Equations (57) to (60):

$$\text{if } \gamma_C > 0 \text{ and } \gamma_C \neq 1: \quad \eta_{C,ls} = \frac{1 - \gamma_C^{-a_C}}{1 - \gamma_C^{-(a_C+1)}} \quad (57)$$

$$\text{if } \gamma_C = 1: \quad \eta_{C,ls} = \frac{a_C}{a_C + 1} \quad (58)$$

$$\text{if } \gamma_C < 0: \quad \eta_{C,ls} = 1 \quad (59)$$

with

$$\gamma_C = \frac{Q_{C,gn}}{Q_{C,ht}} \quad (60)$$

where (for each month or per season and each building zone)

γ_C is the dimensionless heat-balance ratio for the cooling mode;

$Q_{C,ht}$ is the total heat transfer by transmission and ventilation for the cooling mode, determined in accordance with 7.2.1.3, expressed in megajoules;

$Q_{C,gn}$ represent the total heat gains for the cooling mode, determined in accordance with 7.2.1.3, expressed in megajoules;

a_C is a dimensionless numerical parameter depending on the time constant, τ_C , defined by Equation (61):

$$a_C = a_{C,0} + \frac{\tau}{\tau_{C,0}} \quad (61)$$

where

$a_{C,0}$ is a dimensionless reference numerical parameter, determined in accordance with Table 10;

τ is the time constant of the building zone, determined in accordance with 12.2.1.3, expressed in hours;

$\tau_{C,0}$ is a reference time constant, determined in accordance with Table 10, expressed in hours.

Values of $a_{C,0}$ and $\tau_{C,0}$ are given in Table 10.

The parameter values are empirical values and may also be determined at national level, depending on the purpose of the calculation; in the absence of national values the given tabulated values may be used.

NOTE 1 See also Annex I for explanation and procedures for the derivation of the parameter values. Bibliography [13] and section 2.1 of [23] provide background information on the development of the method.

Table 10 — Values of the numerical parameter, $a_{C,0}$, and reference time constant, $\tau_{C,0}$

Type of method	$a_{C,0}$	$\tau_{C,0}$ h
Monthly calculation method	1,0	15
Seasonal calculation method	0,8	30
Values of $a_{C,0}$ and $\tau_{C,0}$ may also be provided at national level.		

NOTE 2 The loss utilization factor is defined independently of the cooling system characteristics, assuming perfect temperature control and infinite flexibility. A slowly responding cooling system and a less-than-perfect control system can significantly affect the utilization of the losses.

Figure 6 illustrates loss utilization factors for the monthly calculation method and for various time constants.

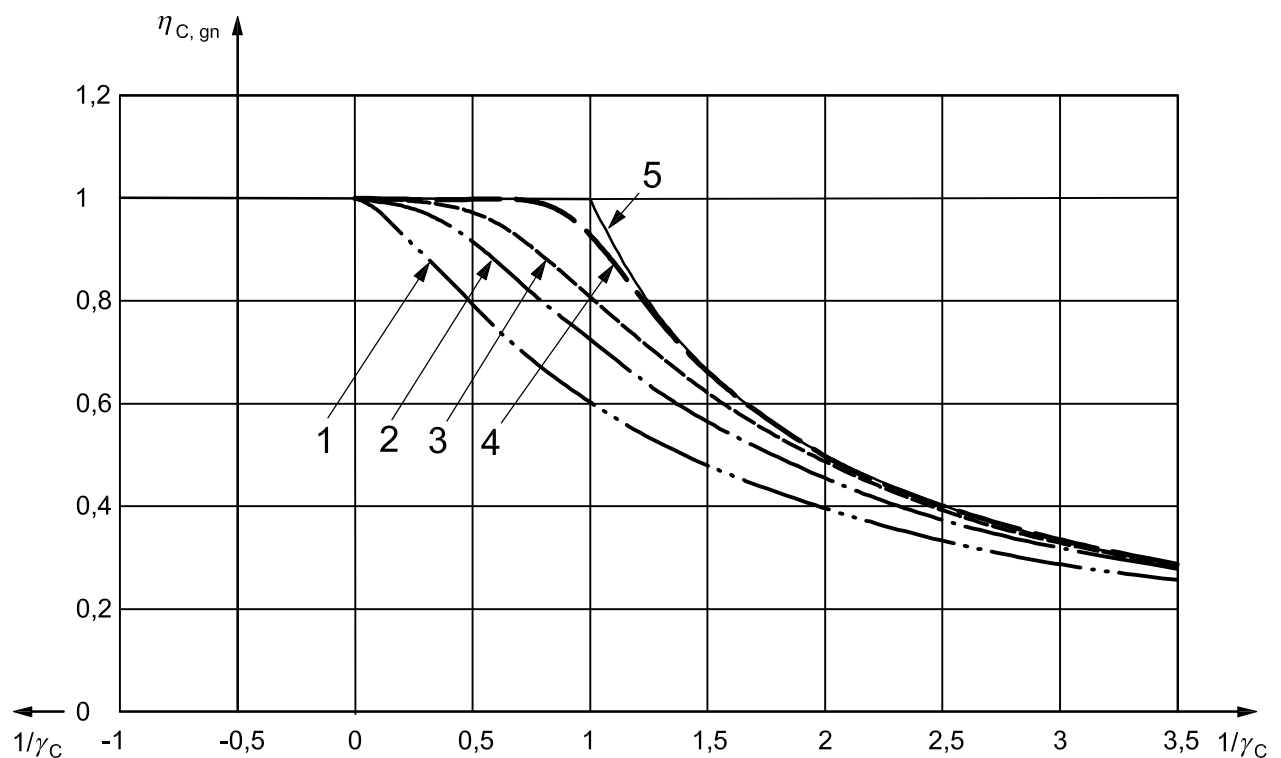

Key

- 1 time constant of 8 h (low inertia)
- 2 time constant of 1 d
- 3 time constant of 2 d
- 4 time constant of 7 d
- 5 time constant infinite (high inertia)

Figure 6 — Illustration of loss utilization factor for 8 h, 1 d, 2 d, 7 d and infinite time constants, valid for monthly calculation method

12.2.1.3 Building time constant

The time constant of the building zone, τ , expressed in hours, characterizes the internal thermal inertia of the conditioned zone both for the heating and cooling periods. It is calculated by using Equation (62):

$$\tau = \frac{C_m / 3600}{H_{tr,adj} + H_{ve,adj}} \quad (62)$$

where

C_m is the internal heat capacity of the building or building zone, calculated in accordance with 12.3.1, expressed in joules per kelvin;

NOTE 1 See discussion in Clause G.7 about whether or not the corrected internal heat capacity should be used, including the surface resistance, in accordance with A.3 in ISO 13786:2007.

$H_{tr,adj}$ is a representative value of the overall heat transfer coefficient by transmission, adjusted for the indoor-outdoor temperature difference, calculated in accordance with 8.3, expressed in watts per kelvin;

$H_{ve,adj}$ is a representative value of the overall heat transfer coefficient by ventilation, adjusted for the indoor-outdoor temperature difference, calculated in accordance with 9.3, expressed in watts per kelvin.

Representative values of $H_{tr,adj}$ and $H_{ve,adj}$ are values that are representative for the dominating (heating or cooling) season, to be determined in accordance with a procedure that may be specified at national level.

NOTE 2 For example, the monthly value for a mid-winter month in the case of a heating-dominated climate, or the monthly value for a mid-summer month in the case of a cooling-dominated climate.

Alternatively, it may be decided nationally, for specific applications and building types, to use default values as a function of the type of construction. In the absence of national values, the values from 12.3.1.2 may be used. The values can be approximate, and a relative uncertainty ten times higher than that of the heat transfer is acceptable.

12.2.2 Simple hourly method; coupling to thermal mass

The split of the transmission heat transfer coefficient for opaque elements H_{op} into H_{em} and H_{ms} (see 7.2.2) is calculated by using Equations (63) and (64):

$$H_{em} = 1 / (1/H_{op} - 1/H_{ms}) \quad (63)$$

and:

$$H_{ms} = h_{ms} A_m \quad (64)$$

where

H_{ms} is the coupling conductance between nodes m and s, expressed in watts per kelvin;

h_{ms} is the heat transfer coefficient between nodes m and s, with fixed value $h_{ms} = 9,1$, expressed in watts per square metres kelvin;

A_m is the effective mass area, expressed in square metres.

The effective mass area, A_m , is calculated by using Equation (65):

$$A_m = \frac{C_m^2}{\left(\sum \times A_j \times \kappa_j^2\right)} \quad (65)$$

where

A_m is the effective mass area, expressed in square metres;

C_m is the internal heat capacity, determined in accordance with 12.3.1, expressed in joules per kelvin;

A_j is the area of the element j , expressed in square metres;

κ_j is the internal heat capacity per area of the building element j , determined in accordance with 12.3.1, expressed in joules per square metres kelvin.

Alternatively, it may be decided nationally, for specific applications and building types, to use default values as a function of the type of construction. In the absence of national values, the values from 12.3.1.2 may be used. The values can be approximate, and a relative uncertainty ten times higher than that of the heat transfer is acceptable.

12.3 Boundary conditions and input data

12.3.1 Monthly, seasonal and simple hourly method

12.3.1.1 Internal heat capacity of the building

For the monthly and seasonal method, the internal heat capacity of the building zone, C_m , expressed in joules per kelvin, is calculated by summing the heat capacities of all the building elements in direct thermal contact with the internal air of the zone under consideration, as given by Equation (66):

$$C_m = \sum \times \kappa_j \times A_j \quad (66)$$

where

κ_j is the internal heat capacity per area of the building element j , determined in accordance with Clause 7 of ISO 13786:2007 (detailed method) or, as a more simple alternative, in accordance with Annex A of ISO 13786:2007, with maximum effective thickness as given in Table 11, expressed in joules per square metres kelvin;

A_j is the area of the element j , expressed in square metres.

NOTE See discussion in Clause G.7 about whether or not a correction is needed for the internal heat capacity for the monthly and seasonal method, to take into account the surface resistance.

For the simple hourly method, the internal heat capacity of the building zone, C_m , expressed in joules per kelvin, is calculated by summing the heat capacities of all the building elements in direct thermal contact with the internal air of the zone under consideration, also by using Equation (66).

Table 11 — Maximum thickness to be considered for internal heat capacity

Application	Maximum thickness m
Determination of the gain or loss utilization factor (period of variations: 1 d)	0,10

Alternatively, it may be decided nationally, for specific applications and building types, to use default values as a function of the type of construction. In the absence of national values, the values from 12.3.1.2 may be used. The values may be approximate, and a relative uncertainty ten times higher than that of the heat transfer is acceptable.

12.3.1.2 Default values for dynamic parameters

In the absence of national values, the values listed in Table 12 may be used.

Table 12 — Default values for dynamic parameters

Class ^a	Monthly and seasonal method	Simple hourly method	
	C_m J/K ^b	A_m m ²	C_m J/K
Very light	$80\,000 \times A_f$	$2,5 \times A_f$	$80\,000 \times A_f$
Light	$110\,000 \times A_f$	$2,5 \times A_f$	$110\,000 \times A_f$
Medium	$165\,000 \times A_f$	$2,5 \times A_f$	$165\,000 \times A_f$
Heavy	$260\,000 \times A_f$	$3,0 \times A_f$	$260\,000 \times A_f$
Very heavy	$370\,000 \times A_f$	$3,5 \times A_f$	$370\,000 \times A_f$

^a May be specified at national level.

^b See discussion in Clause G.7 about whether or not a correction is needed for the internal heat capacity for the monthly and seasonal method, to take into account the surface resistance.

12.3.2 Detailed simulation methods

For detailed dynamic simulation methods, the input data on heat transmission elements are in general more detailed than for the seasonal, monthly or simple hourly methods. The heat capacities and thermal resistances of all layers of all building elements shall be based upon the same layers as used in 8.4 (thermal transmission properties).

13 Indoor conditions

13.1 Different modes

There are different modes for heating and cooling to consider, such as:

- continuous or quasi-continuous heating and/or cooling at constant set-point;
- night-time and/or weekend reduced set-point or switch-off;
- unoccupied periods (e.g. holidays);
- complicated situations, such as periods with boost modes, with (optionally) a maximum heating or cooling power during the boost period.

The procedures are partly general and partly applicable to specific types of methods only. A summary is given in Table 13.

Table 13 — Calculation procedures for the different heating and/or cooling modes, for the different types of methods

Type of method	Continuous or quasi-continuous heating or cooling	Intermittent heating or cooling ^a	Unoccupied periods	Complicated situations ^b
Seasonal method	13.2.1	13.2.2	Method less applicable ^a	Method less applicable ^a
Monthly method	13.2.1	13.2.2	In addition: 13.2.4	Method less applicable ^a
Simple hourly method	13.2.3	13.2.3	In addition: 13.2.4	13.2.3
Detailed simulation method	13.2.3	13.2.3	In addition: 13.2.4	13.2.3

^a If not meeting the conditions for calculation as continuous heating or cooling as given in Clause 13.2.1.

^b Such as periods with reduced heating or cooling power, boost modes, with (optionally) a maximum heating or cooling power during the boost period.

It may be decided at national level to replace the set-point temperature by a corrected set-point temperature to take into account the impact of imperfect control and emission. If applied, it shall be done, in accordance with the relevant standards for heating systems (if heated only) and cooling systems (if heated and/or cooled) specified in Annex A.

13.2 Calculation procedures

13.2.1 Continuous and quasi-continuous heating or cooling mode, monthly and seasonal method

13.2.1.1 Continuous heating and/or cooling

For continuous heating during the whole heating period one shall use as set-point temperature of the building zone, the set-point temperature for heating, $\theta_{i,H,set}$, expressed in degrees centigrade.

For continuous cooling during the whole cooling period one shall use as set-point temperature of the building zone, the set-point temperatures for cooling, $\theta_{i,C,set}$, expressed in degrees centigrade.

NOTE For the monthly methods, the actual mean internal temperature can be higher in the heating mode due to instantaneous overheating; however, this is taken into account by the gain utilization factor; similarly, for the cooling mode the actual mean internal temperature can be lower due to instantaneous high heat losses.

13.2.1.2 Quasi-continuous heating and/or cooling

Intermittent heating and/or cooling shall be considered as continuous heating and/or cooling with adjusted set-point temperature if mode A or mode B applies.

Mode A:

- If the set-point temperature variations between normal heating or cooling and reduced heating or cooling periods are less than 3 K and/or
- if the time constant of the building (see 12.2.1.3) is less than $\times 0,2$ the duration of the shortest reduced heating period (for heating) or cooling period (for cooling).

The set-point temperature for the calculation is the time average of the set-point temperatures. See illustration in Figures 7 a) and 7 b).

Mode B:

If the time constant of the building (see 12.2.1.3) is greater than three times the duration of the longest reduced heating period. The set-point temperature for the calculation is the set-point temperature for the normal heating mode. See illustration in Figure 7 c).

Similarly, if the time constant of the building (see 12.2.1.3) is greater than three times the duration of the longest reduced cooling period. The set-point temperature for the calculation is the set-point temperature for the normal cooling mode.

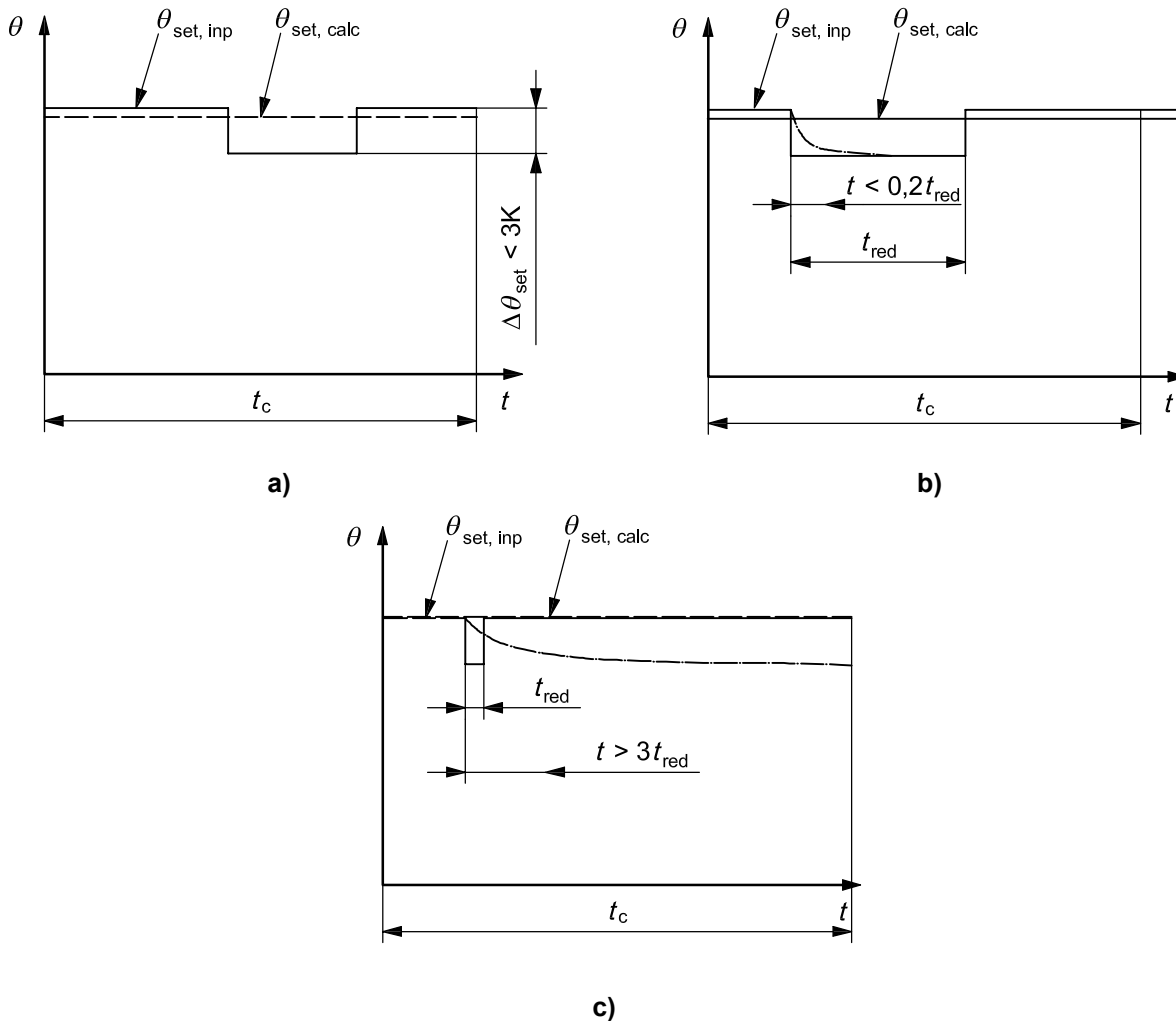

Key

The cases a, b and c represent different situations as described in the text.

$\theta_{set,inp}$	set-point temperature provided as input
$\theta_{set,calc}$	set-point temperature for the calculation
t	time
t_c	representative part of the calculation period

A similar illustration applies for cooling (with reduced set-point higher than normal set-point instead of lower).

Figure 7 — Example of quasi-continuous heating

For the correction for a long unoccupied (e.g. holiday) period: see 13.2.4.

The values of the set-points shall be determined in accordance with 13.3.

13.2.2 Corrections for intermittency: monthly and seasonal method

13.2.2.1 Heating

In the case of intermittent heating which does not fulfil the conditions in the previous clause, the energy need for heating, $Q_{H,nd,interm}$, expressed in megajoules, is calculated by using Equation (67):

$$Q_{H,nd,interm} = a_{H,red} Q_{H,nd,cont} \quad (67)$$

where

$Q_{H,nd,cont}$ is the energy need for continuous heating, calculated in accordance with 7.2.1.1, expressed in megajoules;

$a_{H,red}$ is the dimensionless reduction factor for intermittent heating, determined in accordance with Equation (68).

NOTE 1 Occupant-related data for intermittent heating applies.

The dimensionless reduction factor for intermittent heating, $a_{H,red}$ is calculated as given by Equation (68):

$$a_{H,red} = 1 - b_{H,red}(\tau_{H,0}/\tau)^{\gamma_H}(1 - f_{H,hr}) \quad (68)$$

with minimum value: $a_{red,H} = f_{H,hr}$ and maximum value: $a_{H,red} = 1$.

where

$f_{H,hr}$ is the fraction of the number of hours in the week with a normal heating set-point (no reduced set-point or switch-off), e.g. $(14 \times 5)/(24 \times 7) = 0,42$;

$b_{H,red}$ is an empirical correlation factor; value $b_{H,red} = 3$;

τ is the time constant of the building zone, determined in accordance with 12.2.1.3, expressed in hours;

$\tau_{H,0}$ is the reference time constant for the heating mode, determined in accordance with 12.2.1.1, expressed in hours;

γ_H is the heat-balance ratio for the heating mode, determined in accordance with 12.2.1.1.

NOTE 2 For long intermittency periods such as holidays, the equation is equal to the general procedure given for long unoccupied periods in 13.2.4, with the only difference that, for long intermittency periods, a second term is added to account for possible heating at reduced set-point during the unoccupied period.

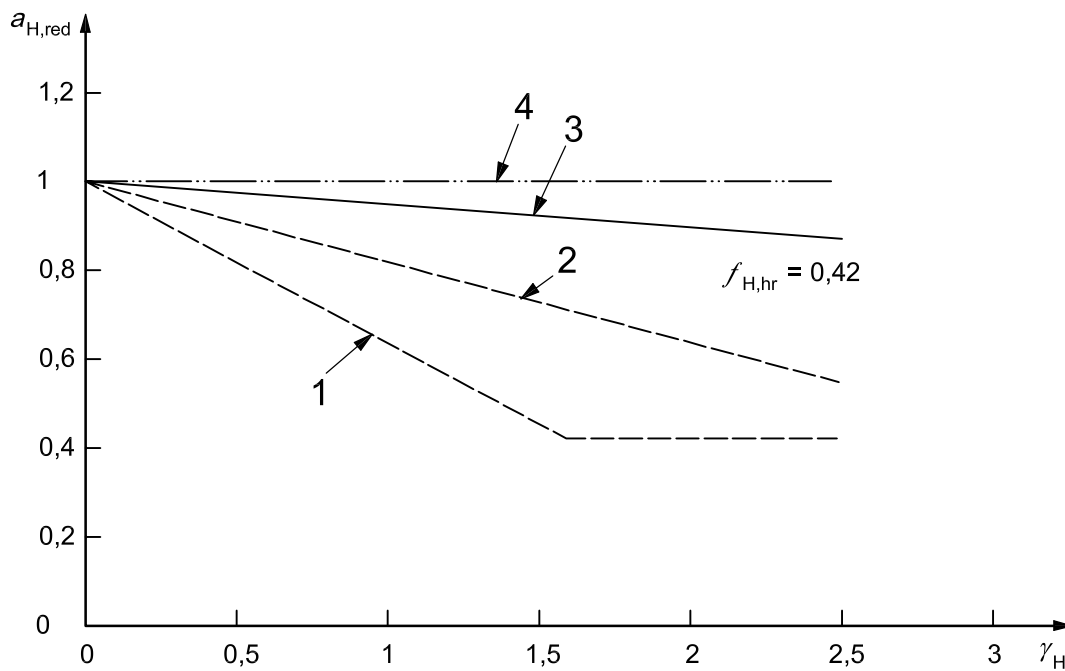

a) $f_{H,hr} = 0,42$: normal heating over 5 d, 14 h/d

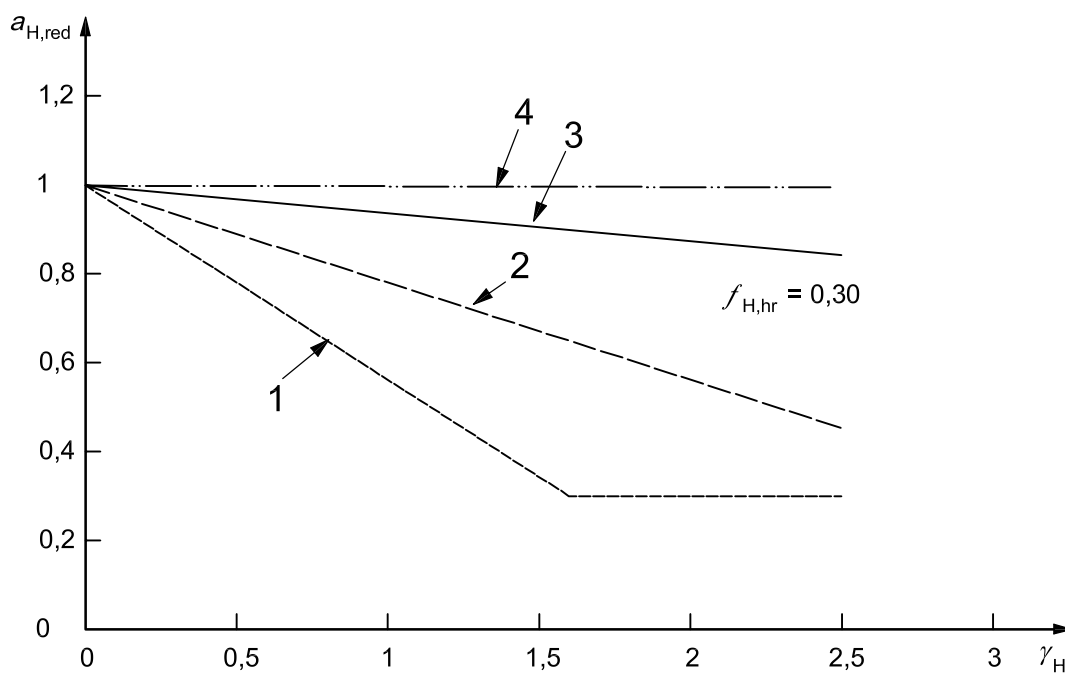

b) $f_{H,hr} = 0,30$: normal heating over 5 d, 10 h/d

Key

- 2 time constant of 1 d (low inertia)
- 3 time constant of 2 d
- 4 time constant of 7 d
- 5 time constant infinite (high inertia)

Figure 8 — Illustration of reduction factor for intermittent heating, for two different intermittency lengths

The heating system is assumed to deliver sufficient heating power to enable intermittent heating.

Alternatively, it may be decided at national level to use a national method for taking into account the effect of intermittency.

13.2.2.2 Cooling

In the case of intermittent cooling which does not fulfil the conditions in the previous clause, the energy need for cooling, $Q_{C,nd,interm}$, expressed in megajoules, is calculated as given by Equation (69):

$$Q_{C,nd,interm} = a_{C,red} Q_{C,nd,cont} \quad (69)$$

where

$Q_{C,nd,cont}$ is the energy need for cooling, calculated in accordance with 7.2.1.2, expressed in megajoules;

$a_{C,red}$ is the dimensionless reduction factor for intermittent cooling, determined in accordance with Equation (70);

NOTE 1 Occupant-related data for intermittent cooling applies.

The dimensionless reduction factor for intermittent cooling, $a_{C,red}$, is calculated as given by Equation (70):

$$a_{C,red} = 1 - b_{C,red}(\tau_{C,0}/\tau)\gamma_C(1 - f_{C,day}) \quad (70)$$

with minimum value: $a_{C,red} = f_{N,C}$ and maximum value: $a_{C,red} = 1$.

where

$f_{C,day}$ is the fraction of the number of days in the week with, at least during daytime, normal cooling set-point (no reduced set-point or switch-off) (e.g. 5/7 = 0,71);

$b_{C,red}$ is an empirical correlation factor; value $b_{C,red} = 3$;

τ is the time constant of the building zone, determined in accordance with 12.2.1.3, expressed in hours;

$\tau_{C,0}$ is the reference time constant for the cooling mode, determined in accordance with 12.2.1.2, expressed in hours;

γ_C is the heat-balance ratio for the cooling mode, determined in accordance with 12.2.1.2.

NOTE 2 For long intermittency periods such as holidays, the equation is equal to the general procedure given for long unoccupied periods in 13.2.4, with the only difference that for long intermittency periods a second term is added to count for possible cooling at reduced set-point during the unoccupied period.

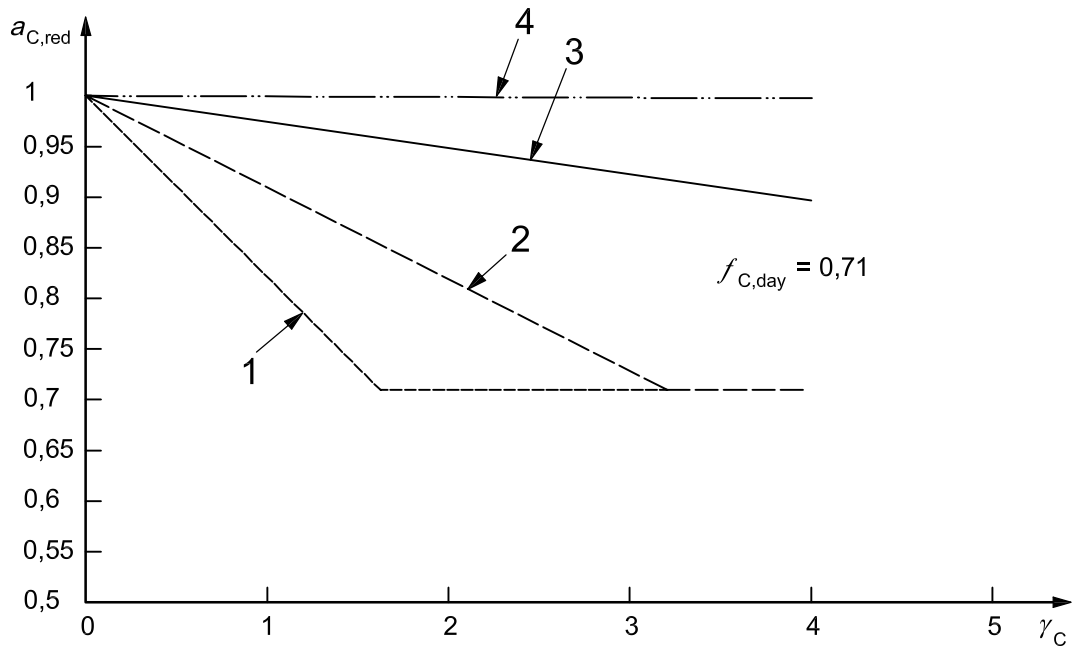
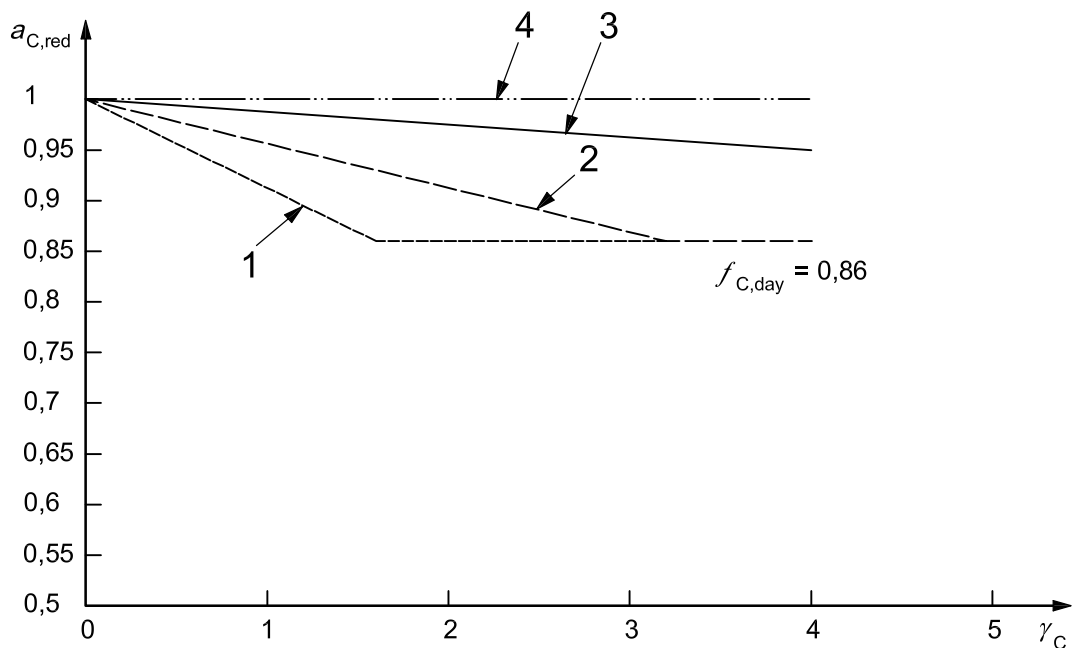
a) $f_{C,day} = 0,71$: normal cooling over 5 db) $f_{C,day} = 0,86$: normal cooling over 6 d**Key**

- 1 time constant of 1 d (low inertia)
- 2 time constant of 2 d
- 3 time constant of 7 d
- 4 time constant infinite (high inertia)

Figure 9 — Illustration of reduction factor for intermittent cooling, for two different intermittency lengths

The cooling system is assumed to deliver sufficient cooling power to enable intermittent cooling.

Alternatively, it may be decided at national level to use a national method for taking into account the effect of intermittency.

13.2.3 Set-points, simple hourly and detailed simulation methods

For continuous heating during the whole heating period, the minimum internal operative temperature of the building zone, θ_{nt} , shall be the set-point temperature for heating, expressed in degrees centigrade.

For continuous cooling during the whole cooling period, the maximum internal operative temperature of the building zone, θ_{nt} , shall be the set-point temperature for cooling, expressed in degrees centigrade.

For intermittent heating and/or cooling, the set-points shall be based upon hourly and weekly schedules, taking into account reduced set-points, switch-off periods and (if applicable) periods with boost modes, with (optionally) a maximum heating or cooling power during the boost period.

NOTE EN 15251 requires that the temperature setting be based on the operative temperature, because the operative temperature is more closely related to the comfort temperature than the air temperature. See Annex C for calculation of the operative temperature for the simple hourly method.

For the correction for an unoccupied (e.g. holiday) period: see 13.2.4.

The values of the set-points shall be determined in accordance with 13.3.

13.2.4 Corrections for unoccupied period (monthly, simple hourly and detailed simulation methods)

In some buildings, such as schools, unoccupied periods during the heating or cooling season, such as holiday periods, lead to a reduction in space heating or cooling energy use.

The heating and cooling needs, taking into account unoccupied period, $Q_{H,nd}$ and $Q_{C,nd}$, expressed in megajoules, are calculated as follows. For the month which contains an unoccupied period, perform the calculation twice: a) for occupied (normal) heating/cooling settings) and b) for unoccupied settings and then interpolate the results linearly according to the time fraction of unoccupied mode versus occupied mode, as given by Equations (71) and (72):

$$Q_{H,nd} = (1 - f_{H,nocc}) (Q_{H,nd,occ} + f_{H,nocc}) Q_{H,nd,nocc} \quad (71)$$

$$Q_{C,nd} = (1 - f_{C,nocc}) (Q_{C,nd,occ} + f_{C,nocc}) Q_{C,nd,nocc} \quad (72)$$

where

$Q_{H,nd,occ}$ is the energy need for heating, calculated in accordance with 7.2.1.1 (either $Q_{H,nd,cont}$ or $Q_{H,nd,interm}$), assuming for all days of the month the control and thermostat settings of the occupied period, expressed in megajoules;

$Q_{C,nd,occ}$ is the energy need for cooling, calculated in accordance with 7.2.1.2 (either $Q_{C,nd,cont}$ or $Q_{C,nd,interm}$), assuming for all days of the month the control and thermostat settings of the occupied period, expressed in megajoules;

$Q_{H,nd,nocc}$ is the energy need for heating, calculated in accordance with 7.2.1.1 (either $Q_{H,nd,cont}$ or $Q_{H,nd,interm}$), assuming for all days of the month the control and thermostat settings of the unoccupied period, expressed in megajoules;

$Q_{C,nd,nocc}$ is the energy need for cooling, calculated in accordance with 7.2.1.2 (either $Q_{C,nd,cont}$ or $Q_{C,nd,interm}$), assuming for all days of the month the control and thermostat settings of the unoccupied period, expressed in megajoules;

$f_{H,nocc}$ is the fraction of the month which is the unoccupied (heating) period (e.g. 10/31);

$f_{C,nocc}$ is the fraction of the month which is the unoccupied (cooling) period (e.g. 10/31).

The input data shall be determined in accordance with 13.3.

For the simple hourly method and detailed simulation methods it is also permitted to directly take the unoccupied period into account in the calculation by adapting the occupancy input data for the unoccupied period.

13.3 Boundary conditions and input data

The values for the set-points may be determined at national level, depending on application and building type. In the absence of national values, the default values from Annex G may be used.

In the case of old existing buildings, if gathering the full required input would be too labour-intensive for the purpose, relative to the cost-effectiveness of gathering the input, a simplified method or default values, depending on system characteristics, may be defined at national level. Specification of the conditions for allowing this simple method/input may be made at national level, depending on the purpose of the calculation. In that case the user shall report which method/input has been used and from which source.

Details specifying when and how unoccupied periods can or shall be taken into account may be determined at national level, depending on application and building type.

14 Energy use for space heating and cooling

14.1 Annual energy needs for heating and cooling, per building zone

The annual energy needs for heating and cooling for the given building zones, $Q_{H,nd,an}$ and $Q_{C,nd,an}$, expressed in megajoules, are calculated as given by Equation (73), by summing the calculated energy need per period, taking into account possible weighting for different heating or cooling modes as defined in 13.2.2 and/or 13.2.4.

$$Q_{H,nd,an} = \sum_i Q_{H,nd,i} \quad \text{and} \quad Q_{C,nd,an} = \sum_j Q_{C,nd,j} \quad (73)$$

where

$Q_{H,nd,i}$ is the energy need for heating of the considered zone per calculation step (hour or month), determined in accordance with 7.2, expressed in megajoules;

$Q_{C,nd,j}$ is the energy need for cooling of the considered zone per calculation step (hour or month), determined in accordance with 7.2, expressed in megajoules.

The length of the heating and cooling season determining the operation period of certain system components is obtained from the respective subclauses in Clause 7.

14.2 Annual energy needs for heating and cooling, per combination of systems

In the case of a multi-zone calculation (with or without thermal interaction between zones), the annual energy needs for heating and cooling for a given combination of heating, cooling and ventilation systems servicing different zones, $Q_{H,nd,an,zs}$ and $Q_{C,nd,an,zs}$, expressed in megajoules, are calculated as the sum of the energy needs over the zones, z , that are serviced by the same combination of systems, as given by Equation (74):

$$Q_{H,nd,an,zs} = \sum_z Q_{H,nd,an,z} \quad \text{and} \quad Q_{C,nd,an,zs} = \sum_z Q_{C,nd,an,z} \quad (74)$$

where

$Q_{H,nd,an,z}$ is the annual energy need for heating of zone z , serviced by the same combination of systems, determined in accordance with 14.1, expressed in megajoules;

$Q_{C,n,an,z}$ is the annual energy need for cooling of zone z , serviced by the same combination of systems, determined in accordance with 14.1, expressed in megajoules.

14.3 Total system energy use for space heating and cooling and ventilation systems

14.3.1 General

In the case of a single combination of heating, cooling and ventilation systems in the building, or per combination of systems, the annual energy use for heating, $Q_{H,sys}$, and the annual energy use for cooling, $Q_{C,sys}$, including system losses, are determined as a function of the energy needs for heating and cooling from the relevant standards on heating and cooling systems as specified in Annex A. One may choose between the following three modes of presentation.

Option a):

Directly as total energy use of the system, $Q_{H,sys,i}$ and $Q_{C,sys,i}$ per energy carrier i , plus the auxiliary energy use, expressed in megajoules. The thermal losses are obtained by taking the difference between the energy needs for heating, $Q_{H,nd,i}$ and for cooling, $Q_{C,nd,i}$.

Option b):

As sum of energy needs for heating, $Q_{H,nd,i}$, heating system loss, $Q_{H,sys,ls,i}$ and auxiliary energy of the heating system, $Q_{H,sys,aux,i}$ per energy carrier i , expressed in megajoules. The thermal losses and auxiliary energy comprise generation, transport, control, distribution, storage and emission.

Similarly for cooling: $Q_{C,nd,i}$, $Q_{C,sys,ls,i}$ and $Q_{C,sys,aux,i}$.

Option c):

The system heat losses are indicated via an overall system efficiency. In this case, the conversion can be made as given by Equation (75):

$$Q_{H,sys} = \frac{Q_{H,nd}}{\eta_{H,sys}} \quad \text{and} \quad Q_{C,sys} = \frac{Q_{C,nd}}{\eta_{C,sys}} \quad (75)$$

where

$Q_{H/C,sys}$	is the energy use for the heating or cooling system including system losses, expressed in megajoules;
$Q_{H/C,nd}$	is the energy need for heating or cooling, serviced by the considered heating system, in accordance with 14.2, expressed in megajoules;
$\eta_{H/C,sys}$	is the overall system efficiency for the heating or cooling system, including generation, electronics, transport, storage, distribution and emission losses, except if reported separately as auxiliary energy.

These three options should lead to the same result and the choice is only a matter of convenience and/or convention. Option a) is however to be preferred, because it is the most straightforward route to the overall energy use.

Operation period auxiliary energy use:

It may be decided on a national basis to multiply the monthly auxiliary energy use for season-length-dependent provisions, such as pumps and controls, by respectively $f_{H,m}$ and $f_{C,m}$, the fraction of the month m that is part of the actual heating or cooling season for operation of season-length-dependent provisions, calculated in accordance with 7.4.

For the seasonal method, the monthly sum is replaced by the ratio of actual length of the heating or cooling season and the fixed length of the heating or cooling season, in accordance with 7.4.2.

14.3.2 Heating and cooling system thermal losses

The thermal losses by the heating and cooling systems shall preferably be given as total losses and as system thermal losses that are recovered in the system.

The system losses that are recovered in the building (as positive or negative heat gains from hot or cold sources) are already taken into account in the energy need for heating and cooling, unless the simplified alternative approach (see 10.4.5) is followed.

NOTE 1 In the case of more than one energy carrier it might not be evident what part of the energy used from the individual energy carrier is utilized and what part is lost.

NOTE 2 For buildings with co-generation, it is not straightforward how to determine the split between fuel used and heat produced, electricity produced and system loss. This split should nevertheless be performed as well as reasonably possible.

NOTE 3 System thermal losses for the cooling system can include heat dissipated from the indoor environment to the cold parts of the system (emission, storage, distribution, control) and/or heat dissipated to the hot parts of the system (generation, transport, electronics). Part of the heat dissipated to the cold parts of the system may be recovered in the building, as mentioned above.

The system losses also include the additional building heat loss due to non-uniform building zone temperature distribution and non-ideal building zone temperature control, if they are not already taken into account in the set-point temperature.

14.3.3 Thermal losses and energy use by ventilation system

The thermal losses and energy use by the ventilation system is to be determined in accordance with the relevant standard on ventilation systems as specified in Annex A. The following shall be taken into account.

The thermal losses in the ventilation system consist of the following:

- In the case of ventilation ducts: heat losses due to ventilation air leakage.

The heat losses due to ventilation duct air leakage shall be included, depending on the location of the ducts, either as recoverable thermal losses, added to the internal heat gains of the building or building zone, or as total losses and as system thermal losses that are recovered in the ventilation system.

- In the case of central pre-heating or pre-cooling.

- Annual energy use for central pre-heating of the supply air, $Q_{V,sys,pre-heat,an}$, expressed in megajoules, as given by Equation (76):

$$Q_{V,sys,pre-heat,an} = \sum_m (f_{H,m} Q_{V,nd,pre-heat,m} / \eta_{V,sys,pre-heat}) \quad (76)$$

where

$f_{H,m}$ is the fraction of the month m that is part of the actual heating season for operation of season-length-dependent provisions, calculated in accordance with 7.4;

$Q_{V,nd,pre-heat,m}$ is the energy need for pre-heating of the month m , calculated in accordance with 9.3.3.12, expressed in megajoules;

$\eta_{V,sys,pre-heat}$ is the overall system efficiency for the pre-heating system, including generation, electronics, transport, storage, distribution and emission losses, except if reported separately as auxiliary energy, to be determined in accordance with the relevant standard on heating or ventilation systems as specified in Annex A.

- Annual energy use for central pre-cooling of the supply air, $Q_{V,\text{sys,pre-cool,an}}$, expressed in megajoules, as given by Equation (77):

$$Q_{V,\text{sys,pre-cool,an}} = \sum_m (f_{C,m} Q_{V,\text{nd,pre-cool},m} / \eta_{V,\text{sys,pre-cool}}) \quad (77)$$

where

- $f_{C,m}$ is the fraction of the month m that is part of the actual cooling season for operation of season-length-dependent provisions, calculated in accordance with 7.4;
- $Q_{V,\text{nd,pre-cool},m}$ is the energy need for pre-cooling of the month m , calculated in accordance with 9.3.3.12, expressed in megajoules;
- $\eta_{V,\text{sys,pre-cool}}$ is the overall system efficiency for the pre-cooling system, including generation, electronics, transport, storage, distribution and emission losses, except if reported separately as auxiliary energy, to be determined in accordance with the relevant standard on cooling or ventilation systems as specified in Annex A.

For the seasonal method, the monthly sum is replaced by the ratio of actual length of the heating or cooling season and the fixed length of the heating or cooling season, in accordance with 7.4.2.

- Energy use for fans and controls:
 - energy use for fans;
 - energy use for de-frosting of heat recovery units.

Operation period:

In the case of season-length-dependent provisions, such as extra ventilation for free cooling or night-time ventilation during cooling mode, the monthly energy use shall be multiplied by $f_{H,m}$ or $f_{C,m}$, the fraction of the month m that is part of the actual heating or cooling season for operation of season-length-dependent provisions, calculated in accordance with 7.4.

For the seasonal method, the monthly sum is replaced by the ratio of actual length of the heating or cooling season and the fixed length of the heating or cooling season, in accordance with 7.4.2.

14.3.4 Results, per cluster of zones and for the whole building

It may be decided at national level how the results shall be presented, depending on the application.

Table 14 gives an example of how results can be presented in a way that is consistent with the requested input for EN 15315, for the purpose of energy certification of buildings.

If applicable, the table is repeated for different systems servicing different zones and summated for the different tables to obtain the values for the whole building.

The rows and columns in Table 14 need to be adapted for the building concerned. The columns include the relevant energy carriers. Separate tables shall be completed per cluster of zones in the case of different systems service, different (clusters of) zones.

In EN 15315, other energy usages, energy produced and exported and weighting factors are added to obtain the total overview. Consequently, a more detailed table may be provided, as suggested in EN 15315.

NOTE See also Figures K.1 to K.6 for an overview of all options related to energy use for heating and cooling.

Table 14 — Accounting energy uses, per combination of systems or whole building^a

Use of energy	Energy carrier								
	Heat	Oil ^b	Gas	Coal	District heating	District cooling	Wood	Electricity	Carrier <i>n</i>
Energy needs for heating									
Energy need for central pre-heating of ventilation air									
Heating system thermal losses									
Heating system energy use									
Auxiliary energy use for heating									
Energy needs for cooling									
Energy need for central pre-cooling of ventilation air									
Cooling system thermal losses									
Cooling system energy use									
Auxiliary energy use for cooling									
Energy use for ventilation (fans and controls)									
Ventilation system thermal losses for central pre-heating									
Ventilation system thermal losses for central pre-cooling									
Energy use for central pre-heating of ventilation air									
Energy use for central pre-cooling of ventilation air									
Sub-total									
Total									

This table contains the result for:

(fill in: zones Z or Y with same combination of systems, or sum for whole building)

Explanation:

 Blank cells: Input possible or required

 Grey cells: Not applicable

^a If applicable, this table shall be completed per cluster of zones that are serviced by the same combination of systems as distinguished in 14.2.

A similar table shall be completed for the whole building, summing the results of the clusters of zones.

^b Examples of energy carriers; to be adapted to the specific situation.

Extra attention shall be paid to:

- humidification and dehumidification: the system standards should give the combined sensible and latent heat, if applicable;
- correct book-keeping for system losses in the case of combined heating and DHW systems;
- application of renewable energy sources, production and export of energy, etc.; see Annex K; EN 15315 provides procedures for taking into account and reporting all energy flows in a coherent way;
- 14.3.5 for other special considerations.

14.3.5 Special considerations

Two or more heating systems servicing same zone(s)

In the case of absence in the relevant heating system standards in Annex A of a procedure on the combined effect of two or more heating generators servicing the same building zone(s) in an alternating mode, the energy need for heating the zone(s) are split into two parts as given by Equation (78):

$$Q_{H,nd,pref} = f_{pref} Q_{H,nd} \text{ and } Q_{H,nd,npref} = (1 - f_{pref}) Q_{H,nd} \quad (78)$$

where

$Q_{H,nd,pref}$ is part of the energy need for heating that is supplied by the preferentially operated heating appliance, expressed in megajoules;

$Q_{H,nd,npref}$ is part of the energy need for heating that is supplied by the non-preferentially operated heating appliance(s), expressed in megajoules;

f_{pref} is the year-averaged fraction of the total heat supply from the preferentially operated heating appliance, determined in accordance with national procedures taking into account the heating load of the building (zones) and the heating capacity of the preferentially operated heating appliance.

The system energy use shall be determined for $Q_{H,nd,pref}$ and $Q_{H,nd,npref}$ separately, attributing the associated heating systems.

NOTE Two or more heating generators are common practice, e.g. in the case of combined heat and power systems and heat pumps, where a secondary boiler with lower efficiency covers the peak loads; typical f_{pref} values range from 0 to 1 for heat pumps and from 0,15 to 0,60 for CHP.

15 Report

15.1 General

The main purpose of the report is to enable to trace or verify the input, assumptions and chosen methods.

A report giving an assessment of the annual heating and cooling energy use of a building obtained in accordance with this International Standard shall include at least the following information.

If the calculation is performed to check compliance with regulations, standardized input data provided by the regulations are used, and no error analysis is performed. Otherwise, an estimate of the accuracy of input data shall be given, and an error analysis shall be performed to estimate the uncertainty resulting from inaccuracy of the input data.

15.2 Input data

All input data shall be listed and justified, e.g. by reference to international or national standards, or by reference to the appropriate annexes to this International Standard or to other documents. When the input data are not the standard data, an estimate of the accuracy and source of input data shall also be given.

In addition, the report shall include:

- a) a reference to this International Standard, i.e. ISO 13790:2008;
- b) the purpose of the calculation (e.g. for judging compliance with regulations, optimizing energy performance, assessing the effects of possible energy conservation measures, or predicting energy resource needs on a given scale);

ISO 13790:2008(E)

- c) a description of the building, its construction and its location;
- d) a specification of the zone partitioning, if any, i.e. the allocation of rooms to each zone;
- e) a note indicating whether the dimensions used are internal, external or overall internal;
- f) a note indicating which method (detailed simulation, simple hourly, monthly or seasonal) was used and, if seasonal, the assumed fixed length of the heating and cooling season;
- g) a note on how thermal bridges have been taken into account;
- h) for the monthly, seasonal or simple hourly methods, H_{tr} , H_{ve} , A_s and C_m for each zone, for each month.

15.3 Results

15.3.1 For each building zone and each calculation period

15.3.1.1 For the monthly or seasonal method

- Monthly method: for each building zone and month, plus total per season
- Seasonal method: for each building zone and season

For heating mode:

- total heat transfer by transmission;
- total heat transfer by ventilation;
- total internal heat gains, including recoverable system thermal losses;
- total solar heat gains;
- energy need for heating;
- energy use for heating, per energy carrier;
- energy use by ventilation system (heating mode), per energy carrier.

For cooling mode:

- total heat transfer by transmission;
- total heat transfer by ventilation;
- total internal heat gains, including recoverable system thermal losses;
- total solar heat gains;
- energy need for cooling;
- energy use for cooling, per energy carrier;
- energy use by ventilation system (cooling mode), per energy carrier.

15.3.1.2 For simple hourly or detailed simulation methods

If the calculation (simple hourly or detailed method) uses dynamic (e.g. hourly) system properties, the energy needs should be calculated by assuming the ideal system (zero losses, perfect control) in a separate calculation.

For each building zone and month:

- total heat transfer by transmission and ventilation;
- total internal heat and solar gains including recoverable system thermal losses;
- energy need for heating;
- energy need for cooling;
- energy use for heating, per energy carrier;
- energy use for cooling, per energy carrier;
- energy use by ventilation system, per energy carrier.

Depending on the purpose of the calculation, it may be decided at national level to report, in parallel, the results from a monthly method as a first order check on the input and calculation process.

For detailed simulation methods the heat transfer and heat gains are difficult to separate.

A way of providing separate results is to perform three extra calculations (see References [13] and [23] in the Bibliography):

- Case 0: normal calculation to obtain $Q_{H,nd,0}$ and $Q_{C,nd,0}$.
- Case 1: as case 0, but zero internal and solar heat gains (including extra thermal radiation to sky), to obtain $Q_{H,nd,1}$ and $Q_{C,nd,1}$.
- Then as an approximation: $Q_{H,ht} = Q_{H,nd,1}$ and $Q_{C,ht} = Q_{C,nd,1}$.
- Case 2: as case 0, but a high set-point for heating and a low set-point for cooling, such that all heat gains are utilized in heating mode and all losses are utilized in cooling mode, to obtain $Q_{H,nd,2}$ and $Q_{C,nd,2}$.
- Case 3: as case 2, but with zero internal and solar heat gains (including extra thermal radiation to sky), to obtain $Q_{H,nd,3}$ and $Q_{C,nd,3}$.

Then as an approximation: $Q_{H,gn} = (Q_{H,nd,3} - Q_{H,nd,2})$ and $Q_{C,gn} = (Q_{C,nd,3} - Q_{C,nd,2})$.

NOTE This procedure may introduce some random and systematic deviations, but in the absence of a reliable alternative it could be the only robust check of the calculation input and process.

- a) Deviations might be introduced if (some of) the properties are a function of the local conditions.
- b) Deviations might occur due to, for example, heat sources that remain out of sight in the dynamic method; for instance, part of the solar or internal heat that is absorbed in the floor (wall or roof), goes to the ground (thence to the outside), without having been detected as contributing to the heat balance of the heated or cooled space.
- c) The result of steps 2 and/or 3 can be a small difference between two large and almost equal numbers and therefore subject to a large relative error.

15.3.2 For the whole building

In the case of a single-zone building, see 15.3.1 for the report per building zone.

For a single-zone or multi-zone building, provide the annual energy use for heating and cooling, plus the details as for instance given in Table 14.

NOTE 1 Guidance and comments on the accuracy of the calculation method are given in Annex H.

NOTE 2 Additional information can be required at national level.

Annex A (normative)

Parallel routes in normative references

This International Standard contains specific parallel routes in referencing other International Standards, in order to take into account existing national and/or regional regulations and/or legal environments while maintaining global relevance.

The standards that shall be used as called for in the successive clauses are given in Table A.1.

Table A.1 — Normative references

Clause	Subject	CEN area ^a	Elsewhere
3	Overall energy use, definitions	EN 15315	National standards or other appropriate documents
5.1	Energy balance of technical building systems	Heating: EN 15316-2.1, -2.3 Ventilation: EN 15241 Cooling: EN 15243	National standards or other appropriate documents
6.1	Energy performance rating	EN 15217	National standards or other appropriate documents
6.3	Influence of system boundaries on zoning rules	Heating: EN 15316-2.1, -2.3 Ventilation: EN 15241 Cooling: EN 15243	National standards or other appropriate documents
7.2.3	Validation of detailed simulation methods	EN 15265	National standards or other appropriate documents
8.3.2	Thermal transmission: — curtain walls — glazing — window frames — whole window or door	EN 13947 EN 673 ISO 10077-2 ISO 10077-1 Overall heat transfer by thermal transmission: ISO 13789 ^b See also note b.	National standards or other appropriate documents ISO 10292 ISO 10077-2 ISO 10077-1 ISO 15099 Overall heat transfer by thermal transmission: ISO 13789
9.3.1, 9.3.3	Ventilation air flows, time fractions and supply temperatures of air infiltration, natural ventilation and/or mechanical ventilation	EN 15242 and/or EN 15241	National standards or other appropriate documents Overall heat transfer by ventilation: ISO 13789

Table A.1 (continued)

Clause	Subject	CEN area ^a	Elsewhere
9.3.1, 9.3.3	Energy performance or supply temperature of heat recovery unit Supply temperature of central pre-heating and pre-cooling	If applicable: EN 15241 and subsequent EN standards Otherwise: national standards	National standards or other appropriate documents
10.4.3	Internal heat sources, contribution from lighting systems	EN 15193-1	National standards or other appropriate documents
10.4.4	Internal heat sources, contribution from hot water systems	EN 15316-3.1	National standards or other appropriate documents
10.4.5	Internal heat sources, contribution from heating, ventilation and cooling systems	If applicable: Heating: EN 15316-2.1, -2.3 Ventilation: EN 15241 Cooling: EN 15243 Otherwise: national standards	National standards or other appropriate documents (e.g. from ISO/TC 205)
11.4.2	Solar transmittance: — non-scattering glazings — windows with scattering glazing and/or solar shading devices	EN 410 For normal incidence angle: EN 13363-2 Otherwise: ISO 15099	ISO 9050 ISO 15099
13.1	Set-point temperature due to control systems: — heating — heating and/or cooling	EN 15316-2.1:2007, Clause 6.5.2 EN 15243:2007, Clause 14.3.2	National standards or other appropriate documents
14.3	Overall energy use, definitions, System losses and auxiliary energy use: — Heating system — Cooling system or combined heating and cooling system, including dehumidification — Ventilation system, including humidification — Energy use for ventilation air transport — Energy use for central pre-heating and/or pre-cooling	EN 15315 If applicable: EN 15316-2.1, -2.3 EN 15243 EN 15241 Otherwise: national standards If applicable: EN 15241 Otherwise: national standards EN 15316-2.1, -2.3 EN 15243	National standards or other appropriate documents
Annex E	Solar transmittance	See under 11.4.2 above	See under 11.4.2 above

^a CEN area: Countries whose national standards body is a member of CEN. Attention is drawn to the need for observance of EU Directives transposed into national legal requirements. Existing national regulations with or without reference to national standards can restrict, for the time being, the implementation of European Standards.

^b The thermal transmittance or *U*-value on the CE-marking, based on the product standard EN 14351-1 shall not be used. Quote from EN 14351-1:2005: "Where detailed calculation of the heat loss from a specific building is required, the manufacturer shall provide accurate and relevant, calculated or tested thermal transmittance values (design values) for the size(s) in question."

In the case of EN ISO standards, where there is a difference between the ISO and the EN ISO version, the EN ISO version shall be used within the CEN area.

Within the CEN area the following referenced documents are indispensable for the application of this document. For dated references, only the edition cited applies. For undated references, the latest edition of the referenced document (including any amendments) applies.

EN 410, *Glass in building — Determination of luminous and solar characteristics of glazing*

EN 673, *Glass in building — Determination of thermal transmittance [U value] — Calculation method*

EN 13363-2, *Solar protection devices combined with glazing — Calculation of total solar energy transmittance and light transmittance — Part 2: Detailed calculation method*

EN 13947, *Thermal performance of curtain walling — Calculation of thermal transmittance*

EN 15193-1, *Energy performance of buildings — Energy requirements for lighting — Part 1: Lighting energy estimation*¹⁾

EN 15217, *Energy performance of buildings — Methods for expressing energy performance and for energy certification of buildings*

EN 15241, *Ventilation for buildings — Calculation methods for energy losses due to ventilation and infiltration in commercial buildings*

EN 15242, *Ventilation for buildings — Calculation methods for the determination of air flow rates in buildings including infiltration*

EN 15243, *Ventilation for buildings — Calculation of room temperatures and of load and energy for buildings with room conditioning systems*

EN 15265, *Energy performance of buildings — Calculation of energy needs for space heating and cooling using dynamic methods — General criteria and validation procedures*

EN 15316-2-1, *Heating systems in buildings — Method for calculation of system energy requirements and system efficiencies — Part 2-1: Space heating emission systems*

EN 15316-2-3, *Heating systems in buildings — Method for calculation of system energy requirements and system efficiencies — Part 2-3: Space heating distribution systems*

EN 15316-3-1:2007, *Heating systems in buildings — Method for calculation of system energy requirements and system efficiencies — Part 3-1: Domestic hot water systems, characterization of needs (tapping requirements)*

For the CEN area, Figure A.1 gives an outline of the calculation procedure and its links with other EPBD-related standards.

1) To be published. (Revision of EN 15193-1:2004)

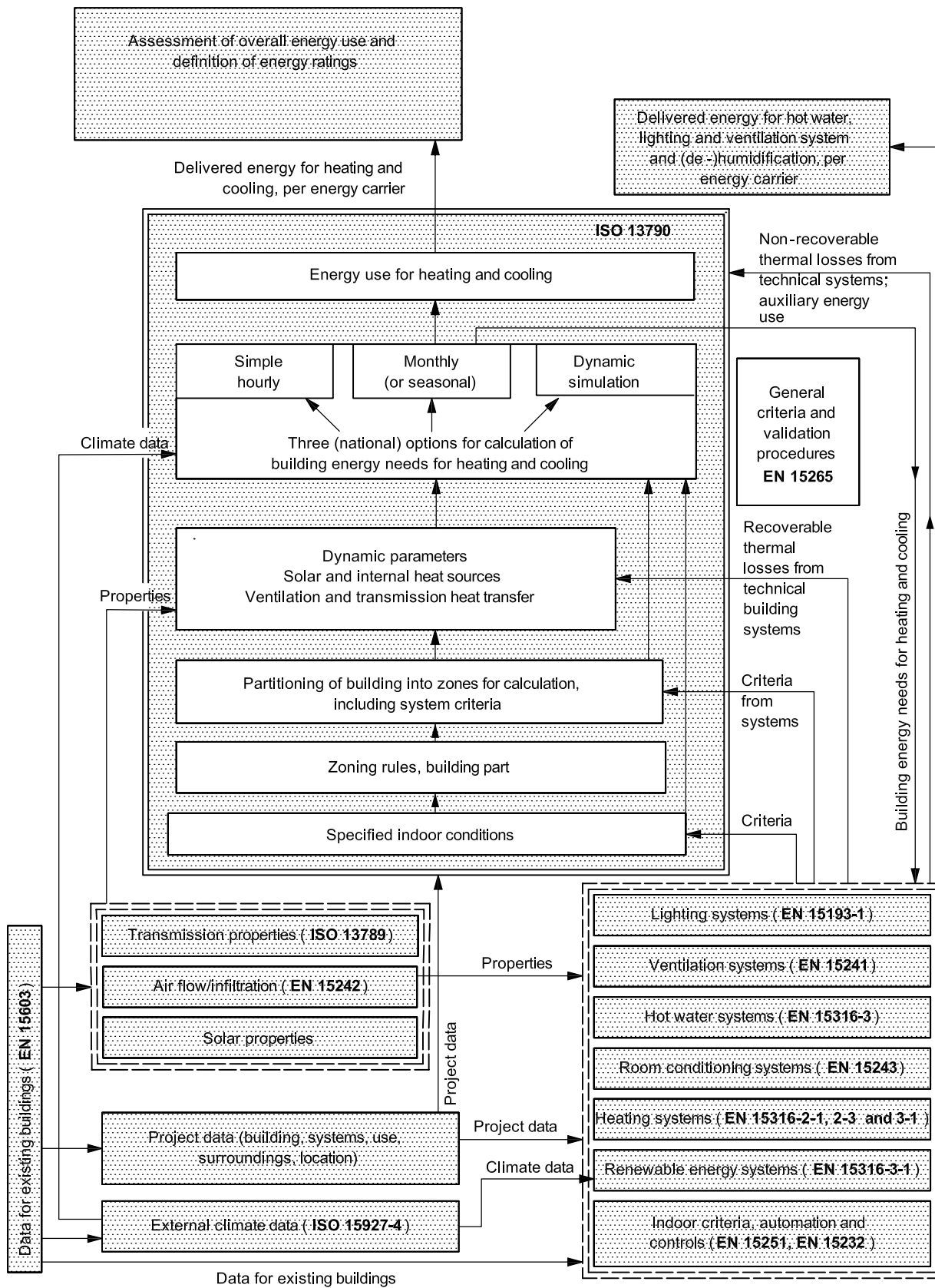

Figure A.1 — Flow chart of calculation procedure and links with other standards for the CEN area

Annex B (normative)

Multi-zone calculation with thermal coupling between zones

B.1 General

A multi-zone calculation with thermal coupling between zones (calculation with coupled zones) is only to be used with care for special situations.

A multi-zone calculation with interactions between the zones (a) requires significantly more and often arbitrary input data (on transmission properties and air flow direction and size) and (b) requires compliance with constraints in the building regulations on the zoning rules (freedom of internal partitioning, definitions of zoning in the case of combined use (e.g. a hospital generally also includes an office section, a restaurant section, etc.)). A further complication may be the involvement of different heating, cooling and ventilation systems for different zones, which adds to the complexity and arbitrariness of the input and modelling.

B.2 Simple hourly method

In the case of a multi-zone calculation with thermal coupling between zones (calculation with coupled zones) the RC network is modified as follows, depending on the heat exchanges taken into account.

1) Air flow exchanges

Air flow in one direction only:

In this case the air flow passes from thermal zone 1 to thermal zone 2. For a given hour, the calculation is done first for zone 1 and its air temperature is used to calculate the thermal behaviour of zone 2.

Air flow in both directions:

In this case, due, for example, to doors opening, zones 1 and 2 are considered as a single zone.

2) Heat flow through internal partitions

The aim is to take into account heat flows through walls and floors between adjacent zones. The boundary conditions are modified to calculate an equivalent H -value and external temperature. The boundary condition of each adjacent zone is the θ_{st} temperature node calculated at the previous hour.

NOTE 1 A physically meaningful dynamic coupling might not always be simple with the simple hourly method, e.g. in the case of two coupled zones separated by a heavyweight intermediate floor that contains most of the thermal mass

The RC network is modified as is shown in Figure B.1.

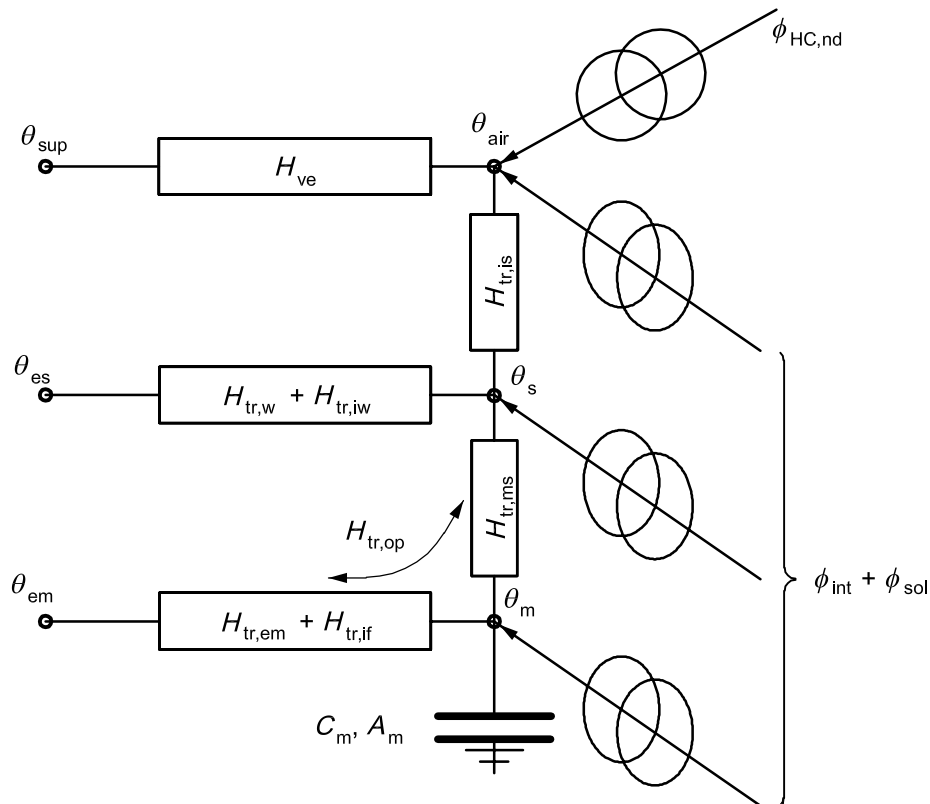

Figure B.1 — Modified RC network

$$\theta_{es} = \theta_e H_{tr,w} + \theta_{az} H_{iw} / (H_{tr,w} + H_{tr,iw})$$

$$\theta_{em} = \theta_e H_{tr,em} + \theta_{az} H_{if} / (H_{tr,em} + H_{tr,if})$$

where

θ_{az} is the internal temperature of the adjacent zone at the previous hour, expressed in degrees centigrade;

$H_{tr,iw}$ is the heat transfer through internal walls connected to the adjacent zone, determined in accordance with B.4, expressed in watts per kelvin;

$H_{tr,if}$ is the heat transfer through floors connected to the adjacent zone, determined in accordance with B.4, expressed in watts per kelvin.

The partitioning into thermally coupled zones and the input data shall be described in the report.

NOTE 2 In the case of strong thermal interactions between the zones, the method can lead to oscillations; in that case iteration is needed, using suitable relaxation factors.

B.3 Monthly method

In the case of a multi-zone calculation with thermal coupling between zones (calculation with coupled zones), the procedure, based on monthly calculation steps, is as follows.

In addition to the data needed for the single-zone or uncoupled-zone calculation, inter-zone data are collected, in accordance with B.4.

Add to the heat transfer, by transmission and ventilation of zone z , the following terms:

$$Q_{tr,z,y} = H_{tr,z,y}(\theta_{z,H/C} - \theta_{y,mn})t$$

$$Q_{ve,z \rightarrow y} = H_{ve,z \rightarrow y}(\theta_{z,H/C} - \theta_{y,mn})t$$

where $\theta_{y,mn}$ represents the actual mean temperature in an adjacent zone y , including any overheating (heating mode) or undercooling (cooling mode).

NOTE 1 It is important to note that, for zone y , the actual mean temperature is to be used. In zone z itself the set-point temperature $\theta_{z,H}$ for heating and $\theta_{z,C}$ for cooling is to be used. Taking the set-point temperature for zone y instead of the actual mean temperature would result in significant errors if there are strong interactions between the zones. In zone z itself, the actual mean temperature is not an input parameter in the calculation of the energy balance, but an implicit result of the utilization of heat gains or heat losses.

NOTE 2 These contributions to Q_{tr} and Q_{ve} also change the heat-balance ratio for heating and/or cooling mode.

The actual mean temperature in zone y is obtained using the following equations:

Heating mode:

$$\theta_{y,mn} = \frac{Q_{H,gn} + Q_{H,nd} + \sum_k (H_{H,ht,k} \theta_{a,k} / b_{tr,k})}{\sum_k (H_{H,ht,k} / b_{tr,k})} \quad (B.1)$$

Cooling mode:

$$\theta_{y,mn} = \frac{Q_{C,gn} - Q_{C,nd} + \sum_k (H_{C,ht,k} \theta_{a,k} / b_{tr,k})}{\sum_k (H_{C,ht,k} / b_{tr,k})} \quad (B.2)$$

where

$Q_{H,nd}$ is the building energy need for heating for zone y , determined in accordance with 7.2.1.1, expressed in megajoules;

$H_{H,ht,k}$ is the element k in the total heat transfer coefficient for the heating mode for zone y , adjusted for indoor-outdoor temperature difference, determined in accordance with 8.3, expressed in megajoules;

$b_{tr,k}$ is the adjustment factor, with value $b_{tr,k} \neq 1$ if the temperature at the other side of the construction element is not equal to the external environment, determined in accordance with 8.3;

$Q_{H,gn}$ represents the total heat gains for the heating mode for zone y , determined in accordance with 7.2.1.3, expressed in megajoules;

$Q_{C,nd}$ is the building energy need for cooling for zone y , determined in accordance with 7.2.1.2, expressed in megajoules;

$H_{C,ht,k}$ is the element k in the total heat transfer coefficient for the cooling mode for zone y , determined in accordance with 7.2.1.3, expressed in megajoules;

$Q_{C,gn}$ represents the total heat gains for the cooling mode for zone y , determined in accordance with 7.2.1.3, expressed in megajoules;

ISO 13790:2008(E)

$\theta_{a,k}$ for an element k of transmission heat transfer: the temperature at the other side of the element, $\theta_{e,k}$;

for an element k of ventilation heat transfer: the temperature of the air supply, $\theta_{a,sup,k}$.

NOTE 3 Dividing by the temperature adjustment factor is needed, because the heat transfer coefficients in these equations have to be the un-adjusted values.

NOTE 4 The same equation may be used for an unconditioned zone.

The calculation of the energy needs for heating and cooling shall be made in an iterative way (usually two or three steps suffice):

- 1) assume initially that the actual mean temperature in each zone is equal to the set-point temperatures for heating or cooling for that zone, determined in accordance with Clause 13;
- 2) calculate the energy needs for heating and cooling for each zone, taking into account the contribution of the heat transfer by transmission and/or ventilation between the zones, as described above;
- 3) on the basis of these results, calculate for each zone the actual mean temperature, as described above;
- 4) if the actual mean temperature of any of the zones differs by more than an acceptable minimum criterion (e.g. 0,3 °C), repeat from step 2); otherwise the iteration is completed successfully.

NOTE 5 This method is described (including computerized model and validation results), for the heating mode, in Reference [22].

The partitioning into thermally coupled zones and the input data shall be described in the report.

B.4 All methods: input data

The heat transfer coefficients between zones z and y are:

$H_{tr,z,y}$ is the transmission heat transfer coefficient between zones z and y , expressed in watts per kelvin;

$H_{ve,z \rightarrow y}$ is the ventilation heat transfer coefficient from zone z to zone y , expressed in watts per kelvin;

$H_{ve,y \rightarrow z}$ is the ventilation heat transfer coefficient from zone y to zone z , expressed in watts per kelvin.

where

$$H_{ve,z \rightarrow y} = \rho_a c_a q_{z \rightarrow y} \quad (\text{B.3})$$

$$H_{ve,y \rightarrow z} = \rho_a c_a q_{y \rightarrow z} \quad (\text{B.4})$$

$q_{z \rightarrow y}$ is the net air flow rate from zone z to zone y , expressed in cubic metres per second;

$q_{y \rightarrow z}$ is the net air flow rate from zone y to zone z , expressed in cubic metres per second.

NOTE The ventilation heat transfer coefficient $H_{ve,z \rightarrow y}$ differs from $H_{ve,y \rightarrow z}$ if the air flow rate is not the same in two directions.

Annex C (normative)

Full set of equations for simple hourly method

C.1 Introduction

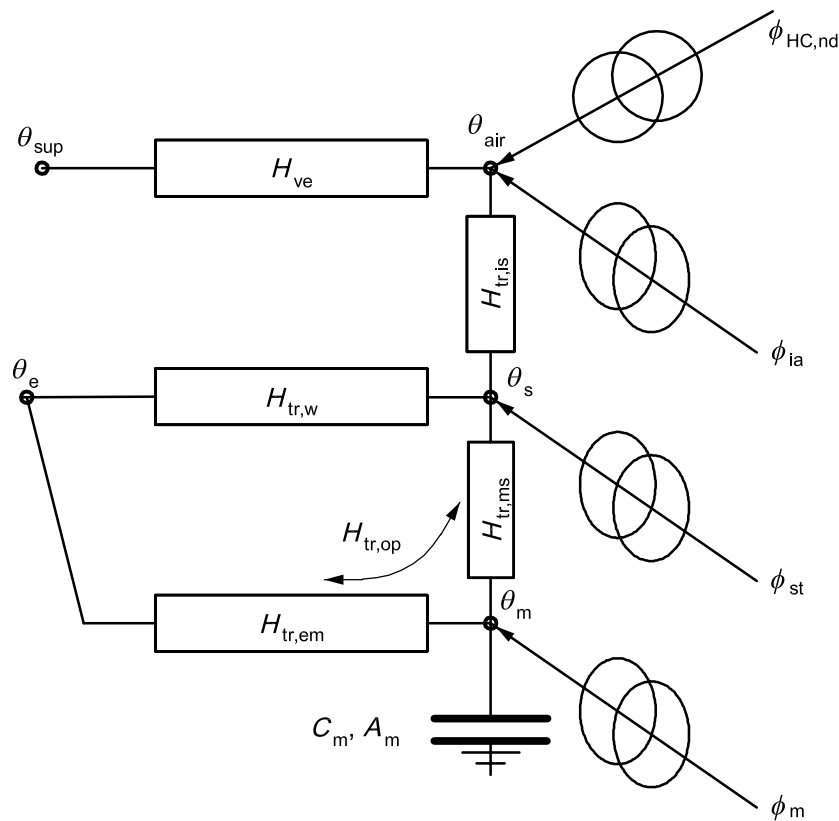

Figure C.1 — RC network heat flows

The general scheme and equations are presented in 7.2.2.

This annex describes the additional calculation procedure for calculating:

- the internal and solar heat gains to the internal nodes (see Clause C.2);
- the temperature nodes when $\Phi_{HC,nd}$ is known (see Clause C.3);
- the actual heating or cooling need, $\Phi_{HC,nd,ac}$, and the corresponding internal temperatures taking into account the possibility of imposing a maximum available heating or cooling power (C.4).

C.2 Calculation of heat flows from internal and solar heat sources

The heat flow rates from internal and solar heat sources Φ_{int} and Φ_{sol} , expressed in watts, are split between the air node, θ_{air} , and the internal nodes, $\theta_{\text{int}}, \theta_{\text{m}}$, as follows:

$$\Phi_{\text{ia}} = 0,5 \Phi_{\text{int}} \quad (\text{C.1})$$

$$\Phi_{\text{m}} = \frac{A_{\text{m}}}{A_{\text{t}}} (0,5 \Phi_{\text{int}} + \Phi_{\text{sol}}) \quad (\text{C.2})$$

$$\Phi_{\text{st}} = \left(1 - \frac{A_{\text{m}}}{A_{\text{t}}} - \frac{H_{\text{tr,w}}}{9,1 A_{\text{t}}} \right) (0,5 \Phi_{\text{int}} + \Phi_{\text{sol}}) \quad (\text{C.3})$$

The heat flow rates from internal and solar heat sources Φ_{int} and Φ_{sol} , expressed in watts, are derived by dividing Q_{int} and Q_{sol} , expressed in magajoules, by 0,036.

The heat flow rate from internal heat sources Φ_{int} is obtained from 10.2 and the heat flow rate from solar heat sources Φ_{sol} is obtained from 11.2.

A_{t} is obtained from 7.2.2.2 and A_{m} is obtained from 12.2.2.

C.3 Determination of the air and operative temperatures for a given value of $\Phi_{\text{HC,nd}}$

The solution model is based on a Crank-Nicholson scheme considering a time step of one hour. The temperatures are the average over one hour except for $\theta_{\text{m,t}}$ and $\theta_{\text{m,t-1}}$ which are instantaneous values at time t and $t-1$.

For a given time step, $\theta_{\text{m,t}}$, expressed in degrees centigrade, is calculated at the end of the time step from the previous value $\theta_{\text{m,t-1}}$ by:

$$\theta_{\text{m,t}} = \{ \theta_{\text{m,t-1}} [(C_{\text{m}}/3\ 600) - 0,5 \times (H_{\text{tr,3}} + H_{\text{tr,em}})] + \Phi_{\text{mtot}} \} / [(C_{\text{m}}/3\ 600) + 0,5 \times (H_{\text{tr,3}} + H_{\text{tr,em}})] \quad (\text{C.4})$$

with

$$\Phi_{\text{mtot}} = \Phi_{\text{m}} + H_{\text{tr,em}} \theta_{\text{e}} + H_{\text{tr,3}} \{ \Phi_{\text{st}} + H_{\text{tr,w}} \theta_{\text{e}} + H_{\text{tr,1}} \{ [(\Phi_{\text{ia}} + \Phi_{\text{HC,nd}})/H_{\text{ve}}] + \theta_{\text{sup}} \} \} / H_{\text{tr,2}} \quad (\text{C.5})$$

$$H_{\text{tr,1}} = \frac{1}{1/H_{\text{ve}} + 1/H_{\text{tr,is}}} \quad (\text{C.6})$$

$$H_{\text{tr,2}} = H_{\text{tr,1}} + H_{\text{tr,w}} \quad (\text{C.7})$$

$$H_{\text{tr,3}} = \frac{1}{1/H_{\text{tr,2}} + 1/H_{\text{tr,ms}}} \quad (\text{C.8})$$

$H_{\text{tr,em}}, H_{\text{tr,w}}, H_{\text{ve}}$, expressed in watts per kelvin, and $\theta_{\text{e}}, \theta_{\text{sup}}$, expressed in degrees centigrade, are obtained from Clauses 8 and 9.

C_{m} , expressed in joules per kelvin, is obtained from Clause 12.

For the considered time step, the average values of nodes temperatures are given by:

$$\theta_{\text{m}} = (\theta_{\text{m,t}} + \theta_{\text{m,t-1}}) / 2 \quad (\text{C.9})$$

$$\theta_{\text{s}} = \{ H_{\text{tr,ms}} \theta_{\text{m}} + \Phi_{\text{st}} + H_{\text{tr,w}} \theta_{\text{e}} + H_{\text{tr,1}} [\theta_{\text{sup}} + (\Phi_{\text{ia}} + \Phi_{\text{HC,nd}}) / H_{\text{ve}}] \} / (H_{\text{tr,ms}} + H_{\text{tr,w}} + H_{\text{tr,1}}) \quad (\text{C.10})$$

$H_{tr,ms}$, expressed in watts per kelvin, is obtained from 7.2.2.1.

$$\theta_{air} = (H_{tr,is} \theta_s + H_{ve} \theta_{sup} + \Phi_{ia} + \Phi_{HC,nd}) / (H_{tr,is} + H_{ve}) \quad (C.11)$$

and the operative temperature by

$$\theta_{op} = 0,3 \times \theta_{air} + 0,7 \times \theta_s \quad (C.12)$$

NOTE This is an approximation. The operative temperature is a weighted average of the air and mean radiant temperatures, weighted by the internal surface convective (3/8) and radiative coefficients (5/8). The value of θ_s is a mix between air and mean radiant temperature.

C.4 Calculation of internal temperature and required heating or cooling power

C.4.1 General description

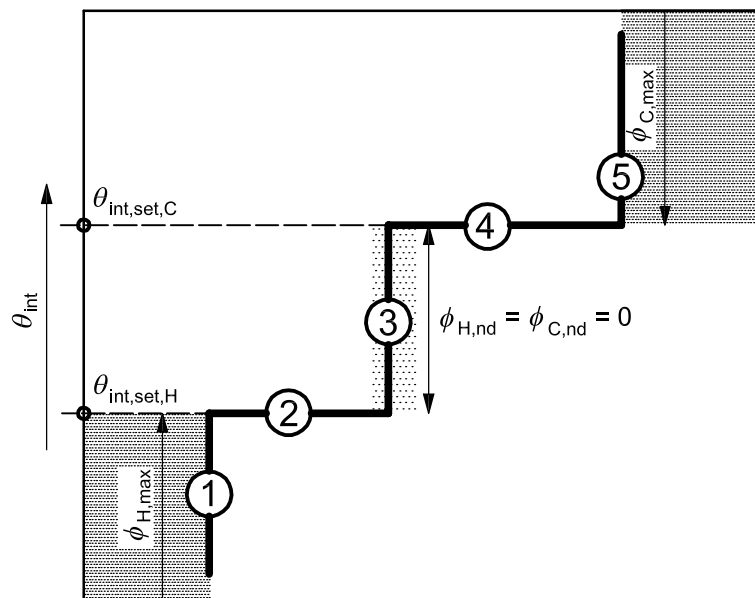

Key

Symbols: see text

1-5 building zone temperature behaviour, referring to the five situations described in the text

Figure C.2 — Building zone temperature behaviour versus system behaviour

For each hour, the RC network enables the calculation of the internal temperature for any amount of heating or cooling need, $\Phi_{HC,nd}$. The resolution scheme is such that the internal temperature is determined as a linear function of $\Phi_{HC,nd}$.

For a given hour, the building zone behaviour line is known by applying equations described in Clause C.3 for two values of $\Phi_{HC,nd}$.

ISO 13790:2008(E)

The heating and cooling power delivered to the building zone can be represented on the same graph by the $\theta_{\text{int,H,set}}$ and $\theta_{\text{int,C,set}}$ temperatures and the maximum available heating and cooling power (which can vary for each hour²⁾).

The resulting indoor temperature and heating and cooling needs are derived from the intersection of the two curves.

Five situations can occur:

- 1) The building zone requires heating and the heating power is not sufficient to obtain the set-point. The heating need is limited to the maximum available heating power and the calculated internal temperature is lower than the heating set-point $\theta_{\text{int,H,set}}$. This usually happens in the boost period.
- 2) The building zone requires heating and the heating power is sufficient. The internal temperature is equal to $\theta_{\text{int,H,set}}$ and the calculated heating need is lower than its maximum value.
- 3) The building zone requires neither heating nor cooling (free floating conditions). No heating or cooling is applied, and the internal temperature is calculated.
- 4) The building zone requires cooling and the cooling power is sufficient. The internal temperature is equal to $\theta_{\text{int,C,set}}$ and the calculated cooling need is lower than its maximum value.
- 5) The building zone requires cooling and the cooling power is not sufficient. The cooling need is limited to the maximum available cooling power. The calculated internal temperature is higher than the cooling set-point $\theta_{\text{int,C,set}}$.

C.4.2 Calculation procedure

The procedure in this subclause is based on the air temperature, θ_{air} , as set-point temperature. To use the operative temperature as set-point, the operative temperature shall be calculated (see Equation C.11) and the procedure given in this subclause shall be adapted accordingly.

The procedure calculates the actual internal temperature, $\theta_{\text{air,ac}}$, and the actual heating or cooling power, $\Phi_{\text{HC,nd,ac}}$. In all cases, the value of $\theta_{\text{m,t}}$ [see Equation (C.8)] is also calculated and stored, as it is used for the following time step.

Step 1: Check if cooling or heating is needed (case 3 of Figure C.2).

Take $\Phi_{\text{HC,nd}} = 0$ and apply Equations (C.7) to (C.11).

Name the resulting θ_{air} as $\theta_{\text{air,0}}$ ($\theta_{\text{air,0}}$ is the air temperature in free floating conditions).

If $\theta_{\text{int,H,set}} \leq \theta_{\text{air,0}} \leq \theta_{\text{int,C,set}}$, no heating or cooling is required so that $\Phi_{\text{HC,nd,ac}} = 0$ and $\theta_{\text{air,ac}} = \theta_{\text{air,0}}$, and no further calculations are needed.

If not: apply step 2.

Step 2: Choose the set-point and calculate the heating or cooling need.

If $\theta_{\text{air,0}} > \theta_{\text{int,C,set}}$, take $\theta_{\text{air,set}} = \theta_{\text{int,C,set}}$

If $\theta_{\text{air,0}} < \theta_{\text{int,H,set}}$, take $\theta_{\text{air,set}} = \theta_{\text{int,H,set}}$

NOTE 1 Conditions might have to be added to separate the set-pos (hysteresis), to prevent oscillations.

2) The scheme could be modified to take into account a maximum heating or cooling power depending on internal temperature.

Apply Equations (C.7) to (C.11) taking $\Phi_{\text{HC,nd}} = \Phi_{\text{HC,nd10}}$ with $\Phi_{\text{HC,nd10}} = 10 A_f$.

A_f is obtained from 6.3.2.

Name the resulting θ_{air} as θ_{air10} (θ_{air10} is the air temperature obtained for a heating power of 10 W/m²).

Calculate $\Phi_{\text{HC,nd,un}}$ (unrestricted heating or cooling need to reach the required set-point temperature; $\Phi_{\text{HC,nd,un}}$ is positive for heating and negative for cooling).

$$\Phi_{\text{HC,nd,un}} = \Phi_{\text{HC,nd10}} (\theta_{\text{air,set}} - \theta_{\text{air,0}}) / (\theta_{\text{air,10}} - \theta_{\text{air,0}}) \quad (\text{C.13})$$

Step 3: Check if the available cooling or heating power is sufficient (case 2 or case 4 of Figure C.2).

If $\Phi_{\text{HC,nd,un}}$ is between $\Phi_{\text{H,max}}$ (maximum heating power) and $\Phi_{\text{C,max}}$ (maximum cooling power):

$$\Phi_{\text{HC,nd,ac}} = \Phi_{\text{HC,nd,un}}$$

$$\theta_{\text{air,ac}} = \theta_{\text{air,set}}$$

and the calculation is completed.

If not: apply step 4.

Step 4: Calculate the internal temperature (case 1 or case 5 of Figure C.2).

If $\Phi_{\text{HC,nd,un}}$ is positive, take $\Phi_{\text{HC,nd,ac}} = \Phi_{\text{H,max}}$. If $\Phi_{\text{HC,nd,un}}$ is negative, take $\Phi_{\text{HC,nd,ac}} = \Phi_{\text{C,max}}$.

Calculate $\theta_{\text{air,ac}}$ by using Equations (C.5) to (C.9).

NOTE 2 In this case, the set-point temperature is not attained.

The energy need for heating or cooling for a given hour, $Q_{\text{HC,nd}}$, expressed in megajoules, is equal to $0,036 \times \Phi_{\text{HC,nd,ac}}$. The value is positive in the case of heating need and negative in the case of cooling need.

Annex D (normative)

Alternative formulation for monthly cooling method

D.1 Introduction

Instead of the formulation for the monthly cooling method based on the loss utilization factor, an alternative formulation may be used, based on the gain utilization factor. The two formulations are identical, provided that the parameter values are the same and the same quantities are used for the total heat gains and total heat losses that determine the heat-balance ratio.

The difference between the two formulations is that the formulation based on the loss utilization factor allows “negative” heat losses. Negative heat losses can occur if for (parts of) the transmission, the monthly average external temperature or adjacent building zone temperature, and/or for ventilation losses, the supply temperature, exceeds the building zone temperature.

NOTE The formulation based on loss utilization factor has as additional an advantage in that it shows explicitly how the heat losses contribute to the reduction of the energy need for cooling.

D.2 Alternative formulation for energy need for cooling

As introduced in 5.4.2, Equation (4) to determine the cooling need, $Q_{C,nd}$, expressed in megajoules, can be reformulated to obtain the following equation:

$$Q_{C,nd} = (1 - \eta_{C,gn})Q_{C,gn} \quad (D.1)$$

subject to $Q_{C,nd}$ being equal to or greater than 0 and where (for each building zone and for each month)

$Q_{C,ht}$ is the heat transfer for the cooling mode, determined in accordance with 7.2.1.3, expressed in megajoules;

$Q_{C,gn}$ represent the heat gains for the cooling mode, determined in accordance with 7.2.1.3, expressed in megajoules;

$\eta_{C,gn}$ is the dimensionless gain utilization factor for the cooling mode, determined in accordance with D.2.

NOTE 1 If the same input and the same parameter values are used, Equation (D.1) leads to the same results as Equation (4).

NOTE 2 $Q_{C,ht}$ does not appear directly in the equation, but indirectly via $\eta_{C,gn}$.

NOTE 3 The gain utilization factor, $\eta_{C,gn}$, has been introduced in 5.4.2 (cooling, method b). The curves are similar to the curves for the gain utilization curves for the heating mode; see illustration in Figure D.1. In Clause D.4 it is shown how $\eta_{C,gn}$ can be derived from $\eta_{C,ls}$ by a simple conversion formula and vice versa.

D.3 Length of cooling season

See 7.4.1.

D.4 Gain utilization factor for cooling

The gain utilization factor needed for the alternative formulation of the monthly cooling method in accordance with clause D.2 is determined analogous to the gain utilization factor for heating in 12.2.1.1, by replacing “heating” by “cooling” and subscript H by subscript C, with the following changes:

$a_{C,0}$ is a dimensionless reference numerical parameter, determined in accordance with Table 10 in 12.2.1.2;

$\tau_{C,0}$ is a reference time constant, determined in accordance with Table 10 in 12.2.1.2.

NOTE 1 The equation does not provide values for the gain utilization factor, $\eta_{C,gn}$, if the heat-balance ratio is negative, which can occur if the losses include parts with high internal, adjacent and/or supply temperature. The method in 7.2.1 has no such limitation.

NOTE 2 The gain utilization factor, $\eta_{C,gn}$, has been introduced in 5.4.2 (cooling, method b). The curves are similar to the curves for the gain utilization curves for the heating mode.

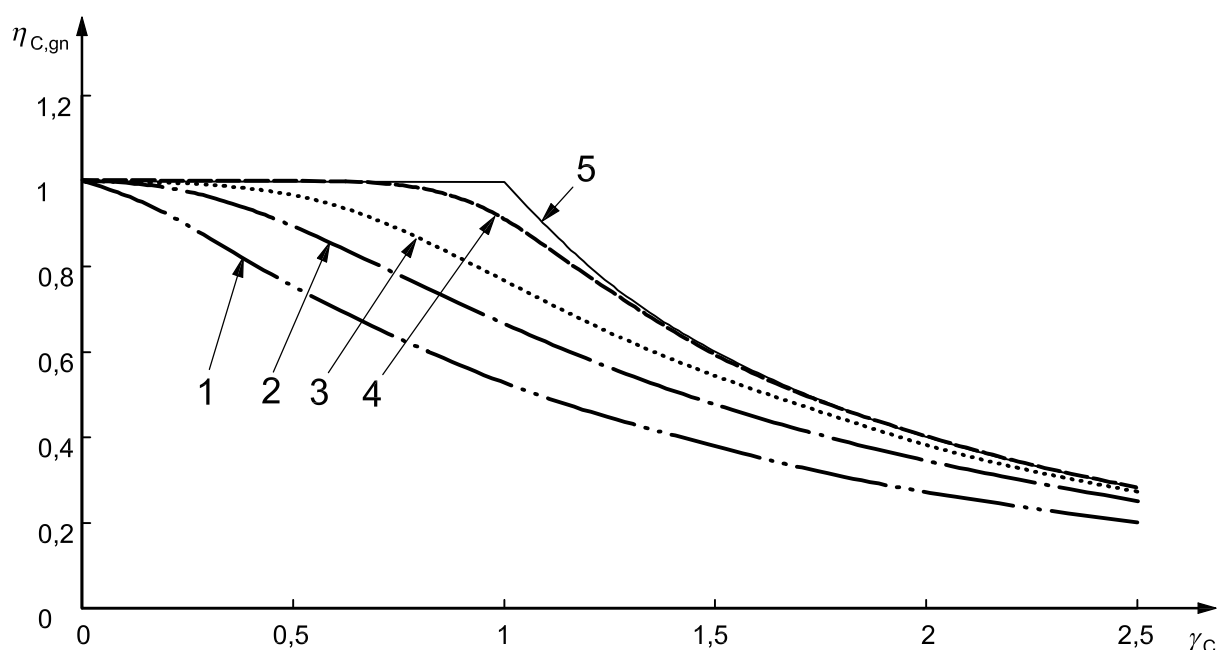

Key

- 1 time constant of 8 h (low inertia)
- 2 time constant of 1 d
- 3 time constant of 2 d
- 4 time constant of 7 d
- 5 time constant infinite (high inertia)

Figure D.1 — Examples of gain utilization curves for cooling (alternative formulation)

Provided that the same parameter values (a_C and τ) are used, a simple formula converts between the two formulations for the cooling mode:

$$\eta_{C,gn} = \eta_{C,ls} / \gamma_{C,ls} \quad (D.2)$$

NOTE See also 7.2.1.3: if the clustering of heat gains in Q_{gn} and heat transfer elements in Q_{ht} is different from the clustering in 7.2.1.3, the heat-balance ratio will be different; consequently the calculated energy need for cooling will also differ, although the difference can be small.

Annex E (normative)

Heat transfer and solar heat gains of special elements

E.1 Scope

This annex provides the procedures to calculate the heat transfer and solar heat gains of special elements, such as (unconditioned) sunspaces, opaque elements with transparent insulation, ventilated solar walls and ventilated envelope elements.

E.2 Unconditioned sunspaces

E.2.1 General

The following applies to unconditioned sunspaces adjacent to a conditioned space, such as conservatories and attached greenhouses separated by a partition wall from the conditioned space.

If the sunspace is heated, or if there is a permanent opening between the conditioned space and the sunspace, it shall be considered as part of the conditioned space, and the calculation procedures given in E.2.2 and E.2.3 or E.2.4 do not apply. In that case, the area to be taken into account for the heat transfer and solar heat gains is the area of the external envelope of the sunspace.

In the case of old existing buildings, if gathering the full required input would be too labour-intensive for the purpose, relative to the cost-effectiveness of gathering the input, a simplified method or default values, depending on the characteristics of the unconditioned sunspace, may be defined at national level, as an alternative for the calculation procedures given in E.2.2 and E.2.3 or E.2.4. Specification of the conditions for allowing this simple method or input may be made at national level, depending on the purpose of the calculation. In that case the user shall report which method or input has been used and from which source.

E.2.2 Heat transfer

The heat transfer by transmission and ventilation is calculated in accordance with Clauses 8 and 9 for the partition wall between a conditioned zone and an adjacent unconditioned space, using the adjustment factor b_{tr} , in accordance with ISO 13789.

E.2.3 Solar heat gains

E.2.3.1 General

The solar heat gains entering the conditioned space from the sunspace are the sum of direct solar heat gains, via the sunspace through the partition wall and indirect heat gains through the partition wall from the sunspace heated by the sun.

The calculation method quantifies the positive effect during the heating season. However, the same procedure shall also be used to calculate the solar gains for the cooling (summer) mode, taking into account any extra (seasonal) solar protection and ventilation provisions, if present.

E.2.3.3 Calculation method

The solar heat gains entering the conditioned space from the sunspace, Q_{ss} , expressed in megajoules, are the sum of direct heat gains through the partition wall, Q_{sd} , and indirect heat gains, Q_{si} , from the sunspace heated by the sun:

$$Q_{ss} = Q_{sd} + Q_{si} \quad (E.1)$$

It is assumed, in a first approximation, that the absorbing surfaces are all shaded in the same proportion by external obstacles and by the outer envelope of the sunspace.

The direct solar heat gains, Q_{sd} , expressed in megajoules, are the sum of heat gains through the transparent (subscript w) and opaque (subscript p) parts of the partition wall:

$$Q_{sd} = F_{sh,e} (1 - F_{F,e}) g_e \left((1 - F_{F,w}) g_w A_w + \alpha_p A_p \frac{H_{p,tot}}{H_{p,e}} \right) I_p t \quad (E.2)$$

The indirect heat gains are calculated by summing the solar heat gains of each absorbing area, j , in the sunspace, but deducting the direct heat gains through the opaque part of the partition wall:

$$Q_{si} = (1 - b_{tr}) F_{sh,e} (1 - F_{F,e}) g_e \sum_j (I_j a_j A_j) - F_{sh,e} (1 - F_{F,e}) g_e \alpha_p A_p \frac{H_{p,tot}}{H_{p,e}} I_p t \quad (E.3)$$

The adjustment factor, b_{tr} , is the same as mentioned in E.2.1. The weighting factor $(1 - b_{tr})$ is that part of the solar heat gains to the sunspace which enters the conditioned space through the partition wall. This term is obtained from 11.2.

E.2.3.4 Conservative approximation

The following procedure may be used as a conservative approximation of the procedure in E.2.3.2 and E.2.3.3.

In the calculation of the energy balance of the calculation zone adjacent to the sunspace for the heating mode:

- calculate the heat transfer by transmission using the adjustment factor, b_{tr} , as for an unconditioned adjacent space;
- ignore the additional (indirect) gains via the sunspace into the calculation zone;
- calculate only the direct solar transmittance through the partition wall, taking into account the reduced solar transmittance by the sunspace envelope.

In the calculation of the energy balance of the calculation zone adjacent to the sunspace for the cooling mode:

- calculate the heat transfer by transmission using the adjustment factor, b_{tr} , as for an unconditioned adjacent space;
- ignore the sunspace for the calculation of the solar heat gains into the calculation zone;
- do not take into account any reduction of the solar energy transmittance by the sunspace envelope, except for solar shading provisions that are permanently applied during the whole cooling season.

NOTE It is checked at national level whether this procedure is adequately conservative.

E.2.4 Simplified method

It may be decided at national level, depending on the application and type of building, to use the following simplified procedure, as an alternative to the procedure in E.2.3.2 and E.2.3.3.

This procedure is based on the normative Annex A of ISO 13789:2007.

In the calculation of the energy balance of the calculation zone adjacent to the sunspace:

- ignore the (internal and) solar gains in and through the sunspace;
- specify a corrected value for the adjustment factor b_{tr} , to be applied for the heating mode, that includes the beneficial effect of the (internal and) solar gains during the heating season; this value may depend on the type and/or size of the sunspace;
- specify an appropriate corrected value for the adjustment factor b_{tr} , to be applied for the cooling mode, that includes the negative effect of the (internal and) solar gains during the cooling season.

NOTE This implies that the (internal and) solar gains shall not again be taken into account in 10.2 and 11.2, which is clearly stated there.

E.3 Opaque elements with transparent insulation

E.3.1 Heat transfer

For the calculation of the heat transfer, opaque elements with transparent insulation shall be treated as opaque construction elements.

E.3.2 Solar heat gains

E.3.2.1 General

The following applies to opaque building elements provided with transparent insulation material, designed to collect solar energy. The calculation method quantifies the positive effect during the heating season. However, the same procedure shall also be used to calculate the solar gains for the cooling (summer) mode, taking into account any extra (seasonal) solar protection and ventilation provisions, if present.

E.3.2.2 Required input data

A	total area of the element;
A_t	area of the element covered with transparent insulation;
R_i	thermal resistance of the opaque element behind transparent insulation;
R_t	thermal resistance of transparent insulation;
$g_{t,\perp}$	total solar energy transmittance of transparent insulation (normal incidence);
$g_{t,hem}$	total solar energy transmittance of transparent insulation (diffuse-hemispherical incidence);
R_{al}	thermal resistance of the air layer (enclosed) between the opaque element and transparent insulation;
R_{si}	internal thermal surface resistance;
R_{se}	external thermal surface resistance;
F_{sh}	shading correction factor.

ISO 13790:2008(E)

Depending on the type of transparent insulation, the following quantity is required (it is not required for products that include a solar absorber):

α absorptance of the opaque element behind transparent insulation.

E.3.2.3 Derived properties

U thermal transmittance of the element, from environment to environment;

U_{te} external thermal transmittance of the element, from the surface facing the transparent insulation product to the external environment;

g_t effective total solar energy transmittance of the transparent insulation product;

F_F reduction factor due to non-transparent frame area of the transparent insulation (frame area fraction).

E.3.2.4 Calculation method

The heat transfer is calculated in accordance with Clause 8, as for usual envelope elements, including possible thermal bridges in framed constructions. The solar heat gains of an opaque element with transparent insulation, having the orientation j , are calculated for month m in accordance with 11.2 using an effective collecting area.

The frame area fraction is determined from the total area, A , of the element:

$$F_F = \frac{A_t}{A} \quad (\text{E.4})$$

The following thermal transmittances are needed for the efficiency factor to be calculated:

$$U_{te} = \frac{1}{R_{se} + R_t + R_{al}} \quad (\text{E.5})$$

$$U = \frac{1}{R_{se} + R_t + R_{al} + R_i + R_{si}}$$

The calculation of the effective total solar energy transmittance depends on the type of the transparent insulation. It takes into account the angle of incidence of direct solar radiation, using the coefficients $c_{j,m}$ of Table E.1.

For products with non-negligible solar energy transmittance, the effective value is proportional to the absorptance of the opaque element behind transparent insulation:

$$g_{t,j,m} = \alpha (g_{t,hem} - c_{j,m} g_{t,\perp}) \quad (\text{E.6})$$

For transparent insulation with negligible solar transmittance (e.g. products with solar absorber included), the value determined from measurements shall only be modified to take account of the thermal resistance, R_g , of the air gap between the transparent insulation and the opaque element:

$$g_{Tl,j,m} = \frac{R_{se} + R_t}{R_{se} + R_t + R_g} (g_{t,h} - c_{j,m} g_{t,\perp}) \quad (\text{E.7})$$

The effective collecting area for orientation j and month m is:

$$A_{sol,j,m} = A F_{sh} (1 - F_F) \frac{U}{U_{te}} g_{t,j,m} \quad (\text{E.8})$$

The heat gains are added to the other solar heat gains.

Table E.1 — Coefficients $c_{j,m}$ for calculation of the effective total solar energy transmittance of transparent insulation using the measured values for normal and hemispherical incidence (for vertical walls)

	Jan.	Feb.	Mar.	Apr.	May	June	July	Aug.	Sept.	Oct.	Nov.	Dec.
S	−0,105	−0,067	−0,023	0,042	0,073	0,089	0,094	0,062	0,005	−0,054	−0,093	−0,105
SW/SE	−0,034	−0,027	−0,010	0,002	0,022	0,037	0,036	0,013	−0,015	−0,025	−0,034	−0,026
W/E	0,054	0,033	0,016	−0,012	−0,005	−0,002	−0,012	−0,007	−0,001	0,024	0,049	0,052
NE/NW	0,002	0,008	0,016	0,030	0,018	0,013	0,013	0,024	0,033	0,014	0,004	0,000
N	0,000	0,000	0,000	0,011	0,021	0,031	0,042	0,012	0,000	0,000	0,000	0,000

E.4 Ventilated solar walls (Trombe walls)

E.4.1 Heat transfer

E.4.1.1 General

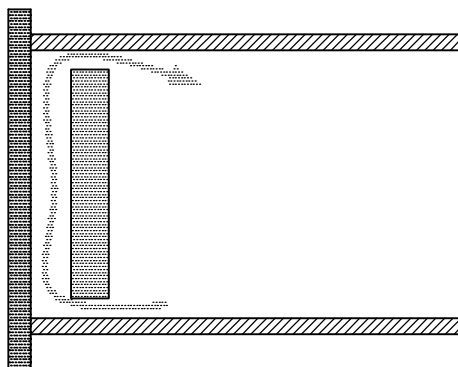

Figure E.2 — Air flow path in a ventilated solar wall

The following applies to walls designed to collect solar energy, in accordance with Figure E.2, where

- the air flow is stopped automatically when the air layer is colder than the heated space and during summer,
- the air flow rate is set mechanically at a constant value, $q_{ve,sw}$, when the air layer is warmer than the heated space.

The heat transfer coefficient of such a wall is:

$$H = H_0 + \Delta H \quad (\text{E.9})$$

where

H_0 is the heat transfer coefficient of the non-ventilated wall;

ΔH is an additional heat transfer coefficient to be calculated in accordance with E.4.1.3.

ISO 13790:2008(E)

E.4.1.2 Required data

A_{sw} area of the ventilated solar wall;

R_i internal thermal resistance of the wall, between the air layer and the internal environment;

R_e external thermal resistance of the wall, between the air layer and the external environment;

R_l thermal resistance of the air layer;

$q_{ve,sw}$ set value of the air flow rate through the ventilated layer;

h_c convective surface heat transfer coefficient in the air layer;

h_r radiative surface heat transfer coefficient in the air layer;

$Q_{gn,sw}$ solar heat gains of the air layer during the calculation step: $Q_{gn,sw} = I_w A_{sw}$

$Q_{ht,al}$ heat loss of the air layer during the calculation step: $Q_{ht,al} = U_e A_{sw} (\theta_{int} - \theta_e) t$

E.4.1.3 Calculation method

The additional heat transfer coefficient of such a wall is calculated by:

$$\Delta H = \rho_a c_a q_{ve,sw} \left[\frac{U_e}{U_i} \right]^2 \delta \kappa_{sw} \quad (E.10)$$

where

$\rho_a c_a$ is the heat capacity of air per volume;

U_i and U_e are the internal and external thermal transmittances:

$$U_i = \frac{1}{R_i + \frac{R_l}{2}} \quad \text{and} \quad U_e = \frac{1}{R_e + \frac{R_l}{2}} \quad (E.11)$$

δ is the ratio of the accumulated internal-external temperature difference when the ventilation is on, to its value over the whole calculation step. It is given in Figure E.3.

This ratio can be calculated by:

$$\delta = 0,3\gamma_{al} + 0,03(0,0003^{\gamma_{al}} - 1) \quad (E.12)$$

where γ_{al} is the ratio of the solar heat gains, $Q_{gn,sw}$, to the heat loss of the air layer, $Q_{ht,al}$, during the calculation step.

K_{sw} is a factor defined by:

$$K_{sw} = \left[1 - \exp\left(\frac{-A_{sw}Z}{\rho_a c_a q_{ve,sw}}\right) \right] \quad (E.13)$$

where Z is a parameter defined by:

$$\frac{1}{Z} = \frac{h_r}{h_c(h_c + 2h_r)} + \frac{1}{U_i + U_e} \quad (\text{E.14})$$

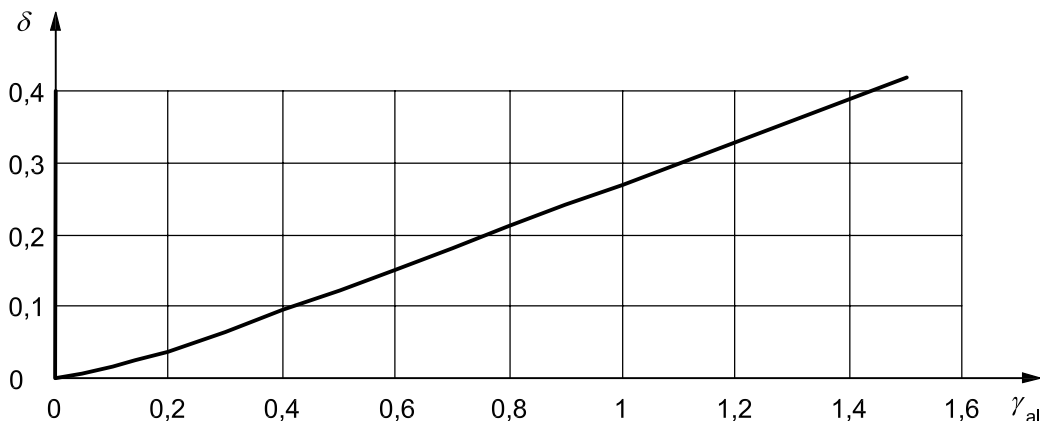

Figure E.3 — Ratio δ of the accumulated internal-external temperature difference when the ventilation is on, to its value over the whole calculation step, as a function of the gain/load ratio of the air layer, γ_{al}

E.4.2 Solar heat gains

E.4.2.1 General

The following applies to ventilated solar walls, designed to collect solar energy. The calculation method quantifies the positive effect during the heating season. However, the same procedure shall also be used to calculate the solar gains for the cooling (summer) mode, taking into account any extra (seasonal) solar protection and ventilation provisions, if present.

E.4.2.2 Required data

The following applies to ventilated solar walls.

In addition to data listed in E.4.1, the following input data are needed:

- F_F frame area fraction;
- F_{sh} shading reduction factor, calculated in accordance with 11.4.3;
- α absorption coefficient of the surface behind the air layer;
- g total solar energy transmittance of the glazing covering the air layer.

E.4.2.3 Calculation method

Solar heat gains are calculated in accordance with 11.2 using an effective collecting area.

a) If the ventilated layer is covered by an opaque external layer:

$$A_{sol} = A_{sw} \alpha F_{sh} (1 - F_F) \frac{U_0}{h_e} \left[1 + \frac{U_0}{U_i^2} \rho_a c_a \frac{q_{ve,sw}}{A_{sw}} \kappa_{sw} \omega \right] \quad (\text{E.15})$$

where

U_i and κ_{sw} are calculated in accordance with E.4.1;

ω is the ratio of the total solar radiation falling on the element when the air layer is open to the total solar radiation during the whole calculation step; ω is given in Figure E.4. It can be calculated by:

$$\omega = 1 - \exp(-2,2\gamma_{al}) \quad (\text{E.16})$$

where γ_{al} is the heat-balance ratio of the air layer during the calculation step.

$$U_0 = \frac{1}{R_i + R_l + R_e} \quad (\text{E.17})$$

is the thermal transmittance of the wall.

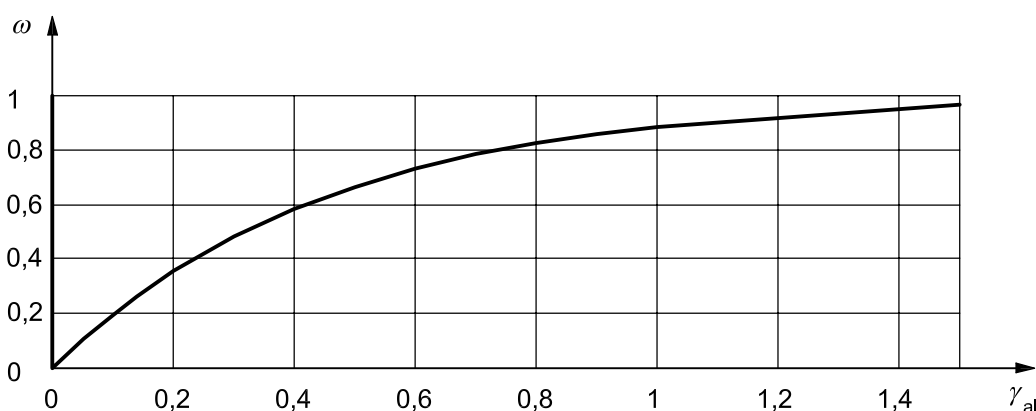

Figure E.4 — Ratio ω of the total solar radiation falling on the element when the air layer is open to the total solar radiation during the calculation step, as a function of the heat-balance ratio of the air layer, γ_{al}

b) If the air layer is covered by glazing:

$$A_{sol} = A_{sw} \alpha F_{sh} F_F g_w \left[U_0 R_e + \frac{U_0^2 R_i}{U_i U_e} \rho_a c_a \frac{q_{ve,sw}}{A} \kappa_{sw} \omega \right] \quad (\text{E.18})$$

NOTE This procedure is implicit: equations (E.15) and (E.16) should be used in an iterative process to calculate the solar heat gains, starting with $\gamma_{al} = 1$.

E.5 Ventilated envelope elements

E.5.1 Heat transfer

E.5.1.1 General

Circulating ventilation air within parts of the building envelope (wall, window, roof) decreases the overall heat losses by heat recovery, although the transmission heat loss is increased in these building envelope elements. This overall effect can be expressed through an equivalent heat exchanger between exhaust and supply air. The efficiency of this equivalent heat exchanger can be calculated with the simplified method given in E.5.1.2, which is applicable under the following conditions:

— the air flow is parallel to the envelope surface (see Figure E.5);

- the thickness of the air layer is between 15 mm and 100 mm;
- the air permeability of the remaining parts of the envelope is low, so that most (about 90 %) of the air circulating through the building passes through the ventilated envelope element;
- the ventilation system meets the requirements in Table E.2;
- air supply, if natural, is controlled through adjustable or self-controlled inlets located on the internal part of the envelope. During summer the inlets are closed.

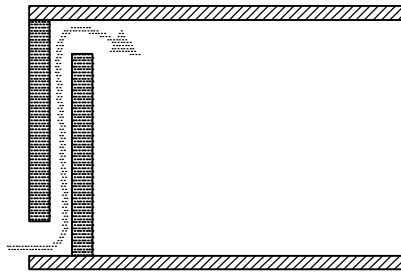

Figure E.5 — Air path in the wall

Table E.2 — Ventilation requirements for the application of the method

Shielding class	Requirement
No shielding	Mechanical exhaust and supply
Moderate	Mechanical exhaust or supply
Heavy shielding	No requirement

NOTE This method mainly applies where supply air is circulated within the building envelope elements. Exhaust air can also be used, provided that suitable provisions be made to avoid condensation.

E.5.1.2 Calculation method

The efficiency factor of the equivalent air-to-air heat exchanger is:

$$\eta_v = \frac{U_0^2}{U_i U_e} \kappa \quad (\text{E.19})$$

where

U_i and U_e are, respectively, the thermal transmittances of the internal and external parts of the envelope element containing the air space;

U_0 is the thermal transmittance of this envelope element, assuming the air space is not ventilated;

κ_{sw} is the factor defined by Equation (E.13).

This efficiency factor of the equivalent air-to-air heat exchanger is always less than 0,25.

E.5.2 Solar heat gains

E.5.2.1 General

If the supply air for ventilation is taken through envelope elements, it can be heated on the one hand by the transmission heat loss through the element (see E.5.1) and on the other hand by solar radiation absorbed either by the external opaque pane or by the internal surface of the air layer if this layer is covered by glazing.

The calculation method quantifies the positive effect during the heating season. However, the same procedure shall also be used to calculate the solar gains for the cooling (summer) mode, taking into account any extra (seasonal) solar protection and ventilation provisions, if present.

E.5.2.2 Required data

In addition to data listed in E.5.1, the following input data are necessary:

- A area of the element;
- F_F frame area fraction;
- F_{sh} shading reduction factor, calculated in accordance with 11.4.3;
- a absorption coefficient of the surface receiving the solar radiation;
- R_i internal thermal resistance of the wall, between the air layer and the internal environment;
- R_e external thermal resistance of the wall, between the air layer and the external environment;
- R_l thermal resistance of the air layer;
- $q_{ve,sw}$ air flow rate through the ventilated layer;
- h_e surface heat transfer coefficient at external surface;
- g total solar energy transmittance of the glazing covering the air layer;
- h_c convective surface heat transfer coefficient in the air layer;
- h_r radiative surface heat transfer coefficient in the air layer.

E.5.2.3 Calculation method

The efficiency of the equivalent heat exchanger is calculated in accordance with E.5.1. Solar heat gains are calculated in accordance with 11.2 using an effective collecting area.

- a) If the ventilated layer is covered by an opaque external layer:

$$A_{sol} = A \alpha F_{sh} (1 - F_F) \frac{U_0}{h_e} \left[1 + \frac{U_0}{U_i^2} \rho_a c_a \frac{q_{ve,sw}}{A} \kappa_{sw} \right] \quad (E.20)$$

- b) If the air layer is covered by glazing:

$$A_{sol} = A \alpha F_{sh} (1 - F_F) g_w \left[U_0 R_e + \frac{U_0^2 R_i}{U_i U_e} \rho_a c_a \frac{q_{ve,sw}}{A} \kappa_{sw} \right] \quad (E.21)$$

Annex F (normative)

Climate-related data

F.1 Common data

Length of time periods:

Period	Number of days	Number of hours	t Ms
January	31	744	2,678 4
February	28	672	2,419 2
March	31	744	2,678 4
April	30	720	2,592
May	31	744	2,678 4
June	30	720	2,592
Heating season	See 7.4	Days × 24	Days × 24 × 3,6 × 10 ⁻³
Cooling season	See 7.4	Days × 24	Days × 24 × 3,6 × 10 ⁻³

Period	Number of days	Number of hours	t Ms
July	31	744	2,678 4
August	31	744	2,678 4
September	30	720	2,592
October	31	744	2,678 4
November	30	720	2,592
December	31	744	2,678 4
Year	365	8 760	31,536

F.2 Climate data

F.2.1 Required data

F.2.1.1 Monthly and seasonal method

For the monthly and seasonal method the following climate data are needed:

- monthly mean external air temperature, expressed in degrees centigrade;
- monthly mean incident solar radiation for planes at relevant orientations and tilt angles, expressed in watts per kelvin.

These data shall be obtained from hourly data in accordance with the procedure given in F.2.2.

Hourly data may also be needed, e.g. to construct tables with national or regional values such as solar shading factors (see Annex G), etc.

As explained in more detail in I.5, the accumulated temperature differences (degree days) as given in ISO 15927-6^[7] are not applicable for the monthly or seasonal method. In the degree days method the heat losses by transmission and ventilation in the heating season are corrected via a reduction in the accumulated temperature difference, to correct for the fact that internal and solar gains are not taken into account; in this standard the (utilized) internal and solar gains are explicitly subtracted from the losses.

ISO 13790:2008(E)

F.2.1.2 Simple hourly method and detailed simulation methods

For the simple hourly method and detailed simulation methods, the following data are needed:

At least:

- hourly external air temperature, expressed in degrees centigrade;
- hourly incident solar radiation for planes at relevant orientations and tilt angles, expressed in watts per square metres kelvin;
- solar height and azimuth;
- day of the week.

and, if relevant:

- local or meteorological wind speed, expressed in metres per second;
- wind direction;
- albedo;
- relative humidity of external air.

These data shall also be obtained in accordance with the procedure given in F.2.2.

F.2.2 Selection of data and conversion

Hourly data for a representative year shall be selected from recent hourly weather files in accordance with the procedures described in ISO 15927-4.

These data comprise at least hourly values of:

- dry-bulb air temperature;
- direct normal solar irradiance and diffuse solar irradiance on a horizontal surface;
- relative humidity, absolute humidity, water vapour pressure or dewpoint temperature;
- wind speed at a height of 10 m above ground.

Additional data required are latitude, longitude and altitude of the station and day of the week of first day of the year (January 1st).

The calculation of the solar height and azimuth and the conversion of global solar radiation at a horizontal plane to incident radiation at vertical and tilted planes at various orientations shall be made in accordance with a recognised procedure that takes into account the breakdown into direct and diffuse radiation and all necessary goniometric conversions.

NOTE 1 For instance the Perez model in which the solar radiation is split into beam, circumsolar, homogeneously diffuse, near-horizon and ground-reflected radiation and empirical coefficients are used in the conversion for solar radiation at vertical and tilted planes. See Reference [27].

The choice of weather station may be decided nationally, depending on the purpose of the calculation.

NOTE 2 For instance a standard weather station in the case of calculations for an energy performance certificate or for checking compliance with a minimum energy performance level in the building regulations.

NOTE 3 Methods of calculation and presentation of climatic data are given in ISO 15927-1^[6].

Annex G (informative)

Simplified methods and standard input data

G.1 Scope

This annex contains simplified methods and standard input data on a number of calculation elements. In general these can be used in the absence of national values.

The order follows the order of the main part of this International Standard (transmission, ventilation, internal heat gains, solar heat gains, dynamic properties, etc.)

G.2 Simplified methods and data related to heat transfer by thermal transmission

G.2.1 Thermal bridges

In the case of old existing buildings, if no or little information is available on the thermal bridges in the construction, it might not be appropriate to use conservative default values if the purpose is to provide an (informative) energy performance certificate. Moreover, conservative default values for highly insulated buildings are not suited for poorly insulated buildings.

A simple method for this purpose may consist of default values that depend on the mean U -value of the construction and/or the age of the building.

For instance, the U -value of each opaque construction, expressed in watts per square metres per kelvin, is corrected with a surcharge that serves as a default effect of thermal bridges:

$$U_{\text{op,corr}} = U_{\text{op,mn}} + \Delta U_{\text{tb}} \quad (\text{G.1})$$

where

$U_{\text{op,mn}}$ is the mean U -value of the opaque part of the construction, excluding framed panels and ground floor, expressed in watts per square metres per kelvin;

ΔU_{tb} is the default surcharge on the U -value of opaque constructions, U_{op} , taking into account the effect of thermal bridges, expressed in watts per square metres per kelvin.

NOTE Windows and framed panels are excluded, because otherwise insulating the windows and/or panels would highly influence the default value while they normally have a relatively small effect on the thermal bridges; the ground floor is excluded because the edge effect of the ground floor is a separate issue.

Table G.1 — Example of default values for the surcharge on the U -value, to take into account the effect of thermal bridges

Mean U -value of the opaque part of the construction, excluding framed panels and ground floor ($\text{W}/\text{m}^2\text{K}$)	ΔU_{tb} ($\text{W}/\text{m}^2\text{K}$)
$U_{\text{op,mn}} \geq 0,8$	0,0
$0,4 \leq U_{\text{op,mn}} < 0,8$	0,05
$U_{\text{op,mn}} < 0,4$	0,1

G.2.2 Nocturnal insulation

G.2.2.1 All methods

Whether the effect of nocturnal insulation may be taken into account may be decided at national level, depending on the type of building and application.

G.2.2.2 Seasonal or monthly methods

The fraction of the accumulated temperature difference of the period of the day with shutters closed, f_{shut} , is, in the absence of national values, equal to the ratio of the accumulated temperature difference ($\theta_{1,\text{set,H}} - \theta_e$) over all hours with shutters closed and the accumulated temperature difference ($\theta_{1,\text{set,H}} - \theta_e$) over all hours of the calculation step (month or season).

Because of the climate dependency, values for f_{shut} may be defined at national level, if necessary with regional differentiation.

In the absence of national values it can be assumed that a window has the shutter (if present) closed from sunset until 7 am on all days for which the average day temperature is less than 10 °C.

Different patterns may be chosen for weekdays and weekend days and for different building functions.

G.3 Simplified methods and data related to heat transfer by ventilation — Free cooling and night-time ventilation during cooling mode

During the cooling mode period, the daily and weekly patterns need to be specified as well as the extra volume flow rate, as extra input to the calculation method.

At national level, the use of the extra flow rate may also be described as controlled by external or internal parameters, such as the external or internal temperature.

NOTE In the case of simplified hourly or detailed simulation methods, the use of parameter values from the previous time interval, to avoid the need for iteration, can lead to serious oscillation problems if no special precautions are taken, such as the introduction of suitable relaxation factors.

Extra flow rate, $q_{\text{ve,extra}}$:

The extra airflow rate due to night-time ventilation, $q_{\text{ve,extra}}$, may be calculated either in accordance with the relevant standard as specified in Annex A, or provided at national level based on the type of buildings, building use, climate and exposition.

Time fraction, $f_{\text{ve,t,extra}}$:

Unless otherwise defined at national level, the extra airflow rate due to free cooling or night-time ventilation, $q_{\text{ve,extra}}$, is in operation from 23 pm until 7 am for all days in the cooling season. $\Rightarrow f_{\text{ve,t,extra}} = 0,33$. This may affect the length of the cooling season and may require a repeated calculation (see 7.3).

Patterns may be different for weekdays and weekend days and can depend on the use of the building.

For monthly or seasonal methods: in the case of intermittent cooling where, following 13.2.2, the effect of intermittency is taken into account by a reduction factor on the energy need for cooling, the time fraction should ignore days with reduced cooling set-point or switch-off.

Adjustment for dynamic effects and effectiveness, $c_{ve,eff,extra}$:

Unless more information is available at national level, the value for the adjustment factor is $c_{ve,eff,extra} = 1$.

G.4 Simplified methods and data related to internal heat gains — Input data for internal heat gains from persons and appliances

Hourly and weekly schedules of heat flow rate for metabolic heat from occupants and dissipated heat from appliances shall be determined on a national basis, as a function of building use, (optionally) occupancy class and purpose of the calculation.

In the absence of national values, the values in Table G.7 may be used. Clause G.8 contains detailed values for residential buildings and offices and more global values for a number of building uses.

G.5 Simplified methods and data related to solar heat gain**G.5.1 Total solar energy transmittance for glazing**

Table G.1 provides some indicative values for the total solar energy transmittance at normal incidence, g_n , assuming a clean surface and normal, untainted and non-scattering glazing.

The values shall be multiplied with the correction factor given in 11.4.2.

Table G.2 — Typical values of total solar energy transmittance at normal incidence for common types of glazing

Glazing type	g_n
Single glazing	0,85
Double glazing	0,75
Double glazing with selective low-emissivity coating	0,67
Triple glazing	0,7
Triple glazing with two selective low-emissivity coatings	0,5
Double window	0,75

G.5.2 Effect of permanent curtains

Curtains placed “permanently” (e.g. not movable) inside or outside the windows reduce the global transmission of solar radiation. Some reduction factors are given in Table G.2. These factors are multiplied by the total solar energy transmittance of the glazing to obtain the g -factor of the glazing with permanent curtain. In this context “permanently” usually means “also in operation during daytime”.

Table G.3 — Reduction factors for some types of curtain

Curtain type	Optical properties of curtain		Reduction factor with	
	absorption	transmission	curtain inside	curtain outside
White venetian blinds	0,1	0,05	0,25	0,10
		0,1	0,30	0,15
		0,3	0,45	0,35
White curtains	0,1	0,5	0,65	0,55
		0,7	0,80	0,75
		0,9	0,95	0,95
Coloured textiles	0,3	0,1	0,42	0,17
		0,3	0,57	0,37
		0,5	0,77	0,57
Aluminium-coated textiles	0,2	0,05	0,20	0,08

For the heating mode, movable curtains and movable solar protections are taken into account in the utilization factor.

G.5.3 Movable solar shading reduction factors

G.5.3.1 General

Unless otherwise specified at national level, the solar shading shall be taken as being switched on if the intensity of the solar radiation on the surface at the given hour exceeds 300 W/m^2 and switched off if the hourly value is below this value.

NOTE The time during which the solar shading is open and closed is climate dependent. National procedures may differentiate between types of solar control, such as

- no control (not relevant here; is included in g -value of window),
- manual operation,
- motorized operation,
- blind automatic control.

G.5.3.2 Monthly method

The weighted fraction of the time during which the solar shading is in use or not in use depends on the climate and on the season or month. For each climate a table can be produced with values for f_{with} for a variety of orientations and tilt angles of the window. The resulting table can contain values per month or one average value for the heating or cooling season to be used for each month. An example is given in Table G.3. The values have been derived as the sum of the hourly values of the intensity of incident solar radiation for all hours in the month with intensity higher than 300 W/m^2 , divided by the sum of the hourly values of the intensity of incident solar radiation for all hours in the months; or: $f_{\text{with}} = I_{\text{sol}, > 300 \text{ W}} / I_{\text{sol}}$, where I_{sol} is the monthly mean solar radiation intensity.

Table G.4 — Example of table for the movable shading reduction factor, f_{with}

Month	Paris (France)				Rome (Italy)				Stockholm (Sweden)			
	N	E	S	W	N	E	S	W	N	E	S	W
1	0,00	0,15	0,58	0,09	0,00	0,52	0,81	0,39	0,00	0,10	0,71	0,00
2	0,00	0,19	0,52	0,13	0,00	0,48	0,82	0,55	0,00	0,42	0,76	0,18
3	0,00	0,53	0,76	0,44	0,00	0,66	0,81	0,63	0,00	0,56	0,77	0,47
4	0,00	0,32	0,50	0,26	0,00	0,71	0,74	0,62	0,00	0,74	0,80	0,59
5	0,00	0,31	0,44	0,27	0,00	0,71	0,62	0,64	0,02	0,70	0,71	0,59
6	0,00	0,42	0,47	0,38	0,00	0,75	0,56	0,68	0,05	0,69	0,66	0,56
7	0,00	0,51	0,59	0,40	0,00	0,74	0,62	0,73	0,03	0,67	0,65	0,53
8	0,00	0,37	0,54	0,31	0,00	0,75	0,76	0,72	0,00	0,61	0,70	0,54
9	0,00	0,28	0,52	0,20	0,00	0,73	0,82	0,67	0,00	0,58	0,70	0,44
10	0,00	0,13	0,53	0,16	0,00	0,72	0,86	0,60	0,00	0,47	0,74	0,24
11	0,00	0,08	0,47	0,09	0,00	0,62	0,84	0,30	0,00	0,19	0,62	0,00
12	0,00	0,07	0,46	0,08	0,00	0,50	0,86	0,42	0,00	0,00	0,59	0,00
Annual	0,00	0,36	0,55	0,30	0,00	0,69	0,77	0,63	0,02	0,62	0,71	0,50

In the case of intermittent heating or cooling where, following 13.2.2, the effect of intermittency is taken into account by a reduction factor on the energy need for heating or cooling, the weighted fraction should be calculated assuming continuous heating or cooling, thus disregarding days with reduced heating or cooling set-point or switch-off.

For the heating mode, the gain utilization factor may have been based on calculation cases in which an extreme solar load during the heating season is already avoided, by assuming the use of an effective solar shading provision that is in operation if I_{sol} is higher than 500 W/m^2 (see [13] and [23]). Consequently, using the values of Table G.3 leads to conservative results.

G.5.4 Shading correction factors for external obstacles

G.5.4.1 Principle

The shading correction factor for external obstacles can be calculated from:

$$F_{sh} = F_{hor} F_{ov} F_{fin} \quad (\text{G.2})$$

where

F_{hor} is the partial shading correction factor for the horizon;

F_{ov} is the partial shading correction factor for overhangs;

F_{fin} is the partial shading correction factor for fins.

G.5.4.2 Shading from horizon

G.5.4.2.1 General

The effect of shading from the horizon (e.g. the ground, trees and other buildings) depends on horizon angle, latitude, orientation, local climate and heating season. Shading correction factors for typical average Northern hemisphere climates and a heating season from October to April are given in Table G.5, for three latitudes and four window orientations. Interpolation can be used for other latitudes and orientations. The horizon angle is an average over the horizon facing the façade considered.

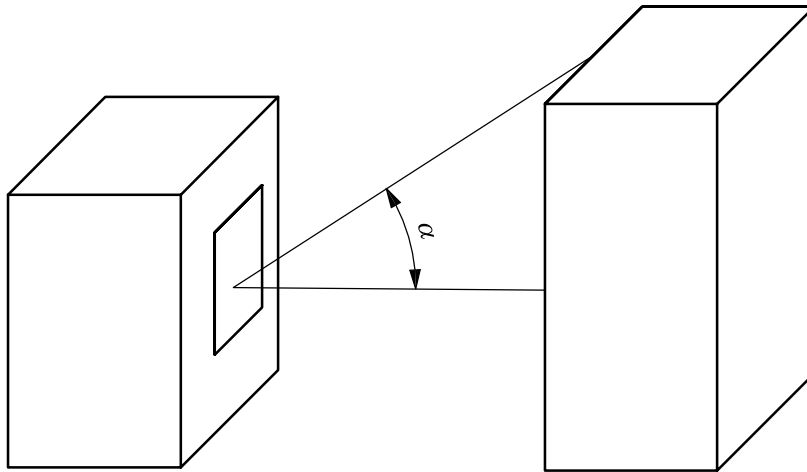

Figure G.1 — Horizon angle, α

G.5.4.2.2 Hourly calculation method

It is assumed that the horizon mask modifies only the direct solar radiation. This is consistent with the general assumption, see 11.4.4.

F_{hor} is calculated by the following:

$$\text{if } S_h < \alpha \quad F_{\text{hor}} = (1 - R_{\text{dir}}/R_{\text{tot}}) \quad (\text{G.3})$$

otherwise $F_{\text{hor}} = 1$

where

S_h is the solar height;

R_{dir} is the direct solar radiation on the façade;

R_{tot} is the total radiation on the façade.

G.5.4.2.3 Monthly or seasonal method

Table G.5 — Partial shading correction factor for horizon, F_{hor}

Horizon angle	45° N lat.			55° N lat.			65° N lat.		
	S	E/W	N	S	E/W	N	S	E/W	N
0°	1,00	1,00	1,00	1,00	1,00	1,00	1,00	1,00	1,00
10°	0,97	0,95	1,00	0,94	0,92	0,99	0,86	0,89	0,97
20°	0,85	0,82	0,98	0,68	0,75	0,95	0,58	0,68	0,93
30°	0,62	0,70	0,94	0,49	0,62	0,92	0,41	0,54	0,89
40°	0,46	0,61	0,90	0,40	0,56	0,89	0,29	0,49	0,85

The values in Table G.5 are only valid for the heating season and given location.

G.5.4.3 Shading from overhang and fins

G.5.4.3.1 General

The shading from overhangs and fins depends on overhang or fin angle, latitude, orientation and local climate. Seasonal shading correction factors for typical climates are given in Tables G.6 and G.7.

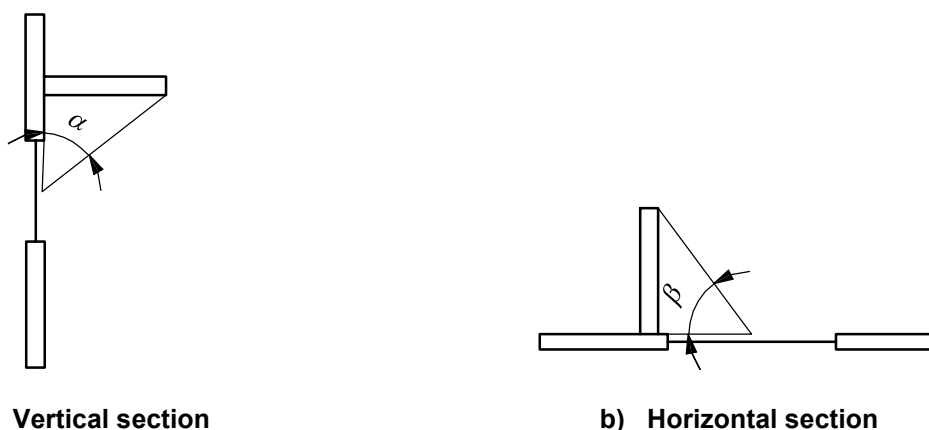

Key

α overhang angle

β fin angle

Figure G.2 — Overhang and fin

G.5.4.3.2 Hourly methods

It is assumed that the shading affects direct and diffuse radiation but not reflected radiation.

For overhangs, the partial reduction coefficients for direct radiation, $F_{ov,dir}$, and for diffuse radiation, $F_{ov,dif}$, are calculated by:

$$F_{ov,dir} = \max\{0; 1 - [0,5 \tan(\alpha)/\tan(90 - S_h)]\} \quad (G.4)$$

$$F_{ov,dif} = 1 - (\alpha/90) \quad (G.5)$$

ISO 13790:2008(E)

The coefficient F_{ov} is calculated by:

$$F_{ov} = (F_{ov,dir} R_{dir} + F_{ov,dif} R_{dif} + 1 - R_{tot})/R_{tot} \quad (G.6)$$

where R_{dif} is the ratio of the diffuse radiation for the given orientation.

G.5.4.3.3 Monthly and seasonal methods

Table G.6 — Partial shading correction factor for overhang, F_{ov}

Overhang angle	45° N lat.			55° N lat.			65° N lat.		
	S	E/W	N	S	E/W	N	S	E/W	N
0°	1,00	1,00	1,00	1,00	1,00	1,00	1,00	1,00	1,00
30°	0,90	0,89	0,91	0,93	0,91	0,91	0,95	0,92	0,90
45°	0,74	0,76	0,80	0,80	0,79	0,80	0,85	0,81	0,80
60°	0,50	0,58	0,66	0,60	0,61	0,65	0,66	0,65	0,66

Table G.7 — Partial shading correction factor for fins, F_{fin}

Fin angle	45° N lat.			55° N lat.			65° N lat.		
	S	E/W	N	S	E/W	N	S	E/W	N
0°	1,00	1,00	1,00	1,00	1,00	1,00	1,00	1,00	1,00
30°	0,94	0,92	1,00	0,94	0,91	0,99	0,94	0,90	0,98
45°	0,84	0,84	1,00	0,86	0,83	0,99	0,85	0,82	0,98
60°	0,72	0,75	1,00	0,74	0,75	0,99	0,73	0,73	0,98

The values of Table G.6 are valid for fins on one side.

For south-facing windows, for the given latitudes, with fins on both sides, the two shading correction factors shall be multiplied.

For east- and west-facing windows the shading correction factor is valid for fins at the south end of the window. Fins at the north end of the window, for the given latitudes, do not lead to a shading correction factor.

The values in Tables G.6 and G.7 are only valid for the heating season and given location.

G.6 Simplified methods and data related to indoor conditions (internal temperature set-points)

G.6.1 Explanation of intermittency correction for seasonal and monthly methods

G.6.1.1 General

The correction for intermittency for the monthly method for heating and cooling as given in 13.2.2 is based on the following.

G.6.1.1.1 Heating mode

In a simple but robust way, the correction factor takes into account that the impact of the intermittency on the energy need for heating is a function of the length of the intermittency period (hours per week), the amount of heat gains compared to the amount of heat transfer (heat-balance ratio) and the building inertia. See Figure 8.

G.6.1.1.2 Cooling mode

Due to the diurnal pattern of the weather, and the effect of the building thermal inertia, an evening/night thermostat set-back or switch-off has, in general, a much smaller effect on the energy need for cooling than a thermostat set-back or switch-off has on the heating energy need. This implies that a thermostat set-back or switch-off during evening/night will result in only a small or no decrease in energy need for cooling, except during very warm months or in the case of high internal heat gains, in combination with small heat losses. Therefore, the time fraction for intermittency in the cooling mode is based on the number of days per week with cooling instead of number of hours per week as for the heating mode. See Figure 9.

G.6.1.1.3 Operation schedules

Because in this procedure the effect of intermittency is taken into account by a reduction factor on the energy need for cooling, the time fraction of hours of operation of, for example, solar shading and free cooling or night-time ventilation shall be calculated assuming continuous heating and cooling, thus disregarding days with reduced heating or cooling set-point or switch-off.

G.6.2 Typical values and patterns for internal temperature set-points

Examples of set-point temperatures and intermittency patterns for different building types, to be used in the absence of national values are given in Table G.11 (see Clause G.8).

Measured values shall be used with care, because the measured internal temperature is not the same as set-point due to effects such as overheating, intermittency, inertia, imperfect control. These effects should not be implicitly taken into account in the set-point, because they are explicitly taken into account in the calculation method (e.g. monthly or seasonal method: overheating in utilization factor; intermittency: in set-point adjustment and/or correction factor; simple hourly and detailed simulation methods: in the set-point schedule).

G.7 Internal heat capacity

For the monthly and seasonal method, one could argue that the internal heat capacity should include the effect of the surface resistance. Such a correction, based on ISO 13786:2007, Clause A.3, would apply to each value of κ_j , resulting in a κ'_j value and hence in an overall C'_m value that is significantly lower than C_m .

By rough approximation, the correction for the surface resistance is $C'_m = 0,75 C_m$, which is based on calculations showing that the corrected heat capacity can be as low as 50 % of the uncorrected value.

However, the operative internal temperature is, by approximation, equal to the arithmetic mean of air and surface temperature. Therefore only half of the correction is needed.

In addition to this, a large portion of the solar radiation entering the building zone will impinge on the internal surface of floor and walls directly, as does part of the internal heat gains.

Moreover, the parameters of the gain utilization curves have been determined on the basis of a definition of the internal heat capacity that is close to the definition given in ISO 13786 without surface resistance.

NOTE A rough approximation of the internal heat capacity is sufficient for the purposes of this International Standard.

Consequently, the procedures ignore a correction for the surface resistance. The values may also be determined at national level.

G.8 Occupancy data

Typical occupancy-related data for residential buildings are given in Table G.8. Typical occupancy-related data for offices are given in Table G.9.

Typical internal heat flow rates as a function of occupancy and building type are given in Tables G.10 and G.11.

Table G.12 gives various types of conventional input data related to occupancy for different types of building use.

NOTE The presence of occupants, both for standard occupancy and for actual occupancy conditions, can be shorter than the hours of operation of the technical building systems.

Table G.8 — Heat flow rate from occupants and appliances; default values in the absence of national values; detailed values for residential buildings

Days	Hours	Residential buildings	
		Living room plus kitchen $(\phi_{\text{int,Oc}} + \phi_{\text{int,A}})/A_f$ W/m ²	Other conditioned areas (e.g. bedrooms) $(\phi_{\text{int,Oc}} + \phi_{\text{int,A}})/A_f$ W/m ²
Monday to Friday	07.00 to 17.00	8,0	1,0
	17.00 to 23.00	20,0	1,0
	23.00 to 07.00	2,0	6,0
	Average	9,0	2,67
Saturday and Sunday	07.00 to 17.00	8,0	2,0
	17.00 to 23.00	20,0	4,0
	23.00 to 07.00	2,0	6,0
	Average	9,0	3,83
Average		9,0	3,0

Table G.9 — Heat flow rate from occupants and appliances; default values in the absence of national values; detailed values for offices

Days	Hours	Offices	
		Office spaces (60 % of conditioned floor area) $(\Phi_{\text{int,Oc}} + \Phi_{\text{int,A}})/A_f$ W/m ²	Other rooms, lobbies, corridors (40 % of conditioned floor area) $(\Phi_{\text{int,Oc}} + \Phi_{\text{int,A}})/A_f$ W/m ²
Monday to Friday	07.00 to 17.00	20,0	8,0
	17.00 to 23.00	2,0	1,0
	23.00 to 07.00	2,0	1,0
	Average	9,50	3,92
Saturday and Sunday	07.00 to 17.00	2,0	1,0
	17.00 to 23.00	2,0	1,0
	23.00 to 07.00	2,0	1,0
	Average	2,0	1,0
Average		7,4	3,1

$(\Phi_{\text{int,Oc}} + \Phi_{\text{int,A}})$ is the heat flow rate from persons and appliances, expressed in watts.
 A_f is the conditioned floor area, defined in 6.4, expressed in square metres.

Table G.10 — Heat flow rate from occupants; default values in the absence of national values; global values as a function of occupation density, non-residential

Class of occupation density	Conditioned floor area per person m ²	Simultaneity	$\Phi_{\text{int,Oc}}/A_f$ W/m ²
I	1,0	0,15	15
II	2,5	0,25	10
III	5,5	0,27	5
IV	14	0,42	3
V	20	0,40	2

$\Phi_{\text{int,Oc}}$ is the heat flow rate from persons, expressed in watts.
 A_f is the conditioned floor area, defined in 6.4, expressed in square metres.

Table G.11 — Heat flow rate from appliances; default values in the absence of national values; global values as a function of building use, non-residential

Building use	Heat production appliances during operation time	Fraction of time present	Average heat flow rate from appliances
	$\Phi_{\text{int,A}}/A_f$ W/m ²	f_{app}	$\Phi_{\text{int,A}}/A_f$ W/m ²
Office	15	0,20	3
Education	5	0,15	1
Health care, clinical	8	0,50	4
Health care, not clinical	15	0,20	3
Catering	10	0,25	3
Shop	10	0,25	3
Assembly	5	0,20	1
Accommodation	4	0,50	2
Cell and penitentiary	4	0,50	2
Sports	4	0,25	1

$\Phi_{\text{int,A}}$ is the heat flow rate from appliances, expressed in watts.
 A_f is the conditioned floor area, defined in 6.4, expressed in square metres.

For detailed simulation methods the thermal radiative and convective portions are each 50 %, unless otherwise stated.

Table G.12 — Example of conventional input data related to occupancy

Building type Building category Input data	a	b	c	d	e	f	g	h	i) Other types				Unit
	Single-family houses	Apartment blocks	Offices	Education buildings	Hospitals	Restaurants	Trade services	Sports facilities	Meeting halls	Industrial buildings	Warehouses	Indoor swimming pools	
Internal set-point temperature in winter	20	20	20	20	22	20	20	18	20	18	18	28	°C
Internal set-point temperature in summer	26	26	26	26	26	26	26	26	26	26	26	28	°C
Area per person (occupancy)	60	40	20	10	30	5	10	20	5	20	100	20	m ² /person
Average heat flow per person	70	70	80	70	80	100	90	100	80	100	100	60	W/person
Metabolic gain per conditioned floor area	1,2	1,8	4,0	7,0	2,7	20,0	9,0	5,0	16,0	5,0	1,0	3,0	W/m ²
Presence time per day (monthly average)	12	12	6	4	16	3	4	6	3	6	6	4	h
Annual electricity use per conditioned floor area ^a	20	30	20	10	30	30	30	10	20	20	6	60	kWh/m ²
Part of electricity use within conditioned part of building	0,7	0,7	0,9	0,9	0,7	0,7	0,8	0,9	0,8	0,9	0,9	0,7	—
Airflow rate with external air per conditioned floor area ^a	0,7	0,7	0,7	0,7	1,0	1,2	0,7	0,7	1,0	0,7	0,3	0,7	m ³ /(h·m ²)
Airflow rate with external air per person	42	28	14	7	30	6	7	14	5	14	30	14	m ³ /(h·person)
Heating need for hot water per conditioned floor area ^a	10	20	10	10	30	60	10	80	10	10	1,4	80	kWh/m ²

^a These figures refer to the gross conditioned area, calculated with external building dimensions. This area includes all conditioned space contained within the thermal insulation layer. For example, an internal unheated (but indirectly heated) staircase is included, but a cellar is not.

EN 15316-3-1:2007, Annex A, provides information on the used volume of hot water in various types of building.

The average internal heat gains, Q_{int} , can be normalized to conditioned floor area. It can be calculated from:

$$Q_{int} = A_f \left(\frac{Q_P}{A_P} + f_E q_E \right) \quad (G.7)$$

where

A_f is the conditioned floor area used for the calculations;

A_P is the conditioned floor area per person (occupancy);

Q_P is the average heat gain per person;

q_E is the electricity use per reference floor area;

ISO 13790:2008(E)

NOTE This quantity q_E serves to compute internal heat gains. It is the electricity not already taken into account for heating, cooling or hot water.

f_E is the fraction of the total electricity used within the building, i.e. the part of the electricity used that is transformed into heat within the conditioned space. This factor equals 1 if there are no electrical appliances outside the conditioned space.

Annex H (informative)

Accuracy of the method

H.1 Scope

This annex provides details related to the accuracy of the method. This includes an introduction on the need for a balance between the accuracy of the method, the quality of the input data and the reproducibility of the results. It also includes a discussion on validation of the calculation methods.

This is important information for making the choice, at national or individual level, between the different methods and options offered in this International Standard. Normally, such a choice will strongly depend on the type of application.

H.2 Balanced accuracy

H.2.1 Introduction

There are a number of quality aspects associated with calculation methodologies which are used in the context of building regulations. In particular, when the calculation procedures are used to judge compliance with minimum energy performance requirements, or to assess the energy performance rating and classification on an official energy performance certificate, it is important to find the right balance between the accuracy of the method, the quality of the input data and the reproducibility of the results. An extensive discussion on the pros and cons of different types of methods is given in Reference [24]).

Figure H.1 shows a brief overview of the most relevant quality aspects. Depending on the application, each aspect is less or more important. A brief explanation on each quality aspect is given below, after a brief discussion of the main aspects.

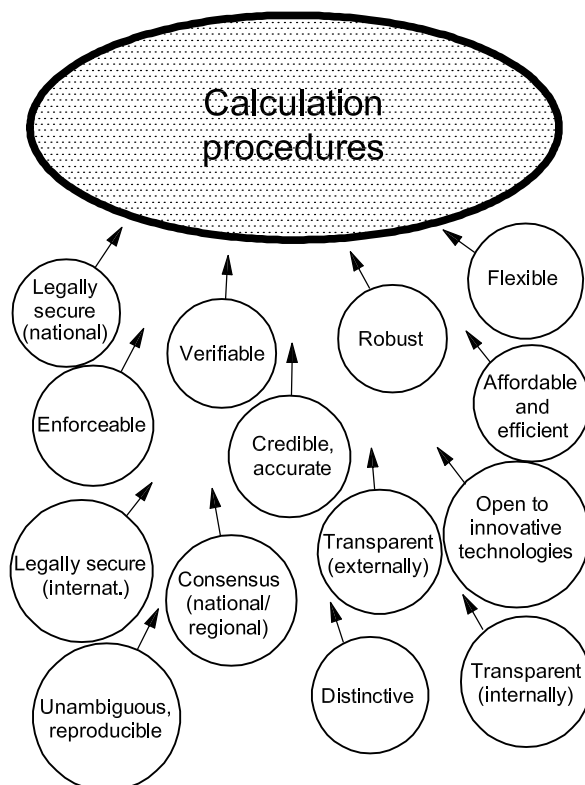

Figure H.1 — Illustration of various quality aspects for calculation procedures used in the context of building regulations

H.2.2 Discussion

Some of the quality aspects go hand in hand, e.g. “unambiguous”, “transparent” and “robust”. Other quality aspects may be more or less contradictory, e.g. “unambiguous” versus “flexible”, “accurate” and “distinctive” versus “affordable”. For those aspects, a balance needs to be found, depending on the application.

Transparency, robustness and reproducibility are very important qualities when calculating the energy performance in the context of building regulations, in particular when judging compliance with the minimum energy performance requirements for new buildings and major renovations.

The transparency, robustness and reproducibility are of interest from different perspectives:

- for persons applying the method, because it enables them to understand the method (fast learning curve), protects them against wrong use and provides the insurance that the calculation result will be accepted without discussion;
- for persons judging calculation results for legal issues, e.g. civil servants judging building permit requests, for whom avoiding ambiguities and disputes is also a major concern;
- for persons involved in further development and/or evaluation of the method and providers of the input data, for whom keeping track of the procedures is essential.

Reproducibility may be most important for energy performance requirements (new buildings and major renovations), because, in the case of strict requirements economic, pressure is high on those who are to find and apply the method that gives the best energy performance value for the lowest investment in energy technologies. This can lead to comparisons between different alternative calculation methods in order to find the best energy performance value (“shopping behaviour”), instead of comparing alternative energy-efficient technologies.

As long as the most accurate calculation gives the best value and the less detailed ones give slightly worse values the problem is less acute, but still not efficient: the better value is only better on paper and does not lead to energy saving.

H.2.3 Simplicity: simple method or just simple input?

In the discussion on the quality aspects, there is a tendency to focus on simple input rather than simple methods. These two issues should, however, be clearly distinguished:

- simplified input should be unambiguous (when selecting and when judging), distinctive (in energy performance), measurable, verifiable and maintainable (to guarantee performance over many years);
- simplified methods should combine transparency, reproducibility and robustness with adequate (balanced) accuracy.

For tailored advice, a more detailed method may provide higher flexibility and perhaps a more direct link with building simulation tools used for design purposes. In practice, these tools function as a “black box”: even for experienced users it is very difficult or even impossible to follow what happens inside the calculation core. Their application range may be larger, as well as their accuracy, although, concerning the accuracy, the limitation usually comes from the input data. A user-friendly interface can help to simplify the input, but a number of the important quality aspects for applications with legal implications are still difficult to satisfy. An extensive discussion on these topics can be found in the ENPER B6 report [24].

H.2.4 Overview of most relevant quality aspects

Legally secure: the method shall be in accordance with (inter-)national/regional regulations (e.g. respect legal principles on rights and duties with respect to adjacent buildings); the method provides a level playing field for different solutions.

Unambiguous, reproducible: for a specific case the method leads to the same result, independent of subjective or arbitrary choices. The method is independent of the user. All interested parties agree on the input, applied method and results. This requires that all options be specified in a concrete and unambiguous way, with no open ends.

Enforceable: the features (input) that have led to the calculated energy performance should not deteriorate easily or quickly, e.g. by short lifetime (bad quality) or by user interventions (bad maintenance or replaced by worse-performing provision or by control adjustments due to comfort complaints).

Verifiable: all interested parties can check the input and applied method. All input data should be available for verification at appropriate time.

Consensus (national/regional): The method (including any default values on input variables) is accepted by (or enforced upon) all involved parties.

Credible and accurate: The method should have sufficient accuracy, in order to produce results that are fair and objective for different solutions and close to the reality (if applicable: for standardized use).

Distinctive: A relevant improvement in design or technical provision should have a visible effect on the calculated EP.

Transparent (internal): The persons responsible for the methodology should be able to keep track of each step in the calculation procedure. This is achieved if the method is clearly described as a set of equations and parameters, limited in size and complexity, with clear rules on when and how these are to be applied. The term transparency can be interpreted as “containing no parameter values with unknown background”. Internal transparency is linked to the quality aspect “robust”.

ISO 13790:2008(E)

Transparent (external): the market parties, the users and the authorities should be able to understand the overall result and the results at component level, to understand and accept the effect of choices (input) on the calculation result.

Robust: robustness means that the method can handle a wide variety of situations, with limited loss of accuracy. This is achieved by the transparency in combination with ensuring that the set of equations have a physical basis, are basically non-dimensional (thus valid from small home to large building), with parameters that are “intrinsically safe” (e.g. a non-dimensional reduction factor with value between 0 and 1).

NOTE Robustness is a term that also applies to the energy-saving provisions: the performance of a more robust provision is less dependent on user and/or control aspects for example.

Affordable and efficient: the method should be affordable for the user: the costs (easy to acquire and learn, easy on the input) should be in balance with the benefits.

Innovative, open to future developments: the method should not hinder the implementation of (proven) innovative design and technologies.

Flexible: the method should be able to cope with non-standard input data.

H.3 Error analysis

H.3.1 Propagation of errors

The accuracy of the method, that is the extent to which the results of the calculation correspond with the actual energy use of the building, depends mainly on the quality of the input data, and some of these data (e.g. the air change rate) are often not known precisely.

The uncertainty of input data propagates through the formulae and equations, resulting in a generally larger relative error in the results. In particular, when the heat gains are high, the small energy need for heating results from the subtraction of two large numbers, and the factor multiplying the uncertainty on heat transfer and heat gains becomes large. Error analysis has shown that when the heat-balance ratio is 0,75, this factor is between 4 and 7, depending on the time constant of the building. In this case, an uncertainty of 5 % on heat transfer by transmission and ventilation will result in an uncertainty of 20 % to 35 % on the energy need for heating.

Therefore, it is advisable, when the annual need for heating is less than one third of the heat transfer, to take great care with input data, and to perform an error analysis taking account of the uncertainties of the input data.

When this International Standard is used to judge compliance with regulations expressed in terms of energy targets, the calculation is based on conventionally well-defined (standard) input data. In this case, the error analysis is not necessary.

In the case of calculation of the energy performance of old existing buildings, if gathering the full required input would be too labour-intensive for the purpose, relative to the cost-effectiveness of gathering the input, it may be decided at national level to restrict the possible choices of input data in order to reduce the risk of errors in the input.

H.3.2 Comparison with actual buildings

In particular, if the calculations are made using standard values for the behaviour of the occupants and airflow rates, significant differences can occur with the energy used that is actually measured. In practice, these factors may change the energy use from 50 % to 150 % of the calculated average value, and even more in terraced houses and blocks of flats, where moderate temperature differences between adjacent zones often result in noticeable heat transfer between them.

H.3.3 Comparison between building designs

The method described in this International Standard is particularly appropriate for comparison between building designs in order to determine the influence of various options on the energy use. Insofar as these options are taken into account in the calculation, their relative influence is well predicted.

H.3.4 Comparison with detailed simulation methods

For detailed dynamic simulation methods, the input data are sometimes more detailed than for the seasonal, monthly or simple hourly methods. However, if the basic physical data and the assumptions (on relevant environment conditions, user behaviour and controls) are in accordance with the specifications in this International Standard (“level playing field”), then the annual energy use calculated by the simple hourly method and the monthly and seasonal methods described in this International Standard are, on average, in very good agreement with the results from a detailed simulation tool.

However, this is only true if the algorithms in the detailed simulation tool are based on the same or similar assumptions as used for the methods described in this International Standard. See also 7.2.3 on validation of detailed simulation methods. Consequently, the range of results is much larger if it includes the uncertainty due to influencing factors (like interaction between zones, air infiltration, dynamic heat transfer to ground floor, thermal bridges, solar shading by external obstacles, etc.) for which the choice of an accurate and practical method, also for a detailed simulation tool, is to some extent arbitrary.

H.3.5 Simple hourly versus monthly method

The main advantage of the simple hourly method over the monthly method is that the hourly time intervals enable direct input of hourly patterns.

On the other hand, the main disadvantage of the simple hourly method compared to the monthly method is that the output from the simple hourly method is obtained from direct calculation using a simplified model, while in the monthly method the correlation coefficients are based on the results of series of detailed simulation tools, where more complex dynamic effects can be taken into account, which are consequently implicitly reflected in the correlation coefficients.

A more detailed discussion can be found in Reference [24].

H.3.6 Comparison between users of the standard

It has been shown, by round robin tests, that different users may obtain results differing by as much as 20 % for the same building in the same climate, for the following reasons:

- the standard allows for input data defined on a national basis, which may differ between users;
- the standard allows different calculation methods (e.g. single- or multi-zone);
- the user may provide different input data from the same source (e.g. by taking dimensions from a drawing).

This International Standard provides the means of reaching a highly reproducible result, by allowing that at several levels it may be decided, e.g. on a national basis, depending on the purpose of the calculation, to prescribe specific options, boundary conditions and/or input data.

H.4 Validation

H.4.1 General

Evidently, calculation procedures should have been thoroughly validated before adopting them in an International Standard. However, the number of internationally available test cases and corresponding validation criteria that can be used to guarantee only small differences in results are small in number and scope. For instance, the IEA BESTEST cases allow, depending on the case, a bandwidth between 50 % and 150 % deviation from the reference result. These cases are good enough to filter out the obviously wrong methods, but not good enough to ensure as high a reproducibility as may be required in the context of building regulations. One of the main reasons for the wide bandwidth is that each method is allowed to use its own algorithms, sometimes simplified, sometimes more detailed.

This is due to two reasons:

- the level of detail required differs, depending on the focus of the calculation; it would be inappropriate to specify this level in a universal way;
- there is no international agreement yet on the minimum requirements for the calculations, when it comes to specific details of the calculation (e.g. angular effect of solar transmittance of glazing and solar shading provisions) and when it comes to technical building systems for heating, cooling and ventilation.

The bandwidth can be significantly reduced if the assumptions, boundary conditions and calculation algorithms (or at least the simplifying assumptions) are specified in more detail.

EN 15265 provides test cases with a small bandwidth. However, the scope of that standard is limited to validating the monthly energy needs for heating and cooling of a single room. The test cases are typical cases, with, in total, 12 variations: continuous and intermittent heating/cooling, heavy and lightweight construction, high and low internal gains, with and without roof. The cases do not comprise ground-floor heat transfer or heat transfer to adjacent enclosed spaces. The input data for thermal and solar transmittance of the glazing and for ventilation are simplified, fully prescribed data.

Some results obtained with this standard are presented in Clause H.5.

H.4.2 Validation of detailed simulation methods

Concerning validation of detailed simulation methods, see H.4.1 and 7.2.3.

H.4.3 Validation simple hourly calculation method

An introduction on the simple hourly method is given in 7.2.2.

The simple hourly method has been subjected to the test cases of EN 15265. The results passed the criteria given in that document.

Note that the validation concerns only limited test cases (only climate in Paris and only limited scope of test cases, as explained above).

Note also that the validation criteria in EN 15265 cover only monthly results. Consequently, the hourly results produced by the simple hourly method shall only be regarded as illustrative.

H.4.4 Validation monthly calculation method

An introduction on the monthly calculation method is given in 7.2.1. H.3.5 describes the main difference compared to the simple hourly method.

The monthly method has also been subjected to the test cases of EN 15265^[11] (see Reference [25]).

Preliminary reference calculation results were available from detailed simulation methods and the simple hourly method. Results from the monthly method were compared with data from these reference calculations.

The set of test cases in EN 15265 comprises only results for one climate (Paris, France). Two more extreme European climates were added: Stockholm (Sweden) and Rome (Italy). The hourly data for these climates were generated within the projects IEA SHC Task 27 (solar façade components) and EU Swift.

The following graphs show a summary of the results, organized per climate.

The differences are given as the difference in calculated monthly energy needs for respectively heating and cooling, expressed as a percentage of the annual energy needs for heating *plus* cooling.

It is clear that this may give too optimistic a view in some cases, but otherwise we would need to show all the detailed results in its detailed context. For instance: a relative difference of, say, 30 % in energy need for cooling has no real meaning if the absolute level of cooling is negligible compared to the energy need for heating.

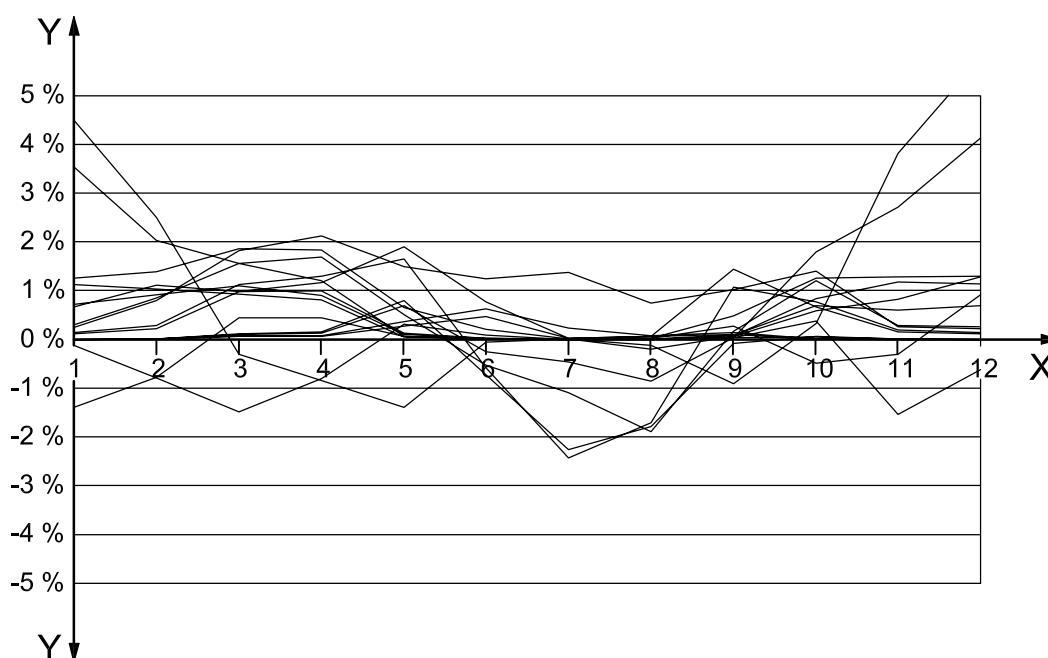

Key

- X month
- Y relative difference in percent of annual heating plus cooling

Figure H.2 — Summary of results for Paris

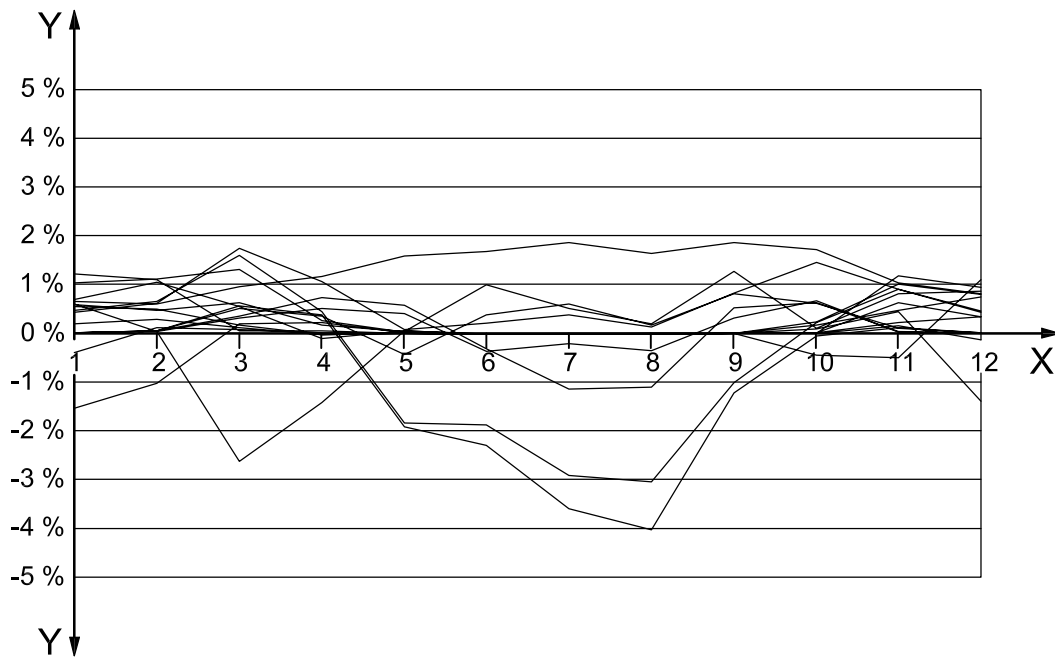
**Key**

X month

Y relative difference in percent of annual heating plus cooling

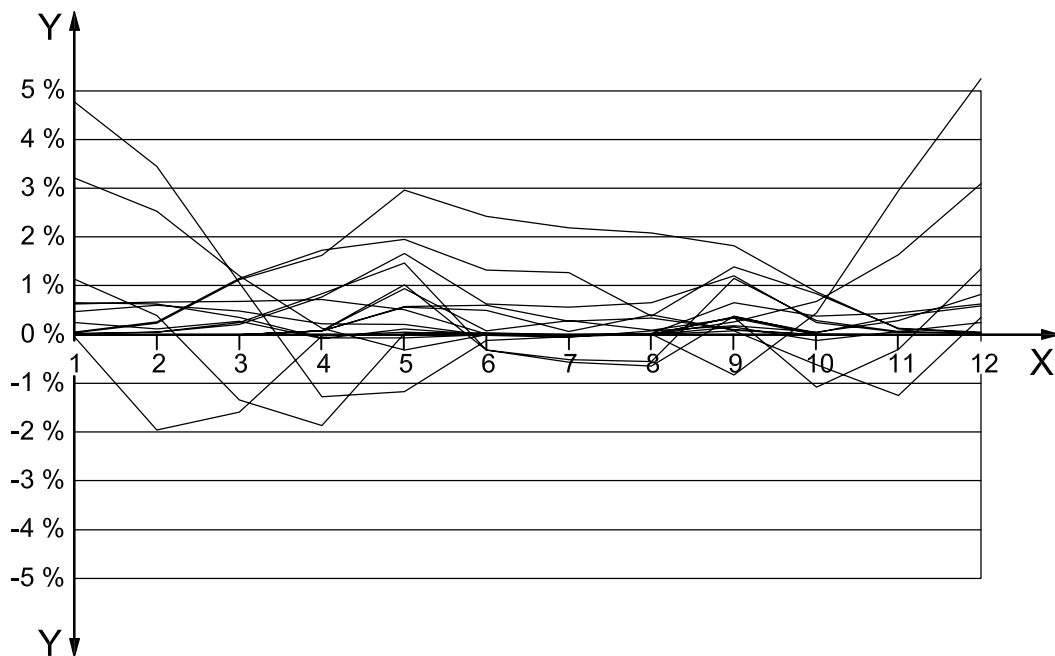
Figure H.3 — Summary of results for Rome**Key**

X month

Y relative difference in percent of annual heating plus cooling

Figure H.4 — Summary of results for Stockholm

Table H.1 shows a summary of the agreement on an annual basis.

Table H.1 — Summary of results on annual basis

Deviation (root mean square for 8 cases)	Paris	Rome	Stockholm
Heating	10 %	3 %	8 %
Cooling	6 %	8 %	7 %

The following remarks can be made regarding the results for Paris, Rome and Stockholm.

- Some deviations occur, as expected, in particular near the edges of the heating and cooling seasons.
- Results for cooling (see summer months) are not worse than for heating (see winter months).
- There is no systematic influence of climate.
- Fine-tuning of the method(s), in particular for intermittent heating and cooling, is possible, e.g. at first instance at national level, which will further decrease the discrepancies. In fact, the presented results were obtained with a draft version of the monthly method. Some fine-tuning already took place with respect to the calculation of the time constant of the building, which is not yet reflected in the results presented in this clause.

Finally, a more fundamental consideration: all discrepancies should be regarded from the perspective of the need to find the right balance between accuracy, quality of input data and reproducibility, as discussed in H.2. Deviations due to simplifications shall be considered in the context of overall uncertainties and weighted against the introduction of other uncertainties in the case of detailed methods.

Validation exercises have shown that the uncertainties that are introduced are within an acceptable bandwidth, compared to the other uncertainties, in particular when taking into account the need for these simplified methods in terms of transparency, robustness and reproducibility for use in the context of building regulations.

Annex I (informative)

Explanation and derivation of monthly or seasonal utilization factors

I.1 Scope

This annex provides an explanation of the monthly and seasonal gain and loss utilization factors. A correct understanding is important to avoid erroneous use of these concepts. It also lays the ground for the procedures to derive the utilization factors, given in I.3.

I.2 Explanation

I.2.1 Introduction

I.2.1.1 General

In the quasi-steady-state (monthly or seasonal) methods, the dynamic effects are taken into account by introducing correlation factors: the gain and/or loss utilization factors, with correction factors for intermittent heating and cooling.

I.2.1.2 Heating mode

For heating, a utilization factor for the internal and solar heat gains takes account of the fact that only part of the internal and solar heat gains is utilized to decrease the energy need for heating, the rest leading to an undesired increase of the internal temperature above the set-point.

In this approach, the non-utilized heat gains are omitted from the heat balance equation. This is counterbalanced by the fact that the extra transmission and ventilation heat transfer resulting from the non-utilized heat gains are also omitted from the heat balance equation: the transmission and ventilation heat transfer is calculated on the basis of the internal set-point temperature for heating, thus ignoring overheating (if any). Non-utilized heat gains lead to increased internal temperature above the set-point and consequently to the extra transmission and ventilation heat transfer. In other words: the gain utilization factor is a measure of the amount of overheating.

The detour (heat transfer based on set-point temperature → gain utilization factor → energy need for heating and mean internal temperature) is needed, because the utilization factor (and/or mean internal temperature) is a function of, among others, the ratio between the heat transfer based on set-point temperature and the heat gains.

The corresponding reduced and full equations are presented in I.2.2.

The effect of thermal inertia in the case of intermittent heating or switch-off can be taken into account by introducing an equivalent internal temperature which deviates from the set-point, or by a correction on the calculated heat need.

I.2.1.3 Cooling mode

For cooling there are two different ways to represent the same method.

a) Utilization factor for losses

A utilization factor for the transmission and ventilation heat transfer takes account of the fact that only part of the transmission and ventilation heat transfer is utilized to decrease the cooling needs; the “non-utilized” transmission and ventilation heat transfer occurs during periods or intervals (e.g. nights) when they have no effect on the cooling needs occurring during other periods or moments (e.g. days).

In this approach, the transmission and ventilation heat transfer in the heat balance equation are calculated on the basis of the internal set-point temperature for cooling, thus ignoring the fact that this set-point is not always reached. The loss utilization factor provides the necessary correction. With this formulation it is explicitly shown how the heat transfer contributes to the reduction of the building energy needs for cooling.

The corresponding reduced and full equations are presented in I.2.2.

b) Utilization factor for gains (similar as for heating)

A utilization factor for the internal and solar heat gains takes account of the fact that only part of the internal and solar heat gains is compensated by thermal heat transfer by transmission and ventilation, assuming a certain maximum internal temperature. The other (“non-utilized”) part leads to cooling needs to avoid an undesired increase of the internal temperature above the set-point.

In this approach, the utilized heat gains are omitted from the heat balance equation. This is counterbalanced by the fact that all transmission and ventilation heat transfer are omitted from the equation as well. These two omitted terms are equal.

The effect of thermal inertia in the case of intermittent cooling or switch-off is taken into account separately (depending on the conditions, by introducing an adjusted set-point or by an adjustment on the calculated cooling needs). See Clause 13.

This International Standard specifies in the category of quasi-steady-state methods a monthly and seasonal method for heating and cooling (presentation type a). The alternative formulation for the monthly cooling method (presentation type b) is presented in Annex D.

I.2.2 Energy balance equations

As explained above, the monthly (or seasonal) method uses, for the heating mode, a reduced heat balance equation, leaving out two equal terms: non-utilized heat gains and extra heat transfer by transmission and ventilation due to overheating.

The monthly (or seasonal) energy need for space heating is calculated according to:

$$Q_{H,nd} = Q_{H,ht} - \eta_{H,gn} Q_{H,gn} \quad (I.1)$$

The monthly (or seasonal) energy need for space cooling is calculated according to:

$$Q_{C,nd} = Q_{C,gn} - \eta_{C,ls} Q_{C,ht} \quad (I.2)$$

where

$Q_{H,ht}$ is the total heat transfer by transmission and ventilation of the building, expressed in megajoules, for the heating mode;

$Q_{C,ht}$ is the total heat transfer by transmission and ventilation of the building, expressed in megajoules, for the cooling mode;

ISO 13790:2008(E)

$Q_{H,gn}$ represents the total solar and internal heat gains of the building, expressed in megajoules, for the heating mode;

$Q_{C,gn}$ represents the total solar and internal heat gains of the building, expressed in megajoules, for the cooling mode;

$\eta_{H,gn}$ is the dimensionless gain utilization factor for heating;

$\eta_{C,ls}$ is the dimensionless loss utilization factor for cooling.

The index H for heating and C for cooling is omitted in the following equations.

The total monthly heat transfer of the building by transmission and ventilation, Q_{ht} , is given by:

$$Q_{ht} = Q_{tr} + Q_{ve} = (H_{tr,adj} + H_{ve,adj})(\theta_{int,set} - \theta_e)t \quad (1.3)$$

where

Q_{tr} is the total heat transfer of the building by transmission, expressed in megajoules;

Q_{ve} is the total heat transfer of the building by ventilation, expressed in megajoules;

$H_{tr,adj}$ is the heat transfer coefficient by transmission, adjusted for the indoor-outdoor temperature difference (if applicable), expressed in watts per kelvin;

$H_{ve,adj}$ is the heat transfer coefficient by ventilation, adjusted for the indoor-outdoor temperature difference (if applicable), expressed in watts per kelvin.

The adjustment for the internal/external temperature difference refers to cases where the temperature at the other side of the construction for transmission, or the supply temperature for ventilation is for one or more elements not equal to the external temperature, as explained in 8.3 and 9.3 respectively.

The total monthly heat gains, Q_{gn} , of the building by internal and solar gains are:

$$Q_{gn} = Q_{int} + Q_{sol} \quad (1.4)$$

where

Q_{int} is the sum of internal heat gains of the building, expressed in megajoules;

Q_{sol} is the sum of solar heat gains of the building, expressed in megajoules.

Full equations:

The real heat transmission is equal to:

$$Q_{H,ht,real} = (H_{tr,adj} + H_{ve,adj})(\theta_{int,mn} - \theta_e)t \quad (1.5)$$

where $\theta_{int,mn}$ is the real mean indoor temperature (in contrast to set-point), expressed in degrees centigrade.

The real heat gain is equal to $Q_{H,gn}$ (in contrast to the utilized heat gains: $\eta_{H,gn} Q_{H,gn}$).

Consequently, the full equation for the monthly energy need for space heating is (1.6):

$$Q_{H,nd} = Q_{H,ht,real} - Q_{H,gn} \quad (1.6)$$

As explained in I.2, this equation is of no practical use, because $\theta_{int,mn}$ is unknown. More information is given in I.4, in particular on the relation between the gain utilization factor and overheating ($\theta_{int,mn} - \theta_{int,set}$) and in I.5, on the difference with the degree days or degree hour method.

Similarly, the full equation for the monthly energy need for space cooling is given by Equation (I.7):

$$Q_{C,nd} = Q_{C,gn} - Q_{C,ht,real} \quad (I.7)$$

I.2.3 Heat-balance ratio: the difference between gains and heat transfer

The heat-balance ratio, γ , has been defined as the ratio between the heat gains, Q_{gn} , and the heat transfer by transmission and ventilation, Q_{ht} .

Although, in particular in the heating mode, the ratio looks as if it concerns simply the ratio between the incoming amounts of heat (internal and solar heat gains) and the heat leaving the building or building zone (transmission and ventilation), the actual difference is that the “gains” are actually all heat flows (positive or negative) that are (true or by approximation) given as constant heat flux, such as the solar and internal heat gains, that are not (or only weakly) dependent on the internal temperature. If the internal temperature rises due to overheating, this does not result in a proportional decrease of the internal and solar heat gains.

The heat transfer concerns all heat flows (positive or negative) that are true or by approximation strongly dependent on the internal temperature, such as the transmission and ventilation heat transfer. If the internal temperature rises due to overheating, the transmission and ventilation heat transfer from the considered zone to the outside will increase, proportional to the change in temperature difference between internal and external temperature. The same for incoming heat transfer (negative heat transfer, e.g. transmission from an adjacent warm zone, or ventilation with constant supply temperature that is higher than the internal temperature in the considered zone) this negative heat transfer will be decreased proportionally with the change in temperature difference. Consequently, negative heat transfer is taken into account under the heat transfer term and not under the heat gains term.

In I.3 instructions are given on how to generate the utilization factors for the monthly method.

I.3 Derivation of utilization factors from dynamic simulations

I.3.1 Introduction

The utilization factors are a function of the heat-balance ratio and the time constant of the building or building zone.

The parameter values in the utilization factors curves, a_0 and τ_0 , are empirical values and may be determined at national level, depending on the purpose of the calculation. National values shall be obtained by parameter identification or regression analysis techniques applied on results obtained from a representative variety of calculation cases using an appropriate detailed dynamic simulation method. In the absence of national values the tabulated values given in 12.2.1 may be used.

This International Standard creates an equivalence between the seasonal and monthly method, the simple hourly method and the dynamic simulation methods. Together with the instructions given in I.4 on how to derive parameter values for the utilization factor curves, this provides a basis for better international understanding. It is expected that this will lead in a few years' time to increased experience which can be used for further international harmonization.

I.3.2 General procedures

The parameter values used to determine the utilization factors curves in 12.2.1, a_0 , τ and τ_0 , are obtained by parameter identification or regression analysis techniques, comparing for a series of situations the values for the monthly energy needs for heating and cooling calculated with an appropriate detailed simulation method, with the results from the monthly method.

This requires that, for each value of the monthly energy need for heating or cooling calculated using the detailed simulation method, we know the associated input for the monthly method: monthly heat transfer by transmission and ventilation plus the monthly internal and solar heat gains.

Although this seems trivial, in practice it appears to be difficult not to introduce small errors (“noise”). Because the utilization factors are based on the small difference between two large numbers, a small error may already lead to large differences in results.

Typical errors encountered are as follows.

- If, in the detailed simulation method, the internal air temperature is used as heating set-point instead of the internal operative temperature:

the transmission heat transfer is not driven by the air temperature, but by some weighted mean of the temperature of the internal air and the internal surfaces of the building or building zone's envelope, which is lower; the building or building zone is actually colder than suggested by the air temperature set-point; consequently, if in the monthly method this air set-point temperature is used to calculate the monthly transmission heat transfer, the transmission heat transfer will be overestimated and vice versa for ventilation heat transfer.

- The monthly solar heat gain is normally calculated as the total amount entering the building zone via the building zone's envelope:

in the detailed simulation method, some (small) part of the solar radiation may leave the building zone directly via another window, and/or some part of the internal or solar heat gains may leave the building zone indirectly via absorption and subsequent transmission in the ground floor (or wall or roof); these parts of the heat gains remain undetected by the thermostat in the detailed simulation method, the actual solar heat gains are smaller than assumed, which leads to difficulties in matching the results of the monthly method and detailed simulation method, unless one is aware, of and able to quantify, this effect.

Differences due to different algorithms or assumptions with regard to details such as the conversion of global solar radiation to vertical solar radiation, the effect of solar shading by external obstacles, the effect of wind or sky radiation or temperature on surface heat transfer coefficients, the effect of thermal bridges, the angle-dependent solar properties of windows, the ground-floor heat transfer, etc., can be avoided by applying the procedures in this International Standard which are intended to create an equivalence between the monthly method and the detailed simulation method in this respect.

I.3.3 “Black box” approach

A way of obtaining the input data needed for the monthly method from the detailed simulation method, avoiding the pitfalls mentioned in I.3.2, is the following.

The procedure requires that three extra calculations be done with the detailed simulation method (see References [2] and [12] in the Bibliography):

- Case 0: normal calculation to obtain $Q_{H,nd,0}$ and $Q_{C,nd,0}$.
- Case 1: as case 0, but zero internal and solar heat gains and zero extra heat flow due to thermal radiation to the sky, to obtain $Q_{H,nd,1}$ and $Q_{C,nd,1}$.

Result, as a good approximation:

$$Q_{H,ht} = Q_{H,nd,1} \text{ and } Q_{C,ht} = Q_{C,nd,1} \quad (1.8)$$

- Case 2: as case 0, but a high set-point for heating and a low set-point for cooling, such that all heat gains are utilized in heating mode and all losses are utilized in cooling mode, to obtain $Q_{H,nd,2}$ and $Q_{C,nd,2}$.
- Case 3: as case 2, but with zero internal and solar heat gains and zero extra heat flow due to thermal radiation to the sky, to obtain $Q_{H,nd,3}$ and $Q_{C,nd,3}$.

Result, as a good approximation:

$$Q_{H,g} = (Q_{H,nd,3} - Q_{H,nd,2}) \text{ and } Q_{C,g} = (Q_{C,nd,2} - Q_{C,nd,3}) \quad (1.9)$$

I.3.4 Main equations

With the monthly energy needs for heating and cooling, $Q_{H,nd,0}$ and $Q_{C,nd,0}$, obtained from the detailed simulation method and the corresponding values for the monthly heat gains, $Q_{H,gn}$ and $Q_{C,gn}$, and the monthly heat transfer, $Q_{H,ht}$ and $Q_{C,ht}$, for instance from the “black box” approach given in I.3.3, the utilization factors can be obtained from the following equations:

$$\eta_{H,gn} = (Q_{H,ht} - Q_{H,nd,0})/Q_{H,gn} \quad (I.10)$$

$$\eta_{C,ls} = (Q_{C,gn} - Q_{C,nd,0})/Q_{C,ht} \quad (I.11)$$

with corresponding values for the heat-balance ratios:

$$\gamma_H = \frac{Q_{H,gn}}{Q_{H,ls}} \quad \text{and} \quad \gamma_C = \frac{Q_{C,gn}}{Q_{C,ls}} \quad (I.12)$$

The utilization factors are a function of the heat-balance ratio and the time constant of the building or building zone. The parameter values for the utilization factors curves, a_0 , and τ_0 (see 12.2.1) are obtained by parameter identification or regression analysis techniques applied on results obtained from a representative variety of calculation cases. Also, the best way to approximate the value for the time constant, τ , can be taken into consideration.

Concerning Equation (I.10).

- If the energy need for heating is zero, the utilization factor equals the reciprocal number of the heat-balance ratio, γ_H .
- In the case of low values for the heat-balance ratio, γ_H , thus with small heat gains, $Q_{H,gn}$, compared to the heat transfer, $Q_{H,ht}$, the value for the utilization factor becomes almost undeterminable: the two terms in the numerator are almost equal, while the denominator is small. Insignificant differences (“noise”) lead to large variations in the obtained utilization factor. In reality the utilization factor simply has the value $\eta_{H,gn} = 1$ for low γ_H . One way to avoid this mathematical problem is to perform the parameter identification or regression analysis, not on $\eta_{H,gn}$, but on the so-called relative overheating, $dT_{R,H}$, as introduced in Clause I.4:

$$dT_{R,H} = (Q_{H,nd,0} + Q_{H,gn})/Q_{H,ht}$$

This quantity is much more mathematically robust, also for low values of the gains.

- If the calculation cases also comprise cases with intermittent heating, the results may also be used to derive or validate the associated correction factors for intermittent heating (see 13.2.2).

Note that, mutatis mutandis, similar remarks apply to Equation (I.11) for the cooling mode.

I.3.5 Conversion of monthly to seasonal utilization factors

For the conversion from monthly utilization factors to seasonal utilization factors, the following equations can be used.

For heating:

$$\eta_{H,gn,seas} = (\sum Q_{H,ht,m} - \sum Q_{H,nd,m})/\sum Q_{H,gn,m} \quad (I.13)$$

with $Q_{H,ht,m}$, $Q_{H,nd,m}$ and $Q_{H,gn,m}$ being the monthly values for each month, m , within the fixed length of the heating season, as defined in I.3.6.

ISO 13790:2008(E)

For cooling:

$$\eta_{C,ls} = (\sum Q_{C,gn,m} - \sum Q_{C,nd,m}) / \sum Q_{C,ht,m} \quad (1.14)$$

with $Q_{C,gn,m}$, $Q_{C,nd,m}$ and $Q_{C,ht,m}$ being the monthly values for each month m within the fixed length of the cooling season, as defined in 1.3.6.

It is important to realize that, for calculating the utilization factor for the seasonal method, the season lengths should be **fixed** and not made dependent on the heat-balance ratio. The **actual** length of the season is determined by the utilization factor. For instance, if the fixed length of the heating season is such that in reality a number of months are included without heating needs, then the gain utilization factor will automatically get a low value to compensate the extra solar and internal gains that are introduced in the seasonal heat balance by the months without heating needs.

1.3.6 Seasonal method – fixed length of heating and cooling season

1.3.6.1 Introduction

The fixed length of the heating and cooling seasons is needed for the calculation of total heat transfer and total heat gains during the heating and cooling seasons, as explained in 7.2.1.4.

This length may be determined at national level and its value is not critical, although it should not be too short. The gain utilization factor as a function of the heat-balance ratio (the gain utilization factor curves) depends on the choice of this fixed length. Consequently, the same fixed season length should be used as used for the development of these curves.

Similarly, the fixed length of the cooling season is needed for the calculation of total heat transfer and total heat gains during the cooling season.

1.3.6.2 Fixed length of heating season for the heat balance calculation

The first and last days of the heating season, hence its duration and its average meteorological conditions, can be fixed at national level for a geographic zone and typical buildings. The heating season includes all days for which the heat gains, calculated with a conventional utilization factor, $\eta_{gn,1}$, do not balance the heat transfer; that is when:

$$\theta_{e,day} \leq \theta_{i,set,H,day} - \frac{\eta_{H,gn,1} Q_{gn,day}}{(H_{tr,adj} + H_{ve,adj}) t_{day}} \quad (1.15)$$

where

$\theta_{e,day}$ is the daily average external temperature, expressed in degrees centigrade;

$\theta_{i,set,H,day}$ is the set-point temperature for heating, expressed in degrees centigrade;

$\eta_{H,gn,1}$ is the conventional gain utilization factor calculated with $\eta_H = 1$;

$Q_{gn,day}$ is the daily average internal and solar gains, expressed in megajoules;

$H_{tr,adj}$ is the heat transfer coefficient by transmission, adjusted for the indoor-outdoor temperature difference (if applicable), in accordance with 8.3, expressed in watts per kelvin;

$H_{ve,adj}$ is the heat transfer coefficient by ventilation, adjusted for the indoor-outdoor temperature difference (if applicable), in accordance with 9.3, expressed in watts per kelvin;

t_{day} is the duration of the day, that is 24 h or 0,086 4 Ms.

The heat gains for Equation (I.15) may be derived from a conventional national or regional value of the daily global solar radiation at the limits of the heating season. The monthly average values of daily temperatures and heat gains are attributed to the 15th day of each month. Linear interpolation is used to obtain the limiting days for which Equation (I.15) is verified.

I.3.6.3 Fixed length of cooling season for the heat balance calculation

The first and last days of the cooling season, hence its duration and its average meteorological condition, can be fixed at national level for a geographic zone and typical buildings. The cooling season includes all days for which the (positive) heat transfer, calculated with a conventional utilization factor, $\eta_{C,1}$, does not balance the heat gains.

$$\theta_{e,\text{day}} \geq \theta_{\text{int,set,Cday}} + \frac{Q_{\text{gn,day}}}{\eta_{C,1}(H_{\text{tr,adj}} + H_{\text{ve,adj}}) t_{\text{day}}} \quad (\text{I.16})$$

where

- $\theta_{e,\text{day}}$ is the daily average external temperature, expressed in degrees centigrade;
- $\theta_{\text{int,set,Cday}}$ is the set-point temperature for cooling, expressed in degrees centigrade;
- $\eta_{C,1}$ is the conventional loss utilization factor calculated with $1/\gamma_C = 1$;
- $Q_{\text{gn,day}}$ is the daily average internal and solar gains, expressed in megajoules;
- $H_{\text{tr,adj}}$ is the heat transfer coefficient by transmission, adjusted for the indoor-outdoor temperature difference (if applicable), in accordance with 8.3, expressed in watts per kelvin;
- $H_{\text{ve,adj}}$ is the heat transfer coefficient by ventilation, adjusted for the indoor-outdoor temperature difference (if applicable), in accordance with 9.3, expressed in watts per kelvin;
- t_{day} is the duration of the day, that is 24 h or 0,086 4 Ms.

The heat gains for Equation (I.15) may be derived from a conventional national or regional value of the daily global solar radiation at the limits of the heating season. The monthly average values of daily temperatures and heat gains are attributed to the 15th day of each month. Linear interpolation is used to obtain the limiting days for which Equation (I.15) is verified.

I.4 Relation between overheating and gain utilization factor (heating mode)

The term real heat transfer, meaning the heat transfer that includes the extra heat transfer (see I.2.2) as a result of increased internal temperature (overheating). In this clause more details are given on the aspect of (monthly mean) overheating.

The real loss is equal to:

$$Q_{\text{H,ht,real}} = (H_{\text{tr,adj}} + H_{\text{ve,adj}})(\theta_{\text{int,mn}} - \theta_e)t \quad (\text{I.17})$$

where $\theta_{\text{int,mn}}$ is the real (in contrast to set-point) mean indoor temperature, expressed in degrees centigrade.

The **accumulated overtemperature**, $T_{\text{AO,H}}$, the difference between the real internal temperature and the minimum set-point temperature for heating, summated over all hours of the given period and expressed in kelvin hours, is defined as:

$$T_{\text{AO,H}} = (\theta_{\text{int,mn}} - \theta_{\text{int,H}})t/0,003\ 6 \quad (\text{I.18})$$

ISO 13790:2008(E)

NOTE 1 The term dT_A may be introduced instead of $T_{AO,H}$; dT_A is the “mean overtemperature” ($T_{AO,H} = dT_A \times \text{number of hours}$).

NOTE 2 1/0,003 6 is the conversion from megaseconds to hours.

In the same way, the **relative overtemperature**, $dT_{R,H}$, is by definition the mean real temperature difference between the internal and external environment, divided by the temperature difference based on the minimum set-point temperature.

$$dT_{R,H} = (\theta_{\text{int,mn}} - \theta_e) / (\theta_{\text{int,set,H}} - \theta_e) \quad (1.19)$$

It follows that:

$$Q_{H,\text{ht,real}} = Q_{H,\text{ht}} dT_{R,H} \quad (1.20)$$

$$Q_{H,\text{ht,real}} - Q_{H,\text{ht}} = (H_{\text{tr,adj}} + H_{\text{ve,adj}})[(\theta_{\text{int,mn}} - \theta_e) - (\theta_{\text{int,set,H}} - \theta_e)]t$$

$$Q_{H,\text{ht,real}} - Q_{H,\text{ht}} = (H_{\text{tr,adj}} + H_{\text{ve,adj}})(\theta_{\text{int,mn}} - \theta_{\text{int,set,H}})t$$

$$Q_{H,\text{ht,real}} - Q_{H,\text{ht}} = (H_{\text{tr,adj}} + H_{\text{ve,adj}}) \times 0,003\ 6 \times T_{AO,H} \quad (1.21)$$

In addition, it is evident that the heat that flows over the given period should be in balance, and, consequently, the real loss minus the gains should be equal to the heating demand.

$$Q_{H,\text{dn}} = Q_{H,\text{ht,real}} - Q_{H,\text{gn}} \quad (1.22)$$

Since:

$$Q_{H,\text{nd}} = Q_{H,\text{ht}} - \eta_{H,\text{gn}} Q_{H,\text{gn}}$$

it follows that:

$$Q_{H,\text{ht,real}} - Q_{H,\text{gn}} = Q_{H,\text{ht}} - \eta_{H,\text{gn}} Q_{H,\text{gn}}$$

or

$$Q_{H,\text{ht,real}} - Q_{H,\text{ht}} = Q_{H,\text{gn}} - \eta_{H,\text{gn}} Q_{H,\text{gn}}$$

and so:

$$(H_{\text{tr,adj}} + H_{\text{ve,adj}}) \times 0,003\ 6 \times T_{AO,H} = (1 - \eta_{H,\text{gn}}) Q_{H,\text{gn}} \quad (1.23)$$

Dividing throughout by $Q_{H,\text{ht}}$:

$$dT_{R,H} = \gamma_H (1 - \eta_{H,\text{gn}}) + 1 \quad (1.24)$$

or:

$$dT_{R,H} = (Q_{H,\text{nd}} + Q_{H,\text{gn}}) / Q_{H,\text{ht}} \quad (1.25)$$

which allows conversion between $\eta_{H,\text{gn}}$ and $dT_{R,H}$ and vice versa, which is also convenient in the process of derivation of utilization factor curves. See I.2.

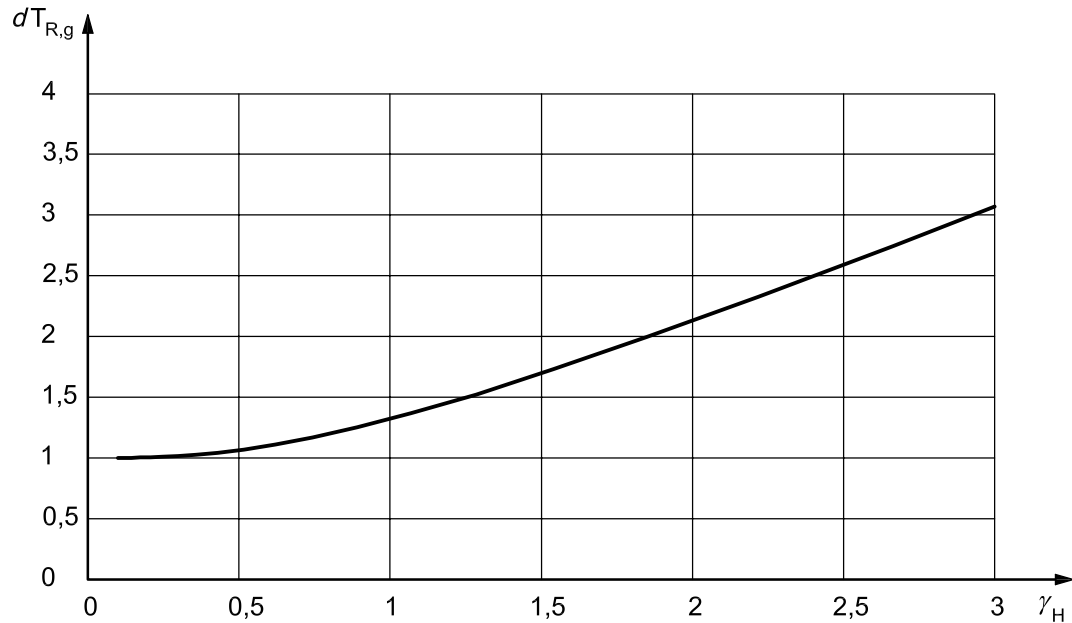

Figure I.1 — Example of curve for the relative overtemperature, $dT_{R,g}$, as a function of gain-loss ratio, γ_H (for $a = 2,12$)

Equation (1.24) indicates that the superfluous heat (left-hand side) is equal to the non-utilized gains (right-hand side). All heat gains that are not utilized lead to a temperature other than the set-point.

The mean temperature rise is therefore:

$$T_{AO,H} = (1/0,003\ 6) (1 - \eta_{H,gn}) Q_{H,gn} / (H_{tr,adj} + H_{ve,adj}) \quad (I.26)$$

The term “superfluous heat” is used instead of the term “overheating”, because it includes the higher temperature that occurs during night-time set-back compared to the situation without gains. The same applies to the use of overtemperature instead of excess temperature.

This is illustrated in Figure I.2.

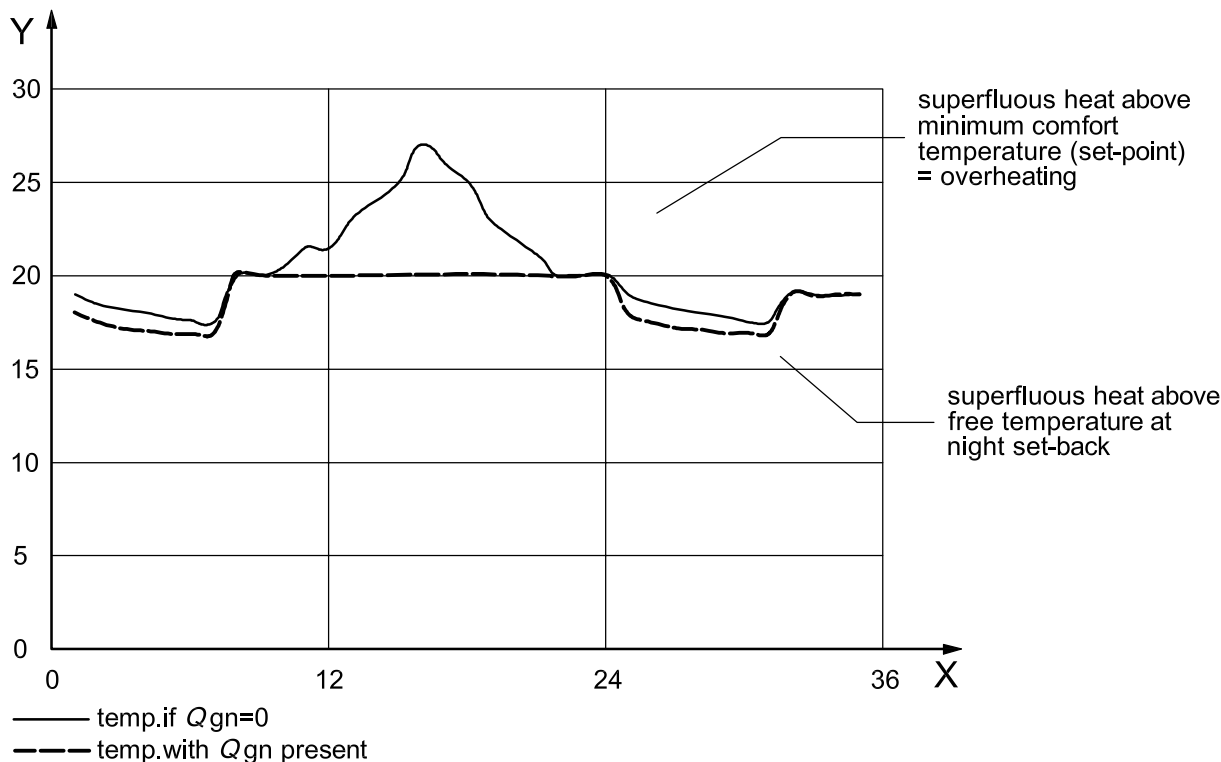
**Key**

- X time in hours
Y internal temperature in degrees centigrade

Figure I.2 — Illustration of daily pattern of indoor temperature with and without heat gains

I.5 Difference with degree-day method

The monthly method in this International Standard is a utilization factor approach in which the monthly energy needs for heating are calculated as the difference between the monthly heat transfer by transmission and ventilation and the monthly sum of gains from internal and solar sources, multiplied by a gain utilization factor. The heating needs are given by:

$$Q_{H,nd} = (H_{tr,adj} + H_{ve,adj}) \sum (\theta_{int,set,H} - \theta_e) - \eta_{H,gn} Q_{H,gn} \quad (I.27)$$

subject to $Q_{H,nd} \geq 0$, where $\theta_{int,set,H}$ is the set-point temperature for heating and θ_e is the external air temperature.

$\sum (\theta_{int,set,H} - \theta_e)$ is equal to $(\theta_{int,set,H} - \theta_{e,mn})t$: the difference between the set-point and monthly average external air temperatures, multiplied by the (total) period length.

If, during a given month, there are intervals with zero energy needs for heating, these are implicitly taken into account by a lower value of the utilization factor.

NOTE This also applies to the seasonal method, with monthly values replaced by seasonal averages.

This approach should not be confused with the degree-day method, such as described in ISO 15927-6^[7], that also uses accumulated temperature differences.

In the degree-day method, the energy needs for heating are calculated without explicitly taking into account the effect of internal and solar gains. This defect is compensated by taking only a subset of the number of days (degree-day method) or hours (degree-hour method) when calculating the heat transfer by transmission and ventilation.

In an equation, for the degree-day method:

$$Q_{H,nd} = (H_{tr,adj} + H_{ve,adj}) \Sigma_{pos}(\theta_{int,base} - \theta_e) \quad (1.28)$$

where Σ_{pos} is the sum over only the days with $-\theta_e < \theta_{int,base}$ and where $\theta_{int,base}$ is a pre-defined temperature, lower than the internal set-point temperature. This reduction in temperature difference and the reduction in the number of days are needed because the (utilized) internal and solar gains are disregarded in the equations. Note, however, that the reduction is a reduction without knowledge of the specific heat-balance ratio (ratio between gains and heat transfer). This shows that the degree-day method is a more approximate and simple method compared to the utilization factor method.

In summary:

- in the utilization factor method, all hours of the month considered are included in the calculation of the accumulated temperature difference;
- no distinction is made between days or hours with external temperature higher or lower than a certain base temperature as in a degree-day method;
- the internal temperature is defined by the set-point temperature and not by a base temperature as in a degree-day method.

For the cooling mode, a similar reasoning applies.

Annex J (informative)

Worked example; simple hourly and monthly methods

J.1 Scope and background of example

Test case 6 in EN 15265:2007, is used as an example. Most input data are copied exactly as is described in EN 15265. It is therefore possible that some input data are not representative of common situations, because the test cases are only intended as simplified cases and only to validate dynamic simulation methods.

The purpose of this annex is to give an example of how the main equations in this International Standard for the calculation of the energy use for space heating and cooling by the simple hourly and monthly methods are used. Because of the nature and purpose of the example, not all the input data and justifications are presented in accordance with the reporting requirements given in Clause 15. In relation to this, the example does not contain an error analysis.

J.1.1 Building dimensions

The test cases of EN 15265 consist of the room of an office building.

The internal dimensions of the room are: length = 3,6 m; depth = 5,5 m; height = 2,8 m. The external wall including window glazing is facing west. The areas of the components of the reference room are given in Table J.1. The cases do not include a ground floor.

Table J.1 — Areas of reference room components, area in square metres

External wall (including window)	Window glazing	Internal wall left	Internal wall right	Internal wall back	Floor	Ceiling
10,08	7,0	15,4	15,4	10,08	19,8	19,8

J.1.2 Transmission characteristics

The heat transfer coefficient by transmission, $H_{tr,adj}$, of the construction adjacent to the external environment is 18,2 W/K, both for the heating and cooling calculation.

For the other constructions, a situation of thermal balance is assumed, so these construction parts (floor, ceiling and internal walls) are not taken into account in the calculation for thermal transmission.

The example does not take into account thermal bridges.

J.1.3 Ventilation characteristics

The office is ventilated with a ventilation rate of 1,0 air changes per hour from 08:00 to 18:00 during weekdays.

For the monthly method, it is taken into account that this is a case with heating and cooling interrupted during the weekends. The different ventilation schedule for the weekend is not explicitly included, because the calculation of the effect of the intermittency applies the reduction factor on the monthly energy need for heating and cooling, according to 13.2.2.

For the weekdays, the time fraction, $f_{ve,t}$, during which the ventilation is present is 0,417 and, consequently, the heat transfer coefficient, $H_{ve,adj}$, by ventilation with external air is 7,7 W/K.

The supply temperature of the ventilation air, θ_{sup} , is the external temperature, θ_{e} , as given in J.1.8, so $b_{\text{ve}} = 1$.

Infiltration is not taken into account.

J.1.4 Solar heat gain characteristics

The external façade is oriented towards the west. There are no obstacles.

The opaque area of the façade is 3,08 m² with a g -value of 0,012 (absorption coefficient for solar radiation is 0,6, external surface heat resistance is 0,04 m²K/W and thermal transmittance of opaque façade is 0,493 W/m²K).

The façade has 7 m² of windows with no solar shading. The g -value of the glazing is 0,20; window frames are ignored.

The effective collecting area of the façade, $A_{\text{s},k}$, is 1,40 m².

The solar irradiance, $I_{\text{sol},k}$, the time-average energy of the solar irradiation over the calculation period, per square metre of collecting area of the facade with the given orientation, is given in J.1.8.

The extra heat flow due to thermal radiation to the sky from the building is not taken into account in these test cases.

J.1.5 Internal heat gains

The internal gains are 20 W/m² from 08:00 to 18:00 from Monday to Friday. Outside this period no internal gains are present.

For the monthly method, it is taken into account that this is a case with heating and cooling interrupted during the weekends. The different internal heat gains schedule for the weekend is not explicitly taken into account, because the calculation of the effect of the intermittency applies the reduction factor on the monthly energy need for heating and cooling, according to 13.2.2.

For the weekdays, the time-average heat flow rate from internal heat, $\Phi_{\text{int,mn}}$, is 165 W.

J.1.6 Building time constant

The mass of the building is heavy. The internal capacity is calculated using the simplified procedure from Annex A of ISO 13786:2007, without surface resistance correction. The value is 355 000 J/(m²K). This is close to the class "very heavy" in Table 12. This makes the internal capacity $C_{\text{m}} = 7\,030\,000$ J/K.

For the monthly method, the value for the dimensionless reference numerical parameter, α_0 , for heating and cooling is taken from Table 9 and Table 10 and is 1 for both situations. The value for the reference time constant, τ_0 , for heating and cooling is also taken from Table 9 and Table 10 and is 15 h for both situations.

J.1.7 Use of the building

The building is used from 08:00 to 18:00 from Monday to Friday (intermittent heating and cooling).

Only during this period are the heating, cooling and ventilation in operation.

The set-point for heating, $\theta_{\text{int,H,set}}$, is 20 °C, the set-point for cooling, $\theta_{\text{int,C,set}}$, is 26 °C.

For the monthly method, the fraction of the number of hours in the week with a normal heating set-point, $f_{\text{H,hr}}$, is 0,3. The fraction of the number of days in the week with a normal cooling set-point, $f_{\text{C,day}}$, is 0,7.

There are no unoccupied periods (e.g. no summer holidays where the building is closed).

J.1.8 Climate data

Climate data for Paris are used. The monthly values are shown in Table J.2. The hourly climate data can be found in EN 15265.

Table J.2 — Climate data

Month	External temperature	Solar radiation on west-facing wall	Period duration
	θ_e °C	I_{sol} W/m ²	t Ms
January	3,2	20	2,678
February	4,8	37	2,419
March	6,3	85	2,678
April	7,8	82	2,592
May	13,0	99	2,678
June	15,4	117	2,592
July	18,3	125	2,678
August	17,0	92	2,678
September	14,9	68	2,592
October	10,1	44	2,678
November	5,4	21	2,592
December	4,2	17	2,678

J.2 Calculation results, simple hourly method

Table J.3 shows the input and the main output of the simple hourly method for the given case.

Table J.3 — Calculation of energy need for heating and cooling, simple hourly method (in kWh)

Simple hourly method				Case CEN 6										
Inputs														
H window	16,6	W/K	floor area	19,8	m ²	N E S W H								
H opaque	1,51	W/K				solar aperture								
inertia	4	(1: very light to 5: very heavy)				0	0	0	1,44	0	m ²			
ventilation	day	night												
	55,4	0	m ³ /h											
internal gains	396	0	W											
set-point heating	20	-100	°C											
set-point cooling	26	100	°C											
Per floor area, for information														
H window	0,84	W/(K·m ² of floor area)	N E S W H											
H opaque	0,08	W/(K·m ² of floor area)	solar ratio											
ventilation	day	night												
	2,8	0	m ³ /(h·m ²)											
internal gains	20	0	W/m ²											
Monthly and yearly results														
	1	2	3	4	5	6	7	8	9	10	11	12	year	
heating	137	91	40	25	0	0	0	0	0	20	102	120	537	kWh
cooling	0	0	0	0	-5	-37	-82	-44	-8	0	0	0	-177	kWh
internal gains	91	79	87	83	91	83	87	91	79	91	87	83	1034	kWh

J.3 Calculation results, monthly method

The calculation of the energy need for heating for each month is given in Table J.4.

Table J.4 — Calculation of energy need for heating, monthly method (in kWh)

Month	$Q_{H,tr}$ kWh	$Q_{H,ve}$ kWh	$Q_{H,ht}$ kWh	$Q_{H,sol}$ kWh	$Q_{H,int}$ kWh	$Q_{H,gn}$ kWh	γ_H	$\eta_{H,gn}$	$a_{red,H}$	$Q_{H,nd}$ kWh
Jan.	227	96	324	21	123	144	0,44	0,996	0,81	147
Feb.	186	79	265	36	111	147	0,63	0,987	0,77	92
Mar.	186	78	264	91	123	214	1,00	0,931	0,66	43
Apr.	160	68	228	85	119	204	1,57	0,901	0,63	28
May	95	40	135	106	123	229	3,15	0,580	0,30	1
June	60	26	86	121	119	240	6,11	0,357	0,30	0
July	23	10	33	134	123	256	8,78	0,128	0,30	0
Aug.	41	17	58	98	123	221	7,96	0,261	0,30	0
Sep.	67	28	95	70	119	189	3,58	0,499	0,30	0
Oct.	134	57	191	47	123	170	1,32	0,902	0,63	24
Nov.	191	81	272	22	119	141	0,58	0,991	0,78	104
Dec.	214	91	304	18	123	141	0,40	0,995	0,81	132
Total										571

Even in the months with the highest energy need for heating, the energy need is a small difference between two large numbers ($Q_{H,ht}$ and $Q_{H,gn}$, the latter multiplied by the utilization factor $\eta_{H,gn}$ and the result reduced for intermittency with $a_{red,H}$). This means that the result is sensitive for minor differences in assumptions.

The calculation of the energy need for cooling for each month is given in Table J.5.

Table J.5 — Calculation of energy need for cooling, monthly method (in kWh)

Month	$Q_{C,tr}$ kWh	$Q_{C,ve}$ kWh	$Q_{C,ht}$ kWh	$Q_{C,sol}$ kWh	$Q_{C,int}$ kWh	$Q_{C,gn}$ kWh	γ_C	$\eta_{C,gn}$	$a_{red,C}$	$Q_{C,nd}$ kWh
Jan.	309	131	439	21	123	144	0,33	0,328	0,94	0
Feb.	259	110	369	36	111	147	0,40	0,396	0,93	0
Mar.	267	113	380	91	123	214	0,56	0,555	0,90	3
Apr.	238	101	339	85	119	204	0,60	0,589	0,89	3
May	176	74	251	106	123	229	0,91	0,816	0,84	20
June	139	59	198	121	119	240	1,21	0,926	0,78	44
July	104	44	148	134	123	256	1,73	0,984	0,70	77
Aug.	122	52	173	98	123	221	1,27	0,939	0,77	45
Sep.	145	62	207	70	119	189	0,91	0,816	0,84	17
Oct.	215	91	306	47	123	170	0,55	0,547	0,90	2
Nov.	270	114	384	22	119	141	0,37	0,365	0,93	0
Dec.	295	125	420	18	123	141	0,34	0,335	0,94	0
Total										213

Even in the months with the highest energy need for cooling, the energy need is a small difference between two large numbers ($Q_{C,gn}$ and $Q_{C,ht}$, the latter multiplied by the utilization factor $\eta_{C,gn}$ and the result reduced for intermittency with $a_{red,C}$). This means that the result is sensitive for minor differences in assumptions.

Annex K (informative)

Flow charts of the calculation procedures

K.1 Scope

The main terms of the time-averaged energy balance for heating and cooling are illustrated schematically in the following clauses, for heating and cooling separately. First, a simple situation is presented, followed by a detailed version where all possible energy flows are shown.

K.2 Heating mode, simple situation

See Clause 4 for the symbols and subscripts.

Explanation, building part:

- Heat balance:
 - the energy need for heating is given by the difference between the transmission and ventilation heat transfer (heat losses) and the heat gains from solar and internal sources;
 - the diagram is valid for steady state: the heat balance is taken over a sufficiently long time to ignore heat stored and released (typically: one month or a whole season);
 - by convention, the transmission and ventilation heat transfer, $Q_{ht} = Q_{tr} + Q_{ve}$, is calculated on the basis of the intended minimum internal temperature, the **set-point temperature**;
 - the **actual time-averaged (mean) internal temperature** can be higher, due to instantaneous overheating; consequently, the actual heat losses calculated (or measured) from this actual mean internal temperature are also higher than those calculated on the basis of the set-point temperature; this is represented by the term ΔQ_{tr+ve} ;
 - note that for the monthly or seasonal “utilization factor” method this ΔQ_{tr+ve} is equal to the non-utilized part of the solar and internal heat gains $(1 - \eta_{H,gn})Q_{gn} = \Delta Q_{tr+ve}$; this gives the basic equation: $Q_{H,nd} = Q_{ht} - \eta_{H,gn} \times Q_{gn}$.
- Explicitly shown is the heat loss from the heating system that is recovered in the building as part of the internal heat gains. In this International Standard, the internal heat gains comprise recoverable heat from other technical building systems and appliances and metabolic heat from persons.

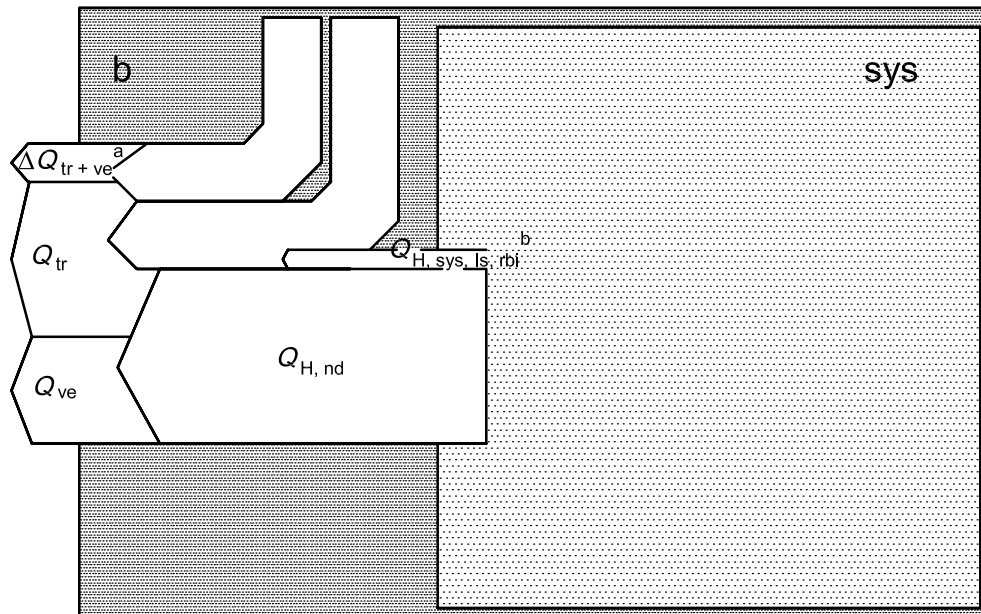

Key

- ^a See Explanation.
^b Heat recovered in the building, coming from heating system losses (e.g. from hot pipes).

Figure K.1 — Energy balance, building part — Heating mode; simple situation

Explanation, system part:

- The energy need for heating the building is covered by the heating system output (resource energy), with additional output from a solar heating system (renewable energy).
- The system losses are partly recovered in the building, as shown in Figure K.2.
- System losses that are recovered within the system are not shown in this diagram; they would appear as a loop within the system: losses going out and coming in again.
- The delivered energy may consist of different energy carriers that each have to be counted separately. Electric energy is shown explicitly, because that is often the second energy carrier (e.g. for auxiliary energy).

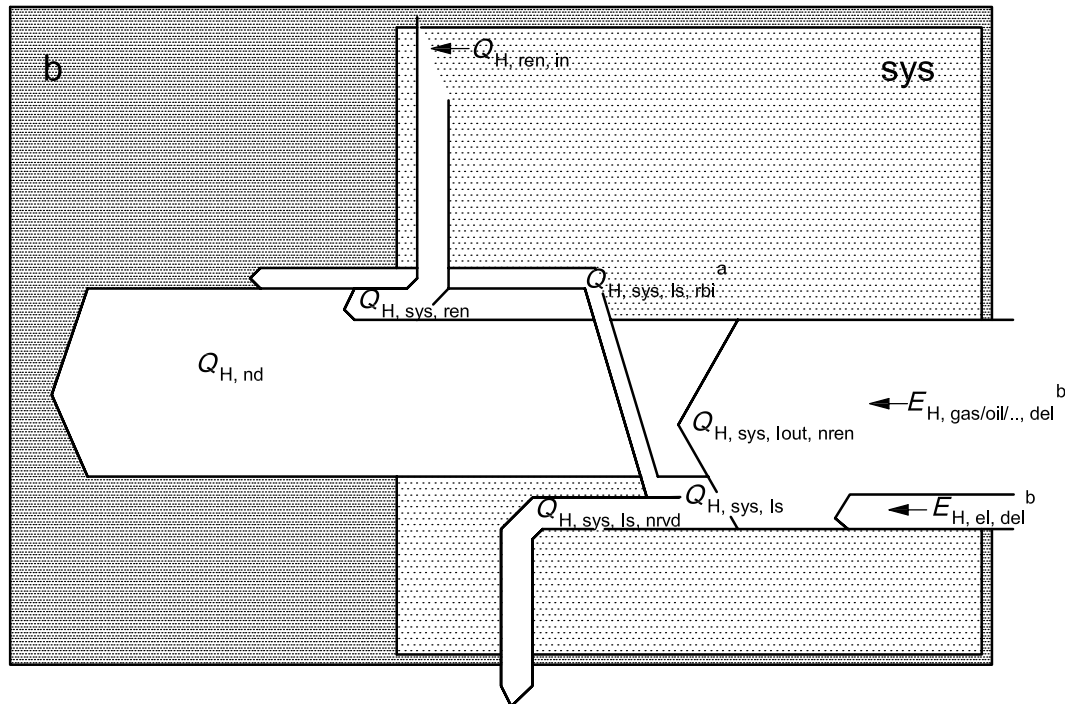

Key

- a Heat recoverable in the building, coming from heating system losses.
- b Per energy carrier.

Figure K.2 — Energy balance, system part — Heating mode; simple situation

K.3 Heating mode, detailed situation

See Clause 4 for the symbols and subscripts.

Explanation, building part:

- Two elements have been added compared to the simple case:
 - heat recovery of ventilation heat losses ($Q_{V,sys,ls,rvd}$); part of the heat loss by ventilation is recovered in a heat recovery unit (pre-heat of the supply air); this is a typical example of the interaction between the **building** and the **system**;
 - another example of such interaction, but less common, is heat recovered in the **system**, coming from **building** losses ($Q_{V,b,ls,rvd}$), for instance heat recovered from the building construction which is used in the ventilation system (e.g. trombe wall or dynamic thermal insulation, if connected to ventilation system).

NOTE This type of interaction is more common for cooling: pre-cooling of ventilation air via cool building construction; not shown in the diagrams for cooling to avoid too high complexity.

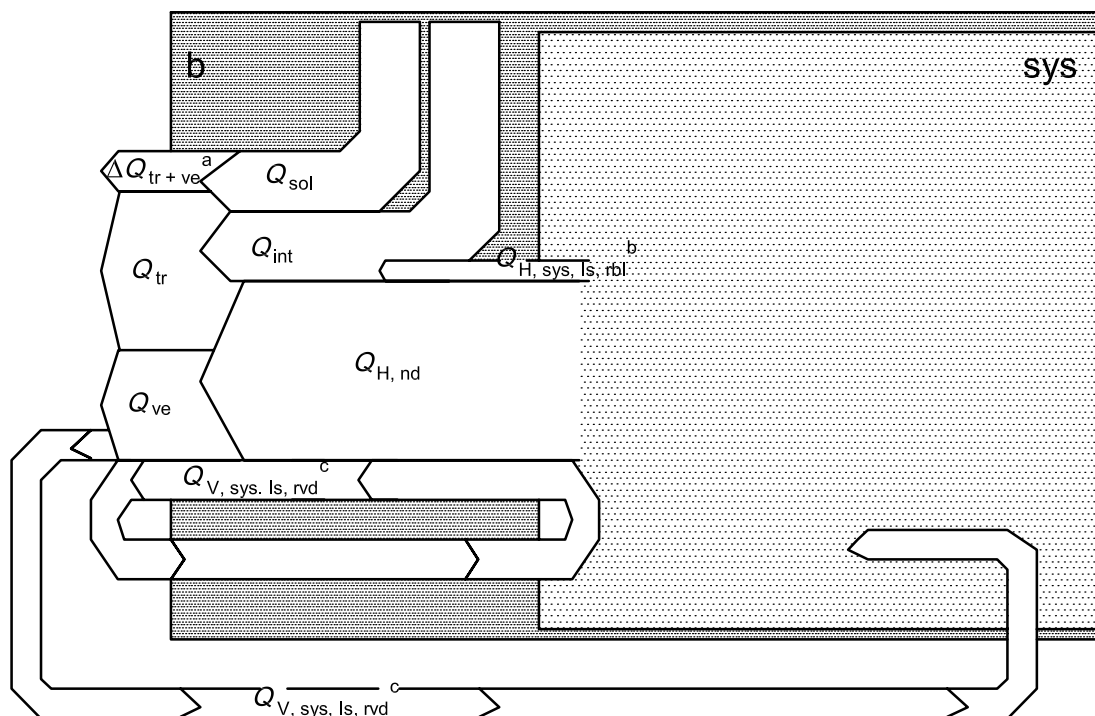

Key

- a See Explanation.
- b Heat recovered in the building, coming from heating system losses (e.g. from hot pipes).
- c Heat recovered in the ventilation system, from ventilation losses (heat recovery unit).
- d Heat recovered in the system, coming from building losses (e.g. heat recovered from building construction to ventilation system).

Figure K.3 — Energy balance, building part — Heating mode; all possible flows

Explanation, system part:

- The same two additional elements as for Figure K.3 are included with the interaction between system and building.
- Several elements have been added to the system compared to the simple case.
- Renewable electricity, e.g. to be used as auxiliary energy.
- Export of heat and electricity, from the (non-renewable) resources and from the renewable energy sources; note that the subscript for the energy use (H) has been deleted (it is not relevant or even unknown for which use the heat or electricity is exported).
- The heating system may also use heat from other systems (e.g. recovered losses), in this case illustrated by input from the hot water system ($Q_{W,sys,ls,rvd}$).
- System losses that are recovered within the system are not shown in this diagram; they would appear as a loop within the system; losses going out and coming in again.

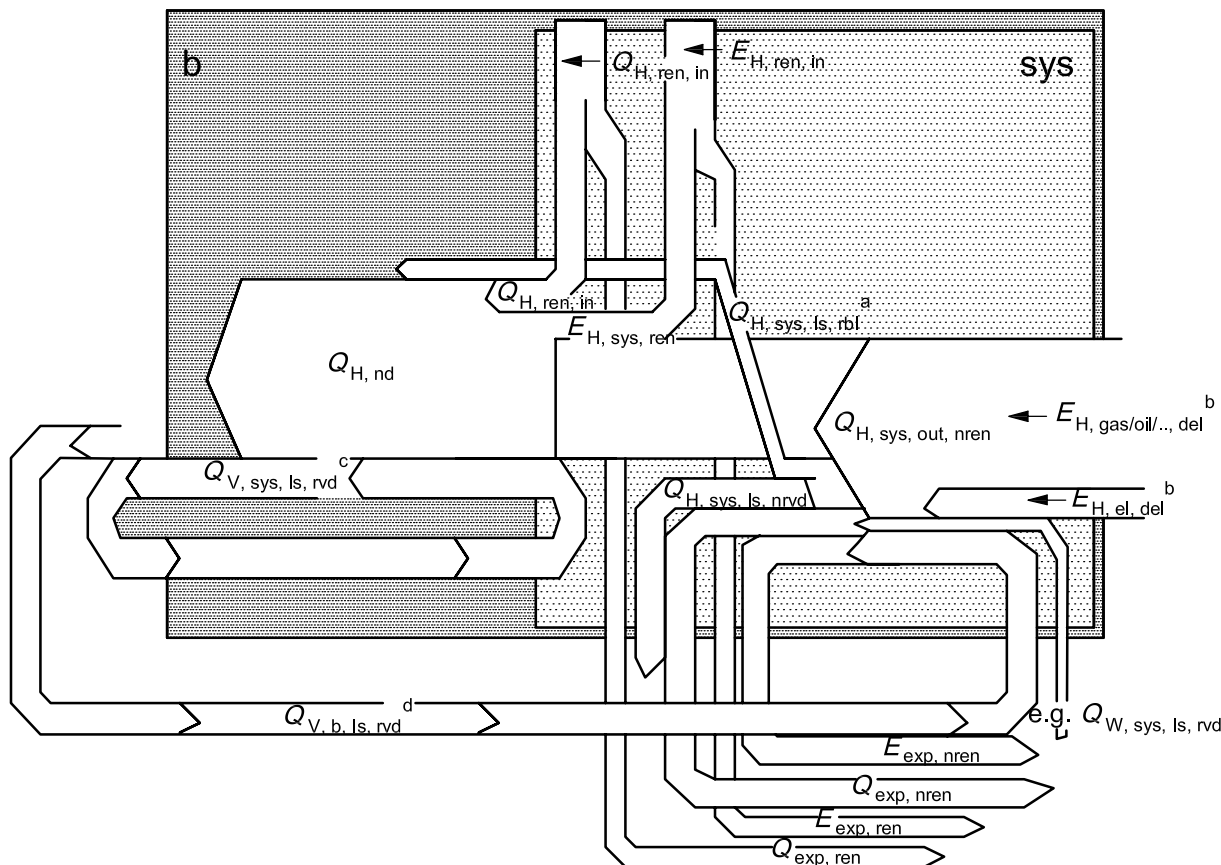

Key

- a Heat recovered in the building, coming from heating system losses (e.g. from hot pipes).
- b Per energy carrier.
- c Heat recovered in the ventilation system, from ventilation losses (heat recovery unit).
- d Heat recovered in the system, coming from building losses (e.g. heat recovered from building construction to ventilation system).

Figure K.4 — Energy balance, system part — Heating mode; all possible flows

K.4 Cooling mode, “medium” case

See Clause 4 for the symbols and subscripts.

Explanation, building part:

- Because cooling is included, the energy need arrow is pointing outward – heat extracted from the building by the cooling system.
- Heat balance:
 - the energy need for cooling is given by the difference between the transmission and ventilation heat transfer (heat losses) and the heat gains from solar and internal sources;
 - the diagram is valid for steady state: the heat balance is taken over a sufficiently long time to ignore heat stored and released (typically one month or a whole season);

- by convention, the transmission and ventilation heat transfer, $Q_{ht} = Q_{tr} + Q_{ve}$, is calculated on the basis of the intended maximum internal temperature, the **set-point temperature**;
 - the **actual time-average (mean) internal temperature** may be lower, due to instances with lower temperatures than the set-point; consequently, the actual heat losses calculated (or measured) from this actual mean internal temperature are also lower than those calculated on the basis of the set-point temperature; this is represented by the term $-\Delta Q_{tr+ve}$;
 - note that, for the monthly or seasonal “utilization factor” method, this ΔQ_{tr+ve} is equal to the “non-utilized” part of the heat losses by transmission and ventilation, $\eta_{C,ls} Q_{ht} = \Delta Q_{tr+ve}$; this gives the basic equation: $Q_{C,nd} = Q_{gn} - \eta_{C,ls} Q_{ht}$.
- Explicitly shown is the heat loss from the cooling system that is recovered in the building: the cold parts of the distribution system can lead to a negative heat source (heat sink) which is taken into account as a negative term in the internal heat gains.

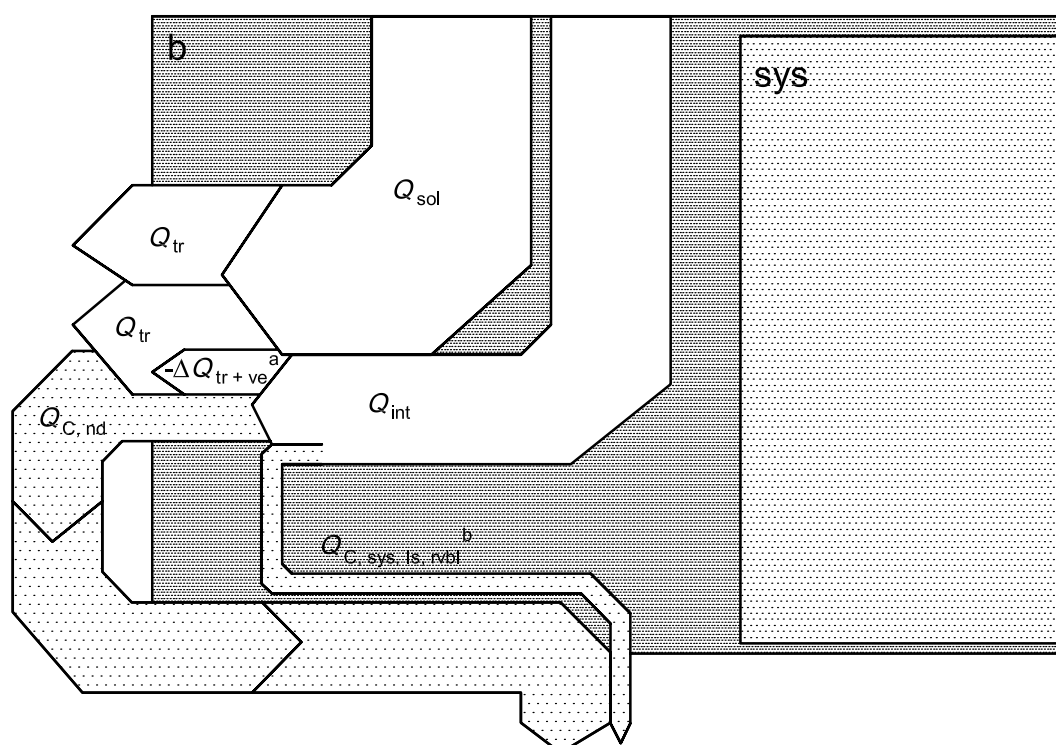

Key

- a See Explanation.
- b Cold recovered in the building, coming from the cooling system losses (e.g. from cold pipes).

Figure K.5 — Energy balance, building part — cooling mode, “medium” case with respect to complexity

Explanation, system part:

- the cooling system consists of an “energy supply” part (blank arrows, usually “warm”) and a cold part (dotted arrows);
- for evident reasons, the losses in the warm part shall be distinguished from the losses in the cold part;
- the system shall supply energy to cover the energy need for cooling, plus the non-recovered losses and the losses recovered in the building (see Figure K.6), plus exported cold (if any);

- the supplied energy can be thermal (renewable heat, gas, oil) and/or electric (renewable, resources);
- the delivered energy may consist of different energy carriers that have to be counted separately; electrical energy is shown explicitly because that is often the second energy carrier (e.g. for auxiliary energy); shown separately are $EC_{el,del}$ and $EC_{gas/oil/...,del}$ to emphasise this;
- system losses that are recovered within the system are not shown in this diagram; they would appear as a loop within the system: losses going out and coming in again.

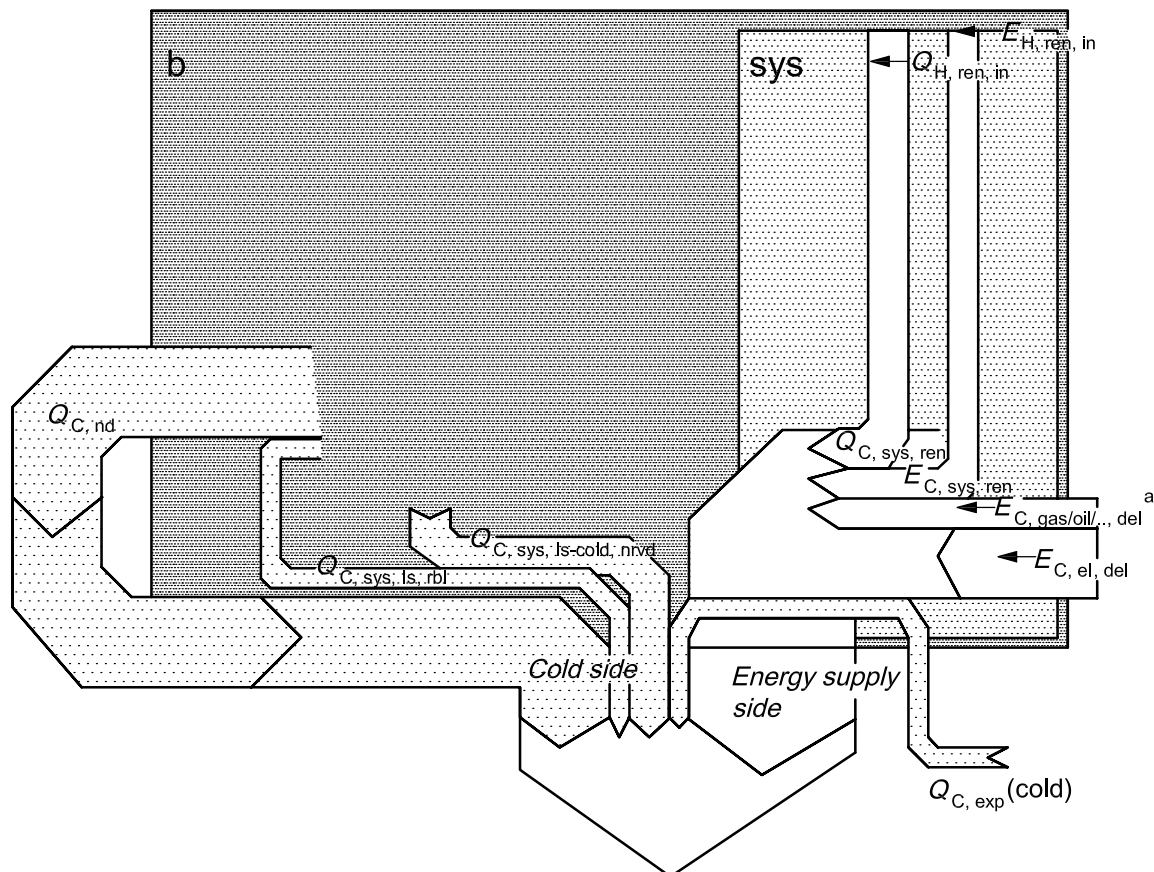

Key

- a Per energy carrier.

Figure K.6 — Energy balance, system part — cooling mode, “medium” case with respect to complexity

Bibliography

- [1] ISO 7726, *Ergonomics of the thermal environment — Instruments for measuring physical quantities*
- [2] ISO 9050 *Glass in building — Determination of light transmittance, solar direct transmittance, total solar energy transmittance, ultraviolet transmittance and related glazing factors*
- [3] ISO 9488, *Solar energy — Vocabulary*
- [4] ISO 10077-2, *Thermal performance of windows, doors and shutters — Calculation of thermal transmittance — Part 2: Numerical method for frames*
- [5] ISO 15099, *Thermal performance of windows, doors and shading devices — Detailed calculations*
- [6] ISO 15927-1, *Hygrothermal performance of buildings — Calculation and presentation of climatic data — Part 1: Monthly means of single meteorological elements*
- [7] ISO 15927-6, *Hygrothermal performance of buildings — Calculation and presentation of climatic data — Part 6: Accumulated temperature differences (degree days)*
- [8] EN 12831, *Heating systems in buildings — Method for calculation of the design heat load*
- [9] EN 15232, *Energy performance of buildings — Impact of building Automation, Controls and Building Management*
- [10] EN 15251, *Indoor environmental input parameters for design and assessment of energy performance of buildings addressing indoor air quality, thermal environment, lighting and acoustics*
- [11] EN 15265:2007, *Energy performance of buildings — Calculation of energy needs for space heating and cooling using dynamic methods — General criteria and validation procedures*
- [12] EN 15316-4-5, *Heating systems in buildings — Method for calculation of system energy requirements and system efficiencies — Part 4-5: Space heating generation systems, the performance and quality of district heating and large volume systems*
- [13] PASSYS, *Final Report of the Simplified Design Tool Subgroup*, Commission of the European Communities, Directorate General XII, EUR 12 998 EN, Brussels, 1989
- [14] Règles ThG, *Règles de calcul du coefficient GV des bâtiments d'habitation et du coefficient G1 des bâtiments autres que d'habitation*, Cahiers du CSTB 2256, Paris, 1988
- [15] Règles ThBV, *Règles de calcul du coefficient de besoins de chauffage des logements*, Cahiers du CSTB 2486, Paris, 1991
- [16] Règles ThBV, *Règles de calcul du coefficient de besoins de chauffage des logements — Annexes*, Cahiers du CSTB 2274, Paris, 1988
- [17] Règles ThC, *Règles de calcul du coefficient de performance thermique globale des logements*, Cahiers du CSTB 2259, 1988, Paris.
- [18] Règles ThC, *Règles de calcul du coefficient de performance thermique globale des logements. Compléments et annexes*, Cahiers du CSTB 2275, Paris, 1988
- [19] SIA 380-1, *Energie im Hochbau – Énergie dans le bâtiment*, SIA, Zürich, 1988

ISO 13790:2008(E)

- [20] PLATZER, W.J. *Energetische Bewertung der transparenten Wärmedämmung*, Bauphysik, **Heft 2/99**, pp 67-76, 1999
- [21] *Richtlinie Bestimmung des solaren Energiegewinns durch Massivwände mit transparenter Wärmedämmung*, Fachverband Transparente Wärmedämmung e.V., Gundelfingen, Germany, 1999
- [22] Van DIJK, H.A.L. and ARKESTEIJN, C.A.M. *Windows and Space Heating Requirements; parameter studies leading to a simplified calculation method*, The Netherlands national report within Step 5 in IEA ECBCS Implementing Agreement project "Annex XII, Windows and Fenestration", Delft, December 1987
- [23] PASSYS-II, *Research Report of the Simplified Design Tool Subgroup*, Commission of the European Communities, Directorate General XII, Contract JOUE-CT90-0022, Brussels, September 1993
- [24] Van DIJK, H.A.L. and SPIEKMAN, M.E. *Energy Performance of Buildings; Outline for Harmonised EP Procedures*. Final report of EU ENPER project, Task B6. Contract SAVE 4. 1031/C/00-018 TNO Building and Construction Research, Delft, The Netherlands, June 29, 2004; (<http://www.enper.org>)
- [25] Van DIJK, H.A.L., SPIEKMAN, M.E. and DE WILDE, P. *A monthly method for calculating energy performance in the context of European building regulations*, Proceedings of the Building Simulation 2005 Conference, Montreal, August 2005
- [26] EPBD, Directive 2002/91/EC of the European Parliament and of the Council of 16 December 2002 on the energy performance of buildings
- [27] PEREZ, R., SEALS, P., INEICHEN, R., STEWART, R. and MENICUCCI, D. *A new simplified version of the Perez diffuse irradiance model for tilted surfaces*, Solar Energy, **39**, (3), pp. 221-231, 1987
- [28] CEN/TR 15615, *Explanation of the general relationship between various CEN standards and the Energy Performance of Buildings Directive (EPBD)*

ICS 91.120.10

Price based on 162 pages