



Aalto University
School of Engineering

MEC-E5003

FLUID POWER BASICS

Study Year 2018 - 2019

Pumps

Actuators

Accumulators



Aalto University
School of Engineering
Mechanical Engineering / Engineering Design / Mechatronics / Fluid Power

Lecture themes

Flow to the system – How?

Making use of the hydraulic power – How?

Storing energy in hydraulic system – Why and is that even possible?

Hydrostatic pumps

Convert mechanical power into hydraulic power

Hydrostatic pumps produce flow, not pressure

Unidirectional

Bidirectional



Constant displacement

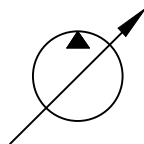

Variable displacement

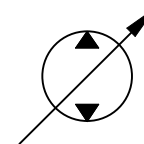

Construction

Most common construction types:

- gear
- vane
- screw
- piston

All operate on positive displacement principle

Positive displacement principle

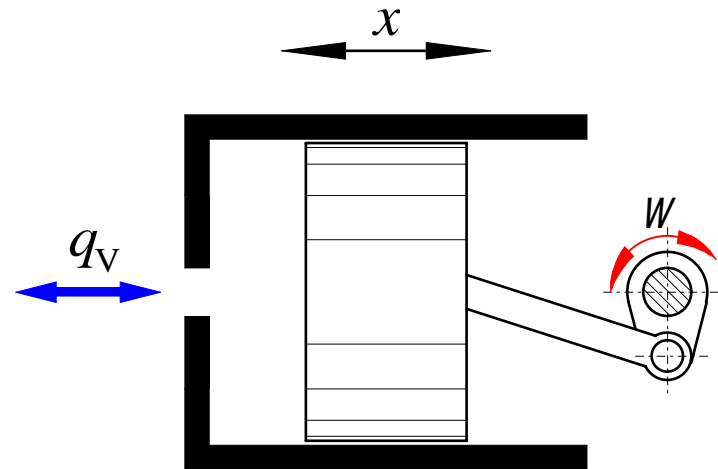

Operating phases:

Fluid flows into transfer volume – suction phase

Fluid flows out from volume – pressure phase

Control of flow direction

Check valves

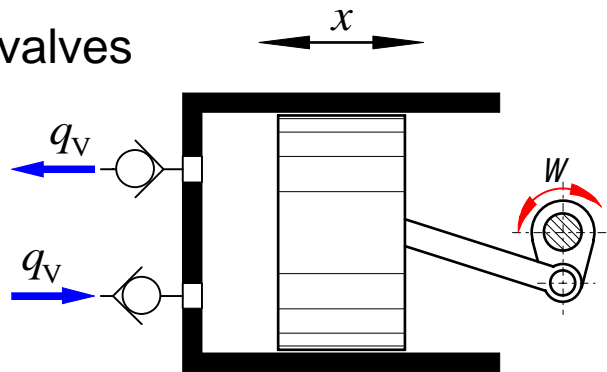

Pressure control
aka valve control

Forced control ®

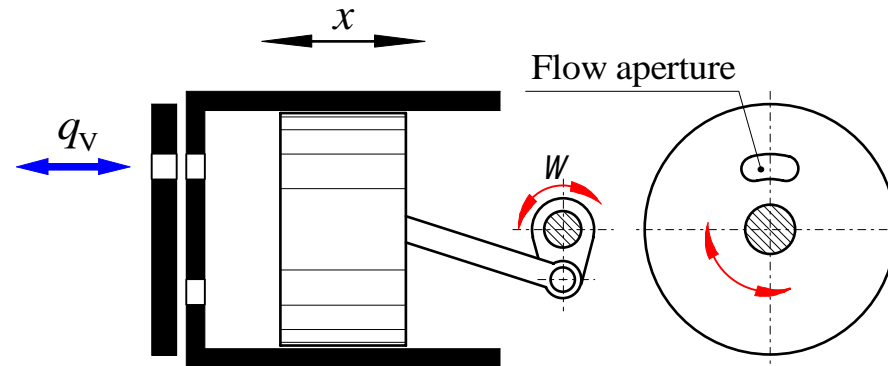

Pressure control aka valve control

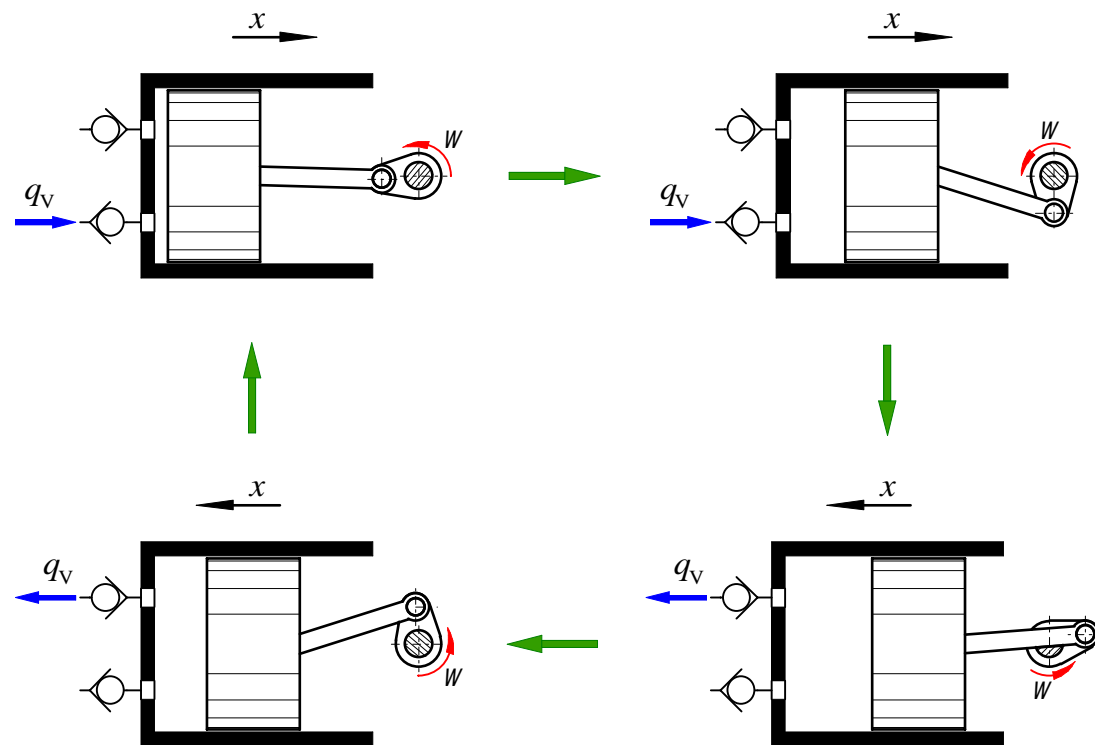

Forced control

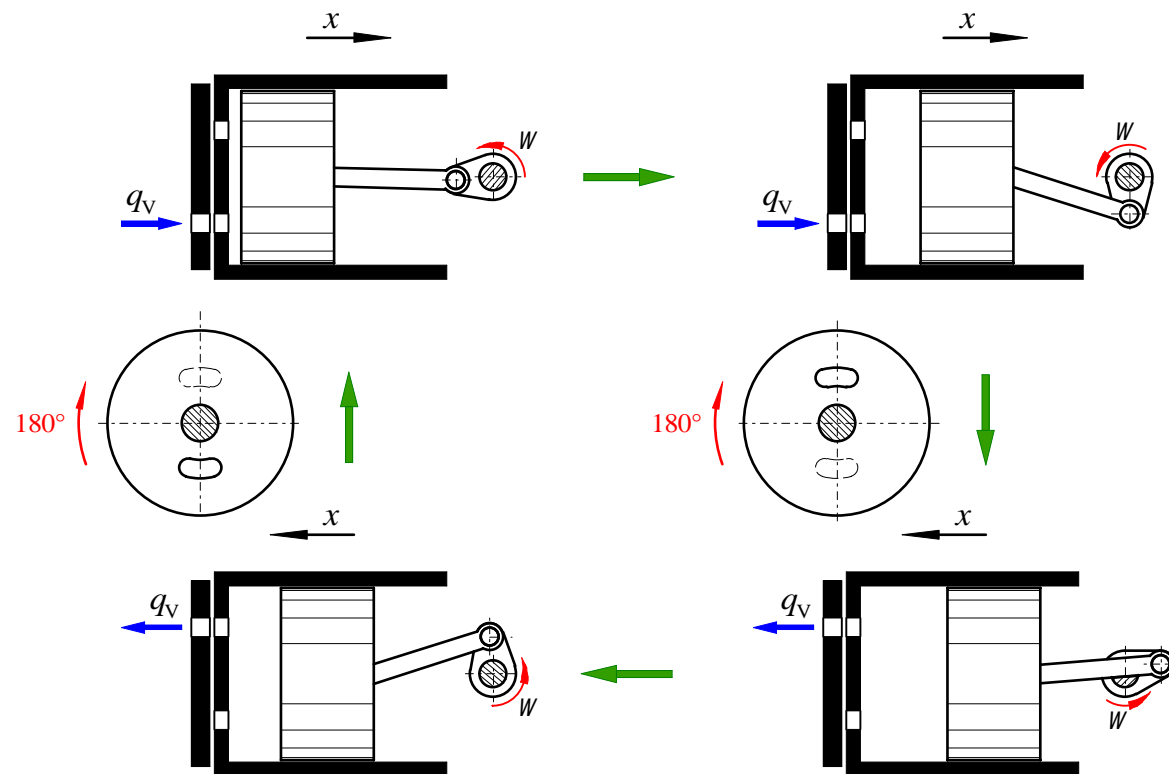

Output flow variation ->
Internal pressure variation (depending
on the system impedance) ->

Flow pulsation External (air) pressure variation -> Noise

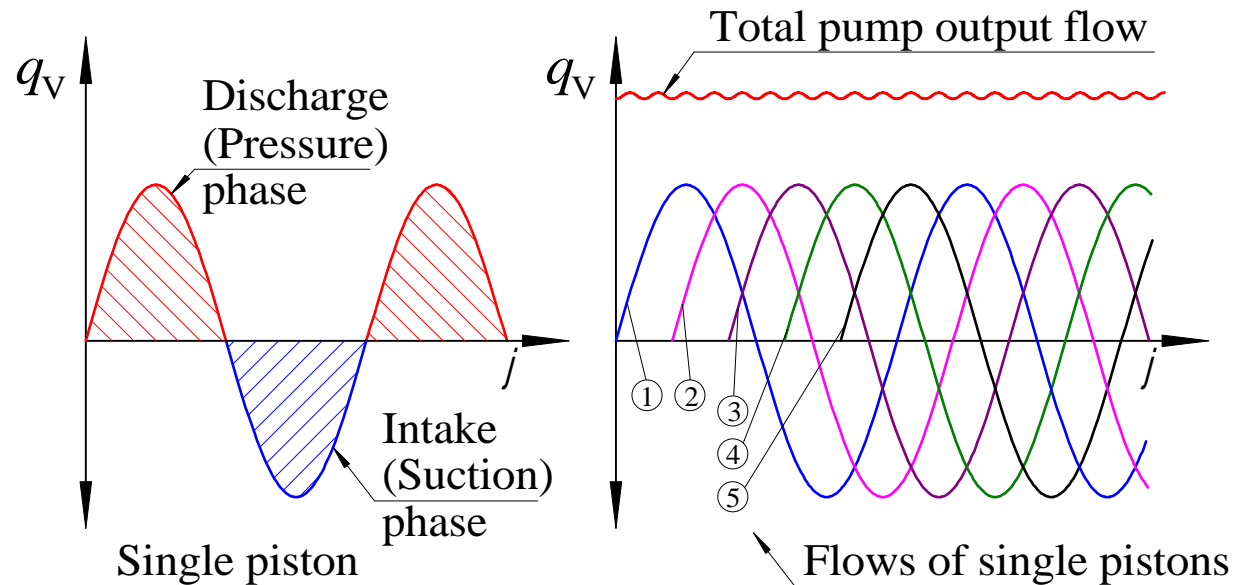

Flow pulsation is due to intermittent
nature of positive displacement principle

Cavitation in pumps

Cause: Friction losses in inlet channel of pump

Pressure in fluid decreases to vapour pressure of the fluid

Ⓜ fluid starts to vaporize (also size of air bubbles increases)

Ⓜ vaporized fluid is pressurized in pump

Ⓜ vapour bubbles collapse rapidly ("implosion")

Ⓜ pressure shocks

Ⓜ material damages, noise, decreased output flow

Suction lines of pumps are

- short

- straight

- wide (large diameter) and the pump can be placed lower than the reservoir (tank) surface to avoid cavitation.



Aalto University

School of Engineering

Mechanical Engineering / Engineering Design / Mechatronics / Fluid Power

Pump characteristics

Theoretical output flow $q_{V,\text{theor}} = n \times V_g$

Swept volume V_g [m³/r]

$$\text{cm}^3/\text{r} = 10^{-6} \text{ m}^3/\text{r}$$

Rotation speed n [r/s]

$$\text{r/min} = 1/60 \text{ r/s}$$

$$q_{V,\text{theor}} = \omega \times V_{\text{rad}}$$

$$\omega = 2\pi \times n$$

Angular velocity ω [rad/s]

$$V_{\text{rad}} = \frac{V_g}{2\pi}$$

Swept volume per radian V_{rad} [m³/rad]

Effective output flow

$$q_{V,\text{real}} = n \times V_g \times h_v$$

Leakage – volumetric efficiency h_v

Wilson's pump model

$$q_{V2} = \varepsilon V_i n - C_s \frac{V_i \Delta p}{2\pi \nu \rho}$$

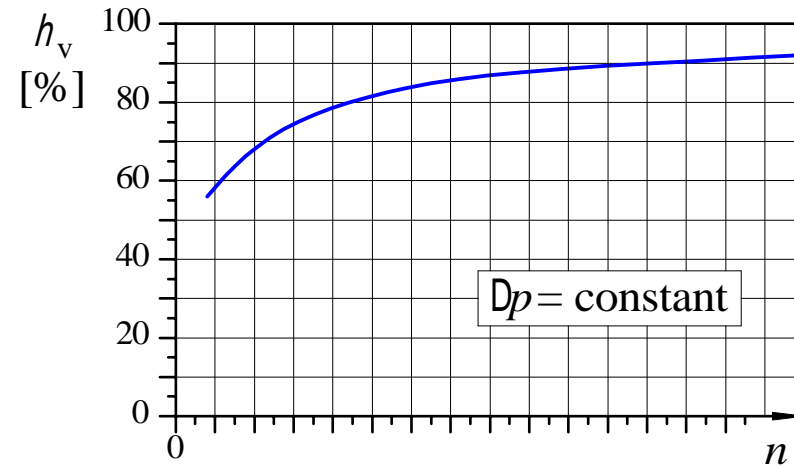
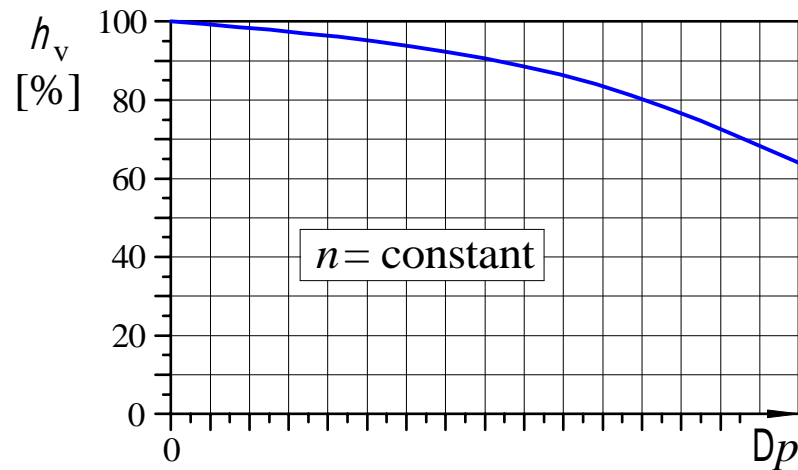

Wilson's pump model

$$q_{v2} = \varepsilon V_i n - C_s \frac{V_i \Delta p}{2\pi \nu \rho}$$

Theoretical output flow – Effective output flow

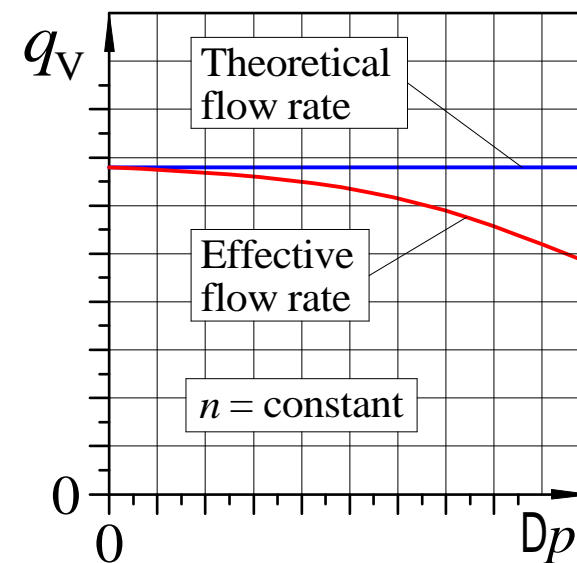
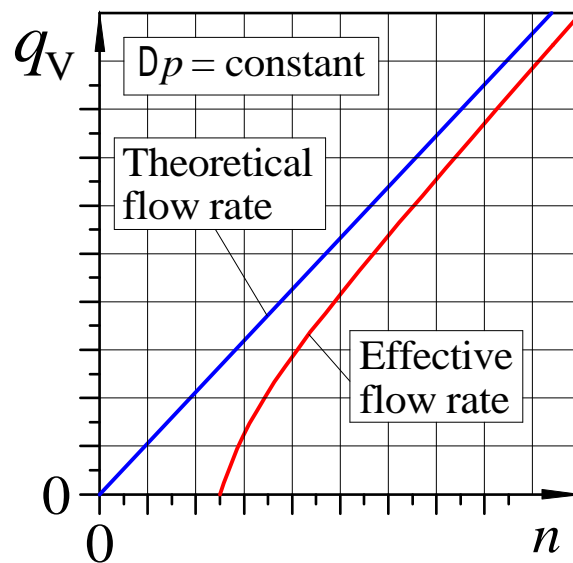

- ε pump angle set value (0 - 1)
- V_i max. displacement (per revolution)
- n rotational speed (1/s)
- C_s laminar flow loss coefficient
- Dp pressure difference over pump
- ν fluid kinematic viscosity
- ρ fluid density

Leakage flows in pumps

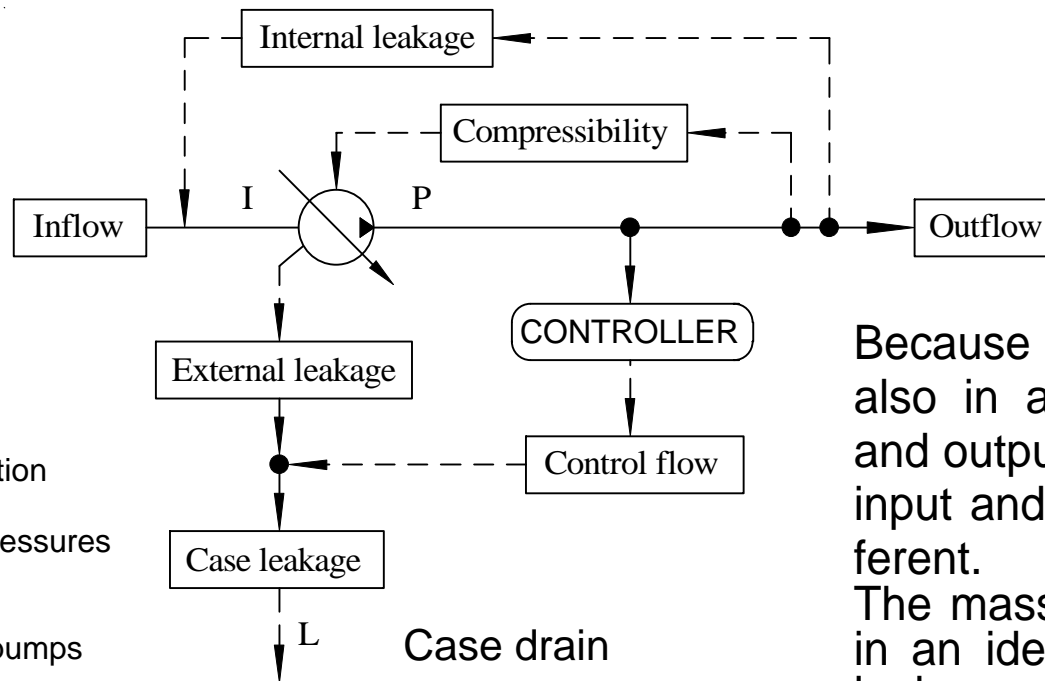

Internal leakage

- All pumps

External leakage

- With case drain connection
- To protect shaft seal
- To prevent high case pressures

Controller drain

- If pump has a controller
- Variable displacement pumps

Because of the fluid compressibility also in an **ideal pump** the input and output flow rates are different if input and output pressures are different.

The mass flow rates are the same in an ideal pump without external leakage.



Theoretic drive torque $T_{\text{theor}} = \frac{Dp \cdot V_g}{2 \cdot p}$

Swept volume V_g [m³/r]

Pressure difference Dp [N/m²]

Performance of pumps and motors

PUMP

Wilson's model

Flow rate (output)

$$q_{v2} = \varepsilon V_i n - C_s \frac{V_i \Delta p}{2\pi \nu \rho}$$

Pump torque (input)

$$T = \varepsilon \frac{V_i \Delta p}{2\pi} + C_f \frac{V_i \Delta p}{2\pi} + C_v V_i n \nu \rho + T_c$$

ε	Pump angle set value (0 - 1)
V_i	displacement (per revolution)
n	rotational speed (1/s)
C_s	laminar flow loss coefficient
Δp	pressure difference over pump
ν	fluid kinematic viscosity
ρ	fluid density
C_f	Coulomb friction coefficient
C_v	viscous friction coefficient
T_c	constant torque loss

Ideal pump and motor

Wilson's model is very simplistic and it can't explain all the phenomena in pumps (and motors).

Reference:

Ellmann, A., Kauranne, H. Kajaste, J. & Pietola, M.

EFFECT OF PARAMETER UNCERTAINTY ON RELIABILITY OF HYDRAULIC TRANSMISSION SYSTEM SIMULATION

Proceedings of IMECE2005 2005 ASME International Mechanical Engineering Congress and Exposition November 5-11, 2005, Orlando, Florida USA

Effective drive torque

$$T_{\text{real}} = \frac{Dp \times V_g}{2 \times \pi \times h_{\text{hm}}}$$

Wilson's pump model does not explain the phenomena seen in the figures below well

Friction – hydromechanical efficiency h_{hm}

$$T = \varepsilon \frac{V_i \Delta p}{2\pi} + C_f \frac{V_i \Delta p}{2\pi} + C_v V_i n v \rho + T_c$$

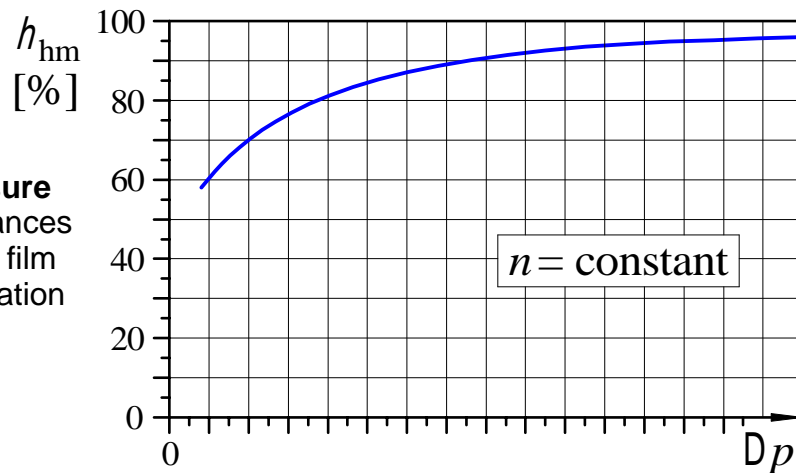

- Higher pressure**
- Wider clearances
 - Thicker fluid film
 - Better lubrication

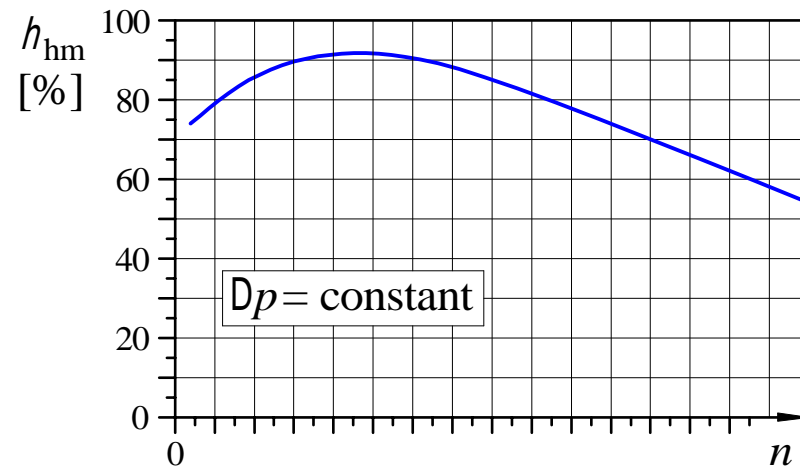

- Effect of n**
- At first Coulomb friction dominates
 - Then better lubrication
 - Finally hydraulic losses increase

Theoretical drive torque – Effective drive torque

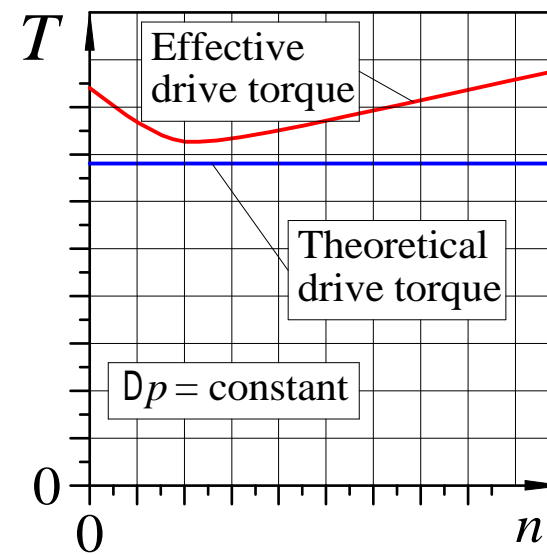
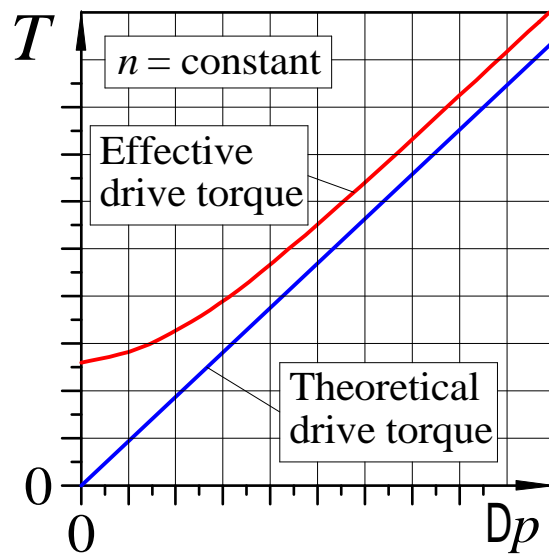

Theoretic drive power

$$P_{\text{theor}} = q_V \Delta p$$

Effective drive power

$$P_{\text{real}} = \frac{q_V \Delta p}{h_t}$$

$$h_t = h_v \Delta h_{\text{hm}}$$

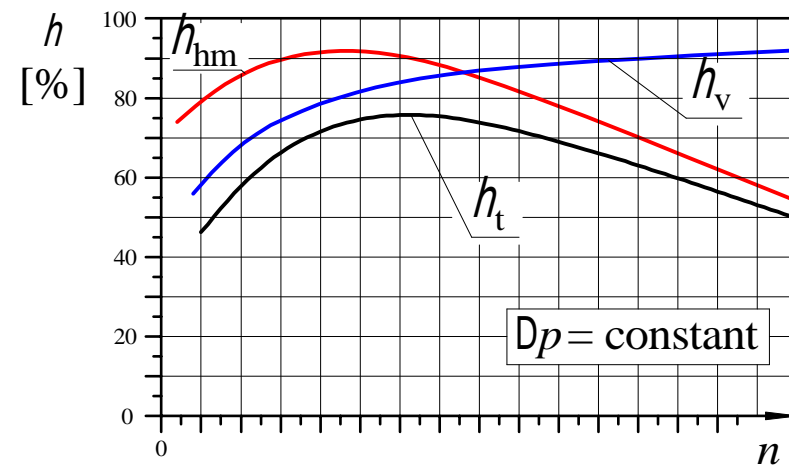
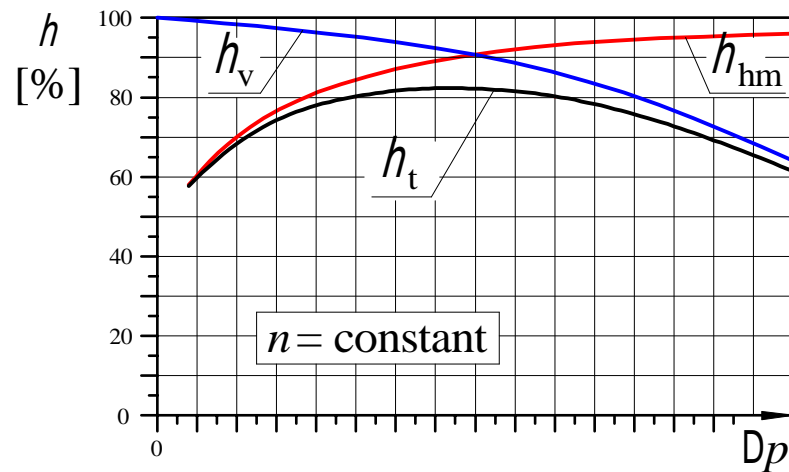

Theoretical drive power – Effective drive power

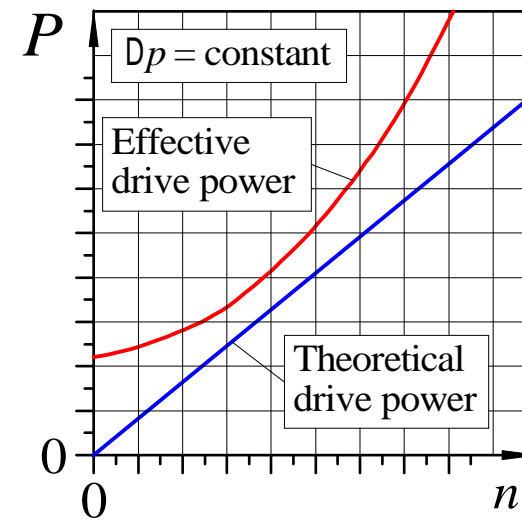
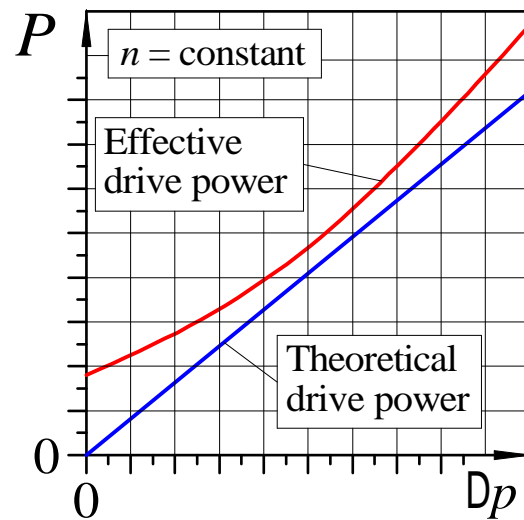

Comparison of structure types

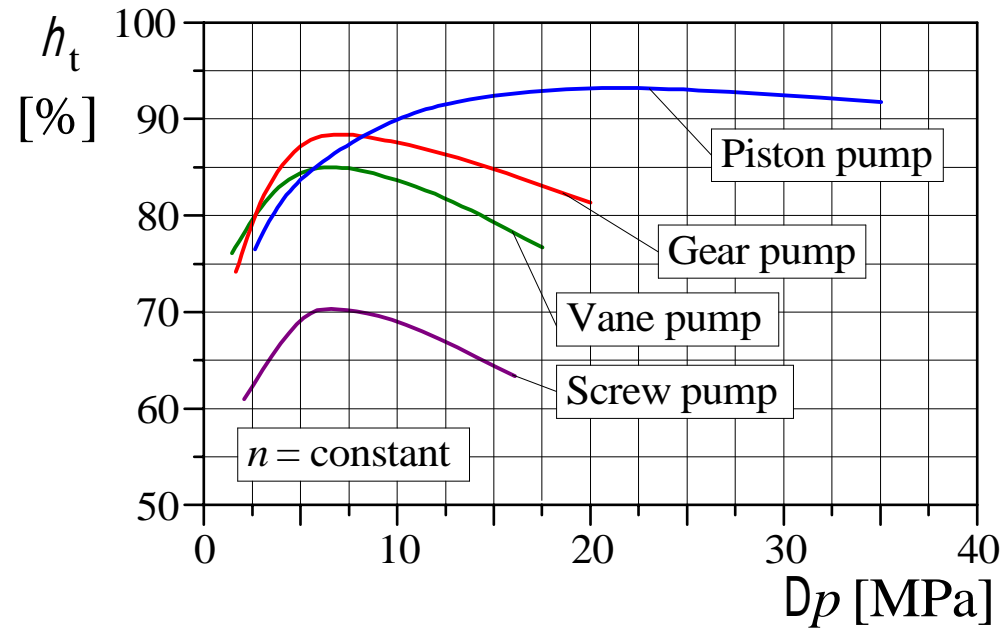

Characteristic curves of pump

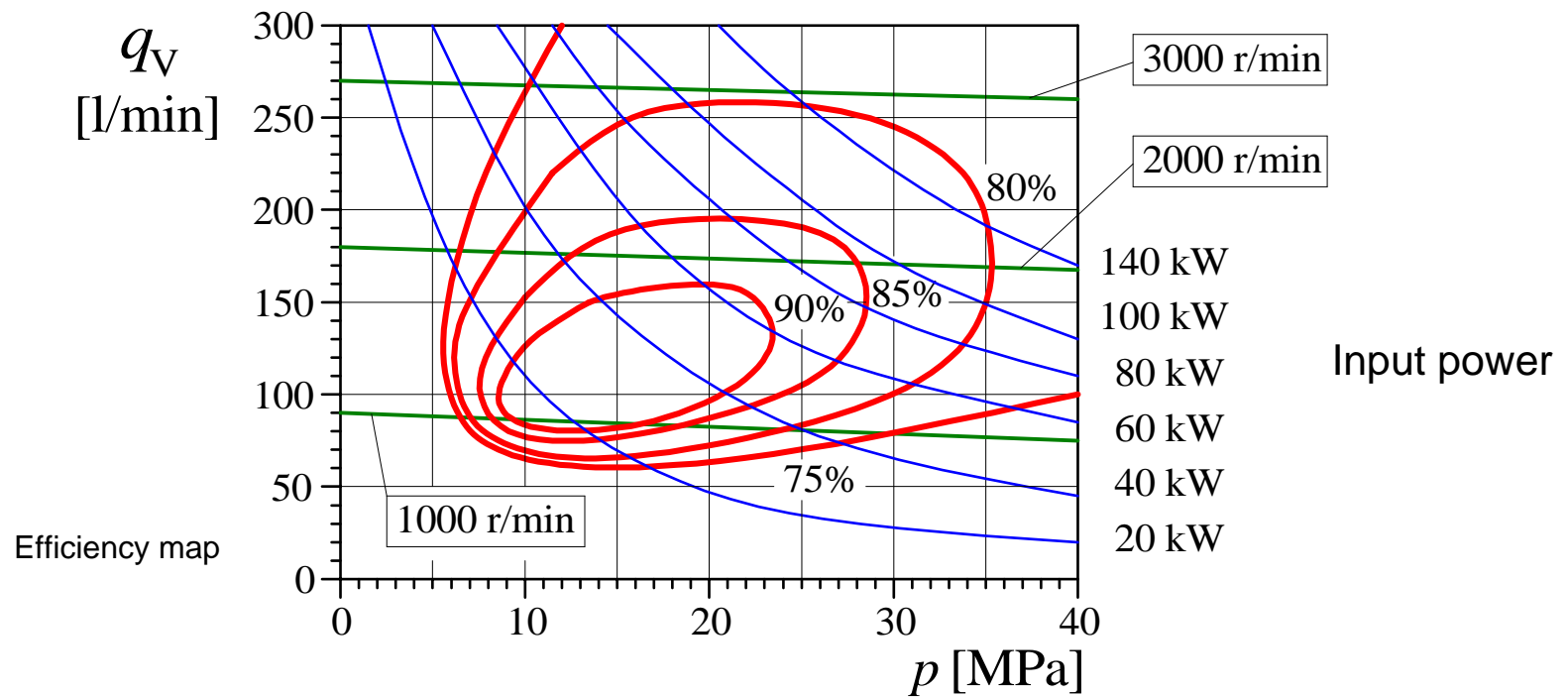

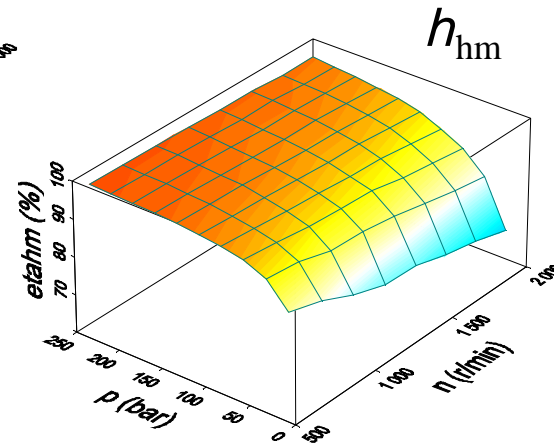
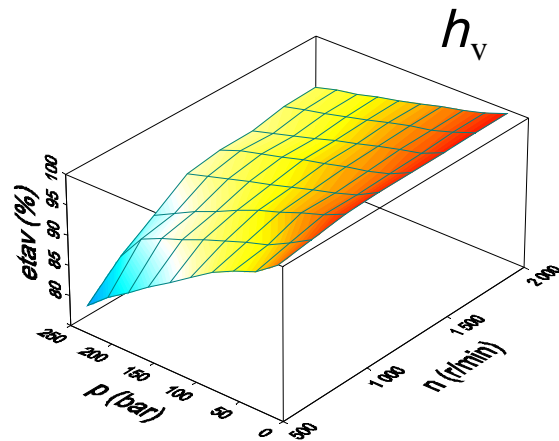

Example:
Pressure-rotational speed-
dependency of axial piston
pump

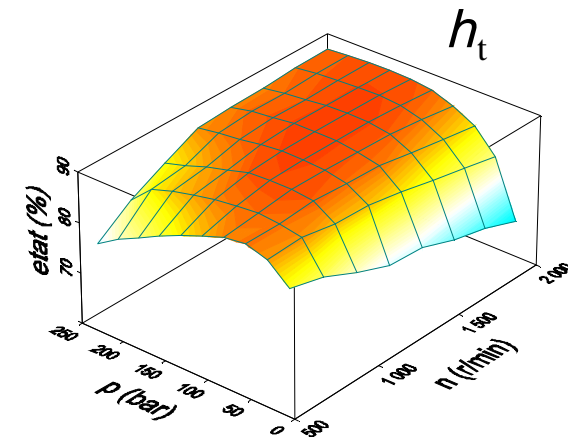

$$T = \varepsilon \frac{V_i \Delta p}{2\pi} + C_f \frac{V_i \Delta p}{2\pi} + C_v V_i n v \rho + T_c \quad \leftarrow \text{Wilson's model (check the effect of decreasing } \varepsilon)$$

ε Pump angle set value (0 - 1) (axial piston pumps)

$$q_{v2} = \varepsilon V_i n - C_s \frac{V_i \Delta p}{2\pi v \rho}$$

Effect of displacement setting value to the efficiencies in variable displacement pumps

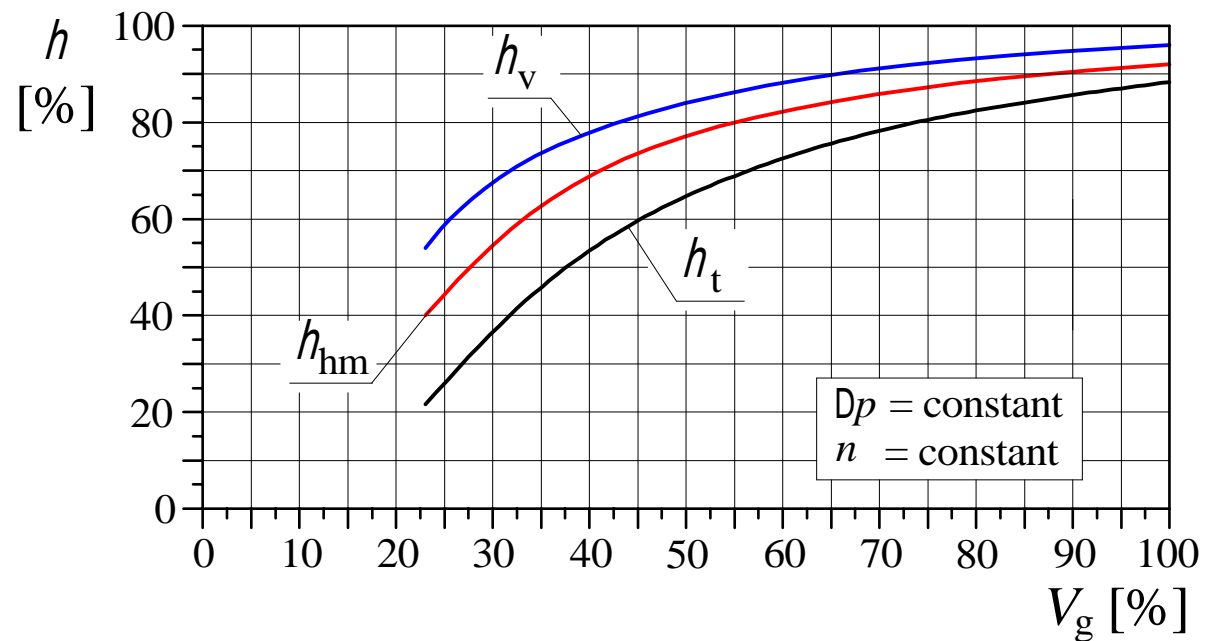

Factors affecting efficiency

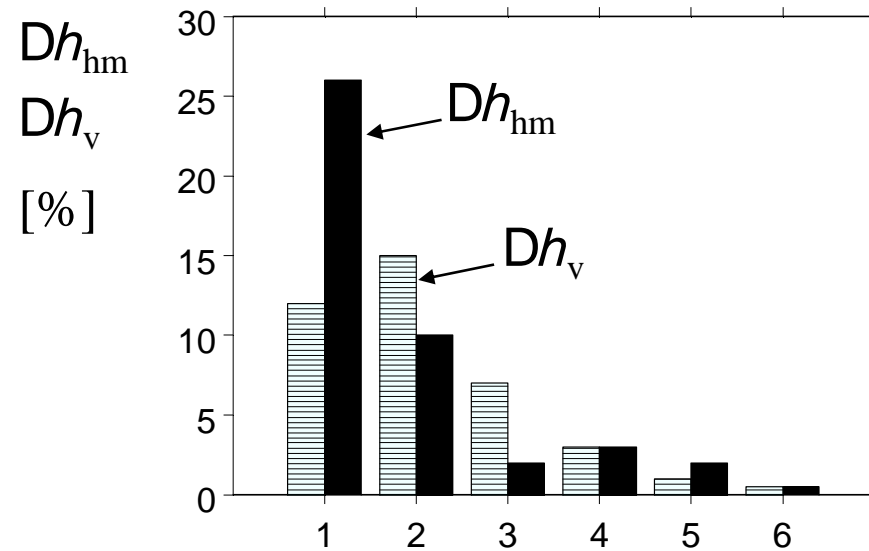

1: pressure 2: swept volume 3: rotational speed
4: temperature 5: pump specimen 6: fluid

Pump types

Gear pumps

- external gear
- internal gear

Screw pumps

Vane pumps

- vanes in rotor
- vanes in stator

Piston pumps

- line piston pumps
- radial piston pumps
- axial piston pumps

Gear pumps

Reduction of leakage by
 - axial gap compensation
 - radial gap compensation
 in some models

- Hydrodynamic bearings (typically)
- Roller bearings

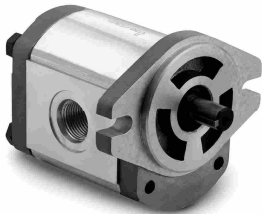
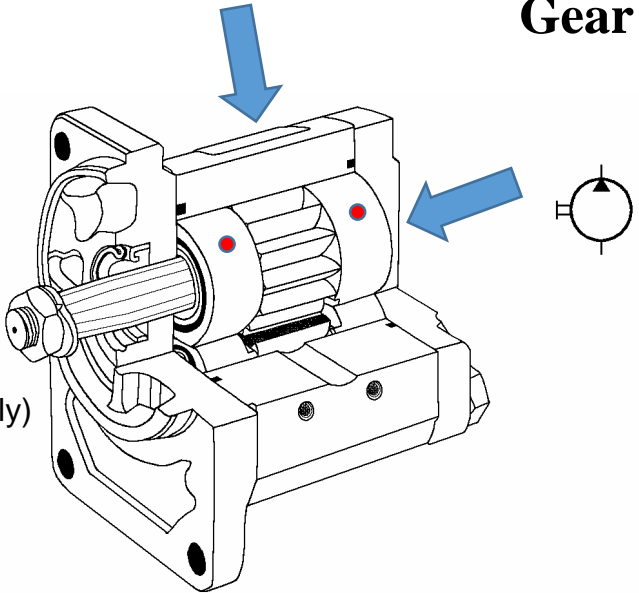

External gear
 - two gear
 - multi gear

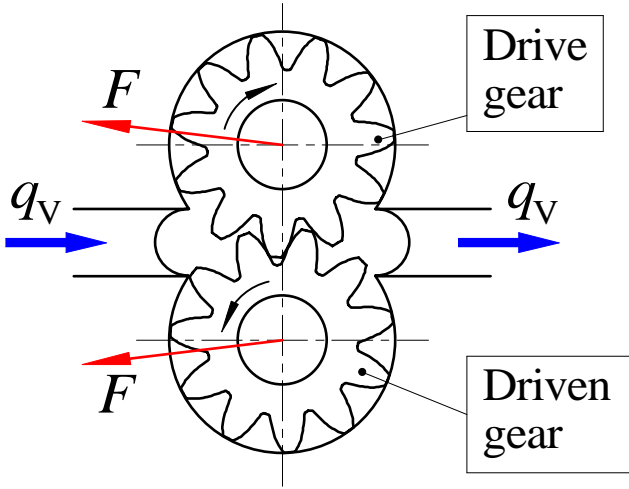

Internal rotor
External rotor

Axial compensation
Radial compensation
possible

- Low noise
- Even flow

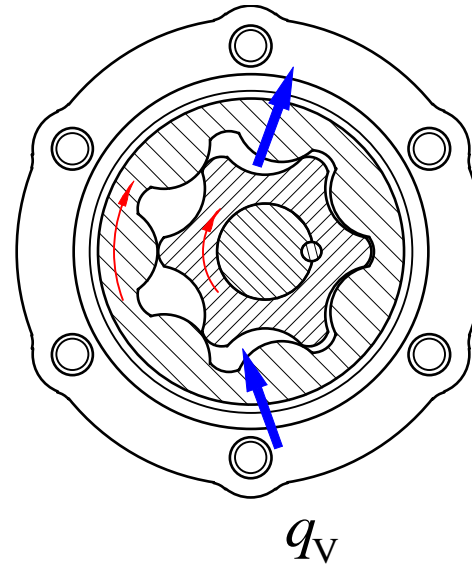
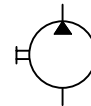
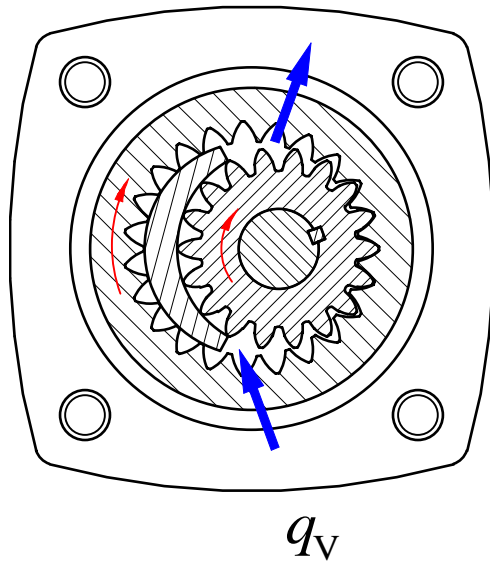

Internal rotor
External rotor

Also "roller rotor" design

Internal gear

- crescent (segment pump)
- gerotor (ring pump)

Performance characteristics of gear pumps

Total efficiency max. $\eta_t \gg 0.8 - 0.93$

Rotational speed range $n \gg 500 - 5000$ r/min

Operating pressure max. $p \gg 14 - 21 (- 32)$ MPa

- depends on compensation of leakage
and radial forces

Screw crests roll against screw roots and seal fluid chambers

Screw pumps

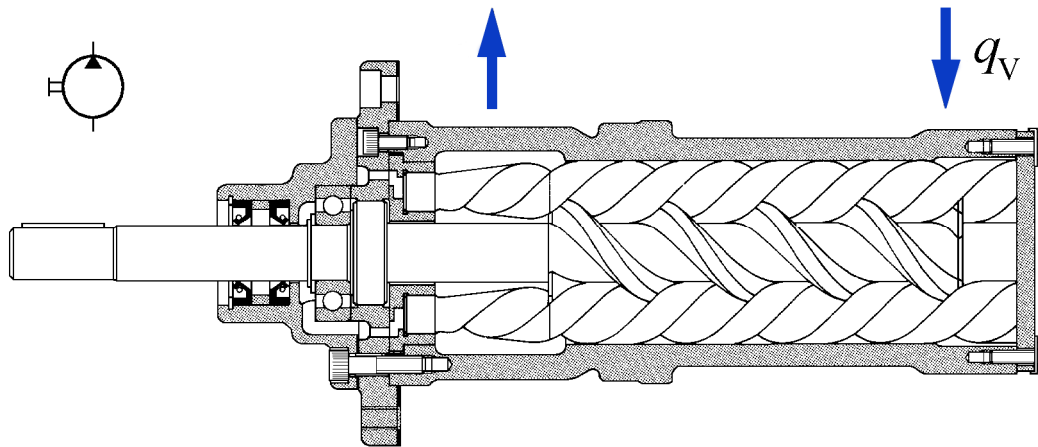

Fluid volumes do not change during movement
- Even flow
- Low noise
- High rotational speeds possible

Number of screws

- one
- two
- three

Total efficiency max. $\eta_t \gg 0.7 - 0.8$

Rotational speed max. $n \gg 30000$ r/min

Operating pressure max. $p \gg 14 - 20$ MPa

By altering eccentricity of rotor the displacement and even the flow direction can be changed.

Vane pumps

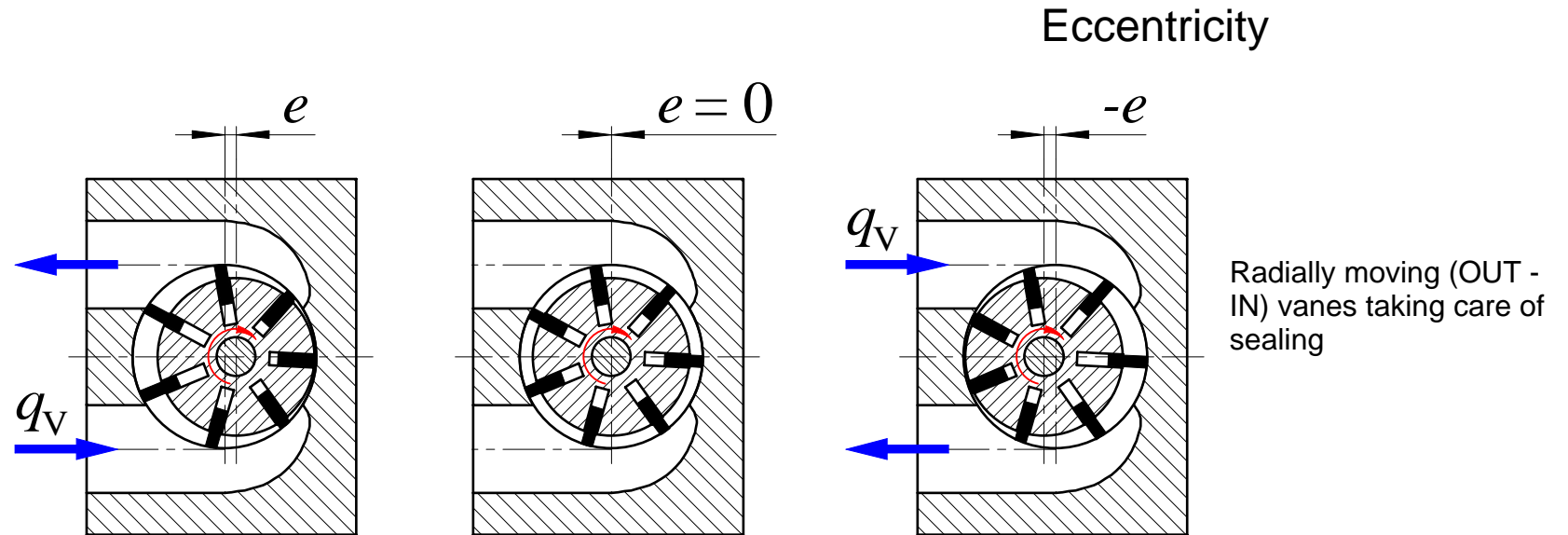

Vanes are pushed outwards to make a contact with the pump body
- with extra force behind vane (spring or pressure)
- "centrifugal force" (not a real force)

Variable displacement operation

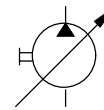
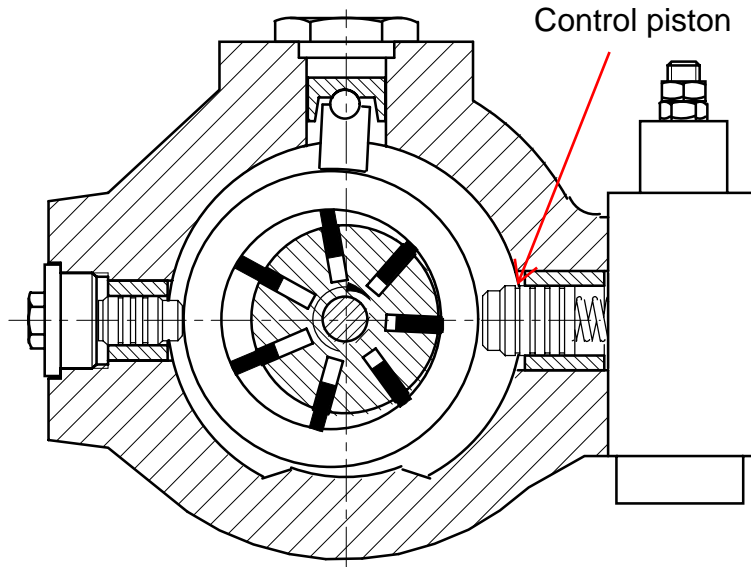

Vanes in rotor
- one chamber

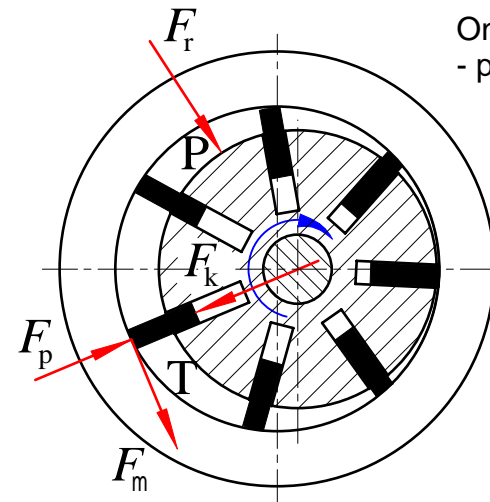

One chamber structure
- pressure forces acting on the shaft

Even flow
- low noise

Two chamber structure doubles the flow rate
(compared with one chamber models)

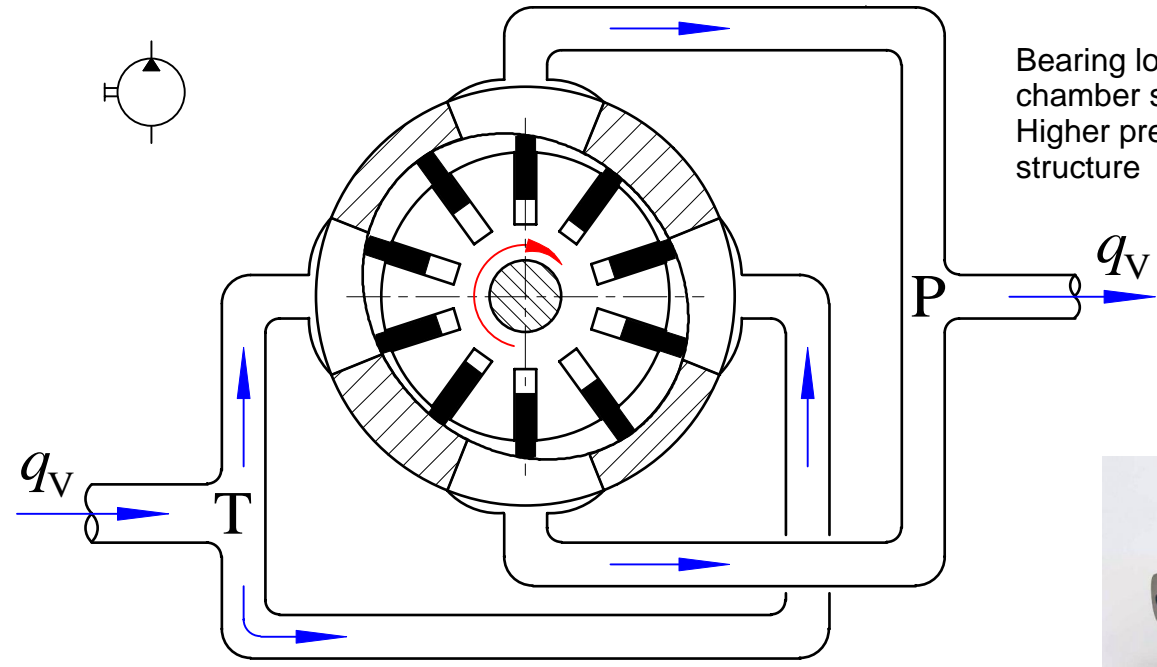

Bearing load forces are smaller than in one chamber structure
Higher pressures possible than in one chamber structure

Variable displacement operation possible with two pump rings in series



Vanes in rotor
- two chamber

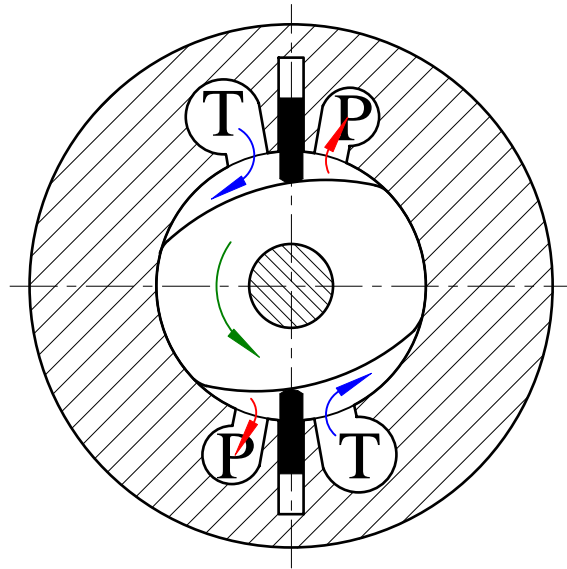

Flow rate varies slightly more than in other structures

Vanes in stator

Performance characteristics of vane pumps

Total efficiency max. $\eta_t \gg 0.8 - 0.92$

Rotational speed range $n \gg 600 - 2500$ r/min

Operating pressure max. $p \gg 7 - 14 (-18) (-21 - 28)$ MPa

- depends on compensation of leakage,
radial forces and number of chambers

Piston pumps

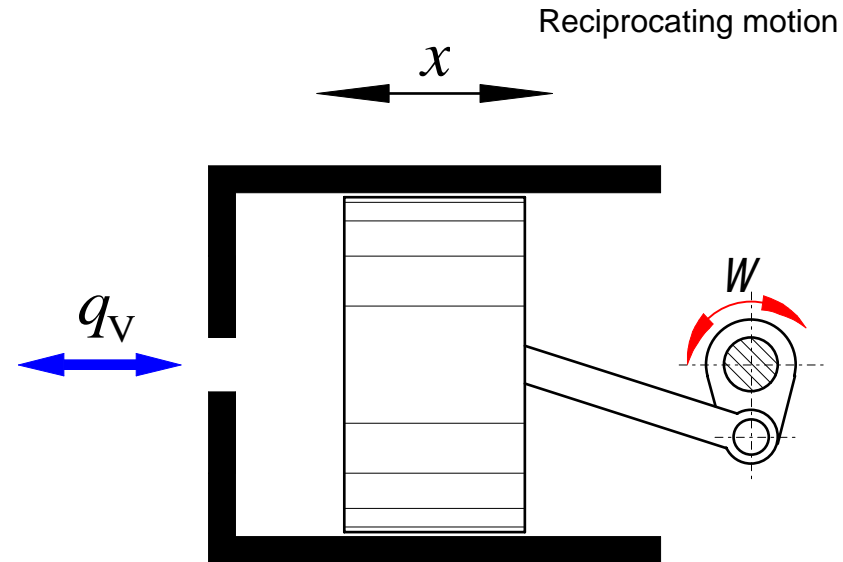

Piston pumps

- line piston pumps
- radial piston pumps
- axial piston pumps

Small clearances \Rightarrow Small leakages \Rightarrow Good volumetric efficiency

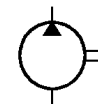
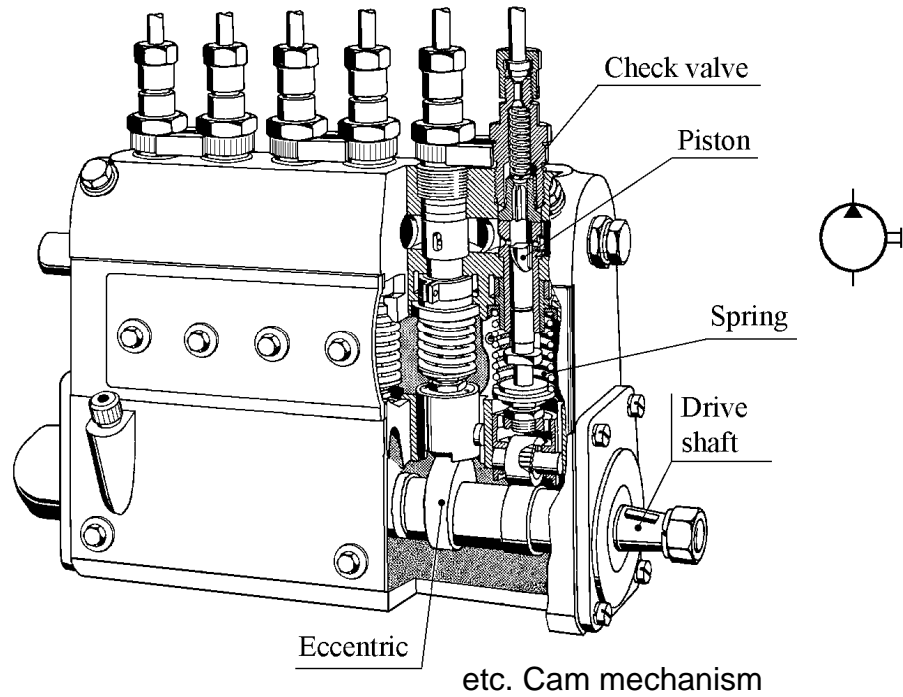

Mainly for high very pressures
 $\Rightarrow 1200 \text{ bar} \Rightarrow 2500 \text{ bar}$



Line piston pumps

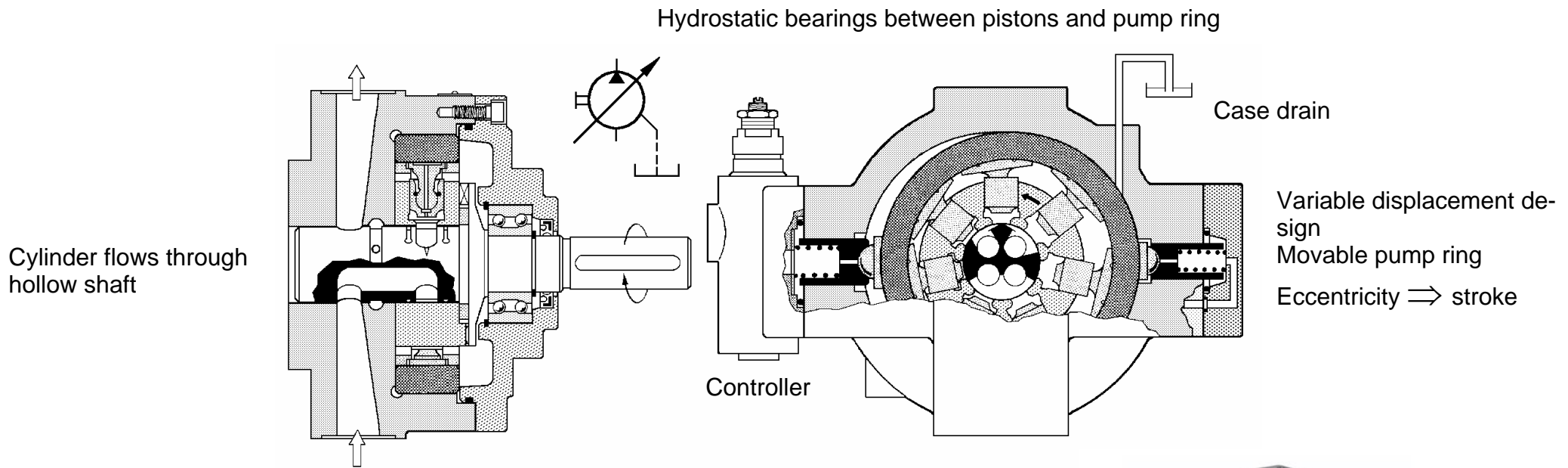

Radial piston pumps

- internal flow channels
- external flow channels

High pressures possible up to 450 bar



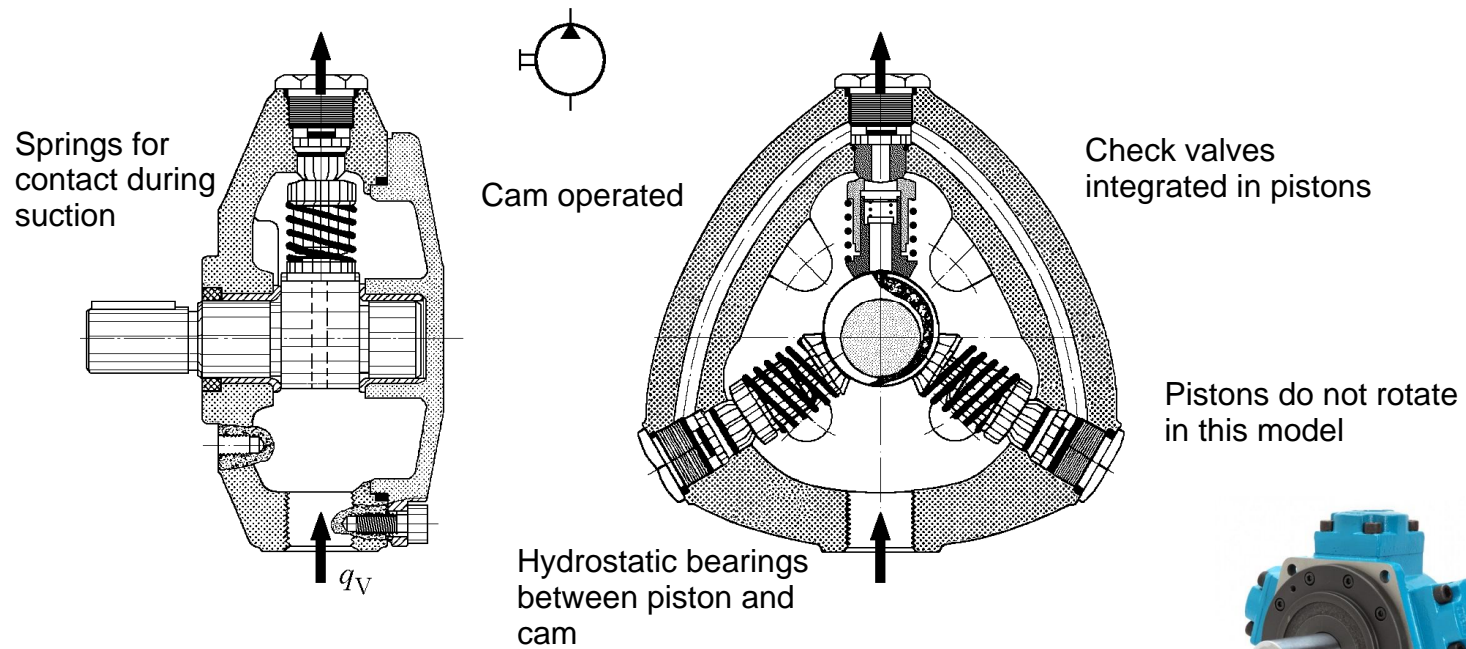

High pressures up to 600 - 700 bar possible



Radial piston pumps
 - internal flow channels
 - external flow channels

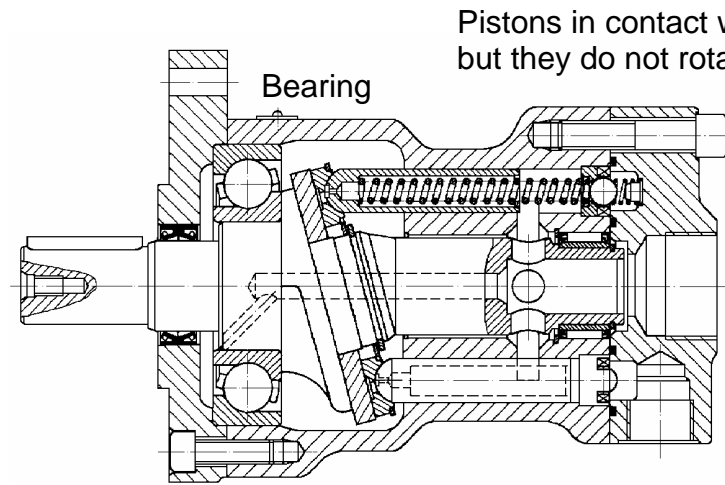

Pistons in contact with the plate,
but they do not rotate

Bearing

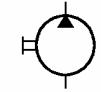

Possibility to transform this type to
"digital" by disconnecting some of
the pistons

The rotating masses are not in
balance which limits the rotational
speed

Without special arrangements the contact
forces between piston and wobble plate
cause radial forces to piston

Pistons in parallel with the shaft

Wobble plate rotates with shaft

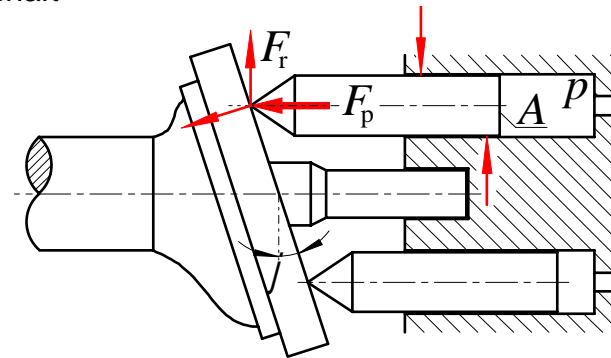

Axial piston pumps

- wobble plate pumps
- swash plate pumps
- bent axis pumps

The direction of flow can be changed in some models

(-18° [®]) 0° [®] +18°

Contact forces between pistons and swash plate limit the control angle

Rotational speeds can be 1500 - 3000 rpm

Cylinder block rotates with the shaft
Swash plate does not rotate, it can turn to control the piston stroke and pump displacement

Counter piston for swash plate control

Hydrostatic bearing between pistons and swash plate

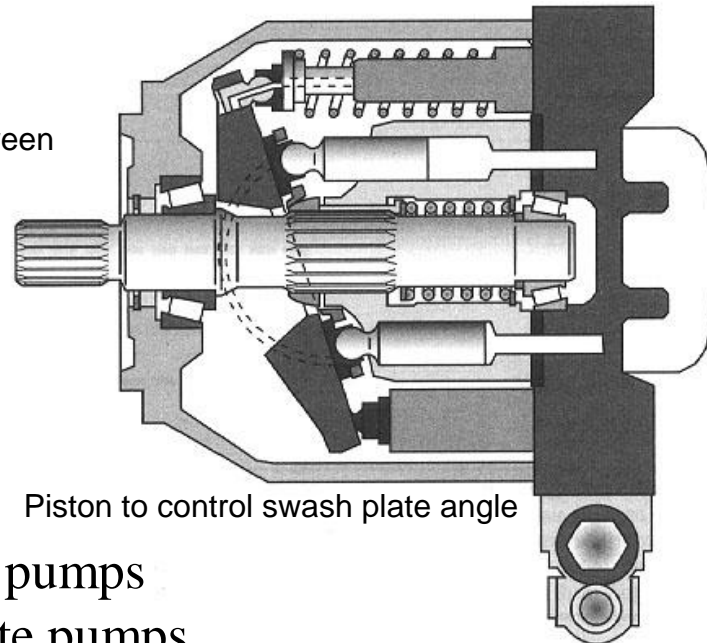

Piston to control swash plate angle

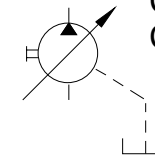

Case drain because of hydrostatic bearings
Case pressure must be kept small!

Axial piston pumps

- wobble plate pumps
- **swash plate pumps**
- bent axis pumps

swashplate pump - inline piston pump

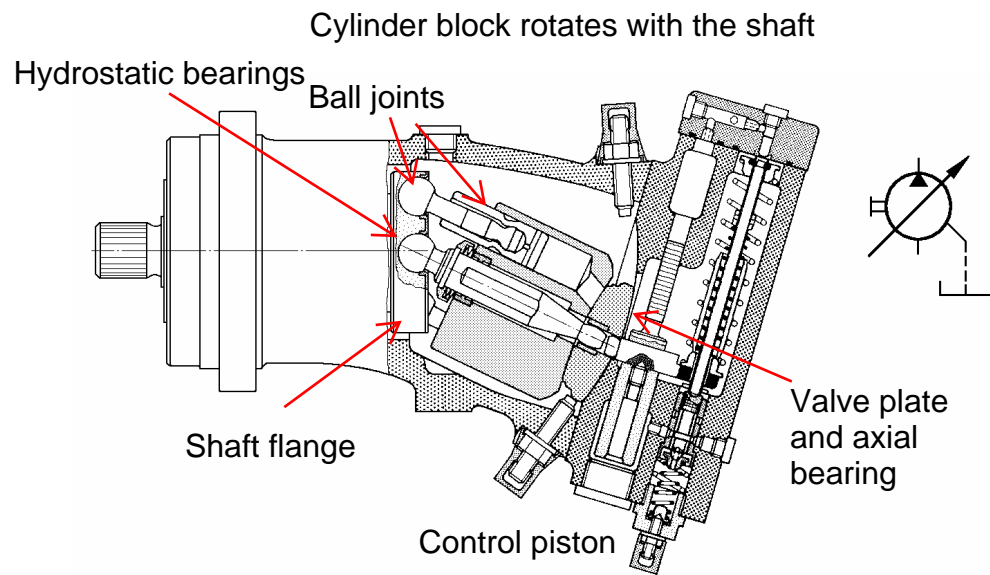

Size is typically large especially with controllers

- Rotation transmitted with
- Cardan shaft
 - Bevel gear
 - Pistons

Radial forces on piston are small

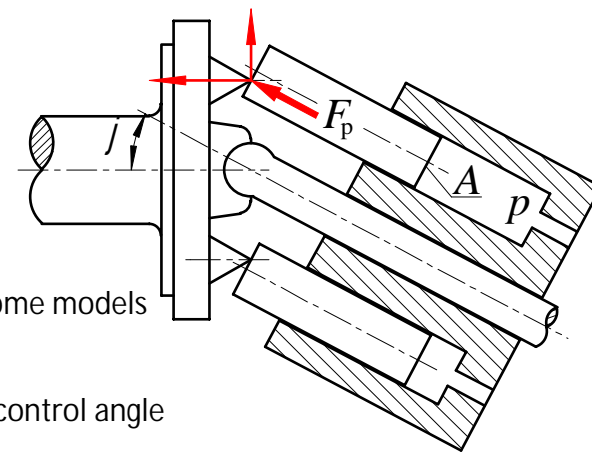

Axial piston pumps

- wobble plate pumps
- swash plate pumps
- bent axis pumps

The direction of flow can be changed in some models
 (-25° $\text{\textcircled{R}}$) 0° $\text{\textcircled{R}}$ +25°

Contact forces of pistons do not limit the control angle as much in this model
 Rotational speeds can be 800 - 8000 rpm

Performance characteristics of piston pumps

Total efficiency max. $\eta_t \gg 0.8 - 0.9$ even higher

Rotational speed range $n \gg 300 - 8000$ r/min

Operating pressure max. $p \gg 20 - 35$ (– 45) (– 70) (– 250) MPa
- depends on structure type

Hydraulic motors

Convert hydraulic power into mechanical power

Unidirectional

Bidirectional

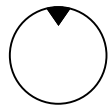

Constant displacement

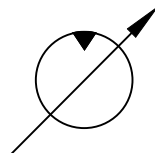
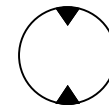

Variable displacement

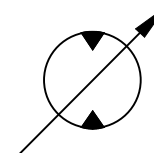

Speed ranges and structures

Speed range	r/min
Slow	1- 150
Middle	10- 750
High	300- 5000



Most common construction types:

- gear
- vane
- piston

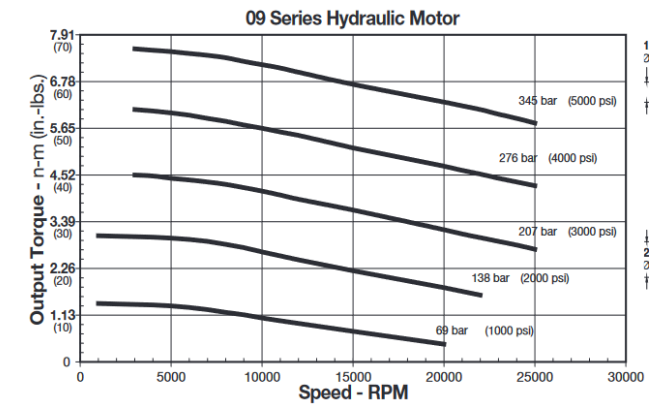

Parker Oildyne 09 gear motor

All operate on positive displacement principle

<http://www.parker.com/literature/Oildyne/Oildyne%20-%20PDF%20Files/07%20-%2009%20Series%20hydraulic%20gear%20motors.pdf>

Pump-motors

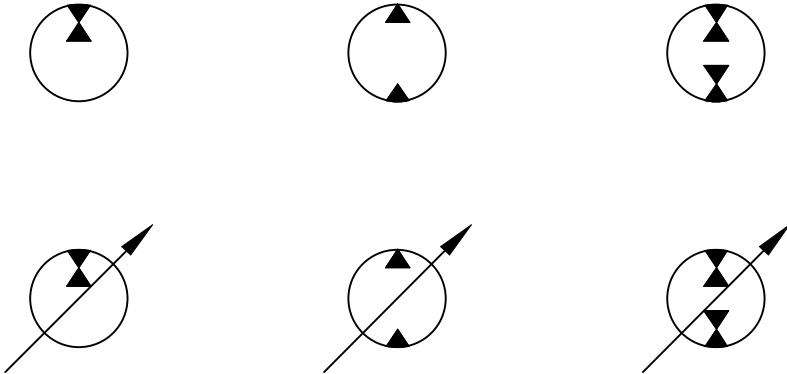

Control of flow direction

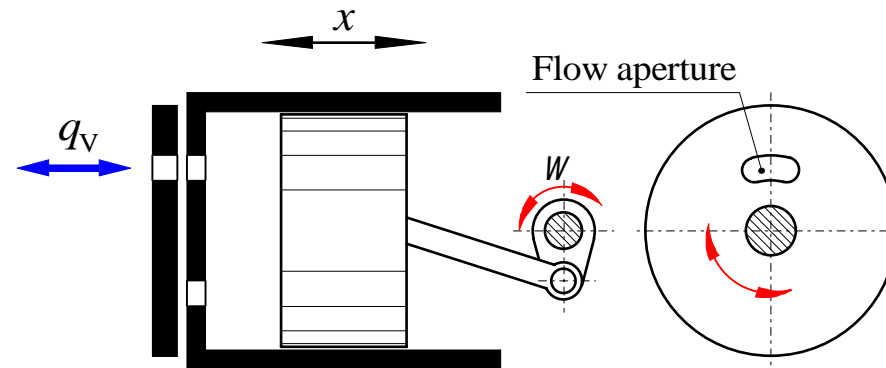

Only forced control is applicable

Operating phases:

Fluid flows into transfer volume – work phase

Fluid flows out from volume – free phase

Forced control

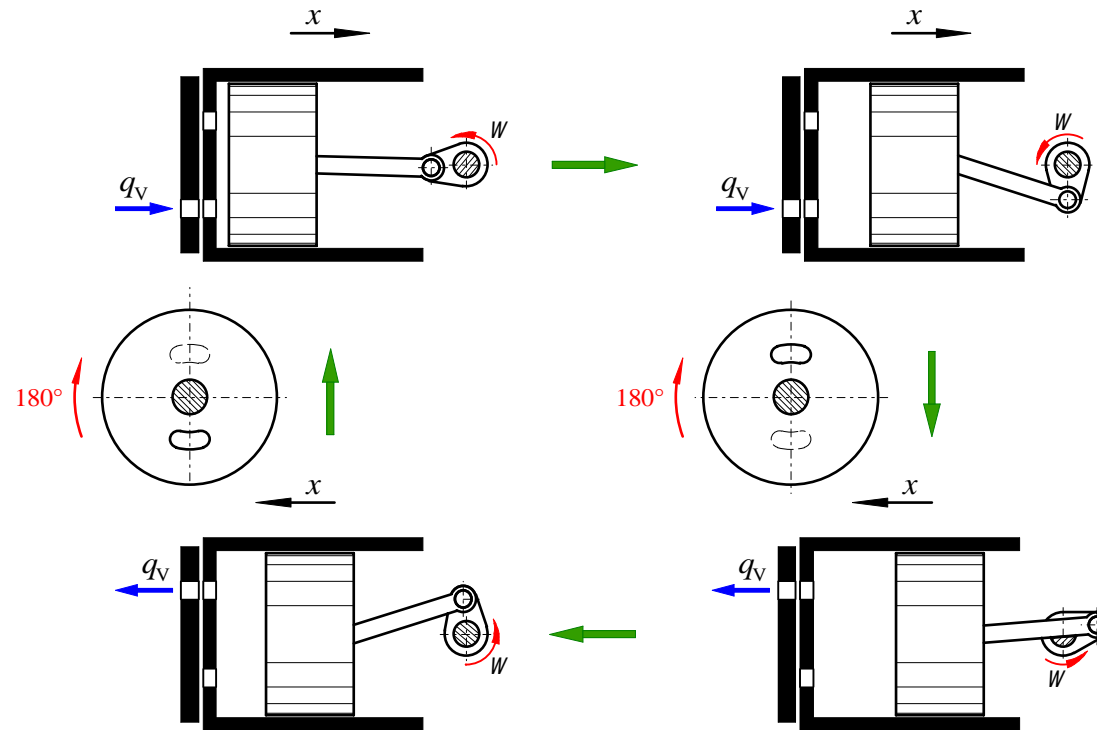

Motor characteristics

Starting characteristics

Especially at low rotational speeds
the operation can be uneven
a) rotational speed
b) torque
- displacement
- leakage
- friction (bearing type)
change

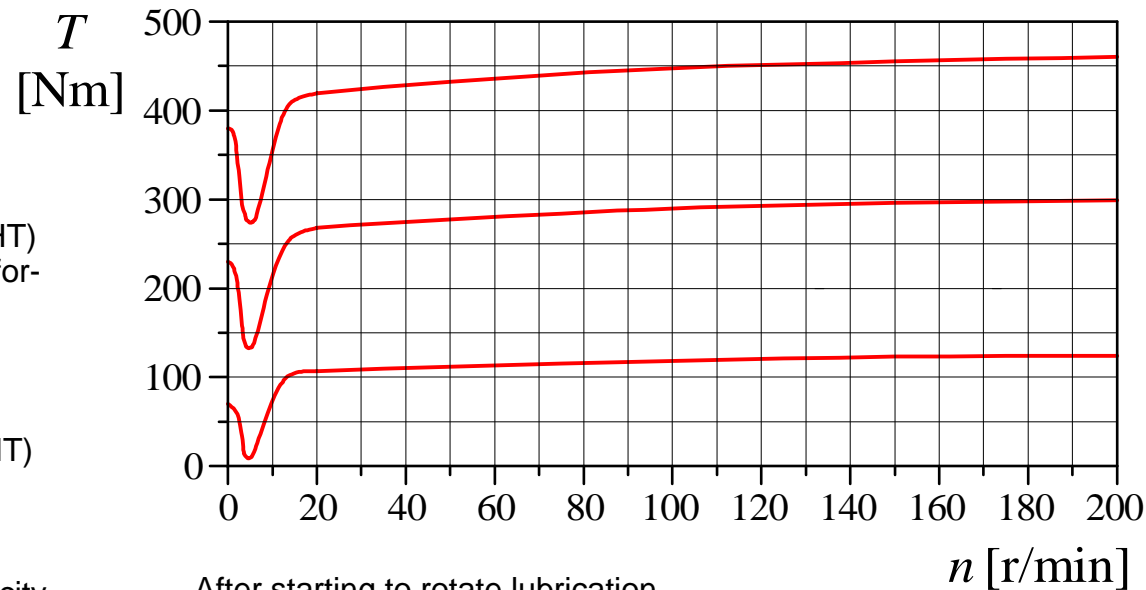

Low Speed High Torque (LSHT)
motors have good quality performance at low speeds!
Bearings
hydrostatic - hydrodynamic
Loading of motor?
Full load at slow speeds (LSHT)

Higher speeds:
- less (relative) leakage
- inertia effects -> steady velocity

After starting to rotate lubrication
problems with low speeds ->
torque diminishes

Running characteristics

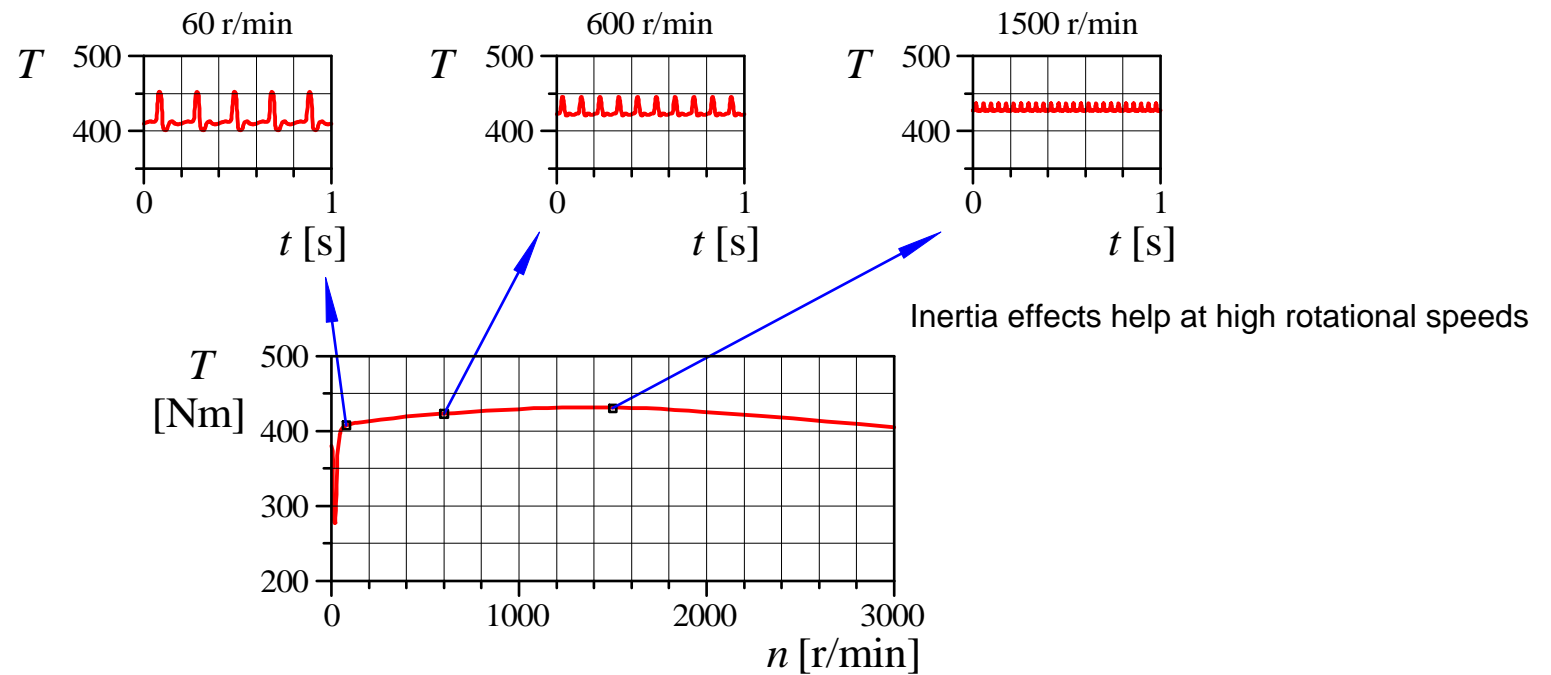

Theoretical flow demand $q_{V,\text{theor}} = n \triangleright V_g$

Swept volume V_g [m³/r]

$$\text{cm}^3/\text{r} = 10^{-6} \text{ m}^3/\text{r}$$

Rotation speed n [r/s]

$$\text{r/min} = 1/60 \text{ r/s}$$

$$q_{V,\text{theor}} = \omega \triangleright V_{\text{rad}}$$

$$\omega = 2\pi \triangleright n$$

Angular velocity ω [rad/s]

$$V_{\text{rad}} = \frac{V_g}{2\pi}$$

Swept volume per radian V_{rad} [m³/rad]

Effective flow demand

$$q_{V,\text{real}} = \frac{n > V_g}{h_v}$$

Leakage – volumetric efficiency h_v

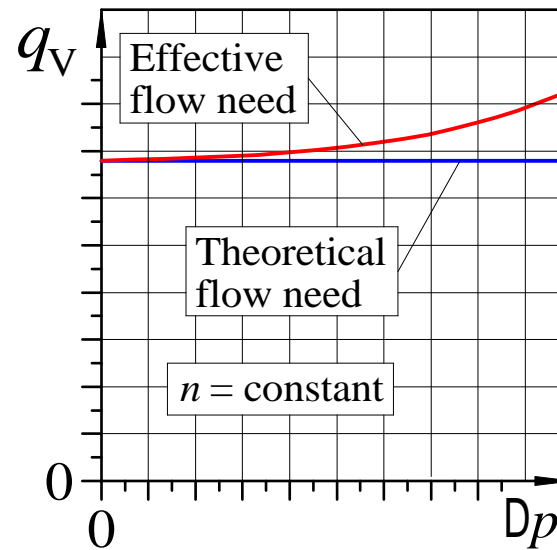
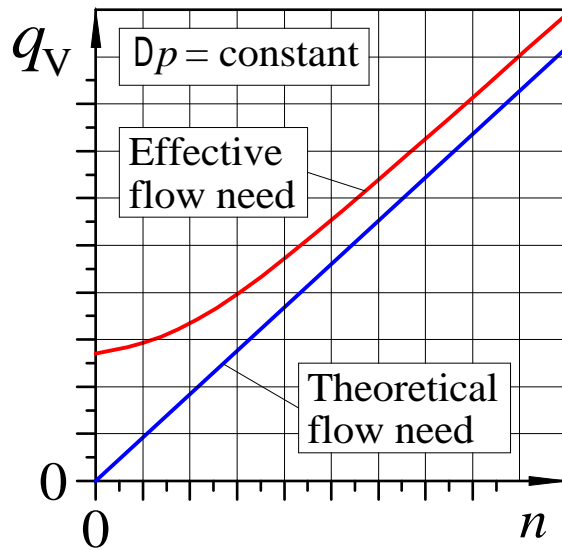

Leakage flows in motors

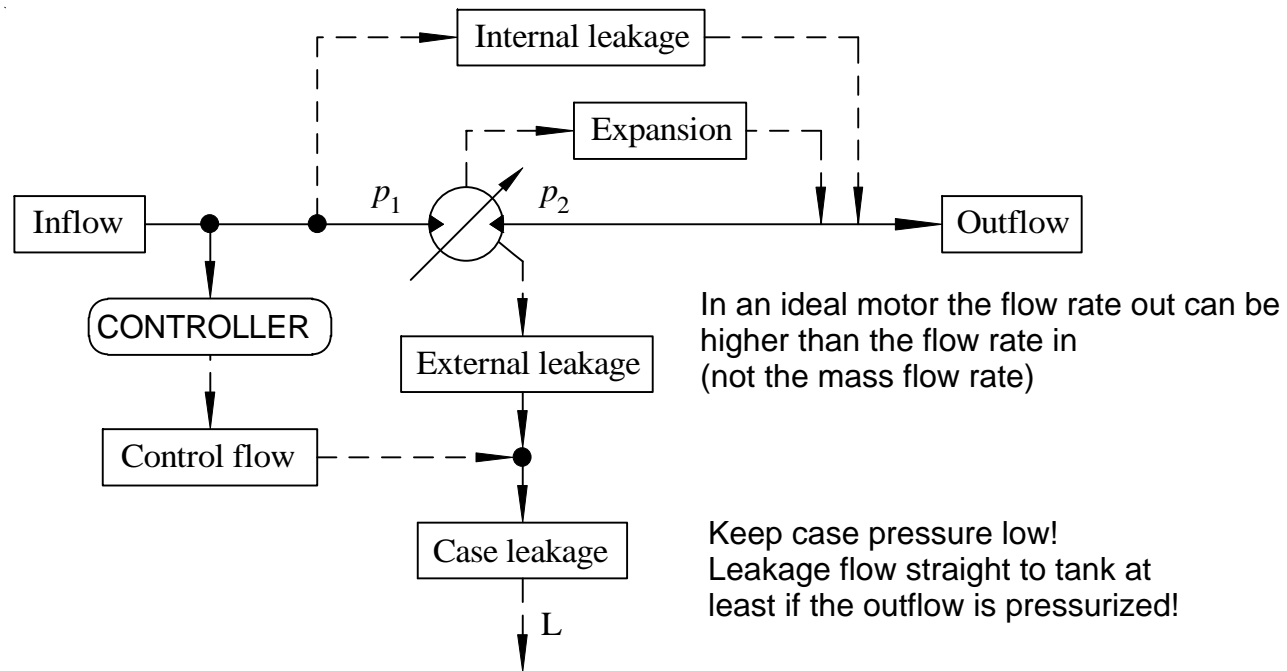

Theoretic pressure demand

$$Dp_{\text{theor}} = \frac{2 \rho g T}{V_g}$$

Effective pressure demand

$$Dp_{\text{real}} = \frac{2 \rho g T}{V_g \eta_{\text{hm}}}$$

Friction – hydro-mechanical efficiency η_{hm}

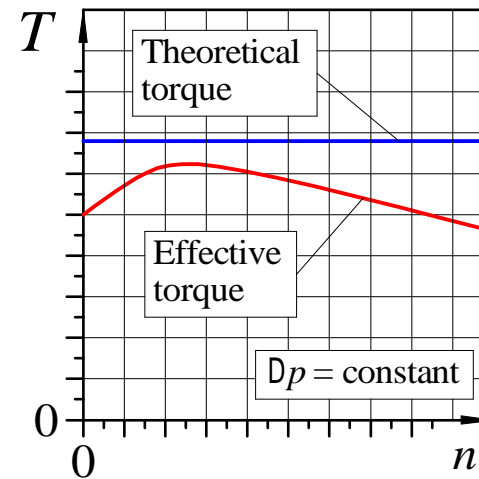
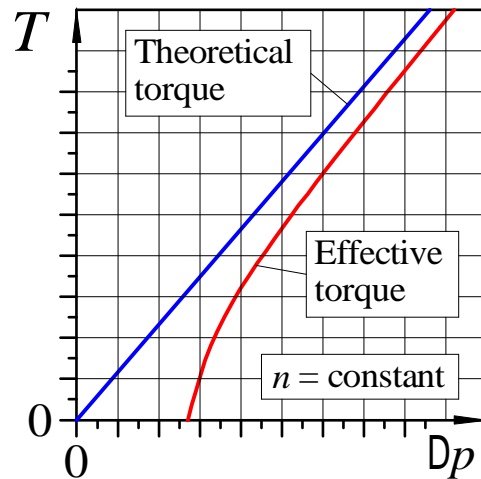

Theoretic power demand

$$P_{\text{theor}} = q_v \Delta p = T \omega$$

Effective power demand

$$P_{\text{real}} = q_v \Delta p = \frac{T \omega}{h_t} \quad h_t = h_v \eta_{\text{hm}}$$

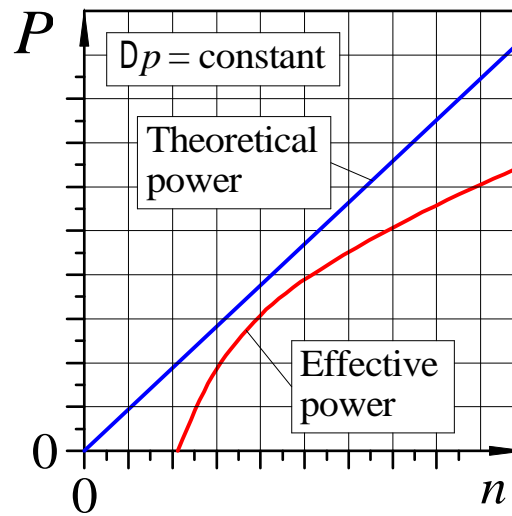
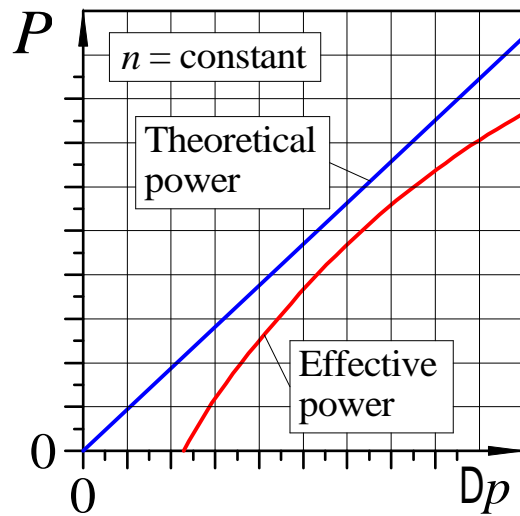

Power demand of load

$$P_{\text{mech}} = T \omega = 2 p \eta T$$

Characteristic curves of motor

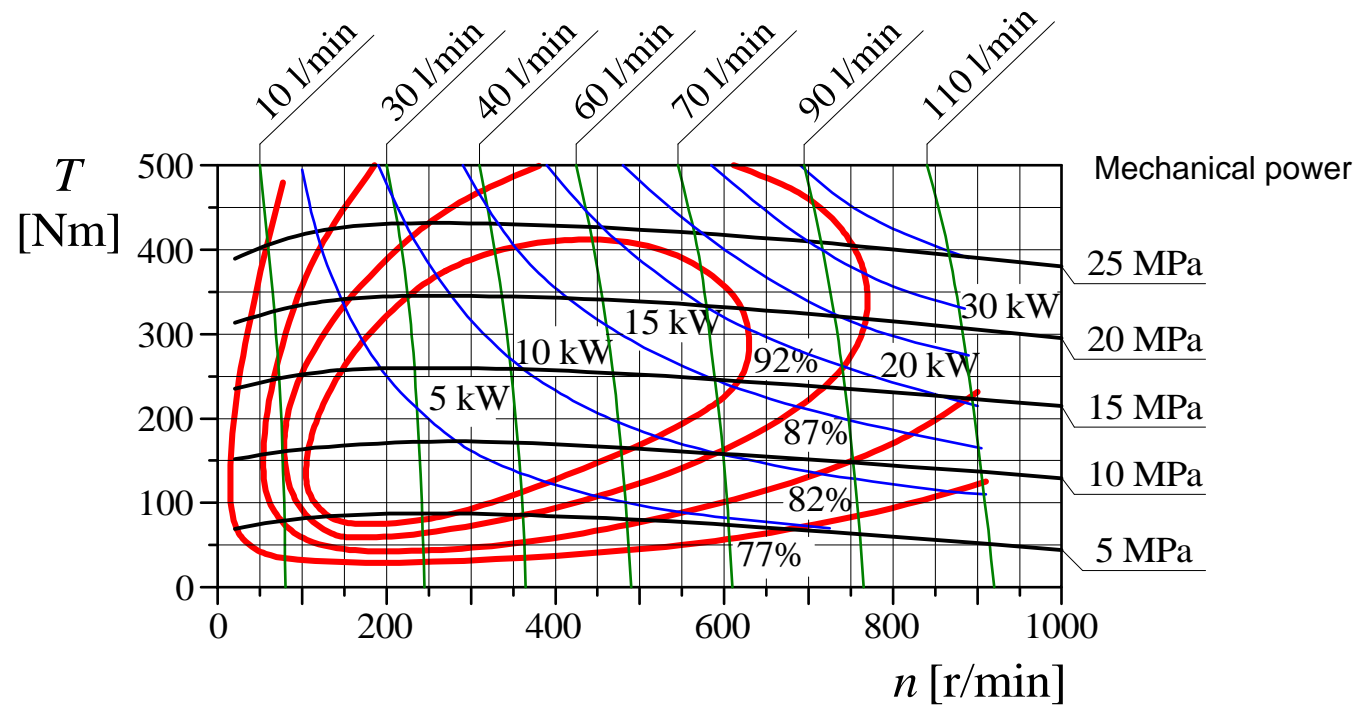

Low speed high torque motors (LSHT)

Large swept volume

- large displacement area of working elements
- several work stages per one rotation of the axle

Radial piston motors

Vane motors with several chambers

Orbital motors

Total efficiency max. $h_t \gg 0.8 - 0.92$

Rotational speed range $n \gg 1 - 500 (-2400)$ r/min

Torque max. $T \gg 1000 - 20000 (-125000)$ Nm

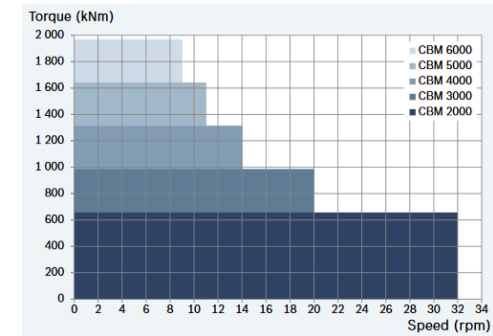

Maximum torque 1.97 MNm

Bosch - Rexroth Hågglunds

CBm radial piston motor

Radial piston motors

- external flow channels
- internal flow channels

Hydrostatic bearings

External flow channels

Eccentric

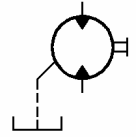
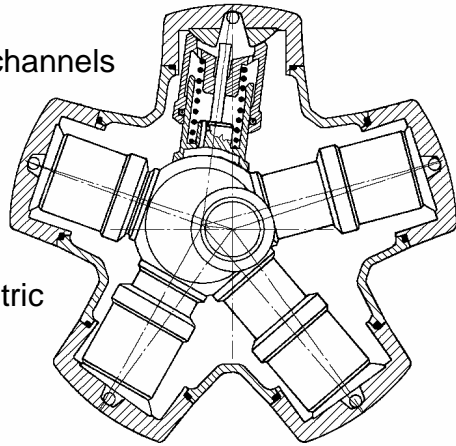

Case drain

Up to 420 bar



Internal flow channels

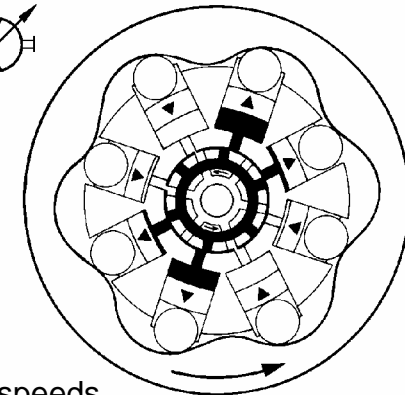
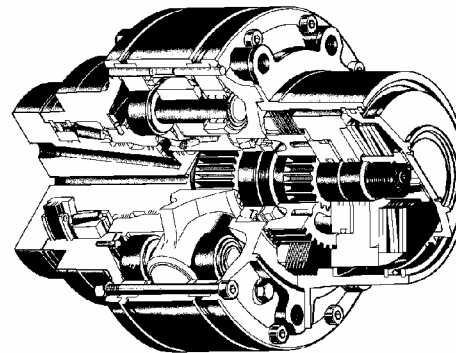

Cam mechanism, several cams for one revolution

Rotating housing

Opposite cylinder forces cancel internal bearing loadings

Can be freewheeled (springs) during on-road operation (trailer), 2 speeds

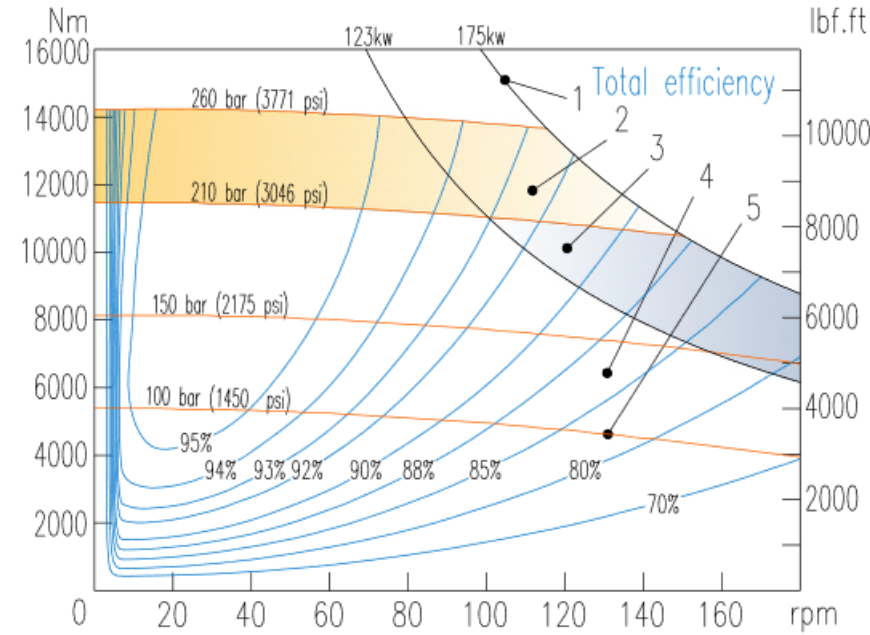

Stepwise change of displacement

Three displacements: 1, 2 and 1+2

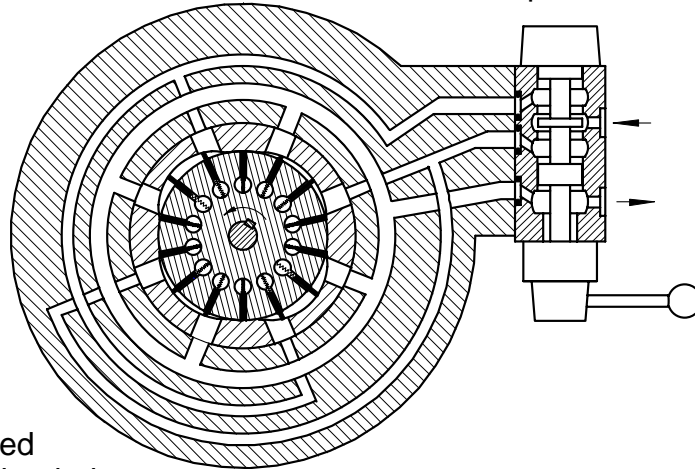

Multi chamber vane motor

<http://files.danfoss.com/documents/52010262.pdf>

4 chamber model
Radial forces cancelled
Spring and pressure loaded vanes

Drum distributor valve (or disc valve)

Orbital motor ®

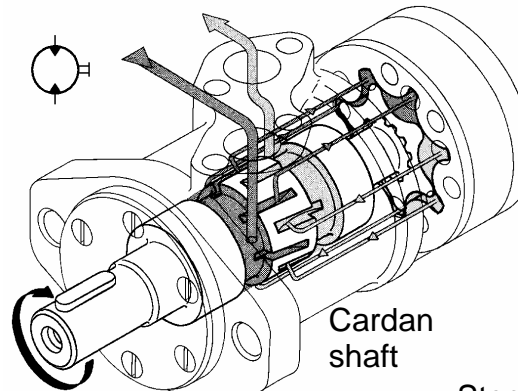

External gear
Stator, 7 cams

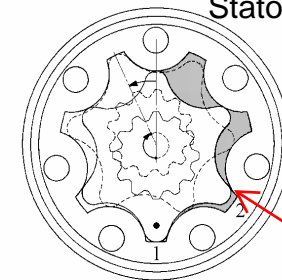

For one rotation 42 tooth volumes have to be filled

Rotor, 6 cams
Internal gear

Models with rollers also

Stepwise displacement changes possible

Middle speed range motors

Gerotor motors (ring motors)

Wobble plate motors

Total efficiency max. $h_t \gg 0.8 - 0.88$

Rotational speed range $n \gg 200 - 1000 (-1500)$ r/min

Torque max. $T \gg 20 - 200 (-1200)$ Nm

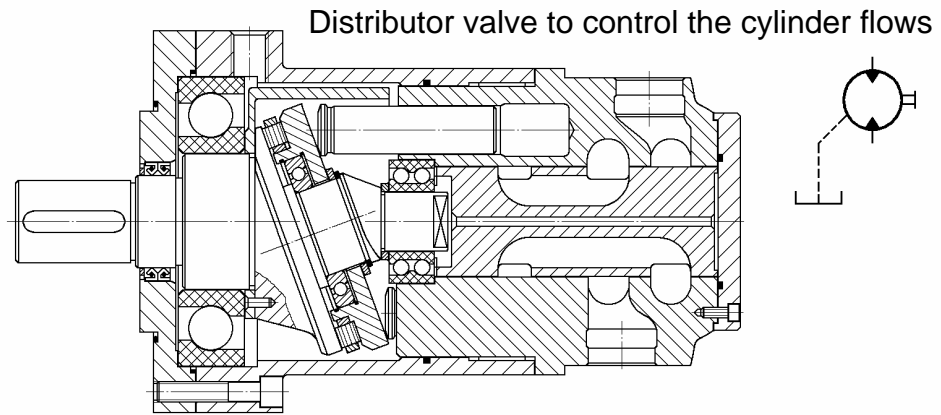

Constant displacement
Medium speed because of rotor's mass imbalance

Gerotor motor (ring motor) ®

Wobble plate motors

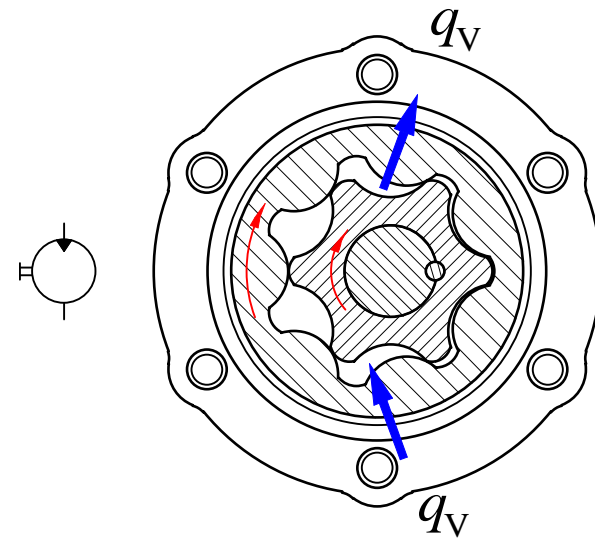

High speed range motors

External gear motors

Vane motors

Axial piston motors

Total efficiency max. $h_t \gg 0.82 - 0.9$

Rotational speed range $n \gg 100 - 3000 (- 6000)$ r/min

Torque max. $T \gg 10 - 700 (- 3000)$ Nm

Rotational speed may change frequently -> accelerations

Medium pressure (180 bar) unless radial compensation (250 bar)

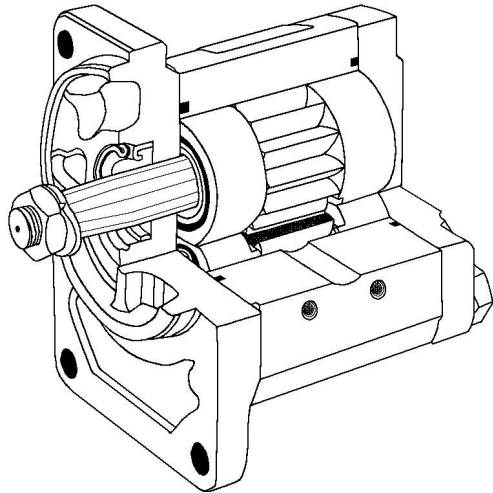

External leakage connection needed if outlet flow is pressurized

→ External gear motor



Some models with needle bearings for better performance at low speeds

Vane motor ®

Medium pressure (up to 210 bar)

Constant or variable displacement

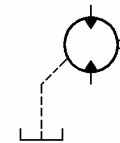
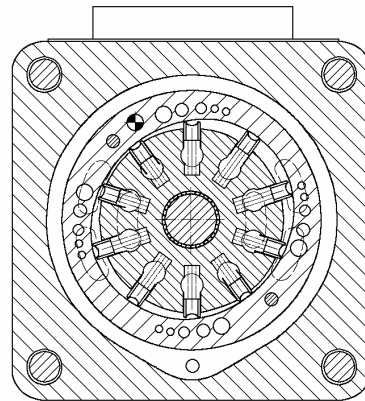

Hydraulic forces in balance

External leakage connection for pressurizing of both flow channels



Parker F12 bent axis motor

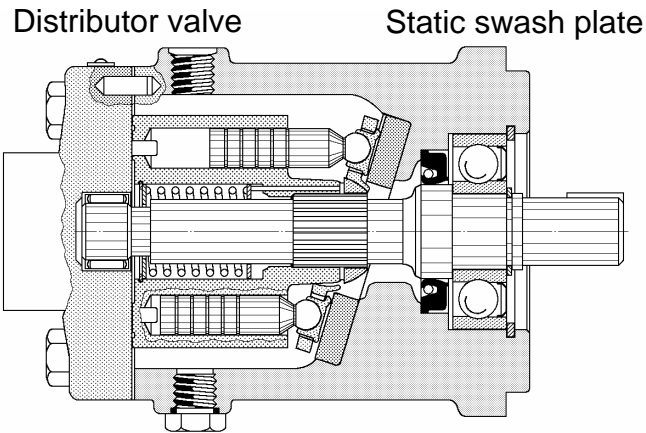
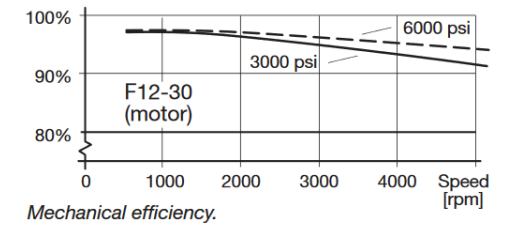
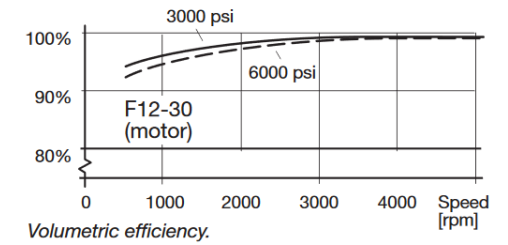

Up to 350 bar
High efficiency

Constant or variable displacement
In variable models typically 7°-18° control angle

Limited by radial forces (large) and and weakening of hydromechanical efficiency (small)

Bent axis ®
piston motor

Swash plate piston motor

Distributor valve Constant or variable displacement

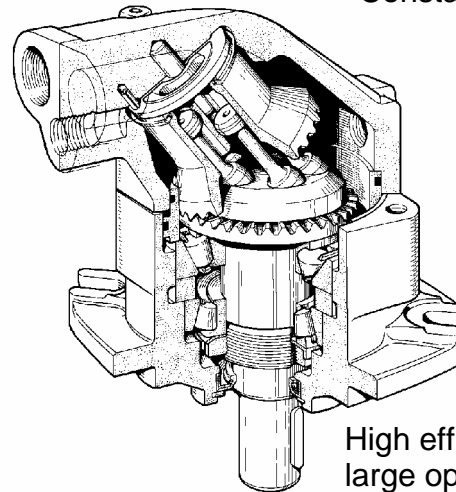

In variable models typically large 8°-25° control angle (up to 40°)

Up to 400 bar

High efficiency at large operational area



Hydraulic cylinders

Convert hydraulic power into mechanical power

Construction types:

- single acting
- double acting

Both operate on positive displacement principle

Terminology

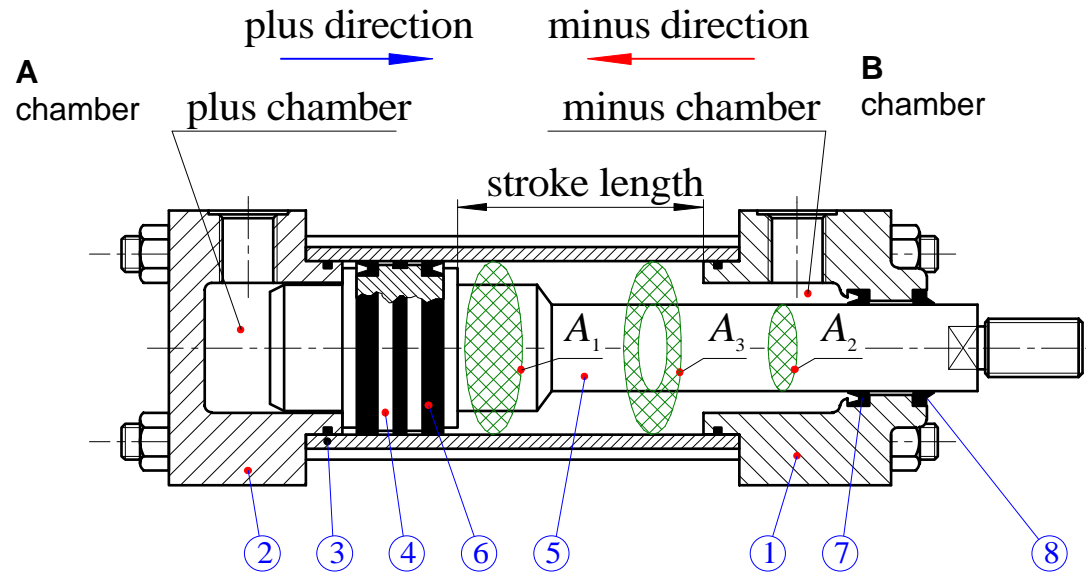

- | | | |
|--------------------|--------------------|--------------------------|
| 1. Head with inlet | 2. Cap with inlet | 3. Cylinder tube |
| 4. Piston | 5. Piston rod | |
| 6. Piston seals | 7. Piston rod seal | 8. Piston rod wiper seal |

Plunger cylinder integrated in reach truck's mast

Single acting cylinders

Operate hydraulically to only one direction

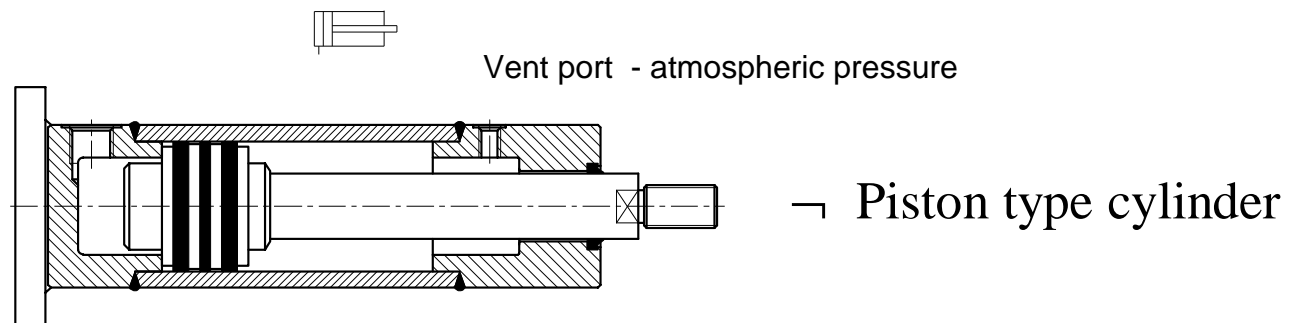

<http://www.rocla.com/en/products/roclas-humanic2-reach-trucks>



Plunger cylinder ®

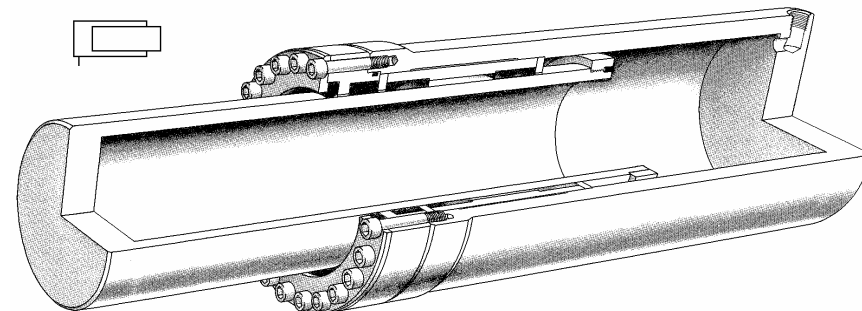

These models are single acting

Telescopic cylinder

Variable speed

- the largest piston starts (the least pressure need)
- the smallest piston is the last (the highest pressure need)

Used in dump trailers etc.



a

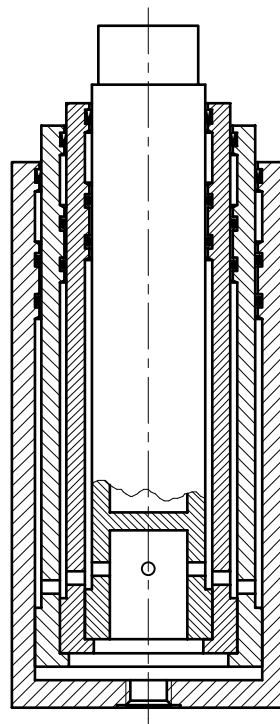

b

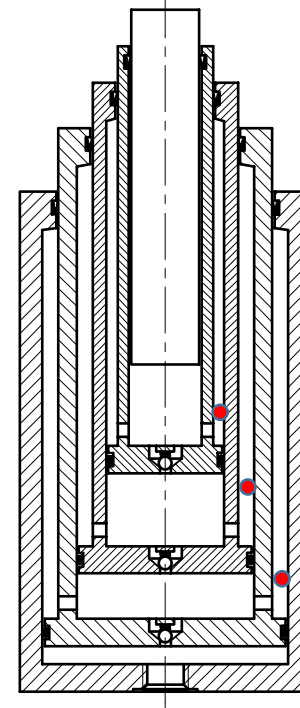

Constant speed telescopic cylinder
All the pistons move at the same time

The movement of a piston forces the fluid from the space between the adjacent cylinders out to lift the next piston

http://www.nurmihydro.fi/products_akipit.html

Double acting cylinders

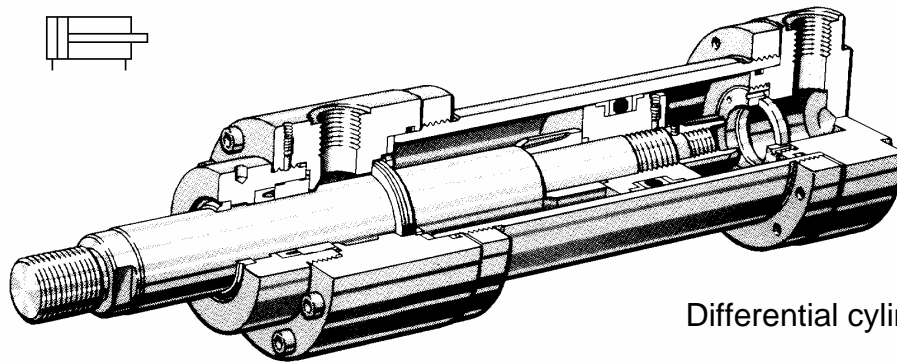
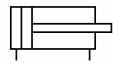

Differential cylinder



Single piston rod



Double piston rod
Symmetric cylinder

®

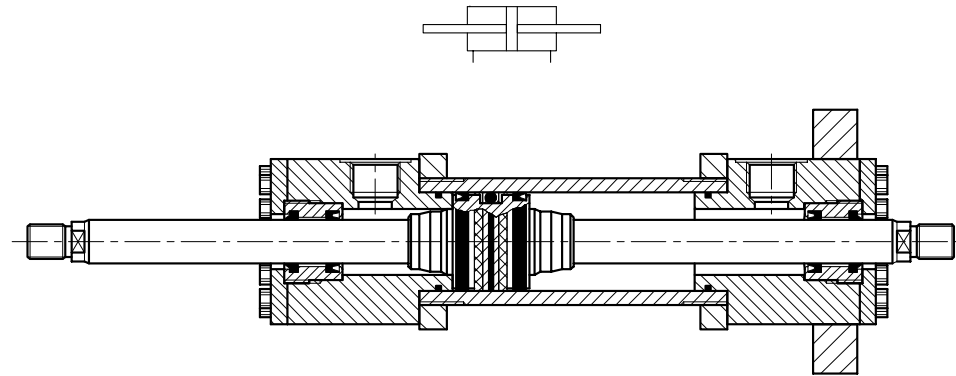

Telescopic cylinder

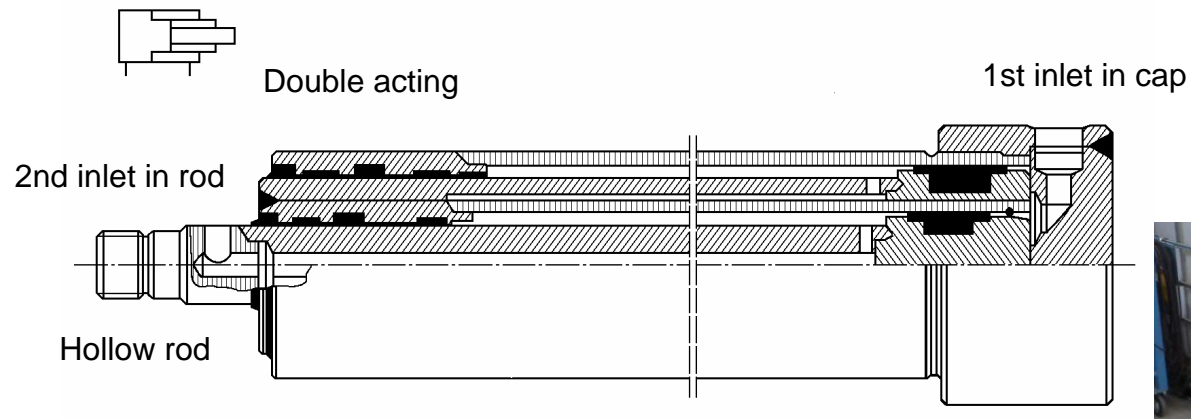

hydraulicpower.fi

Characteristics of cylinders

Theoretic pressure demand $p_{\text{theor, in}} \times A_{\text{in}} = F + p_{\text{out}} \times A_{\text{out}}$

Theoretic flow demand $q_{V, \text{in, theor}} = A_{\text{in}} \times v$

Quasi-static process
Hydraulic variables do not change

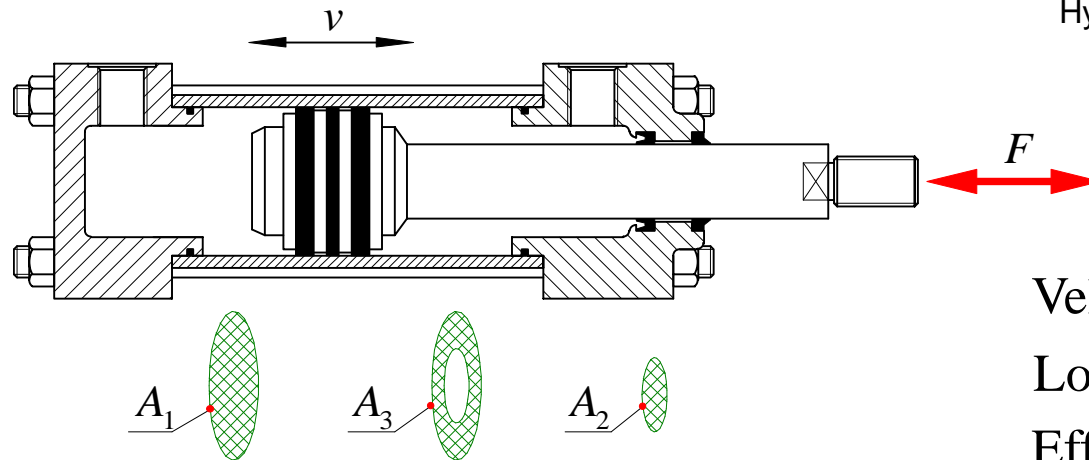

Velocity v [m/s]

Load force F [N]

Effective piston area A [m²]

Reality

Small minor losses
(pressure losses)
in inlets

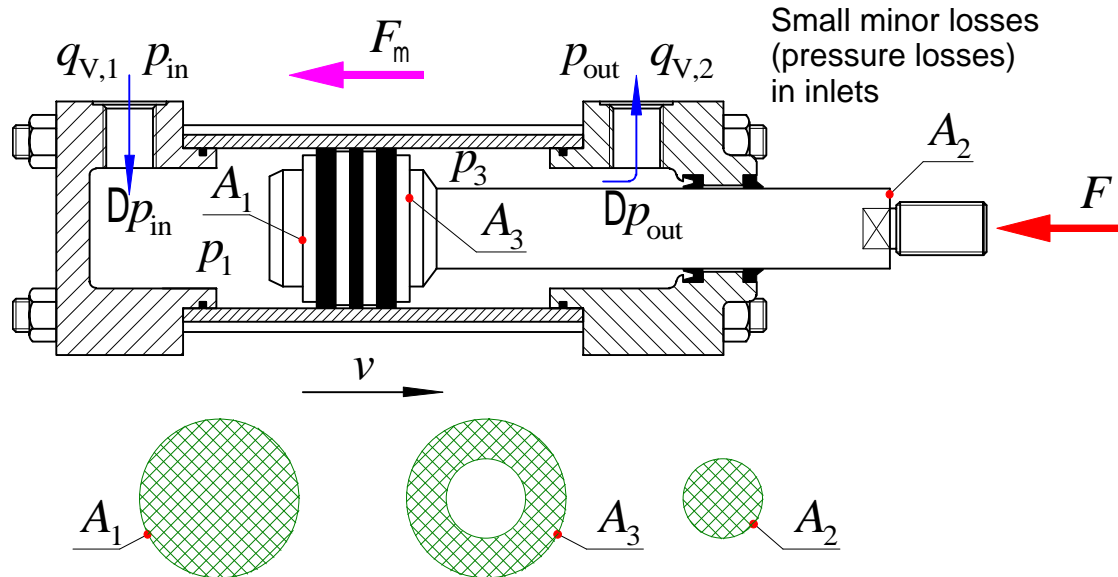

Small minor losses
(pressure losses)
in inlets

Example case:
plus-direction movement,
opposing force

Friction – hydromechanical efficiency h_{hm}

Leakage – volumetric efficiency h_v

Efficiencies in cylinder case are quite unclear
It would be better to use in calculations
- Friction forces
- Leakage flow rates
instead

Pressure

Example case:
plus-direction movement,
opposing force

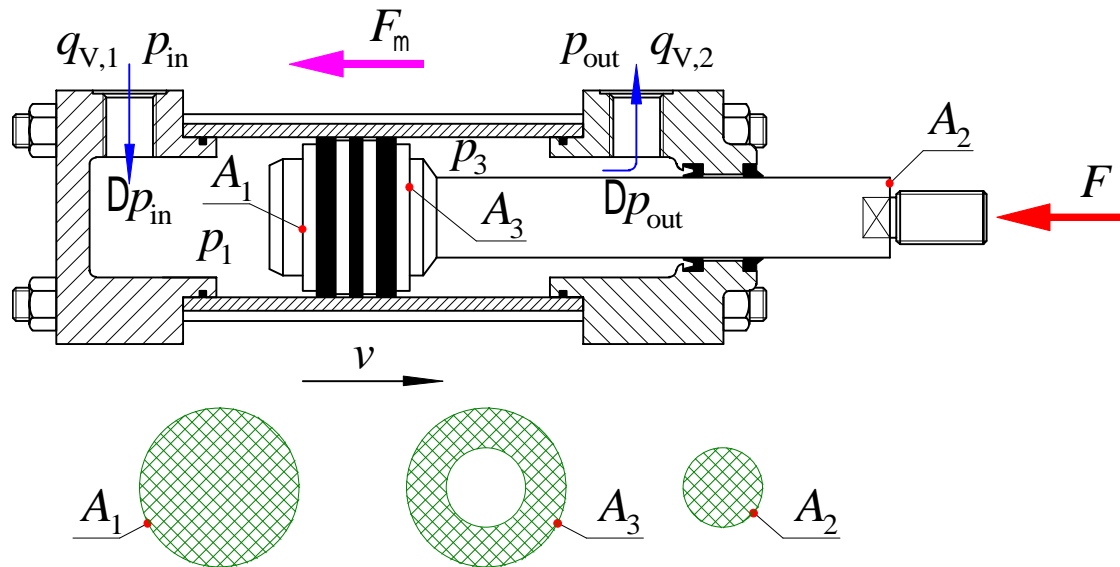

Actual A chamber pressure \Rightarrow force Actual B chamber pressure \Rightarrow force

Force equation $p_{in} \times A_1 - Dp_{in} \times A_1 = p_{out} \times A_3 + Dp_{out} \times A_3 + F + F_{\mu}$ Friction force (opposing movement)

Load force

Force equation in general form

Flow OUT increases the actual chamber pressure because of minor loss

$$p_{\text{real, in}} \times A_{\text{in}} - Dp_{\text{in}} \times A_{\text{in}} = F + F_{\mu} + p_{\text{out}} \times A_{\text{out}} + Dp_{\text{out}} \times A_{\text{out}}$$

Flow IN decreases the actual chamber pressure because of minor loss

Actual pressure demand

$$p_{\text{real, in}} = \frac{F + F_{\mu} + p_{\text{out}} \times A_{\text{out}} + Dp_{\text{out}} \times A_{\text{out}} + Dp_{\text{in}} \times A_{\text{in}}}{A_{\text{in}}}$$

In efficiency form

$$p_{\text{real, in}} = \frac{F}{A_{\text{in}} \times \eta_{\text{hm}}} + p_{\text{out}} \times \frac{A_{\text{out}}}{A_{\text{in}}}$$

Correct or not?
Hydromechanical efficiency
depends on what?

Flow

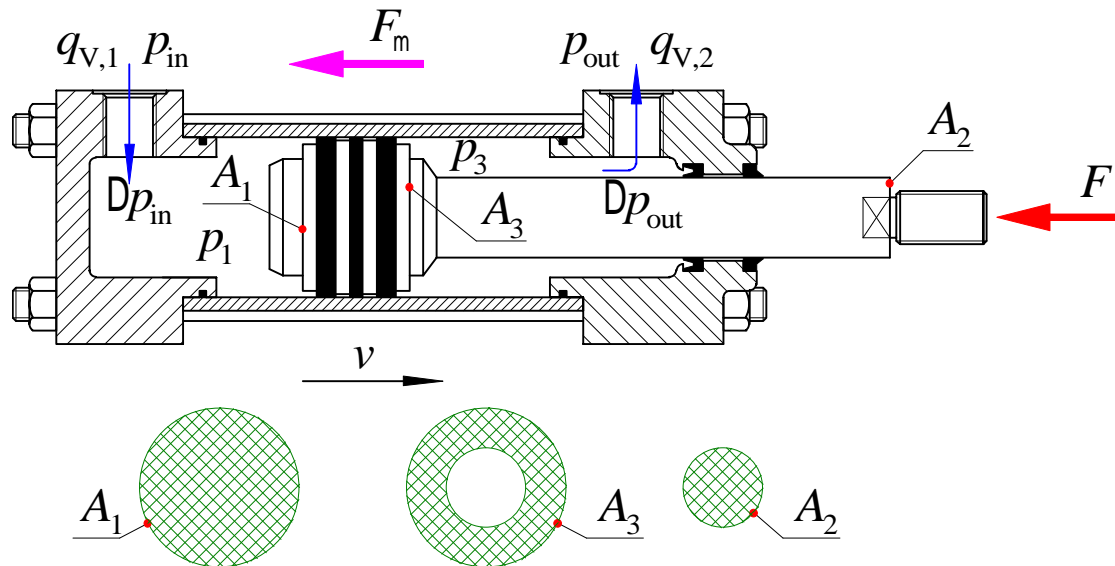

Example case:
plus-direction movement,
opposing force

Actual flow demand $q_{V,in,real} = \frac{A_{in} > v}{h_v}$

Volumetric efficiency depends on the leakages
What if pressure p_3 is higher than p_1 ?
Unclear!

Power

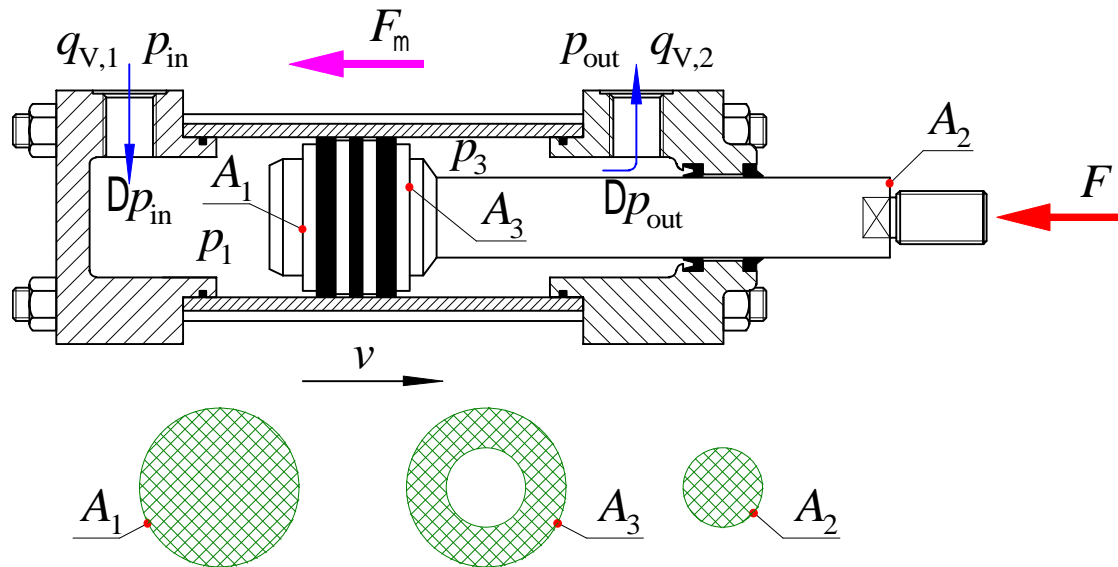

Example case:
plus-direction movement,
opposing force

Power demand of external force $P_{\text{mech}} = F \cdot v$

Theoretic power demand

$$P_{\text{theor}} = q_{V,\text{in}} \times c_p \times p_{\text{in}} - \frac{A_{\text{out}}}{A_{\text{in}}} \times p_{\text{out}} \frac{\dot{V}}{\dot{V}} = F \times v$$

Actual power demand

$$P_{\text{real}} = q_{V,\text{in}} \times c_p \times p_{\text{in}} - \frac{A_{\text{out}}}{A_{\text{in}}} \times p_{\text{out}} \frac{\dot{V}}{\dot{V}} = \frac{F \times v}{h_t}$$

If there is meaningful leakage, both the volumetric efficiency and total efficiency depend heavily on the velocity.
Normally leakage is very small and total efficiency depends merely on seal friction(s) and minor losses.

Loading and buckling of cylinders

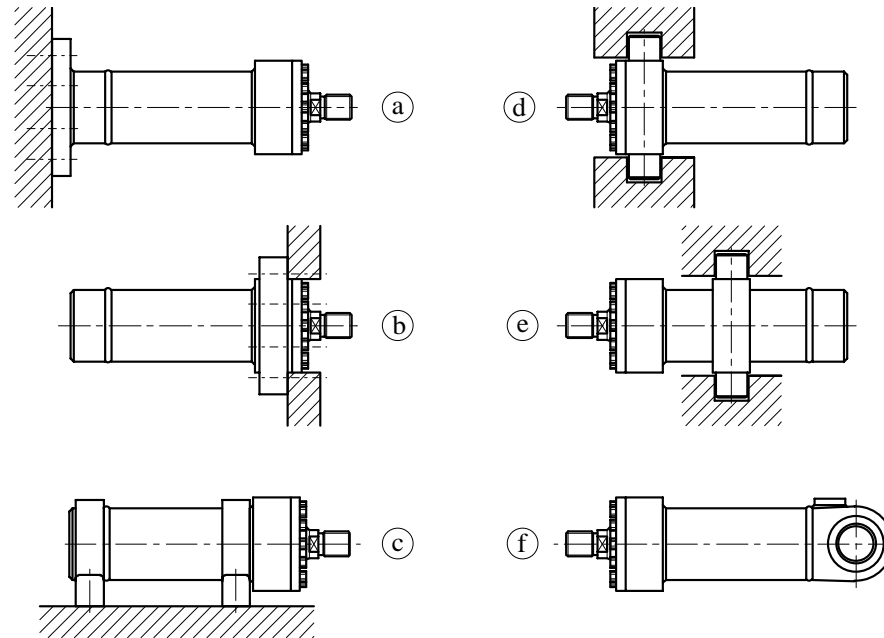

Loading only in parallel to the piston rod!

Mounting and buckling length

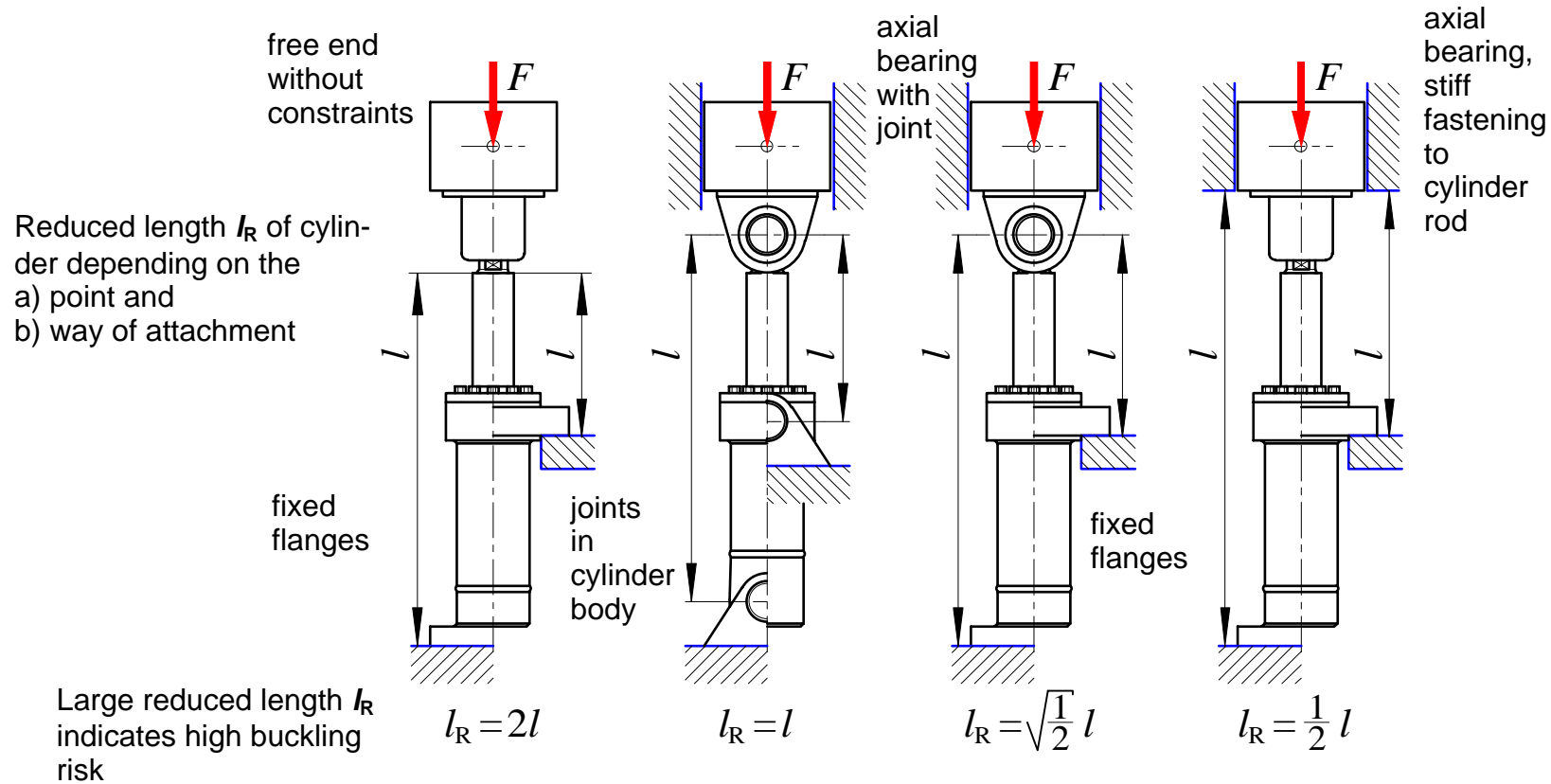

Buckling diagram

Safety factor typically 4

$$F = \frac{p^2 \times E_m \times I}{C_n \times l_R^2}$$

Young's modulus ~ 210 GPa for steel

E_m modulus of elasticity

I area moment of inertia $p d^4 / 64$

C_n safety factor

l_R effective length

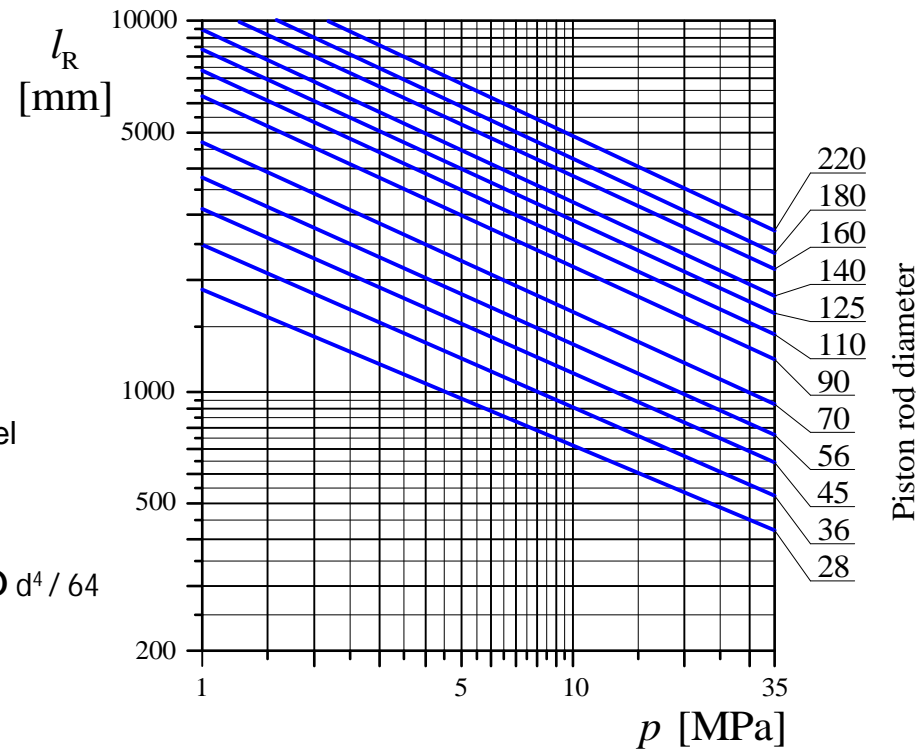

End cushioning of cylinders

At velocities
 $> 0.1 \text{ m/s}$

Flow area diminishes
 flow resistance
 increases the deeper
 the rod end is in the
 flow channel

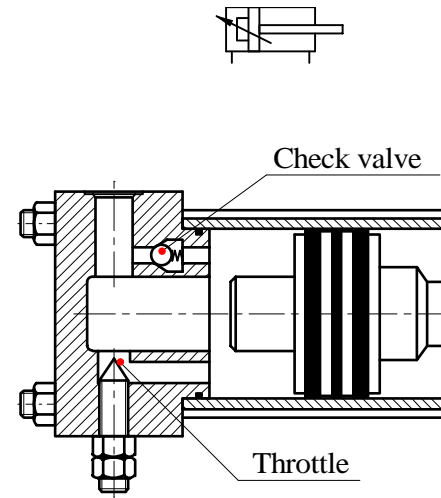
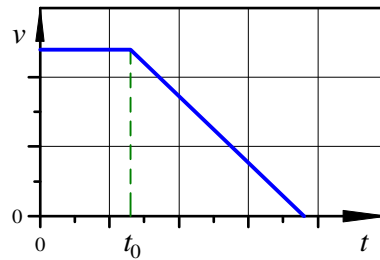
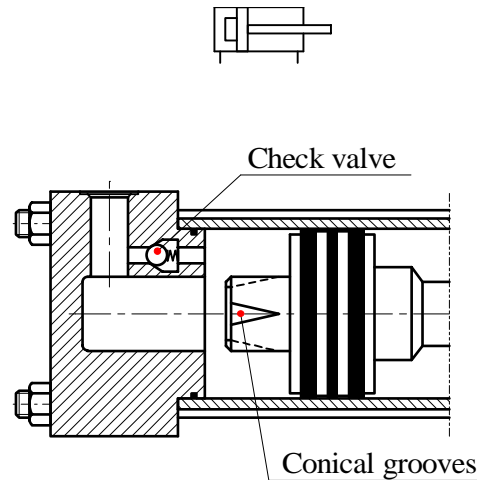

Flow area and flow
 resistance remains the
 same as the rod end gets
 into the flow channel
 Flow resistance is ad-
 justable

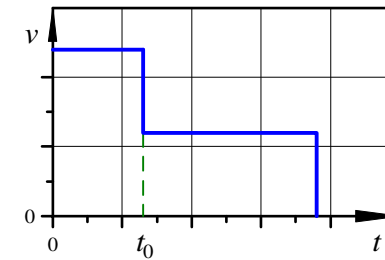

Torque motors

Convert hydraulic power into mechanical power

Rotation angle restricted, generally $< 360^\circ$

Construction types:

- vane
- piston

Both operate on positive displacement principle

Total efficiency max. $h_t \gg 0.6 - 0.86$

Torque max. $T \gg 10000 - 20000 (- 300000) \text{ Nm}$

Vane type

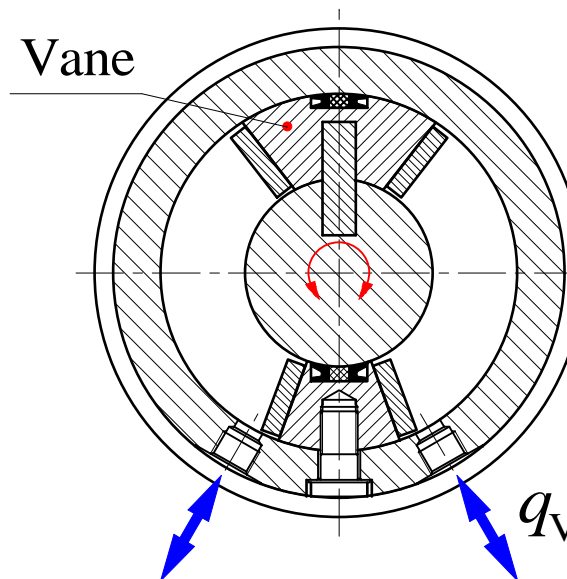
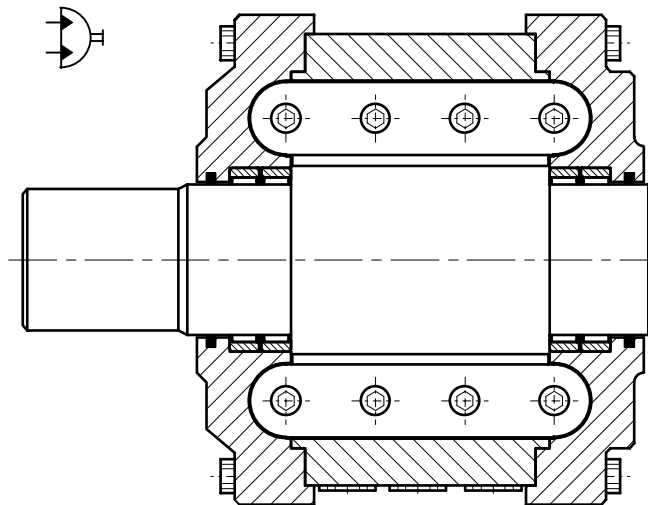

Maximum rotation angle $\sim 320^\circ$

With end cushioning $\sim 240^\circ$

Uneven pressure distribution causes high bearing loads

With 2 vane structure higher torques and pressure forces can be compensated \Rightarrow

smaller turning angle $\sim 170^\circ$

Constant torque

Leakage reduces total efficiency

Maximum $\sim 72\%$

Piston type

Gear type:

Screw gear

Crank mechanism

Cogwheel gear

Linear movement produced by piston is transformed into rotational by using two (2) screw gear mechanisms

- On the outer surface of piston
- On the inner surface of piston

The rotation angle can be up to 720°

Maximum pressure is about 100 bars
Efficiency is limited by leakages and friction in the gear
Constant torque
Maximum efficiency is about 62%

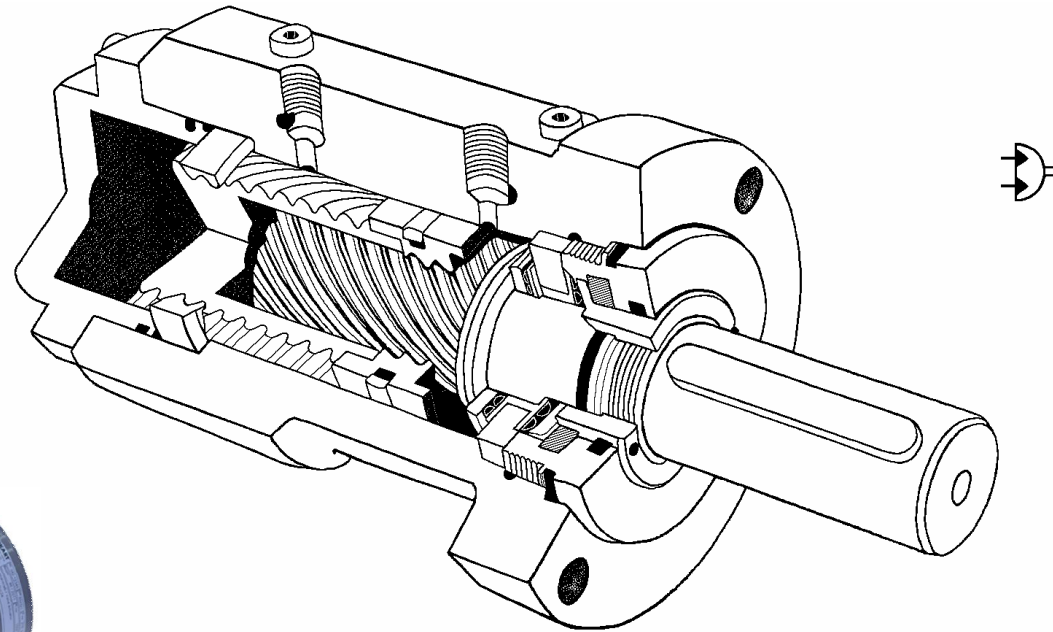

Screw gear
Crank mechanism
Cogwheel gear

Two pistons in parallel to have operation in two directions

Torque is not constant

- maximum in the middle

- only about 2/3 of the maximum near the ends

Turning angle about 100°

Maximum pressures 100 - 150 bar

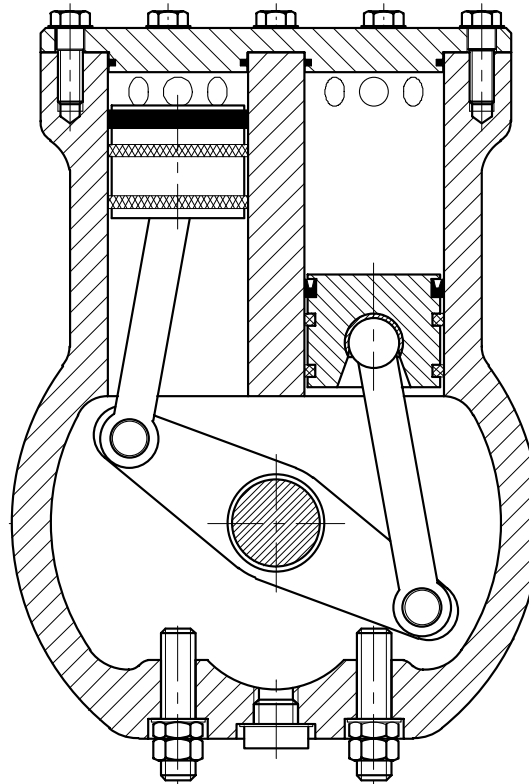

Torque motors

Screw gear
Crank mechanism
Cogwheel gear

Linear movement is converted into rotational with cogwheel mechanism
The rotation angles are typically 90° - 720°
Maximum pressure typically 160 bar
Efficiency can be about 86%

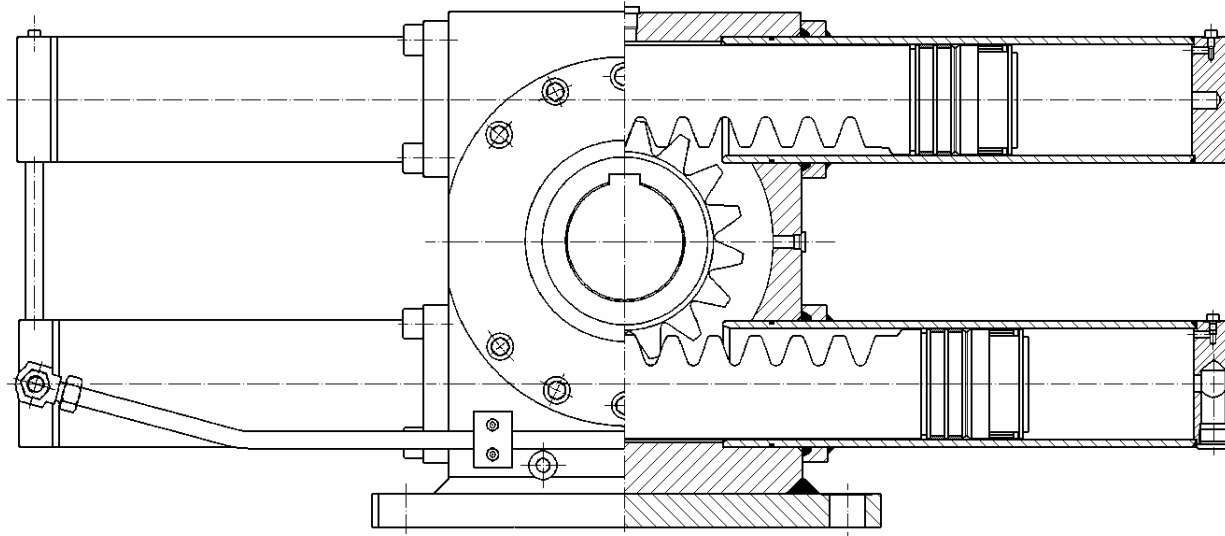

Rack and pinion structure



Torque motors



<https://www.fiellberg.fi/products/torque-motor/>

Screw gear
Crank mechanism
Cogwheel gear

Accumulators are superior **power sources**

Pressure accumulators

Store hydraulic energy
by utilizing the
compressibility of gas
(nitrogen) Piston accumulator

To activate the accumulator the system
pressure has to exceed accumulator's
precharge pressure (p_1 in the figure))

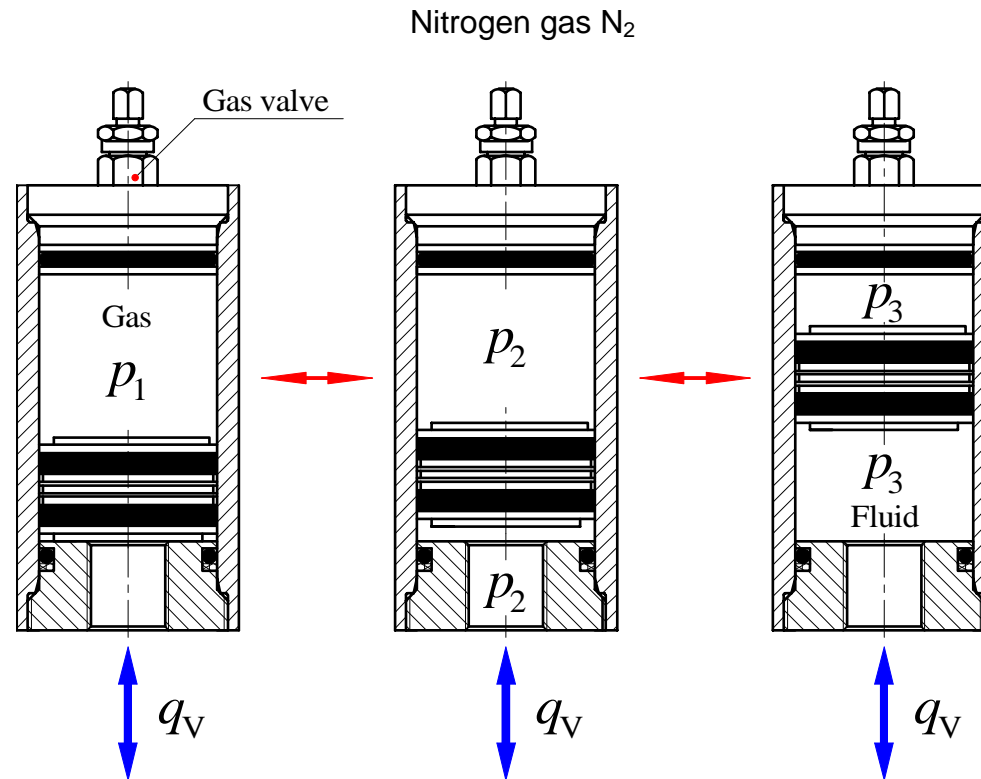

Construction and characteristics

Construction types:

- bladder
- diaphragm
- piston

Nominal volumes $V \gg 0.1 - 600 \times 10^{-3} \text{ m}^3$

Charging and de-charging flows max. $q_V \gg 120 - 140 \times 10^{-3} \text{ m}^3/\text{s}$



Gas inside the bladder
Fluid outside

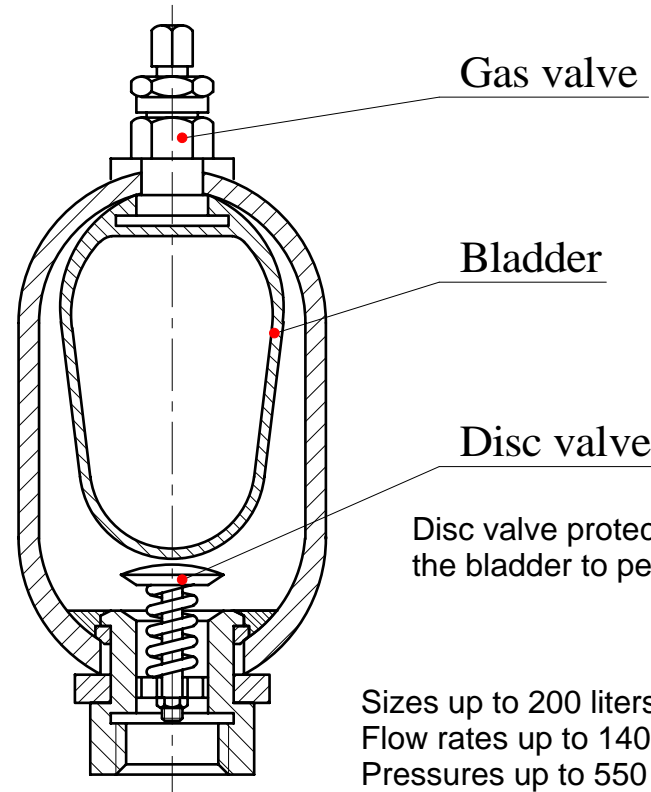

Disc valve protects the bladder and prevents the bladder to penetrate out

Sizes up to 200 liters
Flow rates up to 140 l/s (!)
Pressures up to 550 bar

Bladder
Diaphragm
Piston



Membrane accumulators are often used for damping of hydraulic oscillations
Sizes up to 5 liters
Flow rates up to 140 l/s (!)
Pressures up to 500 bar

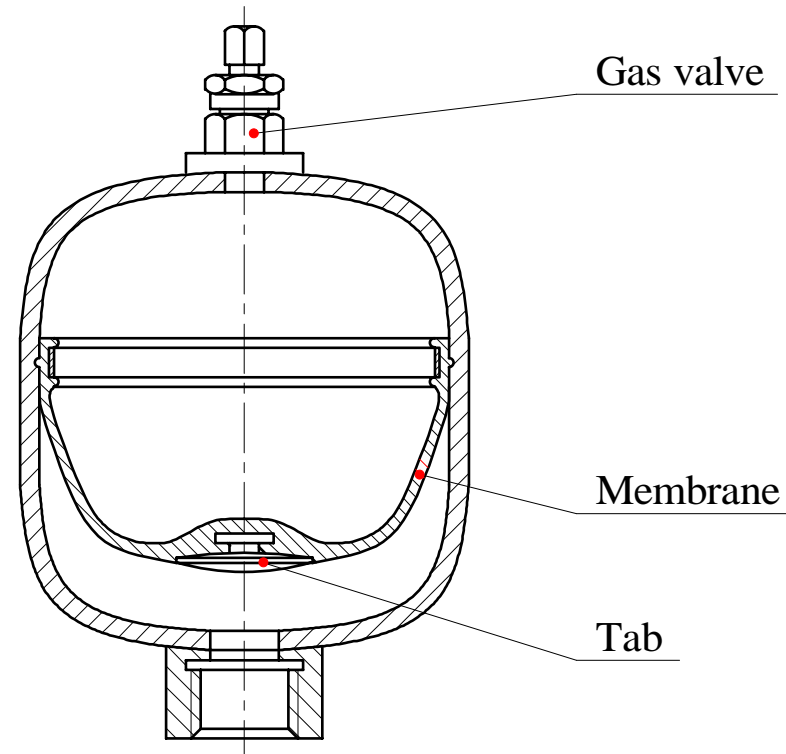

Bladder
Diaphragm (aka Membrane)
Piston

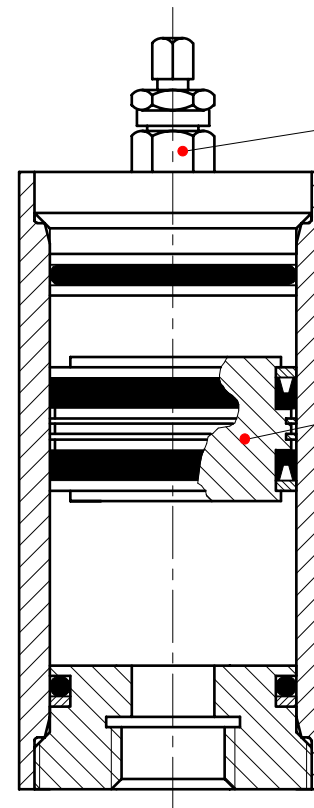

Gas valve

Piston

<https://www.hydrroll.com/fi/>

Bladder
Diaphragm
Piston

Sizes up to 600 liters
Flow rates up to 120 l/s (!)
Pressures up to 400 bar

Seal friction may decrease the efficiency (at low pressures)

Gas volume can be increased by connecting additional gas bottles to accumulators

Application examples

- Flow source
- Upkeep of pressure
- Levelling of flow fluctuation
- Suppression of pressure shocks
- Energy storage for exceptional situations
- Storing of external energy
- Levelling of volume changes
- Levelling of shock-like loadings of actuators

Equation of state for ideal gas can be used for simple calculations
Real gas equations for accurate results (especially at high pressures)

compression - storage (1 minute) - expansion

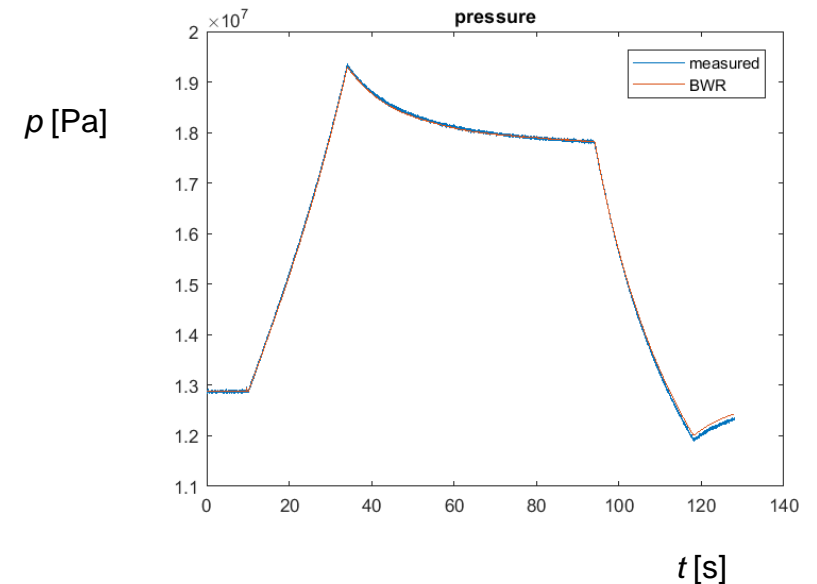

Measured and simulated pressure response indicates the effects of thermal losses especially during storage phase

Flow source

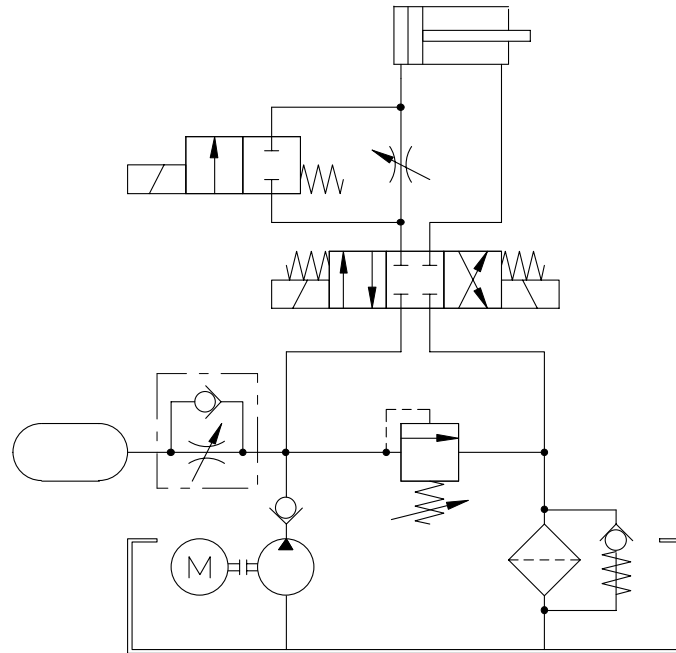

Upkeep of pressure

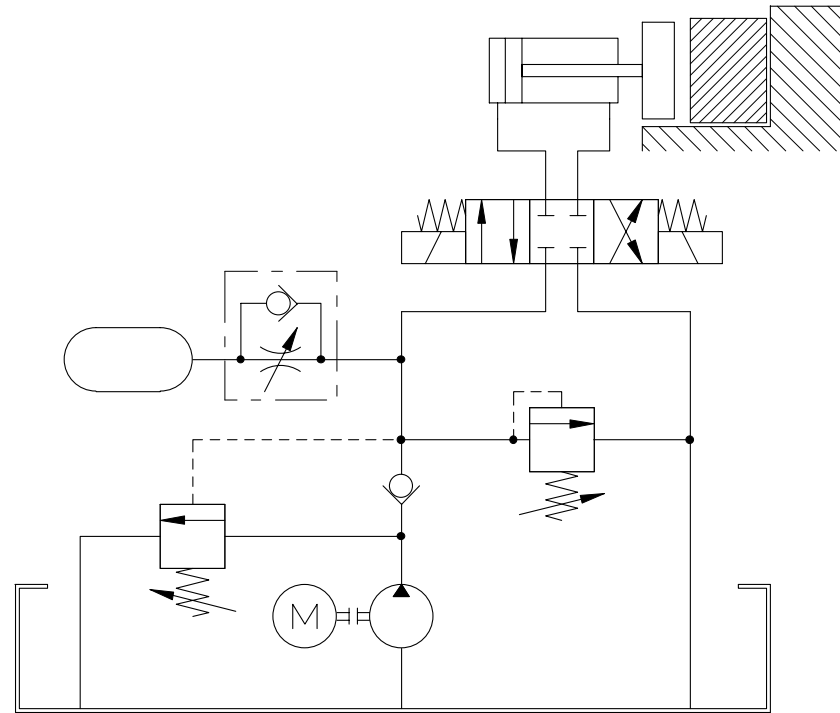

Levelling of flow fluctuation

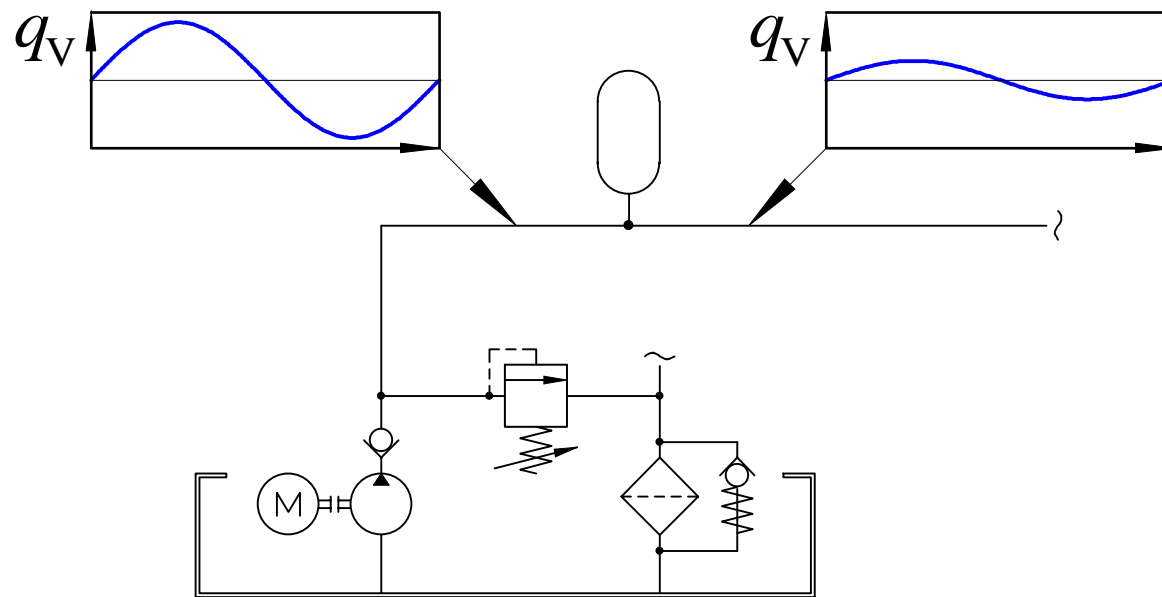

Pressure pulsation amplitude as function of frequency

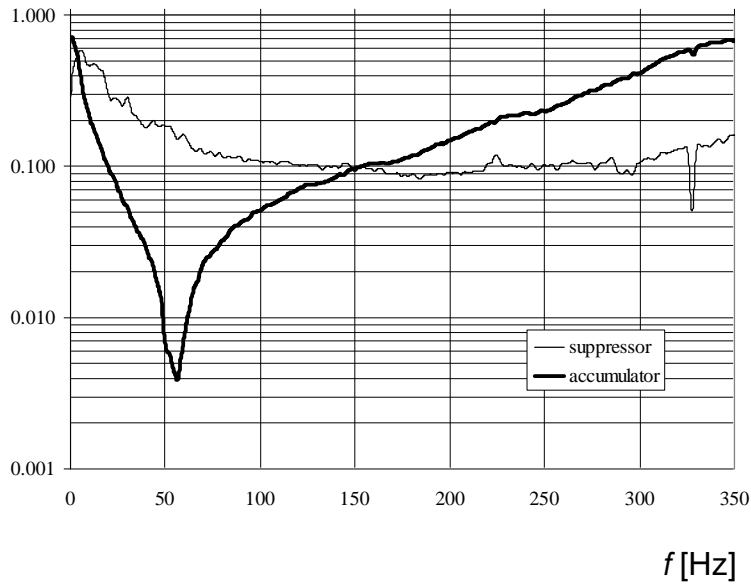

Inline suppressor ®

Membrane accumulator's
 a) elastic gas volume (hydraulic capacitance) and
 b) inlet throat
 form together a hydraulic resonator capable of damping
 pressure oscillations at frequencies 0 - 100 - 300 Hz

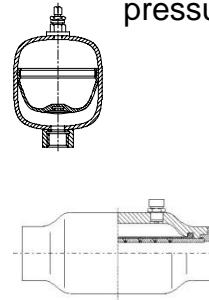

Example:
 Levelling of
 flow fluctuation

Special accumulators "pulsation and noise dampers" or "inline suppressors" have wider frequency range

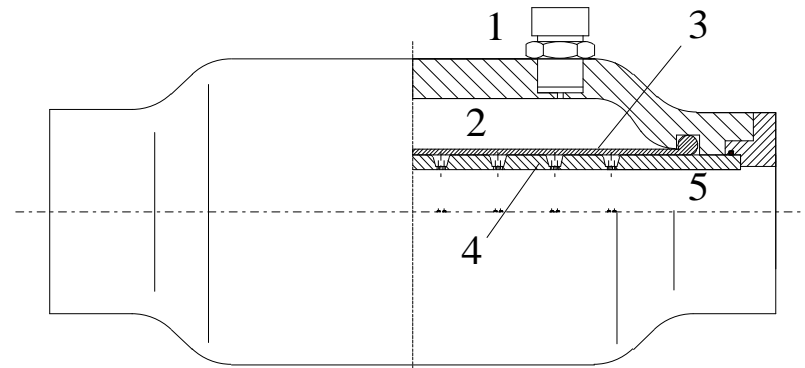

<http://www.saip.it/EN/Products/Standard%20accumulators/with%20bladder/SPM%20type>

Suppression of pressure shocks

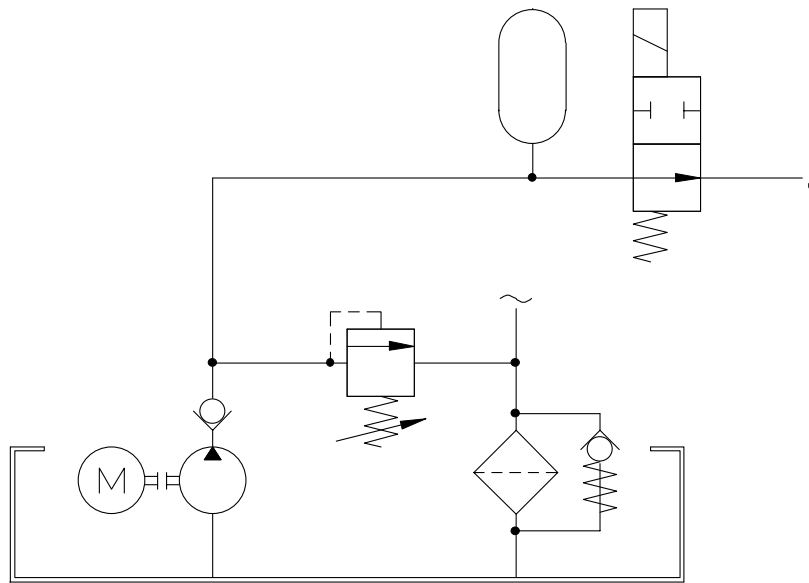

Energy storage for exceptional situations

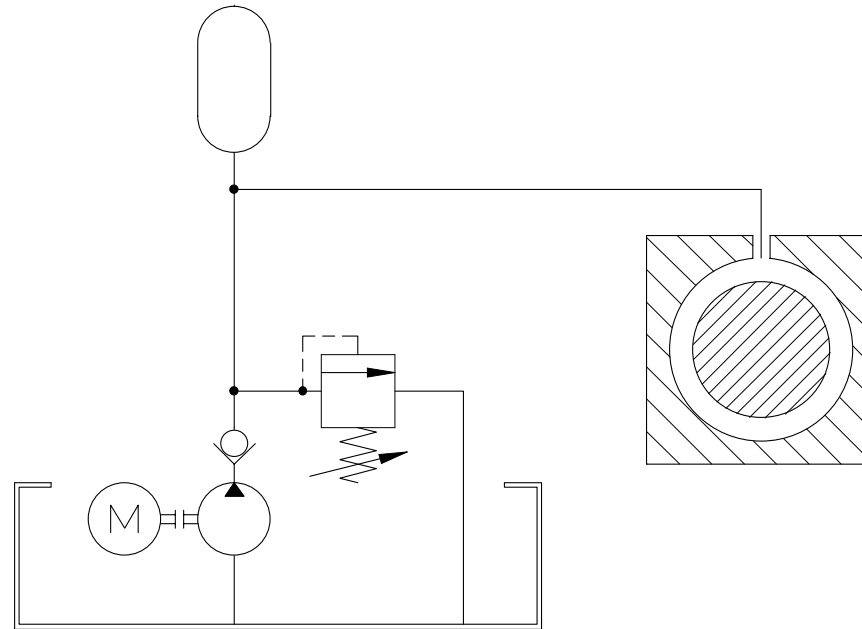

Storing of external energy

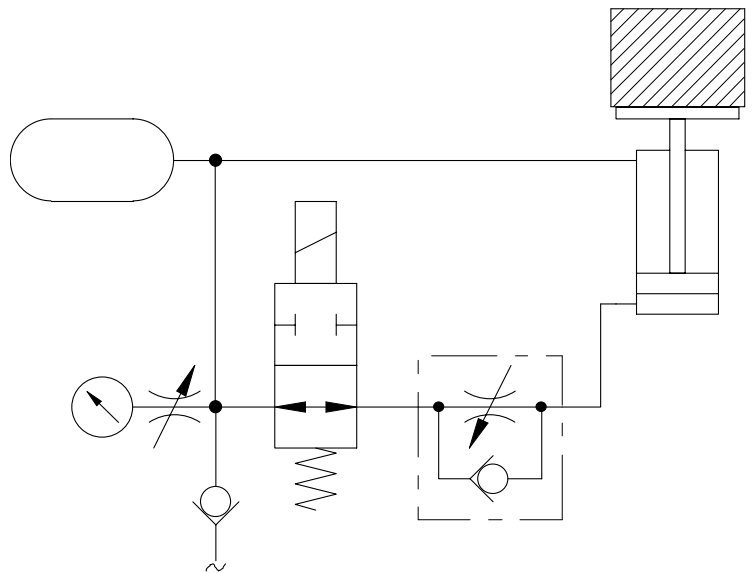

Lecture themes - Recap

Pump's task in hydraulic system?

Converting hydraulic power into

- rotational movement?

- linear movement?

Operation principle of hydrostatic power converters?

Utilization possibilities of pressure accumulators?