



Aalto University
School of Engineering

MEC-E5003

FLUID POWER BASICS

Study Year 2018 - 2019

Fluid conditioning

- Filters
- Heat exchangers
- Extra:
 - The reservoir
 - Piping components

Lecture themes

Does the cleanliness of the fluid matter, i.e., should the “trash” be removed from the system?

Warmth is nice, but how about the temperature?

(Reservoir, a storage for fluid, or is it also something else?)

(How to conduct fluid from pumps to valves and actuators?)

Filters

Maintain the cleanliness of fluid

! Impurities cause ~70–80 % of all malfunctions of hydraulic systems !

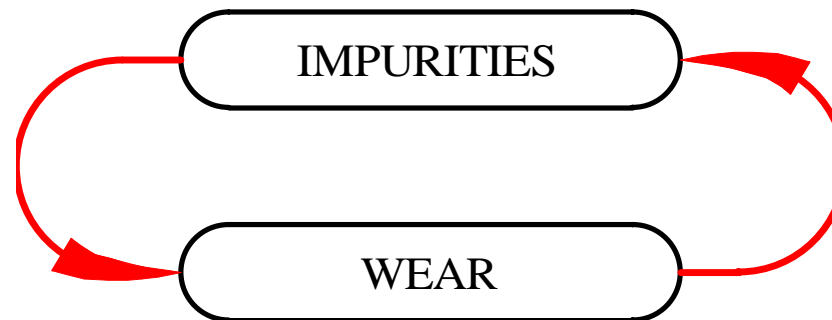

Vicious circle

Impacts of the impurities

- weaken the properties of fluid
- shorten the useful life of fluid
- speed up the wear of the system
- impact on the behaviour and the reliability of the system

Impurity sources

- initial impurities of the system
- impurities of the environment
- impurities originating from the system itself

Impurity types

- solid particles
- liquids (either dissolved in base fluid or as separate agent)
- gases (either dissolved in base fluid or as separate agent)

* 50 - 55% of malfunctions are due to solid impurities
* 20 - 25% of malfunctions are due to water and air

Solid impurities

Effects on the system depends on

- material
- hardness
- size
- shape
- quantity

Effects

- sudden damages or malfunctions (large particles)
- slow wear (size of particles $\sim \leq$ clearance size)

Liquid impurities

Most noteworthy of these is **water**

- ill effects are minor if water is **dissolved** in to base fluid
- when **not dissolved**, water has significant ill effects
 - reacts with base fluid
 - **wear** of the system speeds up (reduced lubricity)
 - danger of **corrosion and rust**

Gaseous impurities

Most noteworthy of these is **air**

- ill effects are minor if air is **dissolved** in to base fluid
- when **not dissolved**, air has significant ill effects
 - reacts with base fluid (oxidation, ageing)
 - **compressibility** of the fluid increases
 - danger of **cavitation**

Wear caused by solid impurities

System parameters contributing to the ill effects of solid impurities

- flow velocity of the fluid
- pressure level of the system
- clearances of the components

Wear mechanisms

- abrasion
- erosion
- surface fatigue failure

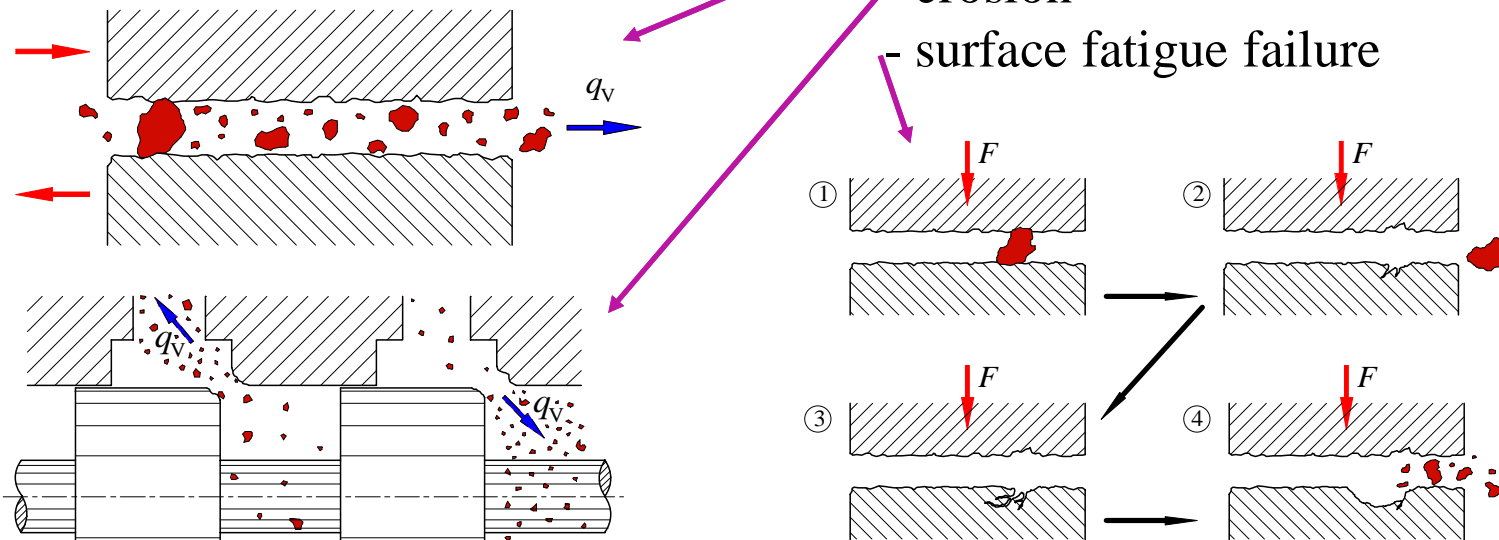

Wear is caused by particles with sizes of approximately the same magnitude as, or smaller than, the clearances. Larger particles cause jamming (of, e.g., spools) or blocking (of small flow channels).

Harmful particle sizes

Component/gap	Clearance [mm]
Gear pump/motor	
tip of tooth – chamber wall	0,5- 5
end of gear – side plate	0,5- 5
Vane pump/motor	
tip of vane – chamber wall	0,5- 5
side of vane – side plate	5- 25
Piston pump/motor	
piston – cylinder wall	5- 40
valve plate – cylinder block	0,5- 10
Spool valve	
spool – valve housing	5- 25
Servo valve	
spool – valve housing	2- 8
nozzle – flapper	20- 70
nozzle (diameter)	100- 400
Hydrostatic bearing	1- 30

Effects of wear

- increase of clearance sizes
 - increase of friction, leak and power loss in components
- increase of quantity of impurities
 - wear speed increases

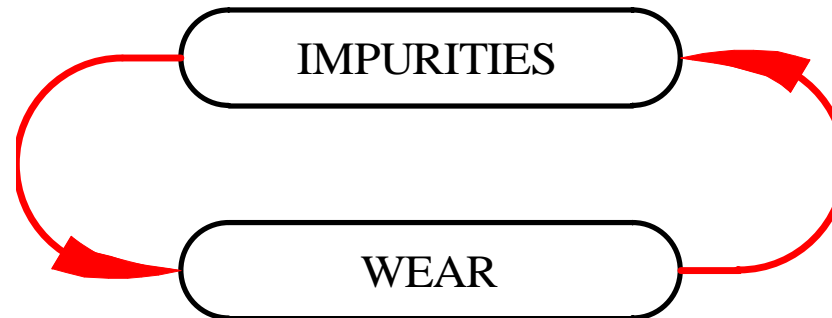

Summary

Sources, types and effects of impurities

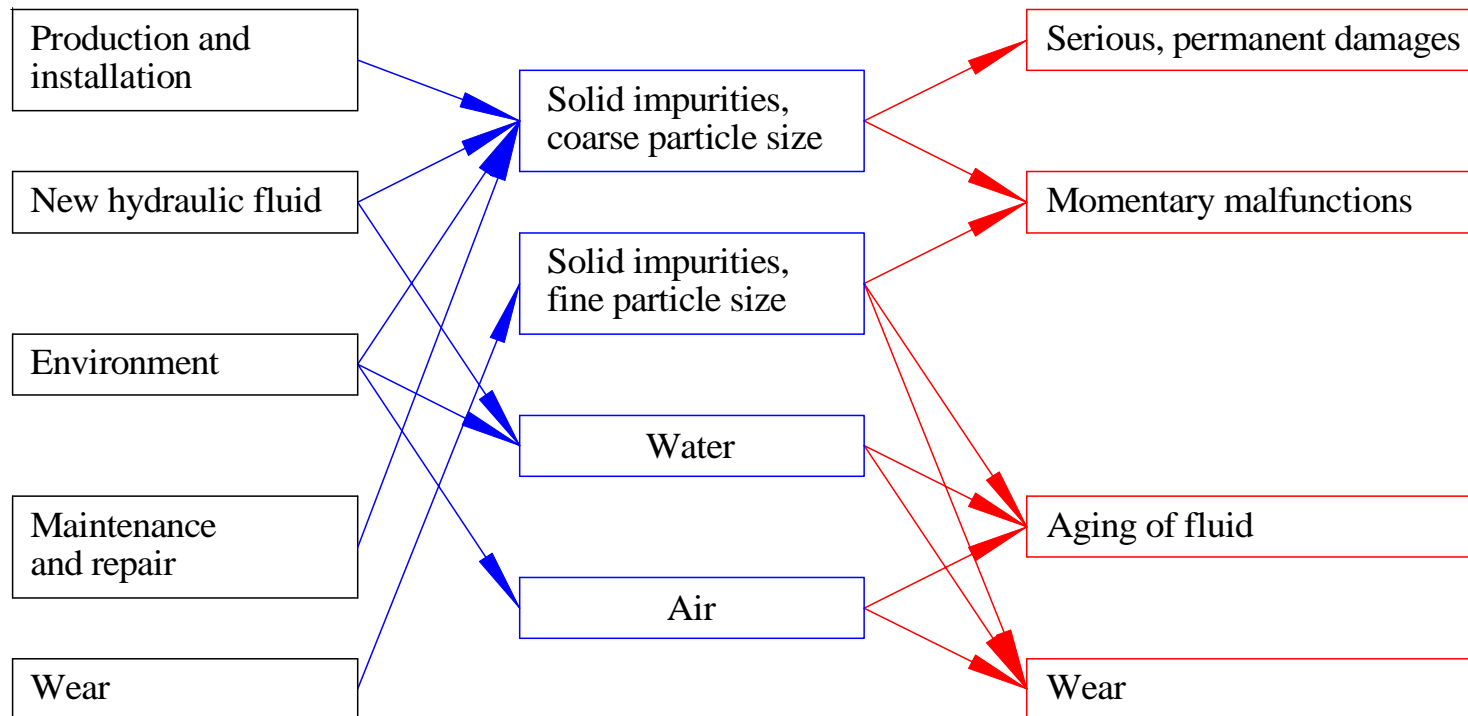

Ok, so what amounts and sizes of solid impurities (particles) can be allowed?
Before giving recommendations, we need a standardized way to express this => the cleanliness class

Cleanliness class

Denotes quantity and size distribution of solid impurities.

Describes

- what is **allowed** for a component or a system, or
- what has been **measured** from the system (by sampling the fluid)

Standards

- ISO 4406
- SAE AS 4059 (Society of Automotive Engineers, Aerospace Standard)
- NAS 1638 (National Aerospace Standard)

OUTDATED

NAS 1638

Cleanliness class	Maximum Contamination Count (particles / 100 ml)				
	5- 15 mm	15- 25 mm	25- 50 mm	50- 100 mm	>100 mm
00	125	22	4	1	0
0	250	44	8	2	0
1	500	89	16	3	1
2	1000	178	32	6	1
3	2000	356	63	11	2
4	4000	712	126	22	4
5	8000	1425	253	45	8
6	16 000	2850	506	90	16
7	32 000	5700	1012	180	32
8	64 000	11 400	2025	360	64
9	128 000	22 800	4050	720	128
10	256 000	45 600	8100	1440	256
11	512 000	91 200	16 200	2880	512
12	1 024 000	182 400	32 400	5760	1024

Determination in five size classes, but system class number is determined according to the class giving poorest result (usually the class 5–15 mm)

The result for all five size classes is lumped into one cleanliness number. (compare to ISO 4406 => one cleanliness number for each size class (of which there are three), p. 19.

Compare to ISO 4406

SAE AS 4059

Count type	Particle size [mm]					
I	> 1	> 5	> 15	> 25	> 50	> 100
II	> 4	> 6	> 14	> 21	> 38	> 70
Cleanliness class	Size code and maximum contamination count* (particles / 100 ml)					
	A	B	C	D	E	F
000	195	76	14	3	1	0
00	390	152	27	5	1	0
0	780	304	54	10	2	0
1	1560	609	109	20	4	1
2	3120	1217	217	39	7	1
3	6250	2432	432	76	13	2
4	1,25×10 ⁴	4864	864	152	26	4
5	2,50×10 ⁴	9731	1731	306	53	8
6	5,00×10 ⁴	1,95×10 ⁴	3462	612	106	16
7	10,0×10 ⁴	3,89×10 ⁴	6924	1224	212	32
8	20,0×10 ⁴	7,79×10 ⁴	1,39×10 ⁴	2449	424	64
9	40,0×10 ⁴	15,6×10 ⁴	2,77×10 ⁴	4898	848	128
10	80,0×10 ⁴	31,1×10 ⁴	5,54×10 ⁴	9796	1696	256
11	1,60×10 ⁶	62,3×10 ⁴	11,1×10 ⁴	1,96×10 ⁴	3392	512
12	3,20×10 ⁶	1,25×10 ⁶	22,2×10 ⁴	3,92×10 ⁴	6784	1024

Determination in one or more size classes (the particle sizes vary according to measuring equipment and the standard used in calibration of the equipment)

Several ways to report the result, e.g.

6B (one particle size class)

7B/6C/5D (three size classes)

Replaces the outdated NAS 1638

SAE AS 4059

Counting the number of particles, two main methods

Type I: Calculation either by

- automatic particle counter (calibrated along ISO 4402)
- microscope (particle size is determined as the maximum measure of the particle)

Type II: Calculation either by

- automatic particle counter (calibrated along ISO 11171)
- electron microscope (particle size is determined as the diameter of a circle whose area corresponds to the plane projected area of the particle)

Cleanliness class	Maximum contamination count (particles / 1 ml)		=2 x lower limit
	Lower limit	Upper limit	
< 1	0,00	0,01	
1	0,01	0,02	
2	0,02	0,04	
3	0,04	0,08	
4	0,08	0,16	
5	0,16	0,32	
6	0,32	0,64	
7	0,64	1,3	
8	1,3	2,5	
9	2,5	5	
10	5	10	
11	10	20	
12	20	40	
13	40	80	
14	80	160	
15	160	320	
16	320	640	
17	640	1300	
18	1300	2500	
19	2500	5000	
20	5000	10 ⁴	
21	10 ⁴	2x10 ⁴	
22	2x10 ⁴	4x10 ⁴	
23	4x10 ⁴	8x10 ⁴	
24	8x10 ⁴	1,6x10 ⁵	
25	1,6x10 ⁵	3,2x10 ⁵	
26	3,2x10 ⁵	6,4x10 ⁵	
27	6,4x10 ⁵	1,3x10 ⁶	
28	1,3x10 ⁶	2,5x10 ⁶	
> 28	2,5x10 ⁶		

ISO 4406

Determination by automatic **particle counter**
(**three size classes**)

≥ 4 μm

≥ 6 μm

≥ 14 μm

→ three part class code, e.g., 24/21/15

Each size class gets its own cleanliness class number.

Determination by **microscope**
(**two size classes**)

≥ 5 μm

≥ 15 μm

→ three part class code, e.g., -/21/15

hyphen => counted 'by microscope'

Examples of cleanliness recommendations/requirements

Cleanliness class requirements of components

Component	Recommendation for Cleanliness class			* Calculation either by - automatic particle counter (calibr. ISO 11171) - electron microscope
	ISO 4406	NAS 1638	SAE AS 4059*	
Directional control valve	21/18/15	10	11A/9B/9C	<div style="border: 1px solid red; padding: 5px; width: fit-content;">for pressure level 160 - 200 bar</div> <div style="border: 1px solid red; padding: 5px; width: fit-content; margin-top: 10px;">Check with component manufacturers for actual values!</div>
Flow valve	21/18/15	10	11A/9B/9C	
Pressure valve, controlling	21/18/15	10	11A/9B/9C	
Cylinder	21/18/15	10	11A/9B/9C	
Gear pump / motor	21/18/15	10	11A/9B/9C	
Piston pump / motor	20/18/15	9	10A/9B/9C	
Vane pump / motor	20/17/14	9	10A/8B/8C	
Proportional valve	20/16/13	9	10A/7B/7C	
Servoproportional valve	18/16/13	8	8A/7B/7C	
Servo valve	17/14/11	7	7A/5B/5C	
Servo cylinder	17/14/11	7	7A/5B/5C	

Sensitive components (small clearances) require cleaner fluid

Effect of system pressure level on the required cleanliness class
(in relation to the table on previous slide)

Level of operating pressure	Change in Cleanliness class
0- 100 bar	3 classes weaker
100- 160 bar	1 class weaker
160- 210 bar	No change
210- 250 bar	1 class stronger
250- 315 bar	2 classes stronger
315- 420 bar	3 classes stronger
420- 500 bar	4 classes stronger
500- 630 bar	5 classes stronger

Cleanliness class requirements of systems

System type	Recommendation for Cleanliness class		
	ISO 4406	NAS 1638	SAE AS 4059*
Low pressure systems with conventional valves	24/17/14	9 @ 11	-/8B/7C
High pressure systems with conventional valves	21/16/13	7 @ 9	11A/11B/7C
Proportional valve systems	20/15/12	6 @ 7	10A/6B/6C
Servoproportional valve systems	18/14/11	5 @ 6	8A/5B/5C
Servo valve systems	18/13/10	4 @ 5	8A/4B/4C
Highly sensitive high power systems	16/11/9	3 @ 4	6A/2B/3C

* Calculation either by
 - automatic particle counter
 (calibr. ISO 11171)
 - electron microscope

Realizing a certain cleanliness class requires filtration on a certain level

Filter

Operating principles of filter elements

Surface filtering

- Thin sheets (folded)
- Cellulose or woven fibers (plastic or steel)
- 'Constant' pore size

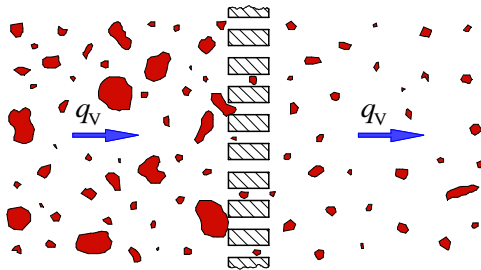

Depth filtering

- Thick fiber mat or compacted/sintered metal granulates
- Cellulose, glass fibres, metal fibres or granulates
- Passages of non-constant size
- Clogging takes longer than with surface filters

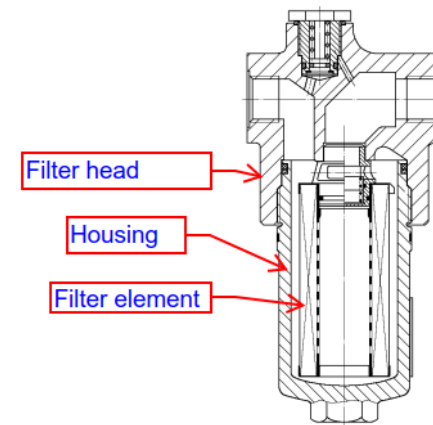
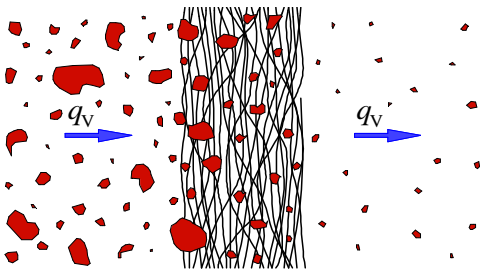

Parts

- filter element (figure)
- housing (also see slide 29)
- accessories

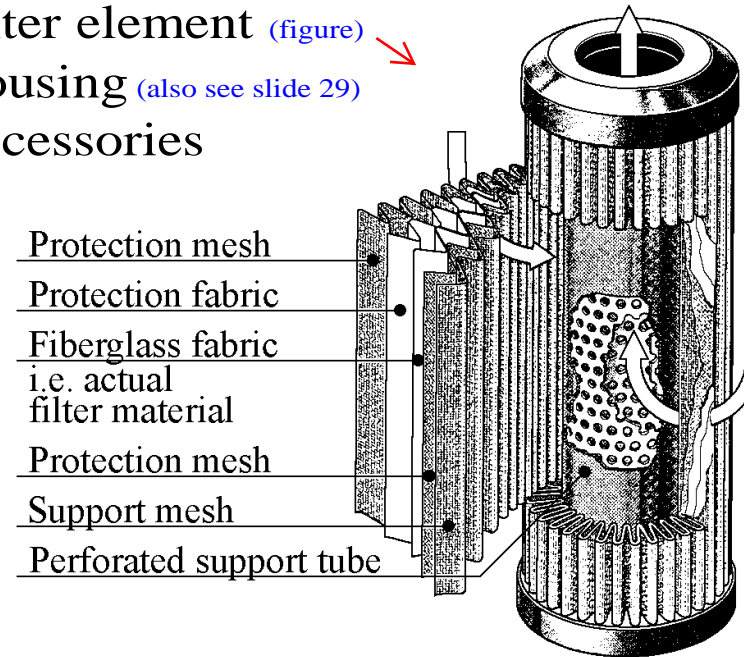

How to characterize the performance of the filter

$\beta_x = 2 \Rightarrow 50\%$ of particles > size x are removed
 $\beta_x = 20 \Rightarrow 95\%$ of particles > size x are removed
 $\beta_x = 75 \Rightarrow 98.6\%$ of particles > size x are removed
 $\beta_x = 100 \Rightarrow 99\%$ of particles > size x are removed

Expressing filtration efficiency

“Filtration grade”

b-ratio (“filtration ratio” or “degree of separation”)

- number of particles (before filter N_1 / after filter N_2)
- ISO 4572 (Multi-pass-test)
- x denotes the size (equal or larger) of calculated particles

$$b_x = \frac{N_1}{N_2}$$

Absolute filtration grade

- largest spherical particle (mm) that passes the filter
- removes **99 %** of the particles greater than the announced size, $b_x \leq 100$

Nominal filtration grade

- removes **95 %** of the particles greater than the announced size, $b_x \leq 20$
- note: determination **not standardized** (depends on filter manufacturer)

Expressing filtration efficiency

Filtration efficiency S_x of filter for certain particle size

$$S_x = \frac{c_1 - c_2}{c_1} \times 100\%$$

How great a percentage of size x particles that the filter will remove

in theory, but

Just a β value isn't enough
- the size x matters:
 $\beta_5 > 75$ (removes 98.7 %
of particles $> 5 \mu\text{m}$) is bet-
ter than $\beta_{10} > 75$.

Filtration rating x refers to the size of particles which the filter is able to remove from the fluid, but it does not absolutely describe the efficiency of the filter, since it is also affected by other factors.

See slide 27

Cleanliness class and filtration rating

Example of effect of filtration rating x on achievable cleanliness class

μm

**Typical ISO 4406 Cleanliness classes achievable with different filtration ratings
(class depends also on the conditions of system and environment)**

99.5 %

Filtration rating x $\beta_x \geq 200$	x	Typical ISO 4406 Cleanliness classes achievable with different filtration ratings (class depends also on the conditions of system and environment)												
	25													19/16/13 – 22/19/16
20												18/15/12 – 21/18/15		
15										17/14/11 – 20/17/14				
10								15/12/9 – 19/16/13						
5				12/9/6 – 17/14/11										
3		10/7/4 – 13/10/7												
		10/7/4	11/8/5	12/9/6	13/10/7	14/11/8	15/12/9	16/13/10	17/14/11	18/15/12	19/16/13	20/17/14	21/18/15	22/19/16

Other factors describing the properties of filters

- Contamination capacity (dirt-hold capacity)
- Collapse pressure
- Ripping pressure
- Fatigue resistance

Flow into filter element



- Collapse pressure

Flow out of filter element



- Ripping pressure

- Fatigue resistance

Repeated pressure fluctuations due to variations in flow rate



Amount (mass) of dirt that has been captured when the filter is clogged (at max pressure differential)



- Contamination capacity (dirt-hold capacity)

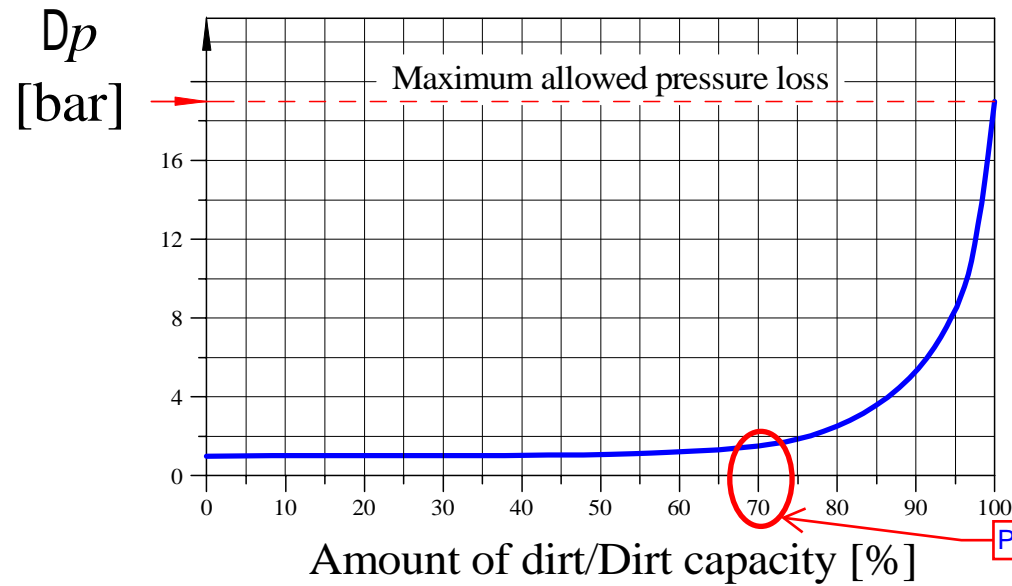

Pressure increase starts

Classification of filters in system

According to the task

- work filters
(1-6; maintain cleanliness level)
- protective filters (7-10)

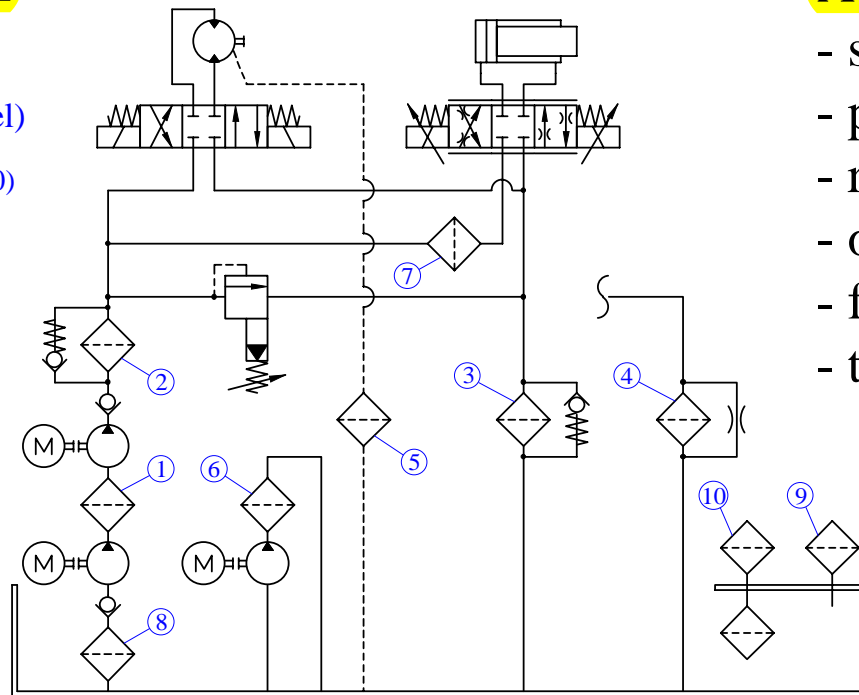

According to the location

- suction filters (8; beware of cavitation)
- pressure filters (eg, 2: before PRV)
- return line filters (3, 4, 5)
- offline filters (6)
- filling filter (10)
- tank breather filter (9)

- The filling&breather filter 10 is usually only a coarse mesh
 - Better to fill the tank through a separate filter corresponding to the required cleanliness level
 - Or use the system's own return filter

- If large flow rate variations in the return line => use variant 4 as cheaper solution (don't have to dimension for highest possible return flow, as for 3)

Filter types

Pressure filter

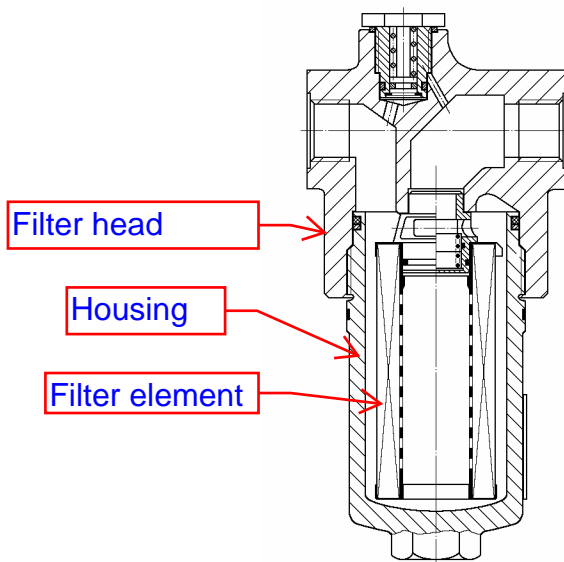

Return line filter

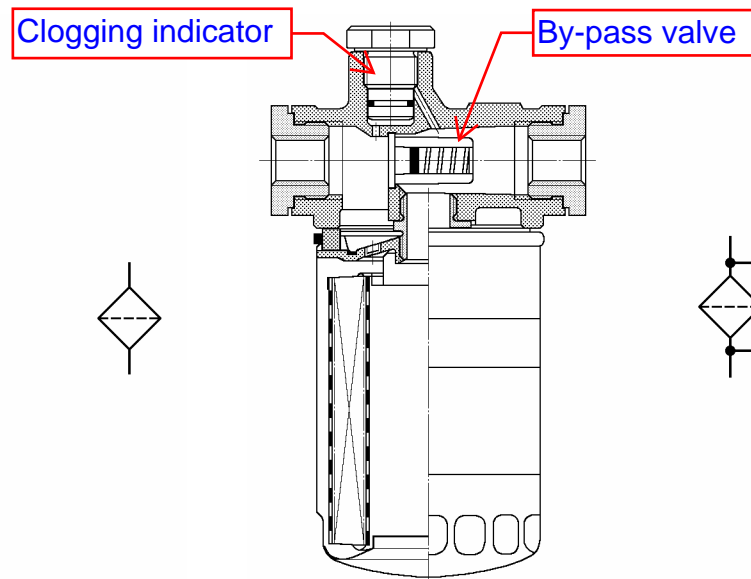

Filling filter and tank breather filter

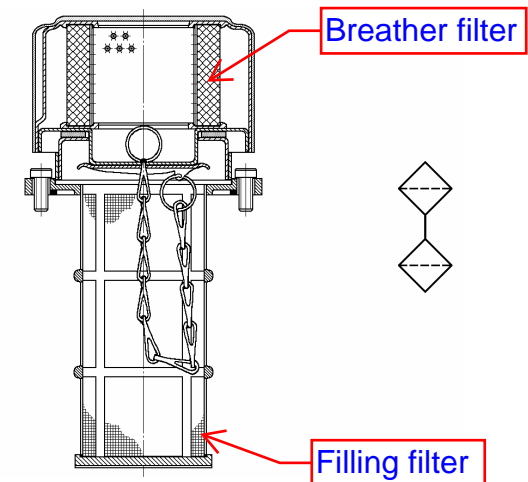

When the filter gets clogged, the by-pass valve protects the filter element from getting damaged by the pressure differential and re-releasing the dirt into the system.
(At start-up, there will also be an increased pressure differential because of higher viscosity.)

Filtration system

Filtration system

- consists of **several filters** (work filters and protective filters)
- prevents impurities from entering the system
- removes the impurities from the system

(Only one filter is usually not enough)

→ **Maintains the required cleanliness level**

The continuity of filtration effectivity and quality requires continuous maintenance of the filtration system.

Heat exchangers

Maintain/control the operating temperature of the fluid by

- cooling
- warming

In operating state of the system the viscosity of fluid should be in its optimum range (16–36 cSt) and decreasing under 10 cSt should be prevented (lubrication limit).

In starting state of the system the viscosity of the fluid should be lower than the highest value allowed to the system (defined by some component of the system, e.g., pump).

Cooler

Transfers heat embodied in the hydraulic fluid actively to coolant that is either

- air
- water

and thus away from the hydraulic fluid

The **cooling efficiency depends on**

- temperature difference between hydraulic fluid and coolant
- magnitude of coolant flow
- cooling area
- flow type (laminar or turbulent)

Cooler types



[Funke]

Air cooler

Core + fan

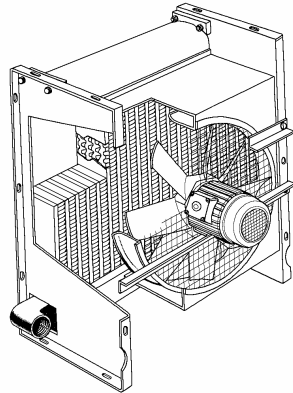

Water cooler, plate type

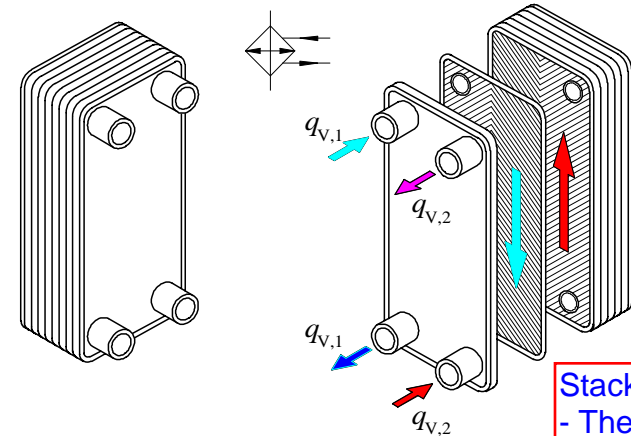

Stack of embossed plates
 - The flows are directed into the spacings between every other plate
 - $q_{v,1}$ = water
 - $q_{v,2}$ = hydraulic fluid
 - Counter flow

Water cooler, tube type

Cooling water passes through the pipes and the hydraulic fluid flows in the opposite direction surrounding the pipes.

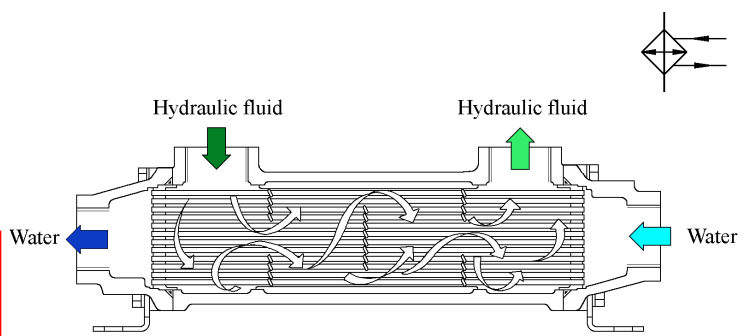

Cooler types

Water
cooler,
plate type

Arrangement
of hydraulic
fluid and
coolant
flow paths

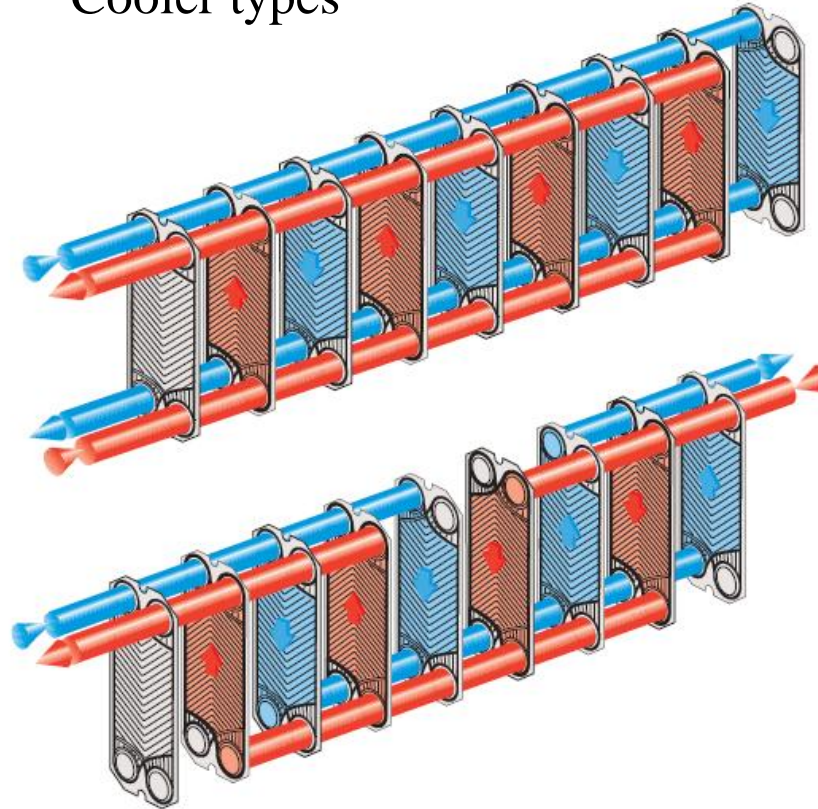

'Single-pass flow'

This configuration is most commonly used. [Funke]

'Multi-pass flow' (≥ 2)

In cases where there are small temperature differences between process fluid and coolant. [Funke]

Coolers

Air cooler

- availability of coolant good
- heat transfer capacity poor in relation to size
- large imminent environmental load (air flow, heat and noise)
- best suitability in mobile hydraulic systems

(working environment and industrial environment)

Water cooler

- availability and price of coolant
- heat transfer capacity good in relation to size
- minor imminent environmental load
- corrosion effect of water
- best suitability in fixed industrial hydraulic systems

Heaters

- Warm hydraulic fluid either
- directly
 - indirectly via transmitter fluid

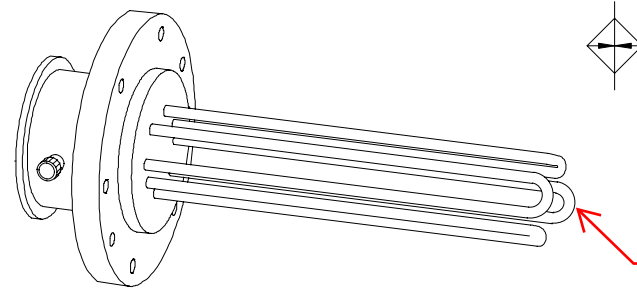

Types

- Immersion heater
- Circulation heater

Typical placement: horizontally in the tank

The heat is transferred to flowing fluid.

Resistor
(within shielding tube)

Heating power has to be restricted to avoid overheating and encrusting of the hydraulic fluid.

E.g., 20 kW/m² heating power for mineral oil if the oil flows, but this depends on the flow rate - in tanks, where the flow is slow, 7 kW/m² can be appropriate.

(Carbon) deposits

Coolers and heaters in system

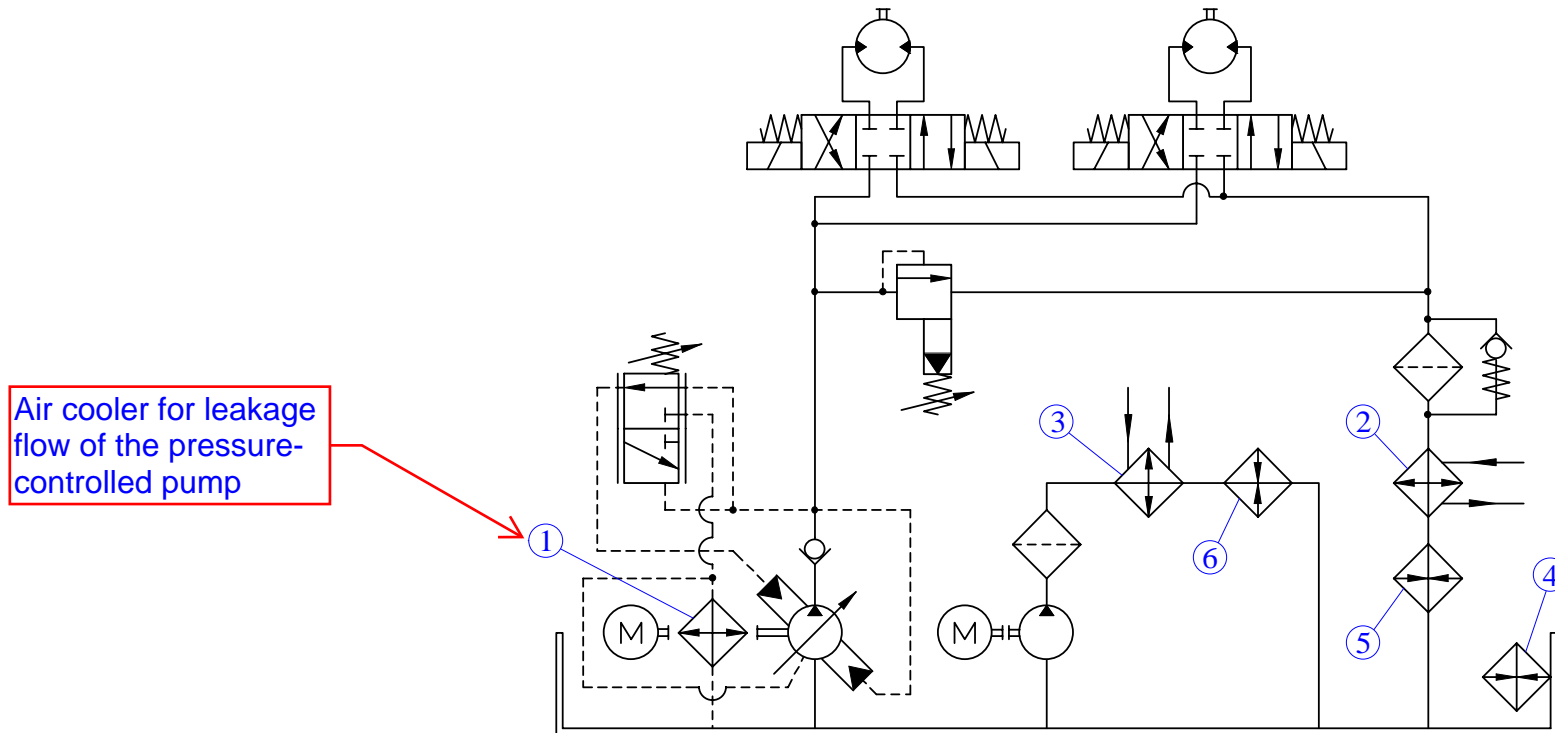

Air cooler for leakage flow of the pressure-controlled pump

- Coolers (2; in return line) and (3; in separate filtering circuit).
- Heater (4; in tank) is of the immersion type.
- Heaters (5; in return line) and (6; in the filtering circuit) are circulation heaters.

EXTRA

Reservoir (= tank)

Tasks of reservoir

- fluid storage for the system
- buffer leveling the differences between suction and return flows
- heat exchanger
- separator of the impurities of fluid
- installation base for system components

Size of reservoir

The fluid volume of reservoir is generally sized according to the average minute flow of the system pumps:

- In fixed industrial systems $V_{\text{reservoir}} = 2-5 \times q_{V,\text{pumps}}$

"50 l/min => 100 ... 250 litres"

- In mobile systems $V_{\text{reservoir}} = 1-2 \times q_{V,\text{pumps}}$

"50 l/min => 50 ... 100 litres"

In sizing of the reservoir also the following have to be considered

- momentary quantity changes of fluid in reservoir (buffer function)
- in case of system maintenance the fluid circulating in the system has to be fitted in the reservoir

Reservoir accessories

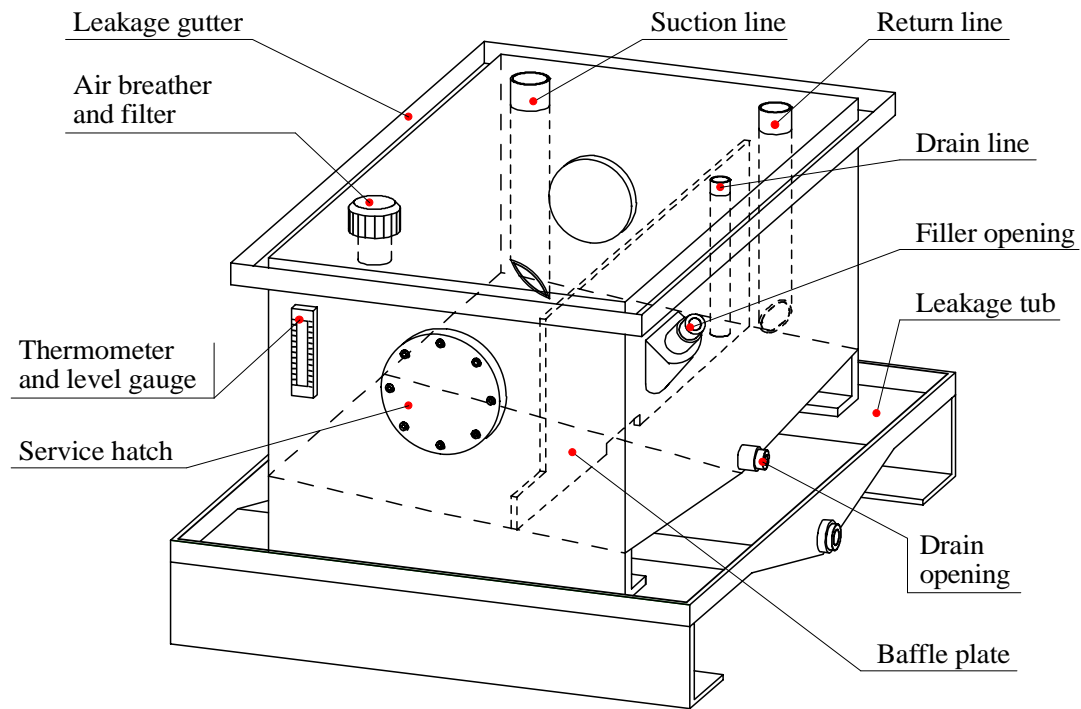

Slow down the flow in the tank in order to better remove heat as well as impurities and air.

Note also 45 degree cuts of pipes and a diffuser (on next slide) at end of the return pipe to increase the flow channel cross section and reduce the velocity of the flow.

Enhancing the functions of reservoir

Enhancing heat exchange

Enhancing impurities separation

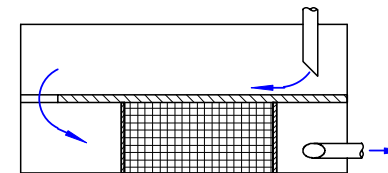
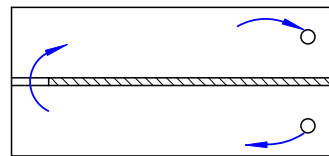
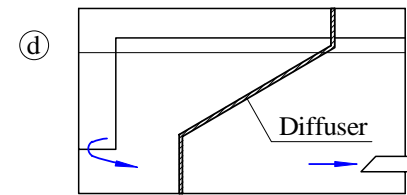
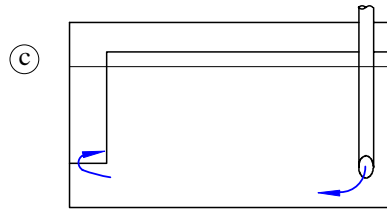
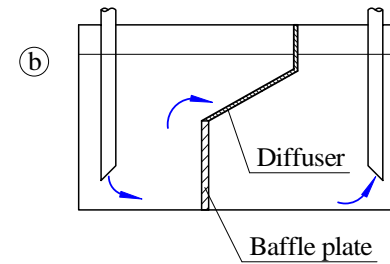
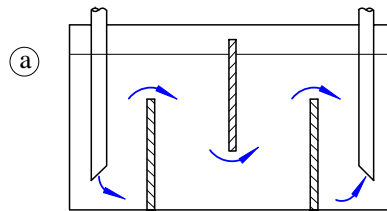

Diffuser mesh to enhance separation of air bubbles from oil

Positioning of flow channels in reservoir

The suction line should begin sufficiently below the surface, but also sufficiently above the bottom.

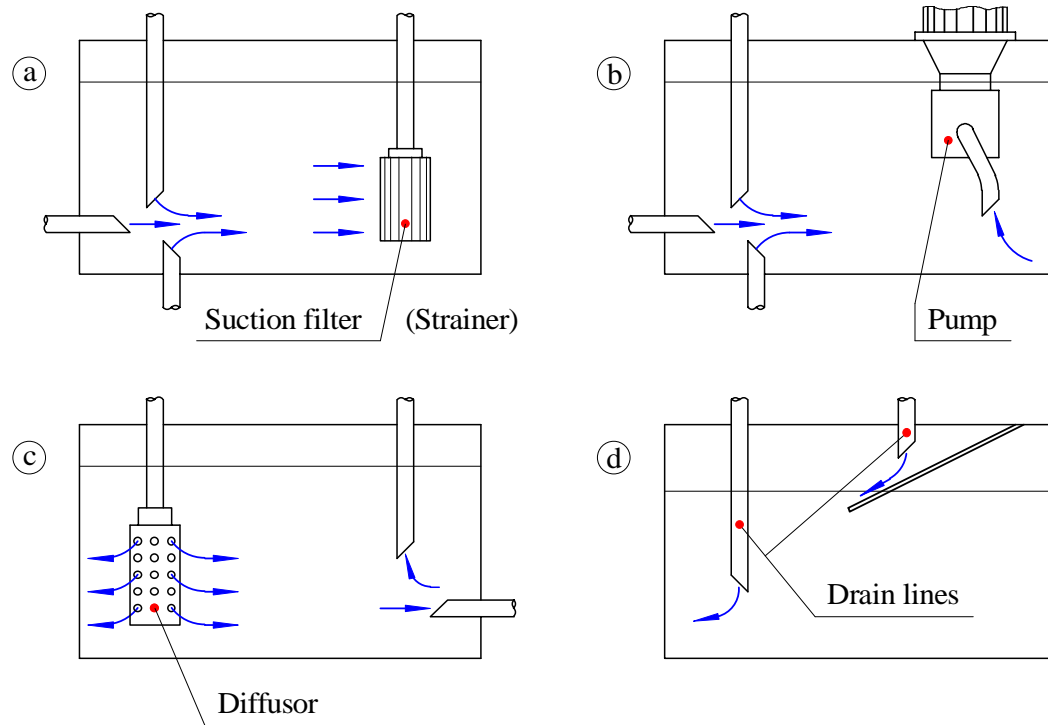

Positioning of pump in relation to reservoir

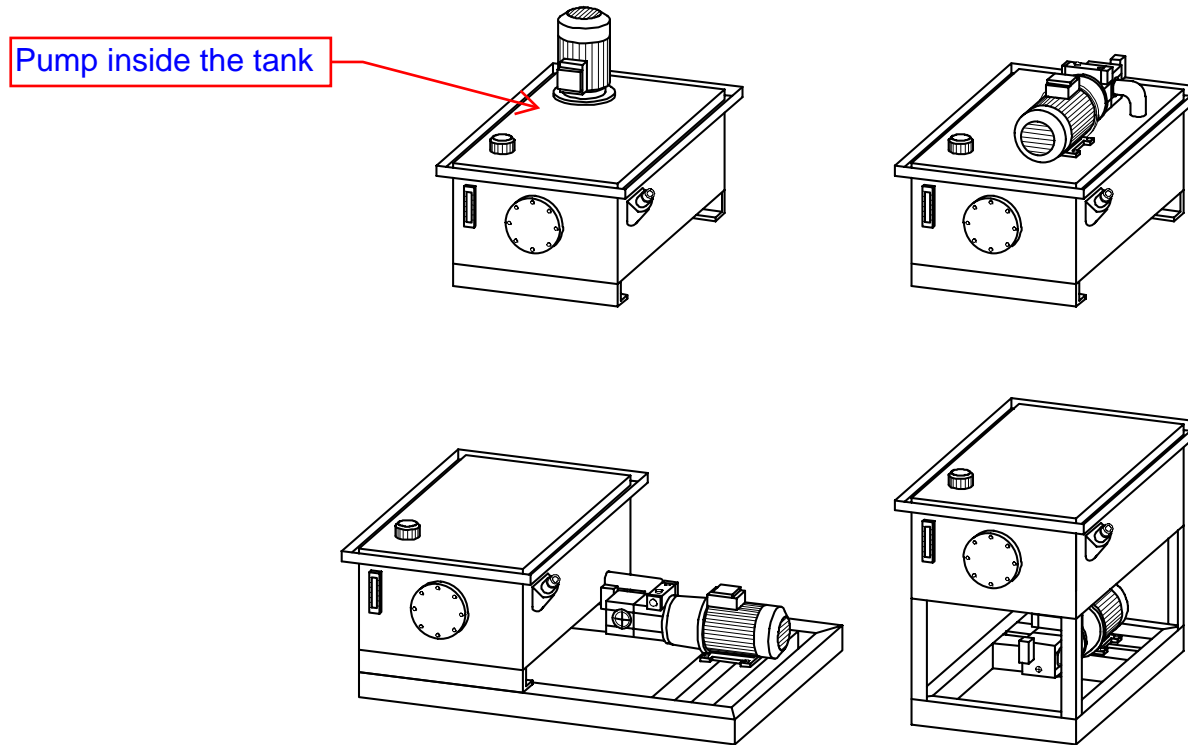

Piping components

Pipes
Hoses
Connections, fittings
Blocks

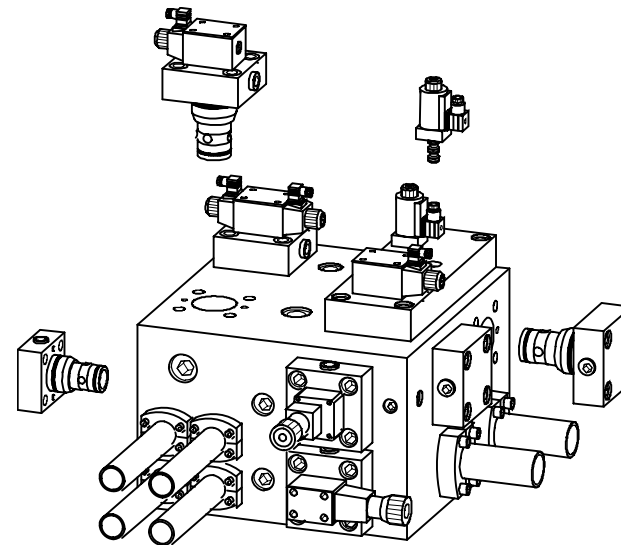
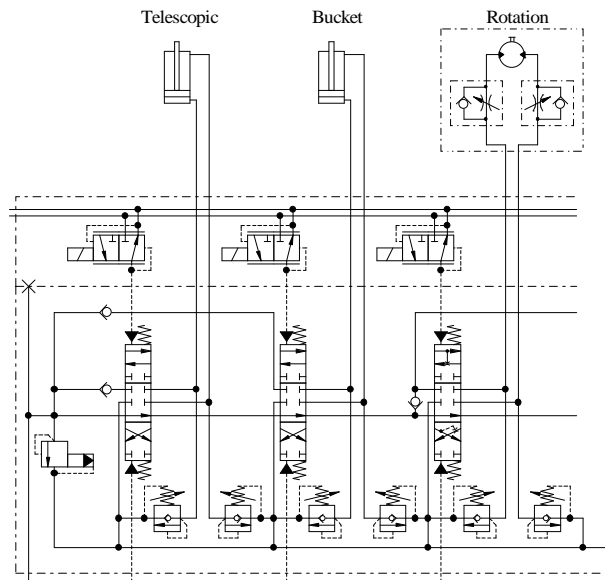
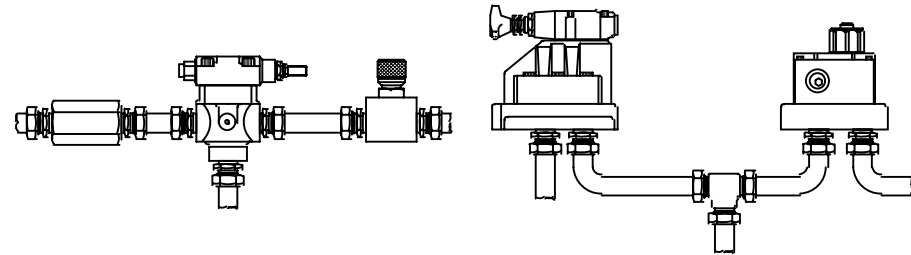

Pipes

Rigid connection

Type, material and wall thickness of pipe are affected by system pressure, flow rate, fluid type and the connector/fitting types.

Flow channel	Recommended flow velocity v [m/s]	Maximum flow velocity v_{max} [m/s]
Suction line	0,5- 1,0	1,0- 1,5
Return line	2,0- 3,0	3,0- 4,0
Pressure lines		
6,3- 10 MPa	4,0- 4,5	6,0
10- 16 MPa	4,5- 5,0	6,0
16- 25 MPa	5,0- 5,5	6,0
25- 40 MPa	5,5- 6,0	6,0

Pipe's outer diameter d [mm]	Pipe wall thickness [mm]				
	Nominal pressure [MPa]				
	6,3	10	16	25	40
6	1	1	1	1	1,5
8	1	1	1	1,5	1,5
10	1	1	1	1,5	2
12	1	1	1,5	2	2,5
16	1,5	1,5	1,5	2	3
20	1,5	1,5	2	2,5	4
25	2	2	3	3	5
30	2	2	3	4	6
38	3	3	4	5	7
50	3	3	6	6	9

Dimensioning principle:
System pressure losses should be ~ 3–10 % of the system pressure level.

Hoses

Flexible connection

Classification by the operational pressure level:

- low pressure hoses
- medium pressure hoses
- high pressure hoses
- ultra-high pressure hoses

Hoses increase the elasticity of the system !



Hoses

Most common standard SAE J517 (14 groups: SAE 100R1–14)

Size is expressed by a code number representing the inner diameter (with exceptions of SAE 100R5 and SAE 100R14, outer diameter)

The **code** number is based on **1/16 th division of inch**

Size can also be expressed in DIN standard nominal size (= hose's inner diameter's rough value in full millimetres)

SAE size code	Inner diameter of hose		Nominal size NS
	[in]	[mm]	
-04	1/4	6,4	6
-05	5/16	7,9	8
-06	3/8	9,5	10
-08	1/2	12,7	12
-10	5/8	15,9	16
-12	3/4	19,0	20
-16	1	25,4	25
-20	1 1/4	31,8	32
-24	1 1/2	38,1	40
-32	2	50,8	50

Connectors, Fittings

Connecting pipes and hoses to each other and components

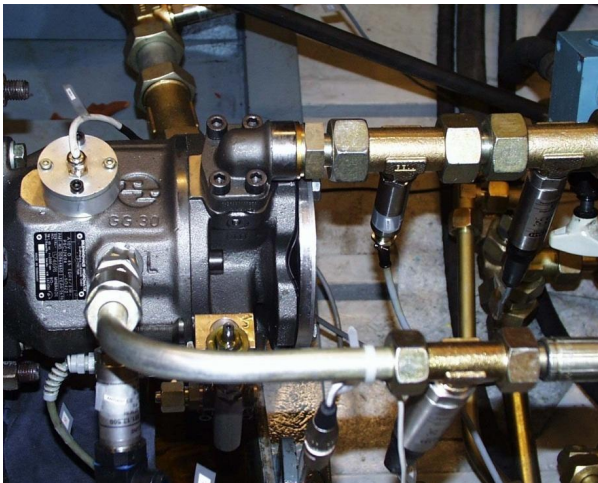

Low pressure connectors
High pressure connectors

Threaded connectors
(BSP, BSPT, M, NPTF, UNF, etc.)

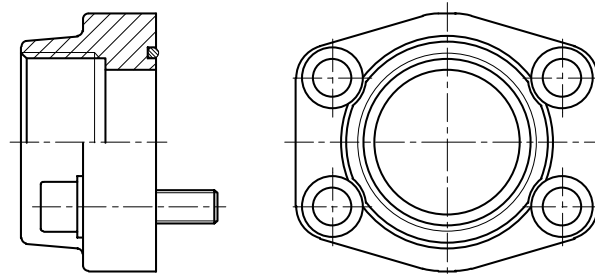
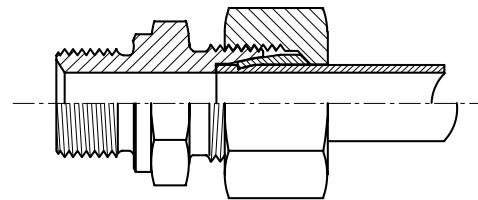

Flange
connectors
(SAE, DIN,
CETOP)

Connectors, Fittings

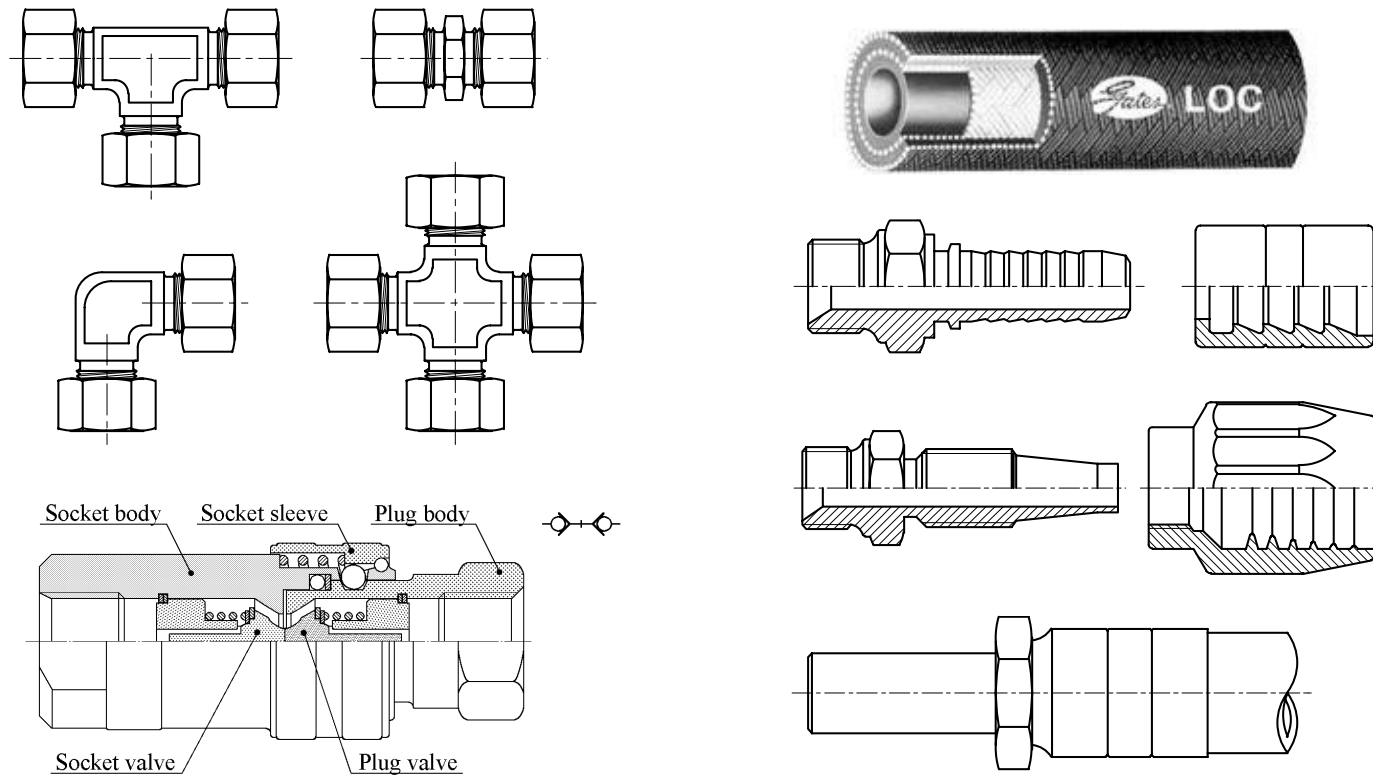

Connecting components to each other

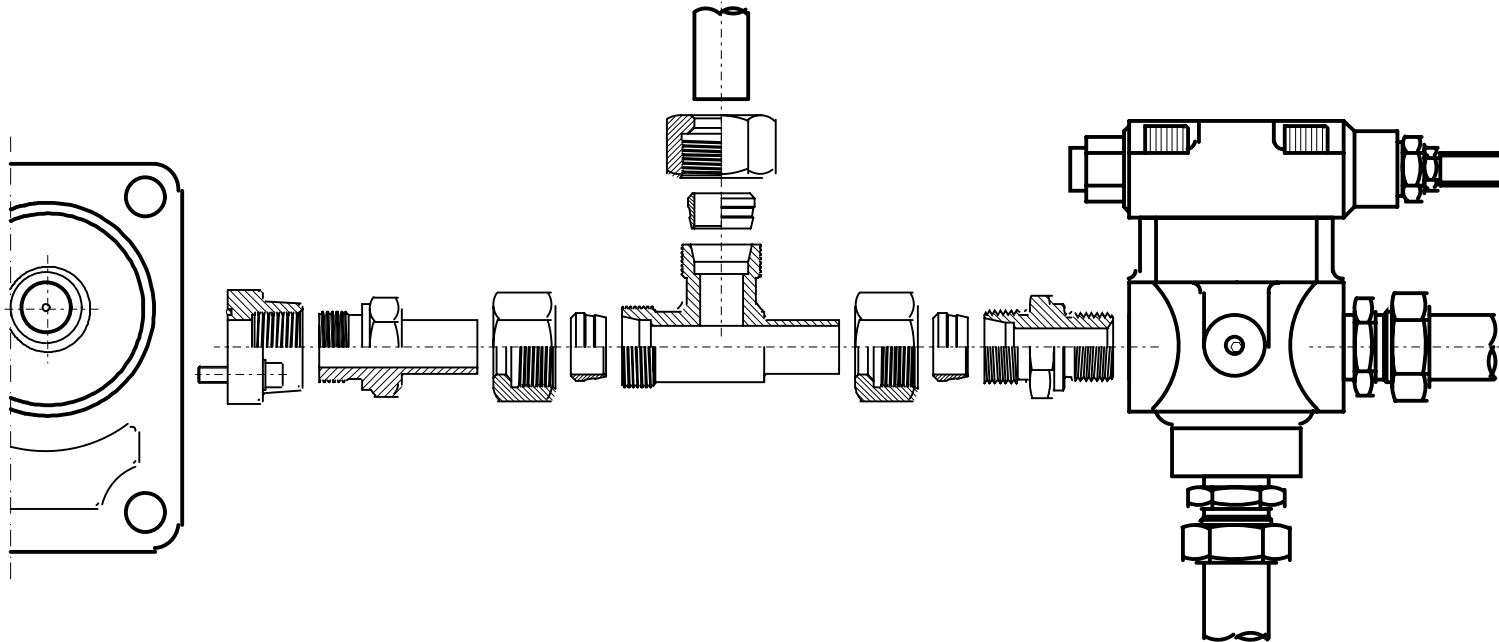

Example case: connecting components with piping components

Lecture themes - Recap

Impurities in system

- effect?
- removal?

Temperature in system

- what kind of effect does it have on the system?
- how can it be kept in check?

Reservoir, what can it do for the system?

Piping, how about it?