

MEC-E8001 Finite Element Analysis, week 5/2019

1. The spring force of non-linear spring depends on the dimensionless displacement $a = u/L$ according to $F = k(a - a^2 + a^3/3)$. Determine the dimensionless displacement $a = u/L$ if force $F = k/4$.

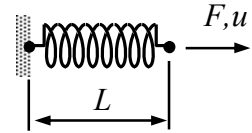

Answer $a = \frac{u}{L} \approx 0.370$

2. Determine the displacement at node 2 of the elastic bar shown by the large deformation theory. Take into account only the transverse displacement u_{Y2} ($u_{X2} = 0$). When $F = 0$, the cross-sectional area and length of the bar are A and L , respectively. Constitutive equation of the material is $S_{xx} = CE_{xx}$, in which C is constant. Use two elements with linear shape functions.

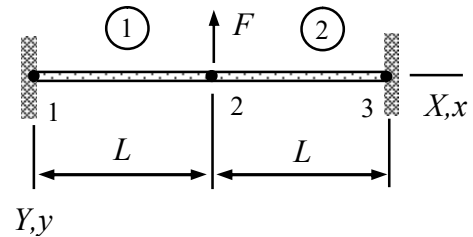

Answer $u_{Y2} = -\left(\frac{FL^3}{AC}\right)^{1/3}$

3. Consider the bar shown loaded by a point force. Determine the equilibrium equations in terms of the dimensionless displacement components $a_1 = u_{X2}/L$ and $a_2 = u_{Y2}/L$ according to the large displacement bar theory. Assume that displacement component $w = 0$ and use linear approximation to the non-zero components u and v . Without loading, the area of cross-section and the length of bar are A^0 and L^0 , respectively. Constitutive equation of the material is $S_{xx} = CE_{xx}$, in which C is constant.

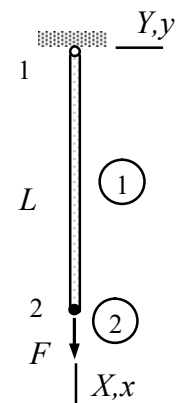

Answer $(1 + a_1)(a_1 + \frac{1}{2}a_1^2 + \frac{1}{2}a_2^2) - \frac{F}{A^0C} = 0$ and $a_2(2a_1 + a_1^2 + a_2^2) = 0$

4. Determine the equilibrium equation of the elastic bar of the figure with the large deformation theory. The active degree of freedom is u_{X2} and the cross-sectional area and length of the bar are A and L without the point force F acting on node 2. Constitutive equation of the material is $S_{xx} = CE_{xx}$, in which C is constant. Use two elements with linear shape functions.

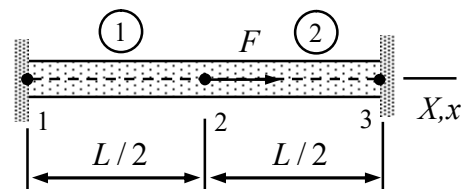

Answer $a(1 + 2a^2) - \frac{1}{4} \frac{F}{AC} = 0$ where $a = \frac{u_{X2}}{L}$

5. Consider the structure shown loaded by its own weight. Determine the equations giving the displacement u_{X2} of the free end according to large displacement bar theory. Without gravity, cross-sectional area, length, and density of the bar are A , L , and ρ , respectively. Constitutive equation of the material is $S_{xx} = CE_{xx}$, in which C is constant. Use a linear approximation.

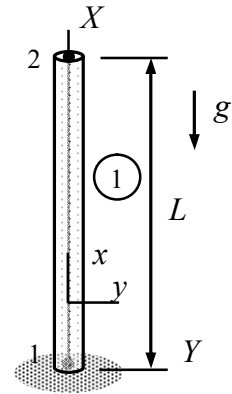

Answer $(1 + \frac{u_{X2}}{L}) \frac{u_{X2}}{L} (2 + \frac{u_{X2}}{L}) + \frac{L\rho g}{C} = 0$

6. Derive the equilibrium equation of the elastic truss shown with the large deformation theory. The cross-sectional areas and length of the bars are A and L when $F = 0$. Constitutive equation of the material is $S_{xx} = CE_{xx}$, in which C is constant. Assume a planar problem of two elements.

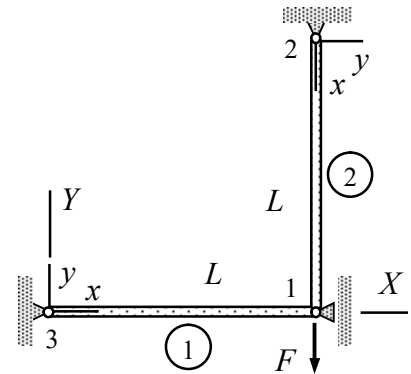

Answer $\frac{u_{Y1}}{L} \frac{CA}{2} [2(\frac{u_{Y1}}{L})^2 - 3\frac{u_{Y1}}{L} + 2] + F = 0$

7. A thin triangular slab (assume plane stress conditions) loaded by a horizontal force is allowed to move horizontally at node 1 and nodes 2 and 3 are fixed. Derive the equilibrium equation for the structure according to the large displacement theory. Material parameters C , ν and thickness t at the initial geometry of the slab are constants.

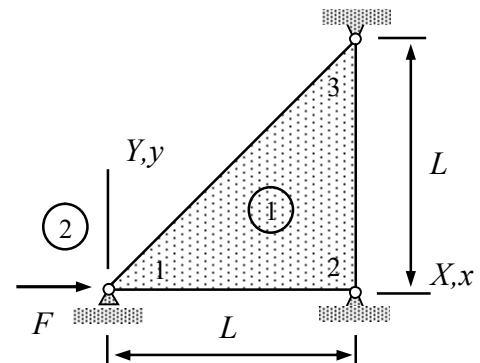

Answer $\frac{1}{2} \frac{tLC}{1-\nu^2} a(-1+a)(-1+\frac{1}{2}a) - F = 0$ where $a = \frac{u_{X1}}{L}$

8. A structure, consisting of a thin slab under the plane stress conditions and a bar, is loaded by a horizontal force F acting on node 1. Material properties are C and ν , thickness of the slab is t , and the cross-sectional area of the bar A at the initial unloaded geometry. Determine the equilibrium equation giving as its solution the displacement component u_{X1} of node 1 according to the large displacement theory.

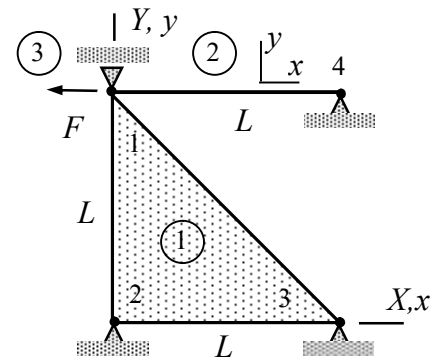

Answer $\frac{L}{4} \frac{tC}{1-\nu^2} a(a^2 + 1 - \nu) + CA(-1+a)a(-a + \frac{1}{2}a) + F = 0$ where $a = \frac{u_{X1}}{L}$

9. A long wall having triangular cross-section, and made of homogeneous, isotropic, linearly elastic material, is subjected to its own weight. Determine the equilibrium equation giving as its solution displacement components u_{Y3} according to the large displacement theory. Nodes 1 and 2 are fixed. Use a three-node element and assume plane stress conditions and symmetry $u_{X3} = 0$. Material properties C , ν and the density ρ of the initial geometry are constants.

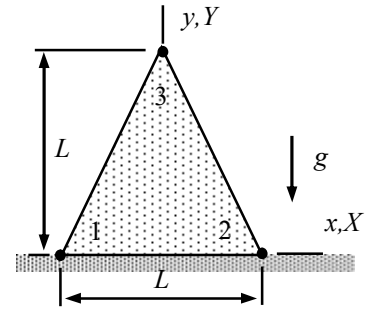

Answer $(1+a)a(1+\frac{1}{2}a)+\frac{1}{3}(1-\nu^2)\frac{L\rho g}{E}=0$ where $a=\frac{u_{Y3}}{L}$.

10. Node 4 of a thin rectangular slab, loaded by force F , is allowed to move horizontally and nodes 1, 2, and 3 are fixed. Assume plane stress conditions, and derive the equilibrium equation of the structure according to the large deformation theory. Use just one bilinear element. Material parameters C and $\nu = 0$. Thickness of the slab at the initial geometry is t .

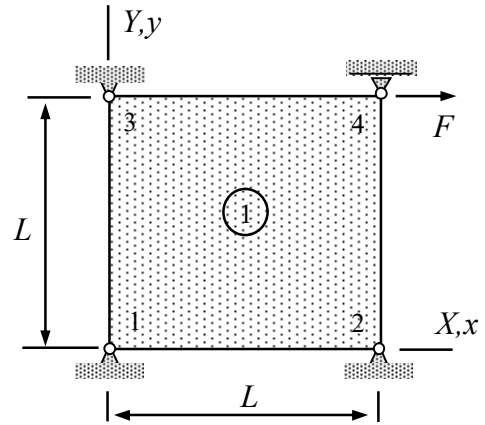

Answer $\frac{1}{2}a+\frac{5}{8}a^2+\frac{14}{45}a^3-\frac{F}{tLC}=0$ where $a=\frac{u_{X4}}{L}$.

The spring force of non-linear spring depends on the dimensionless displacement $a = u / L$ according to $F = k(a - a^2 + a^3/3)$. Determine the dimensionless displacement $a = u / L$ if force $F = k / 4$.

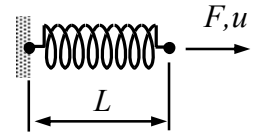

Solution

As the equilibrium equation is non-linear, finding the displacement as function of the force by hand calculations is difficult (but possible for a third order polynomial). Mathematica gives three mathematically correct solution

$$\left\{ \left\{ a \rightarrow 1 - \frac{1}{2^{2/3}} \right\}, \left\{ a \rightarrow 1 + \frac{1 - \mathbf{i} \sqrt{3}}{2 \times 2^{2/3}} \right\}, \left\{ a \rightarrow 1 + \frac{1 + \mathbf{i} \sqrt{3}}{2 \times 2^{2/3}} \right\} \right\}$$

of which the real valued is obviously the physically correct one. A simple graphical method for finding one solution to

$$R(a) = F - k(a - a^2 + \frac{1}{3}a^3)$$

in a given range $a \in [a_{\min}, a_{\max}]$ uses an iterative refinement of the range so that the sign change of $R(a)$ is bracketed inside a smaller and smaller range.

Determine the displacement at node 2 of the elastic bar shown by the large deformation theory. Take into account only the transverse displacement u_{Y2} ($u_{X2} = 0$). When $F = 0$, the cross-sectional area and length of the bar are A and L , respectively. Constitutive equation of the material is $S_{xx} = CE_{xx}$, in which C is constant. Use two elements with linear shape functions.

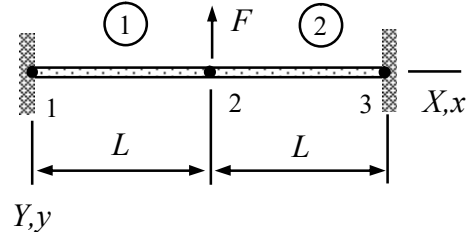

Solution

Virtual work density of the non-linear bar model

$$\delta w_{\Omega^{\circ}}^{\text{int}} = -\left(\frac{d\delta u}{dx} + \frac{du}{dx} \frac{d\delta u}{dx} + \frac{dv}{dx} \frac{d\delta v}{dx} + \frac{dw}{dx} \frac{d\delta w}{dx}\right) CA^{\circ} \left[\frac{du}{dx} + \frac{1}{2} \left(\frac{du}{dx}\right)^2 + \frac{1}{2} \left(\frac{dv}{dx}\right)^2 + \frac{1}{2} \left(\frac{dw}{dx}\right)^2\right]$$

is based on the Green-Lagrange strain definition which is physically correct also when rotations/displacements are large. The expression depends on all displacement components, material property is denoted by C (constitutive equation $S_{xx} = CE_{xx}$), and the superscript in the cross-sectional area A° (and in other quantities) refers to the initial geometry (strain and stress vanishes). Otherwise, equilibrium equations follow in the same manner as in the linear case.

For element 1, the non-zero displacement components is $u_{y2} = u_{Y2}$. As the initial length of the element $h^{\circ} = L$, linear approximations to the displacement components

$$u = w = 0 \text{ and } v = \frac{x}{L} u_{Y2} \Rightarrow \frac{du}{dx} = \frac{dw}{dx} = 0 \text{ and } \frac{dv}{dx} = \frac{u_{Y2}}{L}.$$

When the approximation is substituted there, virtual work density of the internal forces and thereby the virtual work expression (density is constant) simplify to

$$\delta w_{\Omega^{\circ}}^{\text{int}} = -\frac{\delta u_{Y2}}{L} \frac{u_{Y2}}{L} \frac{CA}{2} \left(\frac{u_{Y2}}{L}\right)^2 \Rightarrow \delta W^1 = -\delta u_{Y2} \frac{CA}{2} \left(\frac{u_{Y2}}{L}\right)^3.$$

For element 2, the non-zero displacement component $u_{y2} = u_{Y2}$. As the initial length of the element $h^{\circ} = L$, linear approximations to the displacement components

$$u = w = 0 \text{ and } v = \left(1 - \frac{x}{L}\right) u_{Y2} \Rightarrow \frac{du}{dx} = \frac{dw}{dx} = 0 \text{ and } \frac{dv}{dx} = -\frac{u_{Y2}}{L}.$$

When the approximation is substituted there, virtual work density of the internal forces and thereby the virtual work expression (density is constant) simplifies to

$$\delta w_{\Omega^{\circ}}^{\text{int}} = -\frac{\delta u_{Y2}}{L} \frac{u_{Y2}}{L} \frac{CA}{2} \left(\frac{u_{Y2}}{L}\right)^2 \Rightarrow \delta W^2 = -\delta u_{Y2} \frac{CA}{2} \left(\frac{u_{Y2}}{L}\right)^3.$$

Virtual work expression of the point force is

$$\delta W^3 = -F \delta u_{Y2}.$$

Virtual work expression of the structure is obtained as the sum of the element contributions

$$\delta W = -\delta u_{Y2} \left[\frac{CA}{2} \left(\frac{u_{Y2}}{L} \right)^3 + \frac{CA}{2} \left(\frac{u_{Y2}}{L} \right)^3 + F \right].$$

Principle of virtual work and the fundamental lemma of variation calculus imply that

$$\left(\frac{u_{Y2}}{L} \right)^3 + \frac{F}{CA} = 0 \quad \Rightarrow \quad u_{Y2} = - \left(\frac{FL^3}{CA} \right)^{1/3}. \quad \leftarrow$$

Consider the bar shown loaded by a point force. Determine the equilibrium equations in terms of the dimensionless displacement components $a_1 = u_{X2} / L$ and $a_2 = u_{Y2} / L$ according to the large displacement bar theory. Assume that displacement component $w = 0$ and use linear approximation to the non-zero components u and v . Without loading, the area of cross-section and the length of bar are A° and L° , respectively. Constitutive equation of the material is $S_{xx} = CE_{xx}$, in which C is constant.

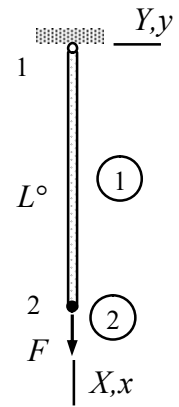

Solution

Virtual work density of internal forces is

$$\delta w_{\Omega^\circ}^{\text{int}} = -\left(\frac{d\delta u}{dx} + \frac{du}{dx} \frac{d\delta u}{dx} + \frac{dv}{dx} \frac{d\delta v}{dx} + \frac{dw}{dx} \frac{d\delta w}{dx}\right) CA^\circ \left[\frac{du}{dx} + \frac{1}{2} \left(\frac{du}{dx}\right)^2 + \frac{1}{2} \left(\frac{dv}{dx}\right)^2 + \frac{1}{2} \left(\frac{dw}{dx}\right)^2\right].$$

Assuming a linear approximation to displacement components with $u_{x2} = u_{X2}$ and $u_{y2} = u_{Y2}$

$$u = \frac{x}{L^\circ} u_{X2}, \quad v = \frac{x}{L^\circ} u_{Y2}, \quad \text{and} \quad w = 0 \quad \Rightarrow \quad \frac{du}{dx} = \frac{u_{X2}}{L^\circ}, \quad \frac{dv}{dx} = \frac{u_{Y2}}{L^\circ}, \quad \text{and} \quad \frac{dw}{dx} = 0.$$

Virtual work expression is obtained as integral of the density over the domain occupied by the body (notice that the virtual work density is constant when the approximations are substituted there):

$$\delta W^1 = -\left(\frac{\delta u_{X2}}{L^\circ} + \frac{u_{X2}}{L^\circ} \frac{\delta u_{X2}}{L^\circ} + \frac{u_{Y2}}{L^\circ} \frac{\delta u_{Y2}}{L^\circ}\right) L^\circ CA^\circ \left[\frac{u_{X2}}{L^\circ} + \frac{1}{2} \left(\frac{u_{X2}}{L^\circ}\right)^2 + \frac{1}{2} \left(\frac{u_{Y2}}{L^\circ}\right)^2\right],$$

$$\delta W^2 = F \delta u_{X2}.$$

Virtual work expression of the structure is $\delta W = \delta W^1 + \delta W^2$. In terms of dimensionless displacements $a_1 = u_{X2} / L^\circ$ and $a_2 = u_{Y2} / L^\circ$ (introduced just to simplify the expressions)

$$\delta W = -(\delta a_1 + a_1 \delta a_1 + a_2 \delta a_2) L^\circ CA^\circ \left(a_1 + \frac{1}{2} a_1^2 + \frac{1}{2} a_2^2\right) + FL^\circ \delta a_1 \quad \Leftrightarrow$$

$$\delta W = -CA^\circ \begin{Bmatrix} \delta a_1 \\ \delta a_2 \end{Bmatrix}^T \begin{Bmatrix} (1 + a_1) \left(a_1 + \frac{1}{2} a_1^2 + \frac{1}{2} a_2^2\right) - \frac{F}{CA^\circ} \\ a_2 \left(a_1 + \frac{1}{2} a_1^2 + \frac{1}{2} a_2^2\right) \end{Bmatrix}.$$

principle of virtual work and the fundamental lemma of variation calculus imply that

$$(1 + a_1) \left(a_1 + \frac{1}{2} a_1^2 + \frac{1}{2} a_2^2\right) - \frac{F}{CA^\circ} = 0 \quad \text{and} \quad a_2 \left(a_1 + \frac{1}{2} a_1^2 + \frac{1}{2} a_2^2\right) = 0. \quad \leftarrow$$

In this case, the solution can be deduced without numerical calculations: the latter equation implies that $a_2 = 0$ as the other option $a_1 + a_1^2 / 2 + a_2^2 / 2 = 0$ would mean an inconsistency with the first equation. Knowing this (the real valued solution)

$$a_1 = \frac{1}{3} \left(-3 - \frac{3^{2/3}}{\alpha} - 3^{1/3} \alpha \right) \text{ where } \alpha = \left(-9f + \sqrt{-3 + 81f^2} \right)^{1/3} \text{ and } f = \frac{F}{CA^\circ} .$$

Derive the equilibrium equation of the elastic bar of the figure with the large deformation theory. The non-zero displacement component is u_{X2} and the cross-sectional area and length of the bar are A and L , when the point force F acting on node 2 is zero. Constitutive equation of the material is $S = CE$, in which C is constant. Use two elements with linear shape functions.

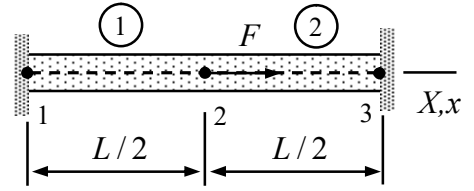

Solution

Virtual work density of the non-linear bar model

$$\delta w_{\Omega^0}^{\text{int}} = -\left(\frac{d\delta u}{dx} + \frac{du}{dx} \frac{d\delta u}{dx} + \frac{dv}{dx} \frac{d\delta v}{dx} + \frac{dw}{dx} \frac{d\delta w}{dx}\right) CA^0 \left[\frac{du}{dx} + \frac{1}{2} \left(\frac{du}{dx}\right)^2 + \frac{1}{2} \left(\frac{dv}{dx}\right)^2 + \frac{1}{2} \left(\frac{dw}{dx}\right)^2 \right]$$

is based on the Green-Lagrange strain definition which works also when rotations/displacements are large. The expression depends on all displacement components, material property is denoted by C (constitutive equation $S_{xx} = CE_{xx}$), and the superscript in the cross-sectional area A^0 (and in other quantities) refers to the initial geometry (strain and stress vanishes). Otherwise, equilibrium equations follow in the same manner as in the linear case.

For element 1, $u_{x2} = u_{X2}$. As the initial length of the element $h^0 = L/2$, linear approximations to the displacement components

$$v = w = 0 \text{ and } u = 2 \frac{x}{L} u_{X2} \Rightarrow \frac{du}{dx} = 2 \frac{u_{X2}}{L}.$$

When the approximation is substituted there, virtual work density of the internal forces and thereby the virtual work expression (density is constant) simplify to

$$\delta w_{\Omega^0}^{\text{int}} = -2 \frac{\delta u_{X2}}{L} \left(1 + 2 \frac{u_{X2}}{L}\right) CA^0 2 \frac{u_{X2}}{L} \left(1 + \frac{1}{2} 2 \frac{u_{X2}}{L}\right) \Rightarrow$$

$$\delta W^1 = -\delta u_{X2} \left(1 + 2 \frac{u_{X2}}{L}\right) 2CA^0 \frac{u_{X2}}{L} \left(1 + \frac{u_{X2}}{L}\right).$$

For element 2, $u_{x2} = u_{X2}$. As the initial length of the element $h^0 = L/2$, linear approximations to the displacement components

$$v = w = 0 \text{ and } u = \left(1 - 2 \frac{x}{L}\right) u_{X2} \Rightarrow \frac{du}{dx} = -2 \frac{u_{X2}}{L}.$$

When the approximation is substituted there, virtual work density of the internal forces and thereby the virtual work expression (density is constant) simplify to

$$\delta w_{\Omega^0}^{\text{int}} = -2 \left(-\frac{\delta u_{X2}}{L}\right) \left(1 - 2 \frac{u_{X2}}{L}\right) 2CA^0 \left(-\frac{u_{X2}}{L}\right) \left(1 - \frac{u_{X2}}{L}\right) \Rightarrow$$

$$\delta W^2 = -\delta u_{X2} \left(1 - 2 \frac{u_{X2}}{L}\right) 2CA \frac{u_{X2}}{L} \left(1 - \frac{u_{X2}}{L}\right).$$

Virtual work expression of the force is

$$\delta W^3 = F \delta u_{X2}.$$

Virtual work expression of the structure is obtained as sum over the element contributions

$$\delta W = -\delta u_{X2} \left[\left(1 + 2 \frac{u_{X2}}{L}\right) 2CA \frac{u_{X2}}{L} \left(1 + \frac{u_{X2}}{L}\right) + \left(1 - 2 \frac{u_{X2}}{L}\right) 2CA \frac{u_{X2}}{L} \left(1 - \frac{u_{X2}}{L}\right) - F \right].$$

Principle of virtual work and the fundamental lemma of variation calculus imply that

$$\frac{u_{X2}}{L} \left[\left(1 + 2 \frac{u_{X2}}{L}\right) \left(1 + \frac{u_{X2}}{L}\right) + \left(1 - 2 \frac{u_{X2}}{L}\right) \left(1 - \frac{u_{X2}}{L}\right) \right] - \frac{F}{2CA} = 0 \Rightarrow$$

$$a(1 + 2a^2) - \frac{F}{4CA} = 0 \quad \text{in which } a = \frac{u_{X2}}{L}. \quad \leftarrow$$

Consider the structure shown loaded by its own weight. Determine the equations giving the displacement u_{X2} of the free end according to large displacement bar theory. Without gravity, cross-sectional area, length, and density of the bar are A , L , and ρ , respectively. Constitutive equation of the material is $S_{xx} = CE_{xx}$, in which C is constant. Use a linear approximation.

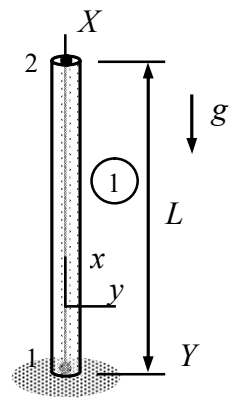

Solution

As $v = w = 0$, virtual work densities of internal and external distributed forces of the non-linear bar model simplify to

$$\delta w_{\Omega^{\circ}}^{\text{int}} = -\left(\frac{d\delta u}{dx} + \frac{du}{dx} \frac{d\delta u}{dx}\right) CA^{\circ} \left[\frac{du}{dx} + \frac{1}{2} \left(\frac{du}{dx}\right)^2\right] \quad \text{and} \quad \delta w_{\Omega^{\circ}}^{\text{ext}} = -\delta u \rho g A$$

the negative sign of the external part takes into account the direction of gravity with respect to the x -axis. The non-zero displacement component of the structure is the vertical displacement of node 2 i.e. $u_{x2} = u_{X2}$. Linear approximation (two-node element) is

$$u = \frac{x}{L} u_{X2} \Rightarrow \frac{du}{dx} = \frac{u_{X2}}{L}.$$

When the approximation is substituted there, virtual work densities simplify to

$$\delta w_{\Omega^{\circ}}^{\text{int}} = -\left(\frac{\delta u_{X2}}{L}\right) \left(1 + \frac{u_{X2}}{L}\right) \frac{CA}{2} \left(\frac{u_{X2}}{L}\right) \left(2 + \frac{u_{X2}}{L}\right) \quad \text{and} \quad \delta w_{\Omega^{\circ}}^{\text{ext}} = -\frac{x}{L} \delta u_{X2} \rho g A.$$

Virtual work expression is integral of the virtual work density over the domain occupied by the element at the initial geometry:

$$\delta W^{\text{int}} = \int_0^L \delta w_{\Omega^{\circ}}^{\text{int}} dx = -\delta u_{X2} \left(1 + \frac{u_{X2}}{L}\right) \frac{CA}{2} \left(\frac{u_{X2}}{L}\right) \left(2 + \frac{u_{X2}}{L}\right),$$

$$\delta W^{\text{ext}} = \int_0^L \delta w_{\Omega^{\circ}}^{\text{ext}} dx = -\frac{1}{2} L \delta u_{X2} \rho g A.$$

Principle of virtual work with $\delta W = \delta W^{\text{int}} + \delta W^{\text{ext}}$ and the fundamental lemma of variation calculus imply that

$$\left(1 + \frac{u_{X2}}{L}\right) \frac{CA}{2} \left(\frac{u_{X2}}{L}\right) \left(2 + \frac{u_{X2}}{L}\right) + \frac{1}{2} L \rho g A = 0 \Rightarrow (1+a)a(2+a) + \frac{L\rho g}{C} = 0, \quad a = \frac{u_{X2}}{L}. \quad \leftarrow$$

Derive the equilibrium equation of the elastic truss shown with the large deformation theory. The cross-sectional areas and length of the bars are A and L when $F = 0$. Constitutive equation of the material is $S_{xx} = CE_{xx}$, in which C is constant. Assume a planar problem of two elements.

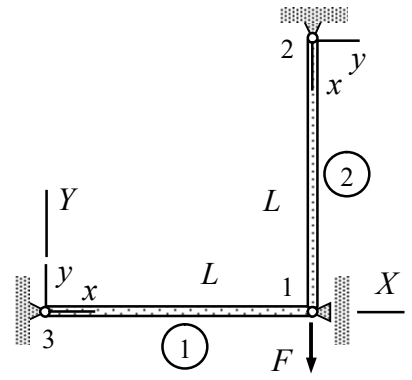

Solution

As $w = 0$ and cross-sectional area of the initial geometry is A , virtual work density of internal forces of the large displacement bar model simplifies to

$$\delta w_{\Omega^{\circ}}^{\text{int}} = -\left(\frac{d\delta u}{dx} + \frac{du}{dx} \frac{d\delta u}{dx} + \frac{dv}{dx} \frac{d\delta v}{dx}\right) CA \left[\frac{du}{dx} + \frac{1}{2} \left(\frac{du}{dx}\right)^2 + \frac{1}{2} \left(\frac{dv}{dx}\right)^2\right].$$

In element 1, linear approximations to the displacement components expressed in terms of u_{Y1} are

$$u = 0 \text{ and } v = \frac{x}{L} u_{Y1} \Rightarrow \frac{du}{dx} = 0 \text{ and } \frac{dv}{dx} = \frac{u_{Y1}}{L}.$$

When the approximation is substituted there, virtual work density of internal forces and the virtual work expression take the forms

$$\delta w_{\Omega^{\circ}}^{\text{int}} = -\frac{u_{Y1}}{L} \frac{\delta u_{Y1}}{L} CA \frac{1}{2} \left(\frac{u_{Y1}}{L}\right)^2,$$

$$\delta W^1 = \int_0^L \delta w_{\Omega^{\circ}}^{\text{int}} dx = -\delta u_{Y1} CA \frac{1}{2} \left(\frac{u_{Y1}}{L}\right)^3.$$

In element 2, linear approximations to the displacement components expressed in terms of u_{Y1} are

$$u = -\frac{x}{L} u_{Y1} \text{ and } v = 0 \Rightarrow \frac{du}{dx} = -\frac{u_{Y1}}{L} \text{ and } \frac{dv}{dx} = 0.$$

When the approximation is substituted there, virtual work density of internal forces and thereby the virtual work expression take the forms

$$\delta w_{\Omega^{\circ}}^{\text{int}} = -\left(\frac{\delta u_{Y1}}{L}\right) \left(1 - \frac{u_{Y1}}{L}\right) CA \left(\frac{u_{Y1}}{L}\right) \left(1 - \frac{1}{2} \frac{u_{Y1}}{L}\right),$$

$$\delta W^2 = \int_0^L \delta w_{\Omega^{\circ}}^{\text{int}} dx = -\delta u_{Y1} \left(1 - \frac{u_{Y1}}{L}\right) CA \left(\frac{u_{Y1}}{L}\right) \left(1 - \frac{1}{2} \frac{u_{Y1}}{L}\right).$$

Element 3 contribution (point force)

$$\delta W^3 = -F \delta u_{Y1}.$$

Virtual work expression of the structure is sum over the element contributions. In the standard form

$$\delta W = -\delta u_{Y1} \left[\frac{u_{Y1}}{L} CA \frac{1}{2} \left(\frac{u_{Y1}}{L} \right)^2 + \left(1 - \frac{u_{Y1}}{L} \right) CA \left(\frac{u_{Y1}}{L} \right) \left(1 - \frac{1}{2} \frac{u_{Y1}}{L} \right) + F \right].$$

Principle of virtual work and the fundamental lemma of variation calculus imply the equilibrium equation

$$\frac{u_{Y1}}{L} \frac{CA}{2} \left[2 \left(\frac{u_{Y1}}{L} \right)^2 - 3 \frac{u_{Y1}}{L} + 2 \right] + F = 0. \quad \leftarrow$$

A thin triangular slab (assume plane stress conditions) loaded by a horizontal force is allowed to move horizontally at node 1 and nodes 2 and 3 are fixed. Derive the equilibrium equation for the structure according to the large displacement theory. Material parameters C , ν and thickness t at the initial geometry of the slab are constants.

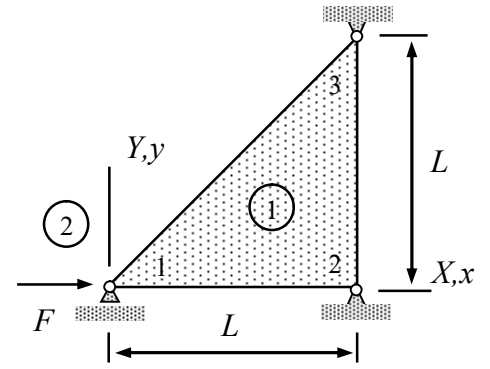

Solution

Virtual work density of internal force, when modified for large displacement analysis with the same constitutive equation as in the linear case of plane stress, is given by

$$\delta w_{\Omega^e}^{\text{int}} = - \begin{Bmatrix} \delta E_{xx} \\ \delta E_{yy} \\ 2\delta E_{xy} \end{Bmatrix}^T \frac{tC}{1-\nu^2} \begin{bmatrix} 1 & \nu & 0 \\ \nu & 1 & 0 \\ 0 & 0 & (1-\nu)/2 \end{bmatrix} \begin{Bmatrix} E_{xx} \\ E_{yy} \\ 2E_{xy} \end{Bmatrix}, \begin{Bmatrix} E_{xx} \\ E_{yy} \\ 2E_{xy} \end{Bmatrix} = \begin{Bmatrix} \frac{\partial u}{\partial x} + \frac{1}{2} \left(\frac{\partial u}{\partial x} \right)^2 + \frac{1}{2} \left(\frac{\partial v}{\partial x} \right)^2 \\ \frac{\partial v}{\partial y} + \frac{1}{2} \left(\frac{\partial u}{\partial y} \right)^2 + \frac{1}{2} \left(\frac{\partial v}{\partial y} \right)^2 \\ \frac{\partial u}{\partial y} + \frac{\partial v}{\partial x} + \frac{\partial u}{\partial x} \frac{\partial u}{\partial y} + \frac{\partial v}{\partial x} \frac{\partial v}{\partial y} \end{Bmatrix}.$$

Let us start with the approximations and the corresponding components of the Green-Lagrange strain. Linear shape functions can be deduced from the figure. Only the shape function $N_1 = (1 - x/L)$ of node 1 is needed. Displacement components $v = w = 0$ and

$$u = (1 - \frac{x}{L})u_{X1} \Rightarrow \frac{\partial u}{\partial x} = -\frac{u_{X1}}{L}, \quad \frac{\partial u}{\partial y} = 0, \quad E_{yy} = E_{xy} = 0 \quad \text{and} \quad E_{xx} = -\frac{u_{X1}}{L} + \frac{1}{2} \left(-\frac{u_{X1}}{L} \right)^2.$$

When the strain component expression are substituted there, virtual work density simplifies to

$$\delta w_{\Omega^e}^{\text{int}} = -\delta E_{xx} \frac{tC}{1-\nu^2} E_{xx} = -\frac{\delta u_{X1}}{L} \left(-1 + \frac{u_{X1}}{L} \right) \frac{tC}{1-\nu^2} \frac{u_{X1}}{L} \left(-1 + \frac{1}{2} \frac{u_{X1}}{L} \right).$$

Integration over the (initial) domain gives the virtual work expression. As the integrand is constant

$$\delta W^1 = -\frac{L^2}{2} \frac{\delta u_{X1}}{L} \left(-1 + \frac{u_{X1}}{L} \right) \frac{tC}{1-\nu^2} \frac{u_{X1}}{L} \left(-1 + \frac{1}{2} \frac{u_{X1}}{L} \right)$$

Virtual work expression of the point force follows from the definition of work

$$\delta W^2 = \delta u_{X1} F = \frac{\delta u_{X1}}{L} L F.$$

Virtual work expression of the structure is obtained as sum over the element contributions. In terms of the dimensionless displacement $a = u_{X1}/L$

$$\delta W = -\frac{L^2}{2} \delta a (-1+a) \frac{tC}{1-\nu^2} a \left(-1 + \frac{1}{2} a \right) + \delta a L F \Rightarrow \frac{L}{2} (-1+a) \frac{tC}{1-\nu^2} \left(-a + \frac{1}{2} a^2 \right) - F = 0. \quad \leftarrow$$

A structure, consisting of a thin slab under the plane stress conditions and a bar, is loaded by a horizontal force F acting on node 1. Material properties are C and ν , thickness of the slab is t , and the cross-sectional area of the bar A at the initial unloaded geometry. Determine the equilibrium equation giving as its solution the displacement component u_{X1} of node 1 according to the large displacement theory.

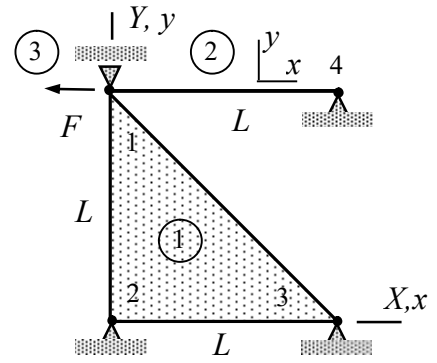

Solution

Virtual work densities of the thin slab and bar models, when modified for large displacement analysis with the same constitutive equation as in the linear case, are given by

$$\delta w_{\Omega^e}^{\text{int}} = - \begin{Bmatrix} \delta E_{xx} \\ \delta E_{yy} \\ 2\delta E_{xy} \end{Bmatrix}^T \frac{tC}{1-\nu^2} \begin{bmatrix} 1 & \nu & 0 \\ \nu & 1 & 0 \\ 0 & 0 & (1-\nu)/2 \end{bmatrix} \begin{Bmatrix} E_{xx} \\ E_{yy} \\ 2E_{xy} \end{Bmatrix}, \quad \begin{Bmatrix} E_{xx} \\ E_{yy} \\ 2E_{xy} \end{Bmatrix} = \begin{Bmatrix} \frac{\partial u}{\partial x} + \frac{1}{2} \left(\frac{\partial u}{\partial x} \right)^2 + \frac{1}{2} \left(\frac{\partial v}{\partial x} \right)^2 \\ \frac{\partial v}{\partial y} + \frac{1}{2} \left(\frac{\partial u}{\partial y} \right)^2 + \frac{1}{2} \left(\frac{\partial v}{\partial y} \right)^2 \\ \frac{\partial u}{\partial y} + \frac{\partial v}{\partial x} + \frac{\partial u}{\partial x} \frac{\partial u}{\partial y} + \frac{\partial v}{\partial x} \frac{\partial v}{\partial y} \end{Bmatrix},$$

$$\delta w_{\Omega^e}^{\text{int}} = -\delta E_{xx} CA^\circ E_{xx}, \quad E_{xx} = \frac{du}{dx} + \frac{1}{2} \left(\frac{du}{dx} \right)^2 + \frac{1}{2} \left(\frac{dv}{dx} \right)^2 + \frac{1}{2} \left(\frac{dw}{dx} \right)^2.$$

Element contributions need to be derived from approximations and virtual work densities. Approximations to the displacement components depend only on the shape function associated with node 1 as the other nodes are fixed (displacement vanishes).

Let us start with the thin slab element. In terms of the displacement component u_{X1}

$$u = \frac{y}{L} u_{X1} \quad \text{and} \quad v = 0 \quad \Rightarrow \quad \frac{\partial u}{\partial x} = 0, \quad \frac{\partial u}{\partial y} = \frac{u_{X1}}{L}, \quad \text{and} \quad \frac{\partial v}{\partial x} = \frac{\partial v}{\partial y} = 0,$$

giving

$$\begin{Bmatrix} E_{xx} \\ E_{yy} \\ 2E_{xy} \end{Bmatrix} = \frac{1}{2} \mathbf{a} \begin{Bmatrix} 0 \\ \mathbf{a} \\ 2 \end{Bmatrix} \quad \text{and} \quad \begin{Bmatrix} \delta E_{xx} \\ \delta E_{yy} \\ 2\delta E_{xy} \end{Bmatrix} = \delta \mathbf{a} \begin{Bmatrix} 0 \\ \mathbf{a} \\ 1 \end{Bmatrix} \quad \text{where} \quad \mathbf{a} = \frac{u_{X1}}{L} \quad \text{and} \quad \delta \mathbf{a} = \frac{\delta u_{X1}}{L}.$$

Virtual work density of the internal forces simplifies to (when the approximations are substituted there)

$$\delta w_{\Omega^e}^{\text{int}} = - \frac{tC}{1-\nu^2} \delta \mathbf{a} \begin{Bmatrix} 0 \\ \mathbf{a} \\ 1 \end{Bmatrix}^T \begin{bmatrix} 1 & \nu & 0 \\ \nu & 1 & 0 \\ 0 & 0 & (1-\nu)/2 \end{bmatrix} \frac{1}{2} \mathbf{a} \begin{Bmatrix} 0 \\ \mathbf{a} \\ 2 \end{Bmatrix} = -\delta \mathbf{a} \frac{1}{2} \mathbf{a} \frac{tC}{1-\nu^2} (\mathbf{a}^2 + 1 - \nu).$$

Virtual work expression is the integral of density over the domain occupied by the element (note that the virtual work density is constant in this case). Therefore

$$\delta W^1 = \delta w_{\Omega^{\circ}}^{\text{int}} \frac{L^2}{2} = -\delta a \frac{1}{2} a \frac{L^2}{2} \frac{tC}{1-\nu^2} (a^2 + 1 - \nu).$$

The linear approximations to the displacement of the bar element are $w = v = 0$ and

$$u = \left(1 - \frac{x}{L}\right) u_{X1} \Rightarrow \frac{du}{dx} = -\frac{u_{X1}}{L} = -a, \text{ and } E_{xx} = -\frac{u_{X1}}{L} + \frac{1}{2} \left(-\frac{u_{X1}}{L}\right)^2 = -a + \frac{1}{2} a^2.$$

For the bar element, virtual work density of the internal forces and thereby the virtual work expression (density is constant) simplifies to

$$\delta W^2 = -\delta a (-1 + a) L C A a \left(-a + \frac{1}{2} a\right).$$

Virtual work expression of the point force follows e.g. directly from the definition (force multiplied by the virtual displacement in its direction)

$$\delta W^3 = -\delta u_{X1} F = -\delta a L F.$$

Virtual work expression of a structure is the sum of element contributions

$$\delta W = -\delta a \left[\frac{1}{2} a \frac{L^2}{2} \frac{tC}{1-\nu^2} (a^2 + 1 - \nu) + (-1 + a) L C A a \left(-a + \frac{1}{2} a\right) + L F \right].$$

Principle of virtual work and the fundamental lemma of variation calculus give

$$\frac{L}{4} \frac{tC}{1-\nu^2} a (a^2 + 1 - \nu) + C A (-1 + a) a \left(-a + \frac{1}{2} a\right) + F = 0. \quad \leftarrow$$

A long wall having triangular cross-section, and made of homogeneous, isotropic, linearly elastic material, is subjected to its own weight. Determine the equilibrium equation giving as its solution displacement components u_{Y3} according to the large displacement theory. Nodes 1 and 2 are fixed. Use a three-node element and assume plane stress conditions and symmetry $u_{X3} = 0$. Material properties C , ν and the density ρ of the initial geometry are constants.

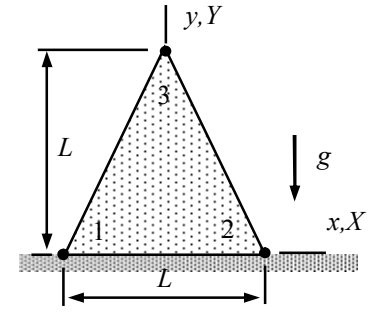

Solution

According to the large displacement theory, virtual work densities of the thin slab model under plane strain conditions are

$$\delta w_{\Omega^0}^{\text{int}} = - \begin{Bmatrix} \delta E_{xx} \\ \delta E_{yy} \\ 2\delta E_{xy} \end{Bmatrix}^T \frac{tE}{1-\nu^2} \begin{bmatrix} 1 & \nu & 0 \\ \nu & 1 & 0 \\ 0 & 0 & (1-\nu)/2 \end{bmatrix} \begin{Bmatrix} E_{xx} \\ E_{yy} \\ 2E_{xy} \end{Bmatrix}, \quad \begin{Bmatrix} E_{xx} \\ E_{yy} \\ 2E_{xy} \end{Bmatrix} = \begin{Bmatrix} \frac{\partial u}{\partial x} + \frac{1}{2} \left(\frac{\partial u}{\partial x} \right)^2 + \frac{1}{2} \left(\frac{\partial v}{\partial x} \right)^2 \\ \frac{\partial v}{\partial y} + \frac{1}{2} \left(\frac{\partial u}{\partial y} \right)^2 + \frac{1}{2} \left(\frac{\partial v}{\partial y} \right)^2 \\ \frac{\partial u}{\partial y} + \frac{\partial v}{\partial x} + \frac{\partial u}{\partial x} \frac{\partial u}{\partial y} + \frac{\partial v}{\partial x} \frac{\partial v}{\partial y} \end{Bmatrix},$$

$$\delta w_{\Omega^0}^{\text{ext}} = \begin{Bmatrix} \delta u \\ \delta v \end{Bmatrix}^T t\rho^0 \begin{Bmatrix} g_x \\ g_y \end{Bmatrix}$$

in which g_x and g_y are the components of acceleration by gravity and ρ^0 the density at the initial geometry. Above, constitutive equation is assumed to be of the same form as that for the linear theory with possibly different elasticity parameters C and ν .

Shape function $N_3 = y/L$ of node 3 can be deduced from the figure. Linear approximations to the displacement components and their derivatives are

$$u = 0 \quad \text{and} \quad v = \frac{y}{L} u_{Y3} \quad \Rightarrow \quad \frac{\partial u}{\partial x} = 0, \quad \frac{\partial u}{\partial y} = 0, \quad \frac{\partial v}{\partial x} = 0, \quad \text{and} \quad \frac{\partial v}{\partial y} = \frac{u_{Y3}}{L}.$$

When the approximation is substituted there, the non-zero Green-Lagrange strain component and its variation take the forms

$$E_{yy} = \frac{u_{Y3}}{L} + \frac{1}{2} \left(\frac{u_{Y3}}{L} \right)^2 \quad \text{and} \quad \delta E_{yy} = \frac{\delta u_{Y3}}{L} + \frac{\delta u_{Y3}}{L} \frac{u_{Y3}}{L}.$$

Virtual work densities simplify to

$$\delta w_{\Omega^0}^{\text{int}} = - \frac{\delta u_{Y3}}{L} \left(1 + \frac{u_{Y3}}{L} \right) \frac{tE}{1-\nu^2} \frac{u_{Y3}}{L} \left(1 + \frac{1}{2} \frac{u_{Y3}}{L} \right),$$

$$\delta w_{\Omega^0}^{\text{ext}} = -\delta u_{Y3} \frac{y}{L} t\rho g.$$

Integration over the domain occupied by the body at the initial geometry gives the virtual work expressions

$$\delta W^{\text{int}} = -\frac{\delta u_{Y3}}{L} \left(1 + \frac{u_{Y3}}{L}\right) \frac{L^2}{2} \frac{tE}{1-\nu^2} \frac{u_{Y3}}{L} \left(1 + \frac{1}{2} \frac{u_{Y3}}{L}\right),$$

$$\delta W^{\text{ext}} = \int_0^L \left(\int_{(y-L)/2}^{(L-y)/2} \delta w_{\Omega^{\circ}}^{\text{ext}} dx \right) dy = -\frac{\delta u_{Y3}}{L} \frac{L^3 t \rho g}{6}.$$

Virtual work expression in the sum of the internal and external parts. Written in the standard form

$$\delta W = -\frac{\delta u_{Y3}}{L} \left[\left(1 + \frac{u_{Y3}}{L}\right) \frac{L^2}{2} \frac{tE}{1-\nu^2} \frac{u_{Y3}}{L} \left(1 + \frac{1}{2} \frac{u_{Y3}}{L}\right) + \frac{L^3 t \rho g}{6} \right].$$

Principle of virtual work and the fundamental lemma of variation calculus imply the equilibrium equations

$$(1+a)a\left(1 + \frac{1}{2}a\right) + \frac{1}{3}(1-\nu^2) \frac{L\rho g}{E} = 0 \quad \text{where } a = \frac{u_{Y3}}{L}. \quad \leftarrow$$

Node 4 of a thin rectangular slab, loaded by force F , is allowed to move horizontally and nodes 1, 2, and 3 are fixed. Assume plane stress conditions, and derive the equilibrium equation of the structure according to the large deformation theory. Use just one bilinear element. Material parameters C and $\nu = 0$. Thickness of the slab at the initial geometry is t .

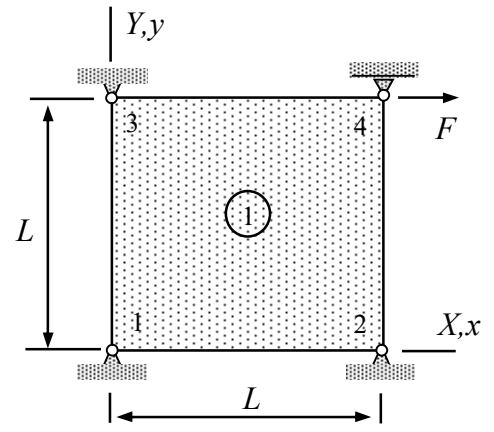

Solution

According to the large displacement theory, virtual work density of the thin slab model (plane stress condition) is

$$\delta w_{\Omega^0}^{\text{int}} = - \begin{Bmatrix} \delta E_{xx} \\ \delta E_{yy} \\ 2\delta E_{xy} \end{Bmatrix}^T \frac{tC}{1-\nu^2} \begin{bmatrix} 1 & \nu & 0 \\ \nu & 1 & 0 \\ 0 & 0 & (1-\nu)/2 \end{bmatrix} \begin{Bmatrix} E_{xx} \\ E_{yy} \\ 2E_{xy} \end{Bmatrix}, \quad \begin{Bmatrix} E_{xx} \\ E_{yy} \\ 2E_{xy} \end{Bmatrix} = \begin{Bmatrix} \frac{\partial u}{\partial x} + \frac{1}{2} \left(\frac{\partial u}{\partial x} \right)^2 + \frac{1}{2} \left(\frac{\partial v}{\partial x} \right)^2 \\ \frac{\partial v}{\partial y} + \frac{1}{2} \left(\frac{\partial u}{\partial y} \right)^2 + \frac{1}{2} \left(\frac{\partial v}{\partial y} \right)^2 \\ \frac{\partial u}{\partial y} + \frac{\partial v}{\partial x} + \frac{\partial u}{\partial x} \frac{\partial u}{\partial y} + \frac{\partial v}{\partial x} \frac{\partial v}{\partial y} \end{Bmatrix}.$$

Only the displacement of node 4 in the X – direction matters. Shape function $N_4 = xy/L^2$ gives

$$\nu = 0 \quad \text{and} \quad u = xy \frac{u_{X4}}{L^2} \Rightarrow \frac{\partial u}{\partial x} = y \frac{u_{X4}}{L^2} \quad \text{and} \quad \frac{\partial u}{\partial y} = x \frac{u_{X4}}{L^2}.$$

When the approximations are substituted there, the Green-Lagrange strain components and their variations simplify to

$$\begin{Bmatrix} E_{xx} \\ E_{yy} \\ 2E_{xy} \end{Bmatrix} = \frac{u_{X4}}{L^2} \begin{Bmatrix} y \\ 0 \\ x \end{Bmatrix} + \frac{1}{2} \left(\frac{u_{X4}}{L^2} \right)^2 \begin{Bmatrix} y^2 \\ x^2 \\ 2xy \end{Bmatrix} \quad \text{and} \quad \begin{Bmatrix} \delta E_{xx} \\ \delta E_{yy} \\ 2\delta E_{xy} \end{Bmatrix} = \frac{\delta u_{X4}}{L^2} \left(\begin{Bmatrix} y \\ 0 \\ x \end{Bmatrix} + \frac{u_{X4}}{L^2} \begin{Bmatrix} y^2 \\ x^2 \\ 2xy \end{Bmatrix} \right).$$

Virtual work density of the internal forces according to the large displacement theory simplify to (with the Poisson's ratio $\nu = 0$)

$$\delta w_{\Omega^0}^{\text{int}} = - \frac{\delta u_{X4}}{L^2} \left[\begin{Bmatrix} y \\ 0 \\ x \end{Bmatrix} + \frac{u_{X4}}{L^2} \begin{Bmatrix} y^2 \\ x^2 \\ 2xy \end{Bmatrix} \right]^T tC \begin{bmatrix} 1 & 0 & 0 \\ 0 & 1 & 0 \\ 0 & 0 & 1/2 \end{bmatrix} \left[\frac{u_{X4}}{L^2} \begin{Bmatrix} y \\ 0 \\ x \end{Bmatrix} + \frac{1}{2} \left(\frac{u_{X4}}{L^2} \right)^2 \begin{Bmatrix} y^2 \\ x^2 \\ 2xy \end{Bmatrix} \right],$$

The four terms of the virtual work density

$$(\delta w_{\Omega^0}^{\text{int}})_1 = - \frac{\delta u_{X4}}{L} \frac{tC}{L^2} \left(y^2 + \frac{1}{2} x^2 \right) \frac{u_{X4}}{L},$$

$$(\delta w_{\Omega^{\circ}}^{\text{int}})_2 = -\frac{\delta u_{X4}}{L} \frac{tC}{L} (y^3 + x^2 y) \frac{1}{2} \left(\frac{u_{X4}}{L}\right)^2,$$

$$(\delta w_{\Omega^{\circ}}^{\text{int}})_3 = -\frac{\delta u_{X4}}{L} \frac{u_{X4}}{L} \frac{tC}{L^3} (y^3 + x^2 y) \frac{u_{X4}}{L},$$

$$(\delta w_{\Omega^{\circ}}^{\text{int}})_4 = -\frac{\delta u_{X4}}{L} \frac{u_{X4}}{L} \frac{tC}{L^2} (y^4 + x^4 + 2x^2 y^2) \frac{1}{2} \left(\frac{u_{X4}}{L}\right)^2.$$

Virtual work expressions are obtained by integrating the densities over the domain occupied by the element

$$\delta W_1^{\text{int}} = \int_0^L \int_0^L (\delta w_{\Omega^{\circ}}^{\text{int}})_1 dy dx = -\frac{\delta u_{X4}}{L} \frac{1}{2} L^2 tC \frac{u_{X4}}{L},$$

$$\delta W_2^{\text{int}} = \int_0^L \int_0^L (\delta w_{\Omega^{\circ}}^{\text{int}})_2 dy dx = -\frac{\delta u_{X4}}{L} tCL^2 \frac{5}{24} \left(\frac{u_{X4}}{L}\right)^2,$$

$$\delta W_3^{\text{int}} = \int_0^L \int_0^L (\delta w_{\Omega^{\circ}}^{\text{int}})_3 dy dx = -\frac{\delta u_{X4}}{L} \frac{u_{X4}}{L} tCL^2 \frac{5}{12} \frac{u_{X4}}{L},$$

$$\delta W_4^{\text{int}} = \int_0^L \int_0^L (\delta w_{\Omega^{\circ}}^{\text{int}})_4 dy dx = -\frac{\delta u_{X4}}{L} \frac{u_{X4}}{L} tCL^2 \frac{14}{45} \left(\frac{u_{X4}}{L}\right)^2.$$

Virtual work expression of the point force

$$\delta W^{\text{ext}} = FL \frac{\delta u_{X4}}{L}.$$

Virtual work expression is the sum of the terms. In terms of the dimensionless displacement $a = u_{X4} / L$

$$\delta W = -tCL^2 \delta a \left(\frac{1}{2} a + \frac{5}{8} a^2 + \frac{14}{45} a^3 - \frac{F}{tLC} \right).$$

Principle of virtual work and the fundamental lemma of variation calculus imply the equilibrium equation

$$\frac{1}{2} a + \frac{5}{8} a^2 + \frac{14}{45} a^3 - \frac{F}{tLC} = 0. \quad \leftarrow$$