

# MEC-E1050 Finite Element Method in Solid, week 49/2021

1. Consider a cantilever in  $xy$ -plane loaded by its own weight. Determine the displacement and rotation of the free end. Density  $\rho$ , Young's modulus  $E$ , Poisson's ratio  $\nu$  are constants, and cross-section is rectangle of side length  $t$ . Use one element and Bernoulli beam model with the bar and bending modes.

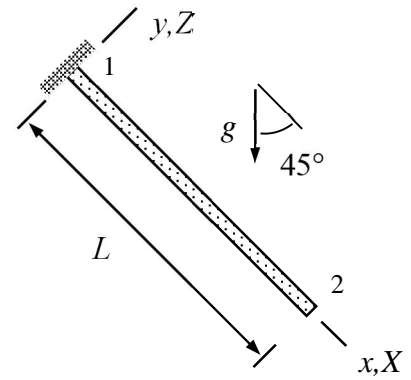

**Answer**  $u_{X2} = \frac{1}{2\sqrt{2}} \frac{\rho g L^2}{E}$ ,  $u_{Z2} = -\frac{3}{2\sqrt{2}} \frac{\rho g L^4}{Et^2}$ ,  $\theta_{Y2} = \sqrt{2} \frac{\rho g L^3}{Et^2}$ .

2. Determine rotation of the Bernoulli beam of the figure at the support of the right end (use one element). The neutral axis coincides with the  $x$ -axis of the material coordinate system and the support does not allow displacement *at the  $x$ -axis*. Material property  $E$  is constant.

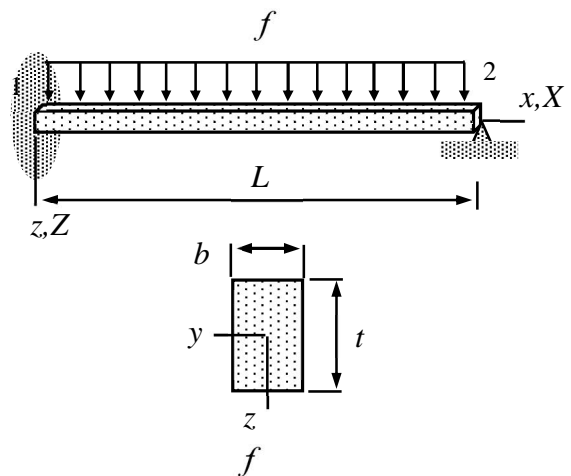

**Answer**  $\theta_{Y2} = \frac{1}{4} \frac{fL^3}{Ebt^3}$

3. Determine the rotation of the Bernoulli beam in the figure at node 2. The  $x$ -axis of the material coordinate system is placed as shown and the support at node 2 does not allow displacement *at the  $x$ -axis*. Young's modulus of the material  $E$  is constant. Use quadratic approximation (three nodes) to the axial displacement  $u$ .

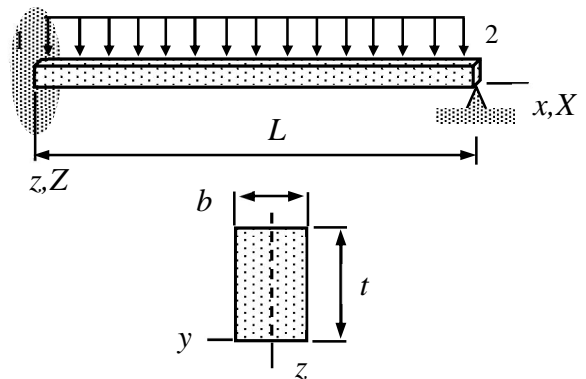

**Answer**  $\theta_{Y2} = \frac{1}{7} \frac{fL^3}{Ebt^3}$

4. A plate is loaded in its plane by shear force  $F$  distributed evenly as shown in the figure. Determine the displacement at the free end. Use thin-slab mode virtual work density of the plate model and a four-node element. Material properties  $E$ ,  $\nu$ ,  $\rho$  and thickness  $t$  are constants. Assume that  $u_{Y4} = u_{Y2}$ .

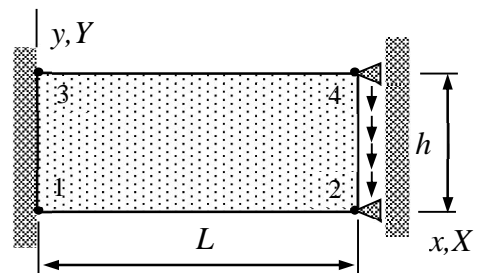

**Answer**  $u_{Y2} = -2 \frac{LF}{htE} (1+\nu) = -\frac{LF}{htG}$

5. A plate is loaded in its plane by shear force  $F$  distributed evenly as shown. Determine the displacement of the free end. Use the virtual work density expressions of the thin-slab mode of the plate model and a four-node element. Material properties  $E$ ,  $\nu=0$ ,  $\rho$  and thickness  $t$  are constants. Assume that  $u_{Y4} = u_{Y2}$  and  $u_{X4} = -u_{X2}$  and consider the slender plate limit  $h/L \ll 1$ .

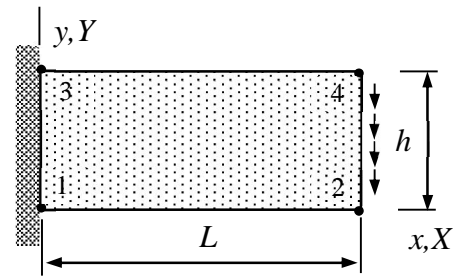

**Answer**  $u_{X2} = -6 \frac{F}{tE}$ ,  $u_{Y2} = -8 \frac{FL}{tEh}$

6. Consider the plate strip shown loaded by its own weight. Thickness, length and width of the plate are  $t$ ,  $L$ , and  $H$ , respectively. Density  $\rho$ , Young's modulus  $E$ , and Poisson's ratio  $\nu$  are constants. Find an approximation to the transverse displacement  $w$  of the plate using series  $w = a_0(1-x/L)(x/L)$  (just one term of a series) in which  $a_0$  is an unknown parameter.

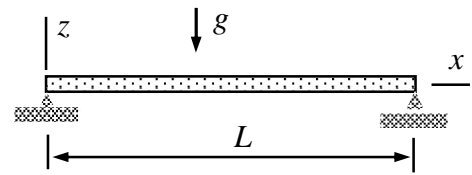

**Answer**  $w(x, y) = -\frac{1}{2} \frac{L^4 \rho g}{t^2 E} (1-\nu^2) (1-\frac{x}{L}) \frac{x}{L}$

7. A plate, loaded by point force  $F$  acting at the free corner, is simply supported on two edges and free on the other two edges as shown in the figure. Determine the parameter  $a_0$  of approximation  $w(x, y) = a_0(x/L)(y/L)$  and displacement at the center point. Use the virtual work density of the plate bending mode with constant  $E$ ,  $\nu$ ,  $\rho$  and  $t$ .

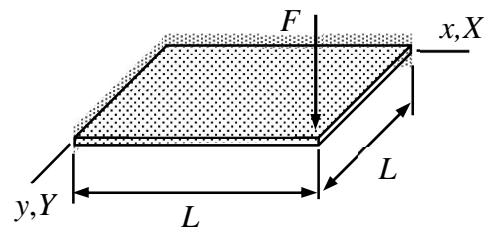

**Answer**  $a_0 = 6 \frac{FL^2}{Et^3} (1+\nu)$ ,  $w(\frac{L}{2}, \frac{L}{2}) = \frac{3}{2} \frac{FL^2}{Et^3} (1+\nu)$

8. A simply supported plate is loaded by force  $F$  acting at the center as shown in the figure. Determine the displacement  $w(x, y)$  by using the principle of virtual work. Consider the plate bending mode only and use approximation  $w = a_0 \sin(\pi x/L) \sin(\pi y/L)$  in which  $a_0$  is a parameter. Material properties  $E$ ,  $\nu$ ,  $\rho$  and thickness  $t$  are constants. The shape functions of the approximation satisfy, e.g.,

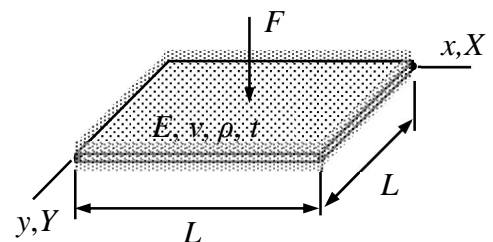

$$\int_0^L \sin(i\pi \frac{x}{L}) \sin(j\pi \frac{x}{L}) dx = \frac{L}{2} \delta_{ij}.$$

**Answer**  $w(x, y) = \frac{12 FL^2}{\pi^4 Et^3} (1-\nu^2) \sin(\pi \frac{x}{L}) \sin(\pi \frac{y}{L})$

9. A simply supported plate is loaded by its own weight as shown. Use the bending mode virtual work density of the plate model to find the displacement. Use approximation  $w = a_0(1-\xi)\xi(1-\eta)\eta$  in which  $a_0$  is the parameter to be determined and the scaled coordinates  $\xi = x/L$  and  $\eta = y/L$ . Material properties  $E, \nu, \rho$  and thickness  $t$  are constants.

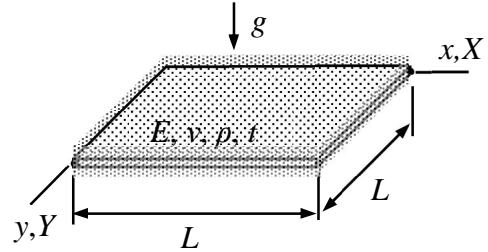

**Answer**  $w = \frac{15 g \rho L^4 (1-\nu^2)}{22 Et^2} (1-\frac{x}{L}) \frac{x}{L} (1-\frac{y}{L}) \frac{y}{L}$

10. At point  $x=L/4$  and  $y=L/2$  of a 4-noded plate element there is a point moment with magnitude  $M$ . Determine the virtual work expression  $\delta W^{\text{ext}}$  of the moment for a Reissner-Mindlin plate element. Assume that nodes 1,2,4 are fixed and that the approximations to all unknown functions are bi-linear.

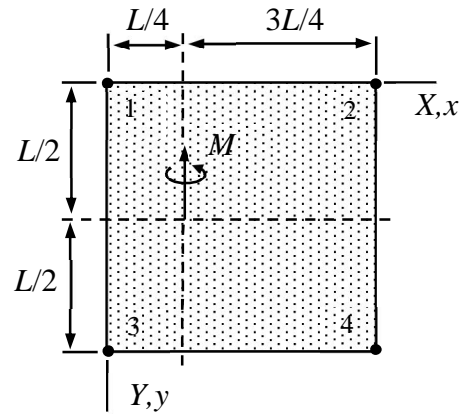

**Answer**  $\delta W^{\text{ext}} = -\frac{3}{8} M \delta \theta_{Y3}$ .

Consider a cantilever in  $xy$ -plane loaded by its own weight. Determine the displacement and rotation of the free end. Density  $\rho$ , Young's modulus  $E$ , Poisson's ratio  $\nu$  are constants, and cross-section is rectangle of side length  $t$ . Use one element and Bernoulli beam model with the bar and bending modes.

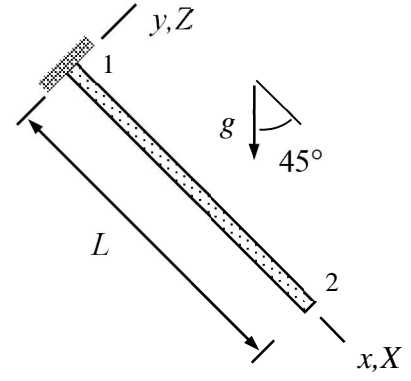

### Solution

Assuming that the material coordinate system is chosen so that the bending and stretching modes decouple, the two modes can be taken into account as if they were separate elements. Therefore, one may use the virtual work expressions for the beam  $xy$ -plane bending and bar modes of the formulae collection

$$\delta W^{\text{int}} = - \begin{Bmatrix} \delta u_{y1} \\ \delta \theta_{z1} \\ \delta u_{y2} \\ \delta \theta_{z2} \end{Bmatrix}^T \frac{EI_{zz}}{h^3} \begin{bmatrix} 12 & 6h & -12 & 6h \\ 6h & 4h^2 & -6h & 2h^2 \\ -12 & -6h & 12 & -6h \\ 6h & 2h^2 & -6h & 4h^2 \end{bmatrix} \begin{Bmatrix} u_{y1} \\ \theta_{z1} \\ u_{y2} \\ \theta_{z2} \end{Bmatrix}, \quad \delta W^{\text{ext}} = \begin{Bmatrix} \delta u_{y1} \\ \delta \theta_{z1} \\ \delta u_{y2} \\ \delta \theta_{z2} \end{Bmatrix}^T \frac{f_y h}{12} \begin{Bmatrix} 6 \\ h \\ 6 \\ -h \end{Bmatrix},$$

$$\delta W^{\text{int}} = - \begin{Bmatrix} \delta u_{x1} \\ \delta u_{x2} \end{Bmatrix}^T \frac{EA}{h} \begin{bmatrix} 1 & -1 \\ -1 & 1 \end{bmatrix} \begin{Bmatrix} u_{x1} \\ u_{x2} \end{Bmatrix}, \quad \delta W^{\text{ext}} = \begin{Bmatrix} \delta u_{x1} \\ \delta u_{x2} \end{Bmatrix}^T \frac{f_x h}{2} \begin{Bmatrix} 1 \\ 1 \end{Bmatrix}.$$

The nodal displacements and rotations of the material coordinate systems need to be expressed in terms of those of the structural coordinate system. By using the figure

$$u_{x1} = 0, \quad u_{y1} = 0, \quad \theta_{z1} = 0,$$

$$u_{x2} = u_{X2}, \quad u_{y2} = u_{Z2}, \quad \theta_{z2} = -\theta_{Y2}.$$

The cross-section properties and the distributed force (per unit length) components in the material coordinate system are

$$A = t^2, \quad I_{zz} = \frac{1}{12}t^4, \quad f_x = \frac{1}{\sqrt{2}}t^2\rho g, \quad f_y = -\frac{1}{\sqrt{2}}t^2\rho g.$$

When these relationships are used in the element contribution of the beam bending mode, the generic expressions simplify to

$$\delta W^{\text{int}} = - \begin{Bmatrix} \delta u_{Z2} \\ \delta \theta_{Y2} \end{Bmatrix}^T \begin{bmatrix} \frac{Et^4}{L^3} & \frac{Et^4}{2L^2} \\ \frac{Et^4}{2L^2} & \frac{Et^4}{3L} \end{bmatrix} \begin{Bmatrix} u_{Z2} \\ \theta_{Y2} \end{Bmatrix} \quad \text{and} \quad \delta W^{\text{ext}} = \begin{Bmatrix} \delta u_{Z2} \\ \delta \theta_{Y2} \end{Bmatrix}^T \begin{Bmatrix} -\frac{1}{2\sqrt{2}}t^2\rho gL \\ -\frac{1}{12\sqrt{2}}t^2\rho gL^2 \end{Bmatrix}.$$

The bar mode expressions take the forms

$$\delta W^{\text{int}} = -\delta u_{X2} \frac{Et^2}{L} u_{X2} \quad \text{and} \quad \delta W^{\text{ext}} = \delta u_{X2} \frac{1}{2\sqrt{2}} t^2 \rho g L.$$

Virtual work expression is the sum of the mode expressions

$$\delta W = - \begin{Bmatrix} \delta u_{X2} \\ \delta u_{Z2} \\ \delta \theta_{Y2} \end{Bmatrix}^T \begin{bmatrix} \frac{Et^2}{L} & 0 & 0 \\ 0 & \frac{Et^4}{L^3} & \frac{Et^4}{2L^2} \\ 0 & \frac{Et^4}{2L^2} & \frac{Et^4}{3L} \end{bmatrix} \begin{Bmatrix} u_{X2} \\ u_{Z2} \\ \theta_{Y2} \end{Bmatrix} - \begin{Bmatrix} \frac{1}{2\sqrt{2}} t^2 \rho g L \\ -\frac{1}{2\sqrt{2}} t^2 \rho g L \\ -\frac{1}{12\sqrt{2}} t^2 \rho g L^2 \end{Bmatrix}.$$

Principle of virtual work and the fundamental lemma of variational calculus imply the linear equation system

$$\begin{bmatrix} \frac{Et^2}{L} & 0 & 0 \\ 0 & \frac{Et^4}{L^3} & \frac{Et^4}{2L^2} \\ 0 & \frac{Et^4}{2L^2} & \frac{Et^4}{3L} \end{bmatrix} \begin{Bmatrix} u_{X2} \\ u_{Z2} \\ \theta_{Y2} \end{Bmatrix} - \begin{Bmatrix} \frac{1}{2\sqrt{2}} t^2 \rho g L \\ -\frac{1}{2\sqrt{2}} t^2 \rho g L \\ -\frac{1}{12\sqrt{2}} t^2 \rho g L^2 \end{Bmatrix} = 0.$$

The first equation is not connected to the second and third. Therefore, the solution can be found without inverting the 3-by-3 matrix (the bending mode equations are connected so a 2-by-2 matrix needs to be inverted)

$$u_{X2} = \frac{1}{2\sqrt{2}} \frac{\rho g L^2}{E}, \quad u_{Z2} = -\frac{3}{2\sqrt{2}} \frac{\rho g L^4}{Et^2} \quad \text{and} \quad \theta_{Y2} = \sqrt{2} \frac{\rho g L^3}{Et^2}. \quad \leftarrow$$

Determine rotation of the Bernoulli beam of the figure at the support of the right end (use one element). The neutral axis coincides with the  $x$ -axis of the material coordinate system and the support does not allow displacement *at the  $x$ -axis*. Material property  $E$  is constant.

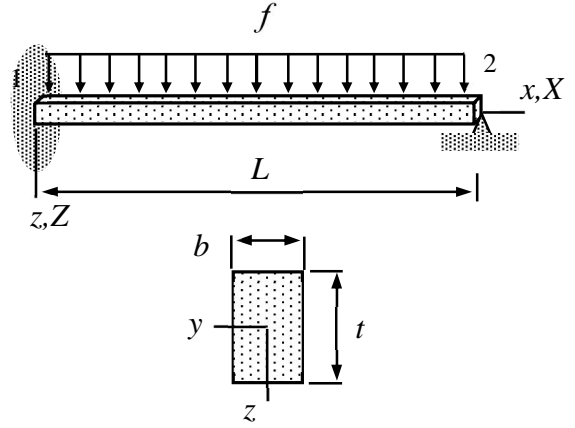

### Solution

Virtual work densities of the Bernoulli beam model taking into account all the modes

$$\delta w_{\Omega}^{\text{int}} = - \begin{Bmatrix} d\delta u / dx \\ d^2\delta v / dx^2 \\ d^2\delta w / dx^2 \end{Bmatrix}^T E \begin{bmatrix} A & -S_z & -S_y \\ -S_z & I_{zz} & I_{zy} \\ -S_y & I_{yz} & I_{yy} \end{bmatrix} \begin{Bmatrix} du / dx \\ d^2v / dx^2 \\ d^2w / dx^2 \end{Bmatrix} - \frac{d\delta\phi}{dx} GI_{rr} \frac{d\phi}{dx},$$

$$\delta w_{\Omega}^{\text{ext}} = \begin{Bmatrix} \delta u \\ \delta v \\ \delta w \end{Bmatrix}^T \begin{Bmatrix} f_x \\ f_y \\ f_z \end{Bmatrix} + \begin{Bmatrix} \delta\phi \\ -d\delta w / dx \\ d\delta v / dx \end{Bmatrix}^T \begin{Bmatrix} m_x \\ m_y \\ m_z \end{Bmatrix}$$

depend on the material properties  $E, G$  and on the moments of area  $A, S_y, S_z, I_{yy}, I_{zz}, I_{yz}$ , and  $I_{rr} = I_{yy} + I_{zz}$ . Expressions take the simplest form when  $x$ -axis is chosen to coincide with the neutral axis and  $y$  and  $z$  are symmetry axes of the cross-section.

Approximations to the unknown functions is the first thing to be considered. The left end of the beam is clamped and the right end simply supported. As the  $x$ -axis coincides with the neutral axis and the beam is not loaded in the direction of its axis, only the transverse displacement needs to be considered. Approximation to the transverse displacement  $w$  simplifies to

$$w = \left(\frac{x}{L}\right)^2 \left(1 - \frac{x}{L}\right) \theta_{Y2} \quad \Rightarrow \quad \frac{d^2w}{dx^2} = \frac{1}{L} \left(2 - 6\frac{x}{L}\right) \theta_{Y2}.$$

Virtual work density depends on the moments of cross-section  $A = bt, S_y = 0, S_z = 0$  and  $I_{yy} = I = bt^3 / 12$ . When the approximation is substituted there, virtual work densities simplify to

$$\delta w_{\Omega}^{\text{int}} = - \frac{d^2\delta w}{dx^2} EI \frac{d^2w}{dx^2} = -\delta\theta_{Y2} \frac{EI}{L^2} \left(2 - 6\frac{x}{L}\right)^2 \theta_{Y2},$$

$$\delta w_{\Omega}^{\text{ext}} = \delta w f_z = \delta\theta_{Y2} L \left(\frac{x}{L}\right)^2 \left(1 - \frac{x}{L}\right) f.$$

Virtual work expressions are integrals of the densities over the element domain  $\Omega = ]0, L[$

$$\delta W^{\text{int}} = \int_{\Omega} \delta w_{\Omega}^{\text{int}} d\Omega = -\delta\theta_{Y2} 4 \frac{EI}{L} \theta_{Y2},$$

$$\delta W^{\text{ext}} = \int_{\Omega} \delta w_{\Omega}^{\text{ext}} d\Omega = \delta\theta_{Y2} \frac{fL^2}{12}.$$

Principle of virtual work  $\delta W = \delta W^{\text{int}} + \delta W^{\text{ext}} = 0 \quad \forall \delta \mathbf{a}$  and the fundamental lemma of variation calculus give

$$\delta W = -\delta\theta_{Y2} \left( 4 \frac{EI}{L} \theta_{Y2} - \frac{fL^2}{12} \right) = 0 \quad \forall \delta\theta_{Y2} \quad \Leftrightarrow \quad 4 \frac{EI}{L} \theta_{Y2} - \frac{fL^2}{12} = 0 \quad \Leftrightarrow$$

$$\theta_{Y2} = \frac{1}{48} \frac{fL^3}{EI} = \frac{1}{4} \frac{fL^3}{Ebt^3}. \quad \leftarrow$$

Solution follows also from the virtual work expression of the formulae collection

$$\delta W = - \begin{Bmatrix} 0 \\ 0 \\ 0 \\ \delta\theta_{Y2} \end{Bmatrix}^T \left( \frac{EI}{L^3} \begin{bmatrix} 12 & -6L & -12 & -6L \\ -6L & 4L^2 & 6L & 2L^2 \\ -12 & 6L & 12 & 6L \\ -6L & 2L^2 & 6L & 4L^2 \end{bmatrix} \begin{Bmatrix} 0 \\ 0 \\ 0 \\ \theta_{Y2} \end{Bmatrix} - \frac{fL}{12} \begin{Bmatrix} 6 \\ -L \\ 6 \\ L \end{Bmatrix} \right) = -\delta\theta_{Y2} \left( \frac{EI}{L^3} 4L^2 \theta_{Y2} - \frac{fL^2}{12} \right)$$

which is valid when the  $x$ -axis of the material coordinate system coincides with the neutral axis of the beam (and  $y$ - and  $z$ - axes are symmetry axes of the cross-section):

Determine the rotation of the Bernoulli beam in the figure at node 2. The  $x$ -axis of the material coordinate system is placed as shown and the support at node 2 does not allow displacement *at the  $x$ -axis*. Young's modulus of the material  $E$  is constant. Use quadratic approximation (three nodes) to the axial displacement  $u$ .

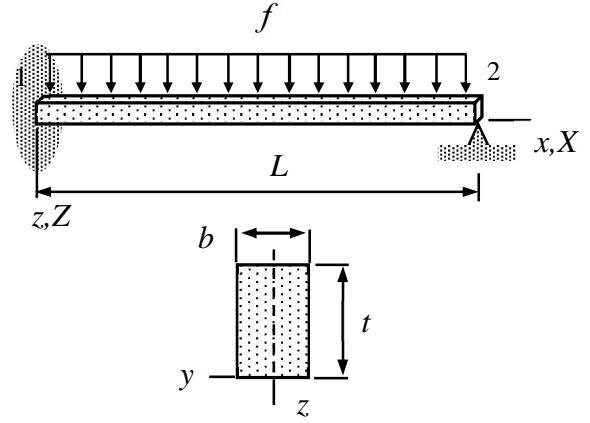

### Solution

Virtual work densities of the Bernoulli beam model

$$\delta w_{\Omega}^{\text{int}} = - \begin{Bmatrix} d\delta u / dx \\ d^2\delta v / dx^2 \\ d^2\delta w / dx^2 \end{Bmatrix}^T E \begin{bmatrix} A & -S_z & -S_y \\ -S_z & I_{zz} & I_{zy} \\ -S_y & I_{yz} & I_{yy} \end{bmatrix} \begin{Bmatrix} du / dx \\ d^2v / dx^2 \\ d^2w / dx^2 \end{Bmatrix} - \frac{d\delta\phi}{dx} GI_{rr} \frac{d\phi}{dx},$$

$$\delta w_{\Omega}^{\text{ext}} = \begin{Bmatrix} \delta u \\ \delta v \\ \delta w \end{Bmatrix}^T \begin{Bmatrix} f_x \\ f_y \\ f_z \end{Bmatrix} + \begin{Bmatrix} \delta\phi \\ -d\delta w / dx \\ d\delta v / dx \end{Bmatrix}^T \begin{Bmatrix} m_x \\ m_y \\ m_z \end{Bmatrix}$$

depend on the material properties  $E, G$  and on the moments of the area  $A, S_y, S_z, I_{yy}, I_{zz}, I_{yz}$ , and  $I_{rr} = I_{yy} + I_{zz}$ .

The left end of the beam is clamped and the right end simply supported. The additional node 3 for the quadratic approximation is places at the mid-point of the beam. Approximations to  $u$  and  $w$  become

$$u = \begin{Bmatrix} 1-3\xi+2\xi^2 \\ 4\xi(1-\xi) \\ \xi(2\xi-1) \end{Bmatrix}^T \begin{Bmatrix} 0 \\ u_{X3} \\ 0 \end{Bmatrix} = 4 \frac{x}{L} (1-\frac{x}{L}) u_{X3} \Rightarrow \frac{du}{dx} = 4 \frac{1}{L} (1-2\frac{x}{L}) u_{X3}.$$

$$w = \begin{Bmatrix} (1-\xi)^2(1+2\xi) \\ L(1-\xi)^2\xi \\ (3-2\xi)\xi^2 \\ L\xi^2(\xi-1) \end{Bmatrix}^T \begin{Bmatrix} 0 \\ 0 \\ 0 \\ -\theta_{Y2} \end{Bmatrix} = L(\frac{x}{L})^2(1-\frac{x}{L})\theta_{Y2} \Rightarrow \frac{d^2w}{dx^2} = \frac{1}{L} 2(1-3\frac{x}{L})\theta_{Y2}.$$

Virtual work densities depend on the moments of cross-section

$$A = bt, S_z = 0, S = S_y = \int_{-t}^0 zbdz = -bt^2/2 \text{ and } I = I_{yy} = \int_{-t}^0 z^2bdz = bt^3/3.$$

When the approximations are substituted there, virtual work densities simplify to



$$\delta w_{\Omega}^{\text{int}} = - \left\{ \begin{array}{c} d\delta u / dx \\ d^2\delta w / dx^2 \end{array} \right\}^T \begin{bmatrix} EA & -ES \\ -ES & EI \end{bmatrix} \left\{ \begin{array}{c} du / dx \\ d^2w / dx^2 \end{array} \right\} \quad \text{and} \quad \delta w_{\Omega}^{\text{ext}} = \left\{ \begin{array}{c} \delta u \\ \delta w \end{array} \right\}^T \left\{ \begin{array}{c} 0 \\ \rho g A \end{array} \right\} \Rightarrow$$

$$\delta w_{\Omega}^{\text{int}} = - \left\{ \begin{array}{c} \delta u_{X3} \\ \delta \theta_{Y2} \end{array} \right\}^T \frac{4E}{L^2} \begin{bmatrix} A4(1-2x/L)^2 & -S2(1-3x/L)(1-2x/L) \\ -S2(1-3x/L)(1-2x/L) & I(1-3x/L)^2 \end{bmatrix} \left\{ \begin{array}{c} u_{X3} \\ \theta_{Y2} \end{array} \right\},$$

$$\delta w_{\Omega}^{\text{ext}} = \left\{ \begin{array}{c} \delta u_{X3} \\ \delta \theta_{Y2} \end{array} \right\}^T \left\{ \begin{array}{c} 0 \\ L(x/L)^2(1-x/L)f \end{array} \right\}.$$

Virtual work expressions are integrals of the densities over the mathematical solution domain.

Integrations over  $\Omega = ]0, L[$  give the virtual work expressions

$$\delta W^{\text{int}} = \int_{\Omega} \delta w_{\Omega}^{\text{int}} d\Omega = - \left\{ \begin{array}{c} \delta u_{X3} \\ \delta \theta_{Y2} \end{array} \right\}^T \frac{4E}{L} \begin{bmatrix} 4A/3 & -S \\ -S & I \end{bmatrix} \left\{ \begin{array}{c} u_{X3} \\ \theta_{Y2} \end{array} \right\},$$

$$\delta W^{\text{ext}} = \int_{\Omega} \delta w_{\Omega}^{\text{ext}} d\Omega = \left\{ \begin{array}{c} \delta u_{X3} \\ \delta \theta_{Y2} \end{array} \right\}^T \frac{fL^2}{12} \left\{ \begin{array}{c} 0 \\ 1 \end{array} \right\}.$$

Principle of virtual work  $\delta W = \delta W^{\text{int}} + \delta W^{\text{ext}} = 0 \quad \forall \delta \mathbf{a}$  and the fundamental lemma of variation calculus give

$$\delta W = - \left\{ \begin{array}{c} \delta u_{X3} \\ \delta \theta_{Y2} \end{array} \right\}^T \left( 4 \frac{Ebt}{L} \begin{bmatrix} 4/3 & t/2 \\ t/2 & t^2/3 \end{bmatrix} \left\{ \begin{array}{c} u_{X3} \\ \theta_{Y2} \end{array} \right\} - \frac{fL^2}{12} \left\{ \begin{array}{c} 0 \\ 1 \end{array} \right\} \right) = 0 \quad \forall \left\{ \begin{array}{c} \delta u_{X3} \\ \delta \theta_{Y2} \end{array} \right\} \Leftrightarrow$$

$$4 \frac{Ebt}{L} \begin{bmatrix} 4/3 & t/2 \\ t/2 & t^2/3 \end{bmatrix} \left\{ \begin{array}{c} u_{X3} \\ \theta_{Y2} \end{array} \right\} - \frac{fL^2}{12} \left\{ \begin{array}{c} 0 \\ 1 \end{array} \right\} = 0 \quad \Leftrightarrow$$

$$\left\{ \begin{array}{c} u_{X3} \\ \theta_{Y2} \end{array} \right\} = \frac{fL^3}{48Ebt} \begin{bmatrix} 4/3 & t/2 \\ t/2 & t^2/3 \end{bmatrix}^{-1} \left\{ \begin{array}{c} 0 \\ 1 \end{array} \right\} = \frac{fL^3}{48Ebt} \frac{1}{7t^2} \begin{bmatrix} 12t^2 & -18t \\ -18t & 48 \end{bmatrix} \left\{ \begin{array}{c} 0 \\ 1 \end{array} \right\} = \frac{f}{48Eb} \left( \frac{L}{t} \right)^3 \frac{1}{7} \left\{ \begin{array}{c} -18t \\ 48 \end{array} \right\} \Rightarrow$$

$$\theta_{Y2} = \frac{1}{7} \frac{fL^3}{Eb t^3}. \quad \leftarrow$$

A plate is loaded in its plane by shear force  $F$  distributed evenly as shown in the figure. Determine the displacement at the free end. Use thin-slab mode virtual work density of the plate model and a four-node element. Material properties  $E$ ,  $\nu$ ,  $\rho$  and thickness  $t$  are constants. Assume that  $u_{Y4} = u_{Y2}$ .

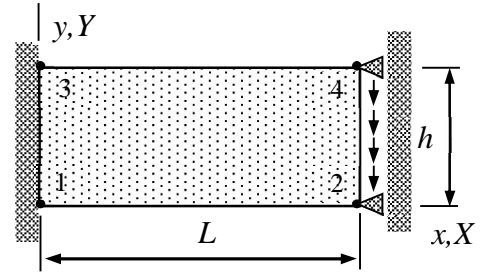

### Solution

Assuming that the material coordinate system is chosen so that the plate bending and thin slab modes decouple, virtual work density of plate is the sum of the thin-slab and plate bending mode virtual work densities. Here the bending part vanishes. The thin-slab expressions are

$$\delta w_{\Omega}^{\text{int}} = - \begin{Bmatrix} \partial \delta u / \partial x \\ \partial \delta v / \partial y \\ \partial \delta u / \partial y + \partial \delta v / \partial x \end{Bmatrix}^T t [E]_{\sigma} \begin{Bmatrix} \partial u / \partial x \\ \partial v / \partial y \\ \partial u / \partial y + \partial v / \partial x \end{Bmatrix}, \quad \delta w_{\Omega}^{\text{ext}} = \begin{Bmatrix} \delta u \\ \delta v \end{Bmatrix}^T \begin{Bmatrix} f_x \\ f_y \end{Bmatrix}$$

$$\text{and } \delta w_{\partial\Omega}^{\text{ext}} = \begin{Bmatrix} \delta u \\ \delta v \end{Bmatrix}^T \begin{Bmatrix} t_x \\ t_y \end{Bmatrix}.$$

Elasticity matrix of the plane stress case is given in the formulae collection

$$[E]_{\sigma} = \frac{E}{1-\nu^2} \begin{bmatrix} 1 & \nu & 0 \\ \nu & 1 & 0 \\ 0 & 0 & (1-\nu)/2 \end{bmatrix}.$$

Let us choose the material and structural coordinate systems to coincide. Approximations to the in-plane displacements are (the shape functions can be deduced from the figure)

$$u = \begin{Bmatrix} (1-x/L)(1-y/h) \\ (x/L)(1-y/h) \\ (1-x/L)(y/h) \\ (x/L)(y/h) \end{Bmatrix}^T \begin{Bmatrix} 0 \\ 0 \\ 0 \\ 0 \end{Bmatrix} = 0 \quad \text{and} \quad v = \begin{Bmatrix} (1-x/L)(1-y/h) \\ (x/L)(1-y/h) \\ (1-x/L)(y/h) \\ (x/L)(y/h) \end{Bmatrix}^T \begin{Bmatrix} 0 \\ u_{Y2} \\ 0 \\ u_{Y2} \end{Bmatrix} = \frac{x}{L} u_{Y2}.$$

When the approximations are substituted there, virtual work densities of internal forces and external surface forces simplify to

$$\delta w_{\Omega}^{\text{int}} = - \begin{Bmatrix} 0 \\ 0 \\ \delta u_{Y2} / L \end{Bmatrix}^T \frac{tE}{1-\nu^2} \begin{bmatrix} 1 & \nu & 0 \\ \nu & 1 & 0 \\ 0 & 0 & (1-\nu)/2 \end{bmatrix} \begin{Bmatrix} 0 \\ 0 \\ u_{Y2} / L \end{Bmatrix} = -\delta u_{Y2} \frac{1}{L^2} \frac{tE}{2(1+\nu)} u_{Y2},$$

$$\delta w_{\partial\Omega}^{\text{ext}} = \begin{Bmatrix} \delta u \\ \delta v \end{Bmatrix}^T \begin{Bmatrix} 0 \\ t_y \end{Bmatrix} = \begin{Bmatrix} 0 \\ \delta u_{Y2} x / L \end{Bmatrix}^T \begin{Bmatrix} 0 \\ -F / h \end{Bmatrix} = -\delta u_{Y2} \frac{F}{h} \frac{x}{L}.$$

Virtual work expressions are integrals of the densities over the corresponding domains

$$\delta W^{\text{int}} = \int_0^h \int_0^L \delta w_{\Omega}^{\text{int}} dx dy = -\delta u_{Y2} \frac{h}{L} \frac{tE}{2(1+\nu)} u_{Y2} \Rightarrow$$

$$\delta W^{\text{ext}} = \int_0^h \delta w_{\partial\Omega}^{\text{ext}} dy = -\delta u_{Y2} F. \quad (\text{notice that } x = L \text{ on edge 2-4})$$

Therefore

$$\delta W = \delta W^{\text{int}} + \delta W^{\text{ext}} = -\delta u_{Y2} \left( \frac{h}{L} \frac{tE}{2(1+\nu)} u_{Y2} + F \right).$$

Principle of virtual work  $\delta W = 0 \forall \delta a$  and the fundamental lemma of variation calculus give

$$\delta W = -\delta u_{Y2} \left( \frac{h}{L} \frac{tE}{2(1+\nu)} u_{Y2} + F \right) = 0 \quad \forall \delta u_{Y2} \Rightarrow \frac{h}{L} \frac{tE}{2(1+\nu)} u_{Y2} + F = 0 \quad \Leftrightarrow$$

$$u_{Y2} = -\frac{LF}{ht} \frac{2(1+\nu)}{E}. \quad \leftarrow$$

A plate is loaded in its plane by shear force  $F$  distributed evenly as shown. Determine the displacement of the free end. Use the virtual work density expressions of the thin-slab mode of the plate model and a four-node element. Material properties  $E$ ,  $\nu = 0$ ,  $\rho$  and thickness  $t$  are constants. Assume that  $u_{Y4} = u_{Y2}$  and  $u_{X4} = -u_{X2}$ . Consider the slender plate limit  $h/L \ll 1$ .

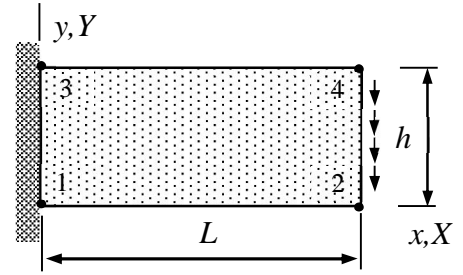

### Solution

Assuming that the material coordinate system is chosen so that the plate bending and thin slab modes decouple, virtual work density of plate is the sum of the thin-slab and plate bending modes. Here the bending part vanishes and only the thin slab part

$$\delta w_{\Omega}^{\text{int}} = - \begin{Bmatrix} \partial \delta u / \partial x \\ \partial \delta v / \partial y \\ \partial \delta u / \partial y + \partial \delta v / \partial x \end{Bmatrix}^T t [E]_{\sigma} \begin{Bmatrix} \partial u / \partial x \\ \partial v / \partial y \\ \partial u / \partial y + \partial v / \partial x \end{Bmatrix}, \quad \delta w_{\Omega}^{\text{ext}} = \begin{Bmatrix} \delta u \\ \delta v \end{Bmatrix}^T \begin{Bmatrix} f_x \\ f_y \end{Bmatrix}$$

$$\text{and } \delta w_{\partial\Omega}^{\text{ext}} = \begin{Bmatrix} \delta u \\ \delta v \end{Bmatrix}^T \begin{Bmatrix} t_x \\ t_y \end{Bmatrix}.$$

is needed. Elasticity matrix of the plane stress case is given in the formulae collection

$$[E]_{\sigma} = \frac{E}{1-\nu^2} \begin{bmatrix} 1 & \nu & 0 \\ \nu & 1 & 0 \\ 0 & 0 & (1-\nu)/2 \end{bmatrix}.$$

Let us choose the material and structural coordinate systems to coincide. Approximation to the in-plane displacement was chosen to be bilinear so that the displacement components are (the shape functions can be deduced from the figure)

$$u = \begin{Bmatrix} (1-x/L)(1-y/h) \\ (x/L)(1-y/h) \\ (1-x/L)(y/h) \\ (x/L)(y/h) \end{Bmatrix}^T \begin{Bmatrix} 0 \\ u_{X2} \\ 0 \\ -u_{X2} \end{Bmatrix} = \frac{x}{hL} (h-2y) u_{X2}, \quad \frac{\partial u}{\partial x} = \frac{h-2y}{hL} u_{X2}, \quad \frac{\partial u}{\partial y} = -2 \frac{x}{hL} u_{X2}$$

$$v = \begin{Bmatrix} (1-x/L)(1-y/h) \\ (x/L)(1-y/h) \\ (1-x/L)(y/h) \\ (x/L)(y/h) \end{Bmatrix}^T \begin{Bmatrix} 0 \\ u_{Y2} \\ 0 \\ u_{Y2} \end{Bmatrix} = \frac{x}{L} u_{Y2}, \quad \frac{\partial v}{\partial x} = \frac{1}{L} u_{Y2}, \quad \text{and} \quad \frac{\partial v}{\partial y} = 0.$$

When the approximation is substituted there, virtual work densities of internal forces and external surface forces simplify to ( $\nu = 0$ )

$$\delta w_{\Omega}^{\text{int}} = - \left\{ \begin{array}{c} \frac{h-2y}{hL} \delta u_{X2} \\ 0 \\ -2 \frac{x}{hL} \delta u_{X2} + \frac{1}{L} \delta u_{Y2} \end{array} \right\}^T tE \begin{bmatrix} 1 & 0 & 0 \\ 0 & 1 & 0 \\ 0 & 0 & 1/2 \end{bmatrix} \left\{ \begin{array}{c} \frac{h-2y}{hL} u_{X2} \\ 0 \\ -2 \frac{x}{hL} u_{X2} + \frac{1}{L} u_{Y2} \end{array} \right\} \Leftrightarrow$$

$$\delta w_{\Omega}^{\text{int}} = - \left\{ \begin{array}{c} \delta u_{X2} \\ \delta u_{Y2} \end{array} \right\}^T \frac{tE}{L^2} \begin{bmatrix} \left(\frac{h-2y}{h}\right)^2 + 2\left(\frac{x}{h}\right)^2 & -\frac{x}{h} \\ -\frac{x}{h} & \frac{1}{2} \end{bmatrix} \left\{ \begin{array}{c} u_{X2} \\ u_{Y2} \end{array} \right\}.$$

$$\delta w_{\partial\Omega}^{\text{ext}} = \left\{ \begin{array}{c} \delta u \\ \delta v \end{array} \right\}^T \left\{ \begin{array}{c} 0 \\ t_y \end{array} \right\} = \left\{ \begin{array}{c} 0 \\ \delta u_{Y2} x / L \end{array} \right\}^T \left\{ \begin{array}{c} 0 \\ -F / h \end{array} \right\} = -\delta u_{Y2} \frac{F}{h} \frac{x}{L}.$$

Virtual work expressions are integrals of the density over the corresponding domains

$$\delta W^{\text{int}} = \int_0^h \int_0^L \delta w_{\Omega}^{\text{int}} dx dy = - \left\{ \begin{array}{c} \delta u_{X2} \\ \delta u_{Y2} \end{array} \right\}^T \frac{tEL}{h} \begin{bmatrix} \frac{7}{3} \frac{h^2}{L^2} + \frac{2}{3} & -\frac{1}{2} \frac{h}{L} \\ -\frac{1}{2} \frac{h}{L} & \frac{1}{2} \frac{h^2}{L^2} \end{bmatrix} \left\{ \begin{array}{c} u_{X2} \\ u_{Y2} \end{array} \right\},$$

$$\delta W^{\text{ext}} = \int_0^h \delta w_{\partial\Omega}^{\text{ext}} dy = -\delta u_{Y2} F = - \left\{ \begin{array}{c} \delta \theta_{Z2} \\ \delta u_{Y2} \end{array} \right\}^T \left\{ \begin{array}{c} 0 \\ F \end{array} \right\}.$$

Therefore with  $h \ll L$  (so that  $h^2 \ll L^2$  in the 1-1 term of the matrix)

$$\delta W = \delta W^{\text{int}} + \delta W^{\text{ext}} = - \left\{ \begin{array}{c} \delta u_{X2} \\ \delta u_{Y2} \end{array} \right\}^T \left( tE \begin{bmatrix} \frac{2}{3} \frac{L}{h} & -\frac{1}{2} \\ -\frac{1}{2} & \frac{1}{2} \frac{h}{L} \end{bmatrix} \left\{ \begin{array}{c} u_{X2} \\ u_{Y2} \end{array} \right\} + \left\{ \begin{array}{c} 0 \\ F \end{array} \right\} \right).$$

Principle of virtual work  $\delta W = 0 \forall \delta a$  and the fundamental lemma of variation calculus give

$$\left\{ \begin{array}{c} u_{X2} \\ u_{Y2} \end{array} \right\} = -\frac{F}{tE} \begin{bmatrix} \frac{2}{3} \frac{L}{h} & -\frac{1}{2} \\ -\frac{1}{2} & \frac{1}{2} \frac{h}{L} \end{bmatrix}^{-1} \left\{ \begin{array}{c} 0 \\ 1 \end{array} \right\} = -12 \frac{F}{tE} \begin{bmatrix} \frac{1}{2} \frac{h}{L} & \frac{1}{2} \\ \frac{1}{2} & \frac{2}{3} \frac{L}{h} \end{bmatrix} \left\{ \begin{array}{c} 0 \\ 1 \end{array} \right\} = -12 \frac{F}{tE} \left\{ \begin{array}{c} \frac{1}{2} \\ \frac{2}{3} \frac{L}{h} \end{array} \right\} \Leftrightarrow$$

$$u_{X2} = -6 \frac{F}{tE} \quad \text{and} \quad u_{Y2} = -8 \frac{FL}{tEh}. \quad \leftarrow$$

Consider the plate strip shown loaded by its own weight. Thickness, length and width of the plate are  $t$ ,  $L$ , and  $H$ , respectively. Density  $\rho$ , Young's modulus  $E$ , and Poisson's ratio  $\nu$  are constants. Find an approximation to the transverse displacement  $w$  of the plate using series  $w = a_0(1 - x/L)(x/L)$  (just one term of a series) in which  $a_0$  is an unknown parameter.

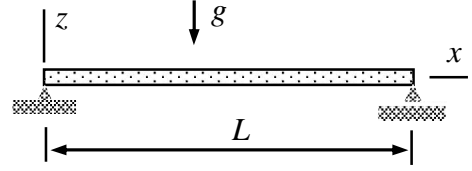

### Solution

Assuming that the material coordinate system is chosen so that the plate bending and thin slab modes decouple, virtual work densities of the Kirchhoff plate model are given by

$$\delta w_{\Omega}^{\text{int}} = - \begin{Bmatrix} \partial^2 \delta w / \partial x^2 \\ \partial^2 \delta w / \partial y^2 \\ 2\partial^2 \delta w / \partial x \partial y \end{Bmatrix}^T \frac{t^3}{12} [E]_{\sigma} \begin{Bmatrix} \partial^2 w / \partial x^2 \\ \partial^2 w / \partial y^2 \\ 2\partial^2 w / \partial x \partial y \end{Bmatrix} \quad \text{and} \quad \delta w_{\Omega}^{\text{ext}} = \delta w f_z.$$

in which the elasticity matrix of plane stress

$$[E]_{\sigma} = \frac{E}{1-\nu^2} \begin{bmatrix} 1 & \nu & 0 \\ \nu & 1 & 0 \\ 0 & 0 & (1-\nu)/2 \end{bmatrix}.$$

Approximation to the transverse displacement (notice that the polynomial shape is known and variation of displacement is through the multiplier)

$$w = a_0 \left(1 - \frac{x}{L}\right) \left(\frac{x}{L}\right) \Rightarrow \frac{\partial^2 w}{\partial x^2} = -a_0 \frac{2}{L^2}, \quad \frac{\partial^2 w}{\partial x \partial y} = 0, \quad \frac{\partial^2 w}{\partial y^2} = 0$$

$$\delta w = \delta a_0 \left(1 - \frac{x}{L}\right) \left(\frac{x}{L}\right) \Rightarrow \frac{\partial^2 \delta w}{\partial x^2} = -\delta a_0 \frac{2}{L^2}, \quad \frac{\partial^2 \delta w}{\partial x \partial y} = 0, \quad \frac{\partial^2 \delta w}{\partial y^2} = 0.$$

When the approximation is substituted there, virtual work density simplifies to

$$\delta w_{\Omega} = \delta w_{\Omega}^{\text{int}} + \delta w_{\Omega}^{\text{ext}} = -\delta a_0 \frac{2}{L^2} \frac{t^3}{12} \frac{E}{1-\nu^2} a_0 \frac{2}{L^2} - \delta a_0 \left(1 - \frac{x}{L}\right) \left(\frac{x}{L}\right) g \rho t.$$

Integration over the element gives

$$\delta W = \int_0^H \int_0^L \delta w_{\Omega} dx dy = -\delta a_0 H \left( \frac{4}{L^3} \frac{t^3 E}{12(1-\nu^2)} a_0 + \rho g t \frac{1}{6} \right).$$

Principle of virtual work  $\delta W = 0 \forall \delta a_0$  and the fundamental lemma of variation calculus give solution to the parameter

$$a_0 = -\frac{1}{2} \frac{L^4 \rho g}{t^2 E} (1 - \nu^2).$$

Therefore, approximation to the transverse displacement is given by

$$w(x, y) = -\frac{1}{2} \frac{L^4 \rho g}{t^2 E} (1 - \nu^2) \left(1 - \frac{x}{L}\right) \frac{x}{L}. \quad \leftarrow$$

A Kirchhoff plate, loaded by point force  $F$  acting at the free corner, is simply supported on two edges and free on the other two edges as shown in the figure. Determine the parameter  $a_0$  of approximation  $w(x, y) = a_0(x/L)(y/L)$  and displacement at the center point. Use the virtual work density of the Kirchhoff plate model with constant  $E$ ,  $\nu$ ,  $\rho$  and  $t$ .

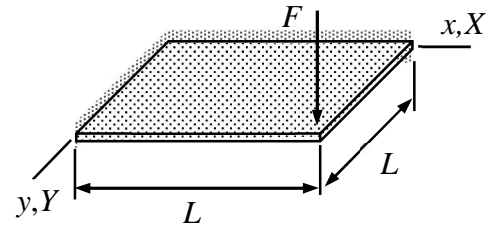

### Solution

Assuming that the material coordinate system is chosen so that the plate bending and thin slab modes decouple, it is enough to consider the virtual work densities of the bending mode only

$$\delta w_{\Omega}^{\text{int}} = - \begin{Bmatrix} \partial^2 \delta w / \partial x^2 \\ \partial^2 \delta w / \partial y^2 \\ 2\partial^2 \delta w / \partial x \partial y \end{Bmatrix}^T \frac{t^3}{12} [E]_{\sigma} \begin{Bmatrix} \partial^2 w / \partial x^2 \\ \partial^2 w / \partial y^2 \\ 2\partial^2 w / \partial x \partial y \end{Bmatrix}, \quad \delta w_{\Omega}^{\text{ext}} = \delta w f_z.$$

in which the elasticity matrix of plane stress

$$[E]_{\sigma} = \frac{E}{1-\nu^2} \begin{bmatrix} 1 & \nu & 0 \\ \nu & 1 & 0 \\ 0 & 0 & (1-\nu)/2 \end{bmatrix}.$$

In the present case, distributed force vanishes i.e.  $f_z = 0$  and the point force is taken into account by a point force element.

Approximation to the transverse displacement is chosen to be ( $a_0$  is not associated with any point but it just a parameter of the approximation)

$$w(x, y) = a_0 \frac{x}{L} \frac{y}{L} \Rightarrow \frac{\partial^2 w}{\partial x^2} = 0, \quad \frac{\partial^2 w}{\partial y^2} = 0, \quad \text{and} \quad \frac{\partial^2 w}{\partial x \partial y} = \frac{1}{L^2} a_0.$$

When the approximation is substituted there, virtual work density of internal forces simplifies to

$$\delta w_{\Omega}^{\text{int}} = - \begin{Bmatrix} \partial^2 \delta w / \partial x^2 \\ \partial^2 \delta w / \partial y^2 \\ 2\partial^2 \delta w / \partial x \partial y \end{Bmatrix}^T \frac{t^3 E}{12(1-\nu^2)} \begin{bmatrix} 1 & \nu & 0 \\ \nu & 1 & 0 \\ 0 & 0 & (1-\nu)/2 \end{bmatrix} \begin{Bmatrix} \partial^2 w / \partial x^2 \\ \partial^2 w / \partial y^2 \\ 2\partial^2 w / \partial x \partial y \end{Bmatrix} = -\delta a_0 \frac{Et^3}{6(1+\nu)} \frac{1}{L^4} a_0,$$

Virtual work expression of the plate bending element (element 1 here) is integral of the virtual work density over the domain occupied by the element

$$\delta W^1 = \int_0^L \int_0^L \delta w_{\Omega}^{\text{int}} dx dy = -\delta a_0 \frac{Et^3}{6(1+\nu)} \frac{1}{L^2} a_0.$$



Virtual work expression of the point force (element 2 here) follows from the definition of work (notice the use of virtual displacement of the point of action  $x = y = L$ )

$$\delta W^2 = \delta w(L, L)F = \delta a_0 F .$$

Principle of virtual work and the fundamental lemma of variation calculus give

$$\delta W = \delta W^1 + \delta W^2 = -\delta a_0 \left( \frac{Et^3}{6(1+\nu)} \frac{1}{L^2} a_0 - F \right) = 0 \quad \Rightarrow \quad a_0 = 6(1+\nu) \frac{FL^2}{Et^3} .$$

Displacement at the center point

$$w\left(\frac{L}{2}, \frac{L}{2}\right) = a_0 \frac{1}{4} = \frac{3}{2}(1+\nu) \frac{FL^2}{Et^3} . \quad \leftarrow$$

A simply supported plate is loaded by force  $F$  acting at the center as shown in the figure. Determine the displacement  $w(x, y)$  by using the principle of virtual work. Consider the plate bending mode only and use approximation  $w = a_0 \sin(\pi x/L) \sin(\pi y/L)$  in which  $a_0$  is a parameter. Material properties  $E, \nu, \rho$  and thickness  $t$  are constants. The shape functions of the approximation satisfy, e.g.,

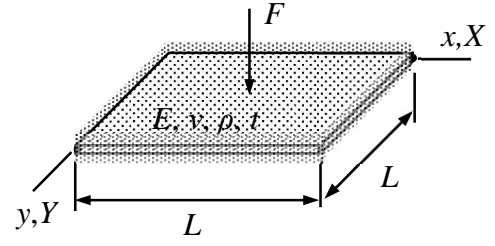

$$\int_0^L \sin(i\pi \frac{x}{L}) \sin(j\pi \frac{x}{L}) dx = \frac{L}{2} \delta_{ij}.$$

### Solution

Virtual work density of the internal forces is given by

$$\delta w_{\Omega}^{\text{int}} = - \begin{Bmatrix} \partial^2 \delta w / \partial x^2 \\ \partial^2 \delta w / \partial y^2 \\ 2\partial^2 \delta w / \partial x \partial y \end{Bmatrix}^T \frac{t^3}{12} [E]_{\sigma} \begin{Bmatrix} \partial^2 w / \partial x^2 \\ \partial^2 w / \partial y^2 \\ 2\partial^2 w / \partial x \partial y \end{Bmatrix} \quad \text{where } [E]_{\sigma} = \frac{E}{1-\nu^2} \begin{bmatrix} 1 & \nu & 0 \\ \nu & 1 & 0 \\ 0 & 0 & (1-\nu)/2 \end{bmatrix}.$$

Approximation to the transverse displacement and its derivatives

$$w = a_0 \sin(\pi \frac{x}{L}) \sin(\pi \frac{y}{L}) \Rightarrow$$

$$\frac{\partial^2 w}{\partial x^2} = \frac{\partial^2 w}{\partial y^2} = -a_0 \left(\frac{\pi}{L}\right)^2 \sin(\pi \frac{x}{L}) \sin(\pi \frac{y}{L}) \quad \text{and} \quad \frac{\partial^2 w}{\partial x \partial y} = a_0 \left(\frac{\pi}{L}\right)^2 \cos(\pi \frac{x}{L}) \cos(\pi \frac{y}{L}).$$

When the approximation is substituted there, virtual work density of internal forces simplifies to

$$\delta w_{\Omega}^{\text{int}} = - \begin{Bmatrix} \partial^2 \delta w / \partial x^2 \\ \partial^2 \delta w / \partial y^2 \\ 2\partial^2 \delta w / \partial x \partial y \end{Bmatrix}^T \frac{t^3 E}{12(1-\nu^2)} \begin{bmatrix} 1 & \nu & 0 \\ \nu & 1 & 0 \\ 0 & 0 & (1-\nu)/2 \end{bmatrix} \begin{Bmatrix} \partial^2 w / \partial x^2 \\ \partial^2 w / \partial y^2 \\ 2\partial^2 w / \partial x \partial y \end{Bmatrix} \Rightarrow$$

$$\delta w_{\Omega}^{\text{int}} = -\delta a_0 \frac{t^3 E}{12(1-\nu^2)} \left(\frac{\pi}{L}\right)^4 2 [\sin^2(\frac{\pi x}{L}) \sin^2(\frac{\pi y}{L})(1+\nu) + (1-\nu) \cos^2(\frac{\pi x}{L}) \cos^2(\frac{\pi y}{L})] a_0.$$

Virtual work expression of the plate bending element (element 1 here) is integral of the virtual work density over the domain occupied by the element

$$\delta W^1 = \int_0^L \int_0^L \delta w_{\Omega}^{\text{int}} dx dy = -\delta a_0 4 \frac{t^3 E}{12(1-\nu^2)} \left(\frac{\pi}{L}\right)^4 \left(\frac{L}{2}\right)^2 a_0.$$

Virtual work expression of the point force (element 2 here) is given by the definition of work

$$\delta W^2 = \delta w\left(\frac{L}{2}, \frac{L}{2}\right)F = \delta a_0 F.$$

Principle of virtual work and the fundamental lemma of variation calculus give

$$\delta W = \delta W^1 + \delta W^2 = -\delta a_0 \left( \frac{1}{3} \frac{t^3 E}{1-\nu^2} \left(\frac{\pi}{L}\right)^4 \left(\frac{L}{2}\right)^2 a_0 - F \right) \quad \forall \delta a_0 \quad \Leftrightarrow \quad a_0 = \frac{12}{\pi^4} \frac{FL^2}{Et^3} (1-\nu^2).$$

Displacement

$$w(x, y) = \frac{12}{\pi^4} \frac{FL^2}{Et^3} (1-\nu^2) \sin\left(\pi \frac{x}{L}\right) \sin\left(\pi \frac{y}{L}\right). \quad \leftarrow$$

A simply supported plate is loaded by its own weight as shown. Use the bending mode virtual work density of the plate model to find the displacement. Use approximation  $w = a_0(1-\xi)\xi(1-\eta)\eta$  in which  $a_0$  is the parameter to be determined and the scaled coordinates  $\xi = x/L$  and  $\eta = y/L$ . Material properties  $E$ ,  $\nu$ ,  $\rho$  and thickness  $t$  are constants.

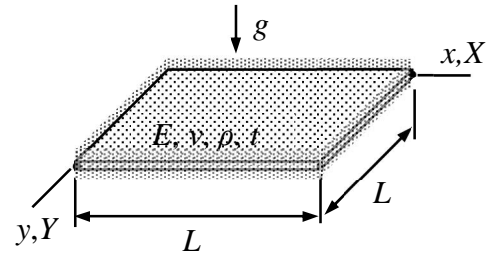

### Solution

Assuming that the material coordinate system is chosen so that the plate bending and thin slab modes decouple, it is enough to consider the virtual work densities of the bending mode only

$$\delta w_{\Omega}^{\text{int}} = - \begin{Bmatrix} \partial^2 \delta w / \partial x^2 \\ \partial^2 \delta w / \partial y^2 \\ 2\partial^2 \delta w / \partial x \partial y \end{Bmatrix}^T \frac{t^3}{12} [E]_{\sigma} \begin{Bmatrix} \partial^2 w / \partial x^2 \\ \partial^2 w / \partial y^2 \\ 2\partial^2 w / \partial x \partial y \end{Bmatrix}, \quad \delta w_{\Omega}^{\text{ext}} = \delta w f_z.$$

in which the elasticity matrix of plane stress

$$[E]_{\sigma} = \frac{E}{1-\nu^2} \begin{bmatrix} 1 & \nu & 0 \\ \nu & 1 & 0 \\ 0 & 0 & (1-\nu)/2 \end{bmatrix}.$$

The one parameter approximation to the transverse displacement gives

$$w(x, y) = a_0 \left(1 - \frac{x}{L}\right) \frac{x}{L} \left(1 - \frac{y}{L}\right) \frac{y}{L} \Rightarrow$$

$$\frac{\partial^2 w}{\partial x^2} = -a_0 \frac{2}{L^2} \left(1 - \frac{y}{L}\right) \frac{y}{L}, \quad \frac{\partial^2 w}{\partial y^2} = -a_0 \frac{2}{L^2} \left(1 - \frac{x}{L}\right) \frac{x}{L}, \quad \text{and} \quad \frac{\partial^2 w}{\partial x \partial y} = a_0 \frac{1}{L^2} \left(1 - 2\frac{x}{L}\right) \left(1 - 2\frac{y}{L}\right).$$

When the approximation is substituted there, virtual work densities of internal and external forces take the forms

$$\delta w_{\Omega}^{\text{int}} = -\delta a_0 \begin{Bmatrix} -(1-\frac{y}{L})\frac{y}{L} \\ -(1-\frac{x}{L})\frac{x}{L} \\ (1-2\frac{x}{L})(1-2\frac{y}{L}) \end{Bmatrix}^T \frac{4 t^3 E}{L^4 12 (1-\nu^2)} \begin{bmatrix} 1 & \nu & 0 \\ \nu & 1 & 0 \\ 0 & 0 & (1-\nu)/2 \end{bmatrix} \begin{Bmatrix} -(1-\frac{y}{L})\frac{y}{L} \\ -(1-\frac{x}{L})\frac{x}{L} \\ (1-2\frac{x}{L})(1-2\frac{y}{L}) \end{Bmatrix} a_0 \Leftrightarrow$$

$$\delta w_{\Omega}^{\text{int}} = -\delta a_0 \frac{4}{L^4} \frac{t^3}{12} \frac{E}{1-\nu^2} \left[ \left(1 - \frac{y}{L}\right)^2 \left(\frac{y}{L}\right)^2 + \left(1 - \frac{x}{L}\right)^2 \left(\frac{x}{L}\right)^2 + 2\nu \left(1 - \frac{y}{L}\right) \left(\frac{y}{L}\right) \left(1 - \frac{x}{L}\right) \left(\frac{x}{L}\right) + \frac{1-\nu}{2} \left(1 - 2\frac{x}{L}\right)^2 \left(1 - 2\frac{y}{L}\right)^2 \right] a_0,$$

$$\delta w_{\Omega}^{\text{ext}} = \delta w f_z = \delta a_0 \left(1 - \frac{x}{L}\right) \frac{x}{L} \left(1 - \frac{y}{L}\right) \frac{y}{L} \rho g t .$$

Virtual work expression of the plate bending element (element 1 here) is integral of the virtual work density over the domain occupied by the element

$$\delta W^{\text{int}} = \int_0^L \int_0^L \delta w_{\Omega}^{\text{int}} dx dy = -\delta a_0 \frac{1}{L^4} \frac{t^3}{3} \frac{E}{1-\nu^2} \left( \frac{L^2}{30} + \frac{L^2}{30} + 2\nu \frac{L^2}{36} + \frac{1-\nu}{2} \frac{L^2}{9} \right) a_0 \quad \Leftrightarrow$$

$$\delta W^{\text{int}} = -\delta a_0 \frac{1}{L^2} \frac{Et^3}{1-\nu^2} \frac{11}{270} a_0,$$

$$\delta W^{\text{ext}} = \int_0^L \int_0^L \delta w_{\Omega}^{\text{ext}} dx dy = \delta a_0 \frac{L^2}{36} \rho g t .$$

Therefore

$$\delta W = \delta W^{\text{int}} + \delta W^{\text{ext}} = -\delta a_0 \frac{1}{L^2} \frac{Et^3}{1-\nu^2} \frac{11}{270} a_0 + \delta a_0 \frac{L^2}{36} \rho g t \quad \Leftrightarrow$$

$$\delta W = -\delta a_0 \left( \frac{1}{L^2} \frac{Et^3}{1-\nu^2} \frac{11}{270} a_0 - \frac{L^2}{36} \rho g t \right).$$

Principle of virtual work and the fundamental lemma of variation calculus give

$$\delta W = -\delta a_0 \left( \frac{1}{L^2} \frac{Et^3}{1-\nu^2} \frac{11}{270} a_0 - \frac{L^2}{36} \rho g t \right) = 0 \quad \forall \delta a_0 \quad \Leftrightarrow$$

$$\frac{1}{L^2} \frac{Et^3}{1-\nu^2} \frac{11}{270} a_0 - \frac{L^2}{36} \rho g t = 0 \quad \Leftrightarrow \quad a_0 = \frac{15}{22} \frac{g \rho L^4}{Et^2} (1-\nu^2) .$$

Displacement

$$w(x, y) = \frac{15}{22} \frac{g \rho L^4}{Et^2} (1-\nu^2) \left(1 - \frac{x}{L}\right) \frac{x}{L} \left(1 - \frac{y}{L}\right) \frac{y}{L} . \quad \leftarrow$$

At point  $x = L/4$  and  $y = L/2$  of a 4-noded plate element there is a point moment with magnitude  $M$ . Determine the virtual work expression  $\delta W^{\text{ext}}$  of the moment for a Reissner-Mindlin plate element. Assume that nodes 1,2,4 are fixed and that the approximations to all unknown functions are bi-linear.

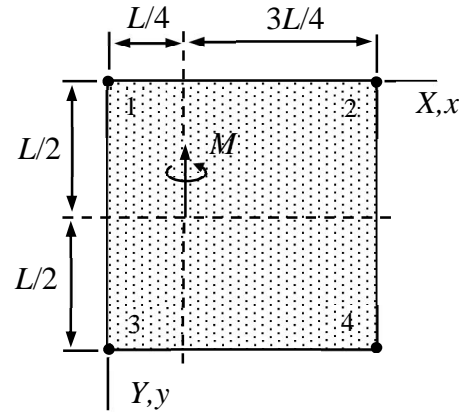

### Solution

In the present course, point forces and moment are taken into account by one node element. Virtual work expression follows from the definition “force multiplied by virtual displacement in its direction” and “point moment multiplied by the virtual rotation in its direction”.

Virtual rotation at the point of action depends on the bilinear rotation component approximation in the  $y$ -direction for

$$\delta\theta(x, y) = \begin{Bmatrix} (1-x/L)(1-y/L) \\ (x/L)(1-y/L) \\ (1-x/L)(y/L) \\ (x/L)(y/L) \end{Bmatrix}^T \begin{Bmatrix} 0 \\ 0 \\ \delta\theta_{Y3} \\ 0 \end{Bmatrix} = \left(1 - \frac{x}{L}\right) \frac{y}{L} \delta\theta_{Y3} \Rightarrow$$

$$\delta\theta\left(\frac{L}{4}, \frac{L}{2}\right) = \frac{3}{4} \frac{1}{2} \delta\theta_{Y3} = \frac{3}{8} \frac{1}{2} \delta\theta_{Y3}.$$

Virtual work expression from the definition “point moment multiplied by the virtual rotation in its direction”

$$\delta W^{\text{ext}} = \delta\theta\left(\frac{L}{4}, \frac{L}{2}\right)(-M) = -\frac{3}{8} M \delta\theta_{Y3}. \quad \leftarrow$$