

Lecture 4, HSE - Planning and Execution of a Biorefinery Investment Project

PROCESS INDUSTRIES DIVISION



Agenda

- Holistic view of health and safety
 - Regulations, laws, guides and standards
- HSE in projects
- Risk analyses

Who Am I?

Tuomas Melanen, M.Sc. (Tech.)

HSE Technology Manager

Vantaa Office, Finland

tuomas.melanen@afry.com

SPECIALITY

Chemical safety permitting (Seveso) and legislation

Risk analyses (i.a. HAZOP, HAZID, SIL)

Hazardous areas (ATEX)

BACKGROUND

M.Sc. (Tech.), Chemical Engineering

2015- Pöyry Finland Oy, Afry Finland Oy

2015-2019 Process Engineering

2010- HSE Engineering

Holistic view of Health and safety



Regulations

- ATEX Directives 2014/34/EU and 1992/92/EC
- Pressure Equipment Directive (PED) 2014/68/EU
- Machinery Directive 2006/42/EC
- Use of Work Equipment Directive 2009/104/Low Voltage Directive 2014/35/EU
- SEVESO III Directive 2012/18/EU
- The Classification, Labelling and Packaging (CLP) Regulation (Regulation (EC) 1272/2008)
- Registration, Evaluation, Authorization and Restriction of Chemicals (REACH) (Regulation (EC) 1907/2006)
- The Biocidal Products Regulation (Regulation (EU) 528/2012)
- Etc.

HSE legislation in Finland

- Chemical safety legislation; Act on the Safe Handling of Dangerous Chemicals and Explosives 390/2005 and Chemical safety Decrees, i.a. 685/2015, 856/2012, 686/2015 and 858/2012
- Government Decree 551/2009 for Safety in the handling of natural gas
- Finnish national ATEX Decrees 1439/2016 and 576/2003
- Decree 848/2017 of the Ministry of the Environment on Fire safety of buildings (848/2017)
- Pressure equipment Directive (PED) 2014/68/EU, Finnish national PED Law 1144/2016 and Decrees 1548/2016, 1550/2016 and 1549/2016
- Act on the Conformity of Certain Technical Devices to Relevant Requirements 1016/2004, and Finnish National Machinery Safety Decree 400/2008 and Government Decree on the Safe Use and Inspection of Work Equipment 403/2008
- All applicable environmental laws and regulations

Standards and guidelines

- Tukes guides
 - Dangerous chemicals in industry
 - Guide on good practices at chemical facilities
 - Safety report
 - Plant location
 - Etc.
- The Finnish Standards Association (SFS)
 - Tank storage of flammable and combustible liquids and associated handling facilities, SFS 3350
 - Combustible Chemicals Production Plant, SFS 3353
 - Explosive atmospheres SFS 60079
 - Safety of Machinery SFS-EN ISO 14122
 - Etc.

HSE in projects

PROCESS INDUSTRIES

Industrial safety consulting core services



COMPLIANCE & PERMITTING

- Chemicals
- Machinery
- Pressure equipment
- Environment
- Safety audits, HSE DD
- Explosion protection (ATEX)



SAFETY MANAGEMENT

- Safety Management Systems
- Safety training
- Functional safety
- HSE Excellence (OE)
- Human factors
- Safety visualisation



RISK ANALYSES

- Process Hazard Analysis, PHA
- Machinery safety risk assessment
- Environmental risk assessment
- Occupational safety evaluation
- Food safety, HACCP
- Consequence analysis & modelling
- RAMS engineering



PROJECT HSE SERVICES

- Project Safety Management (Safety Stepwise)
- HSE Design review
- Construction risk analysis
- Site HSE management and supervising
- Safety training

Project HSE services – Safety is our key priority

Safety has many levels that need to be taken into consideration to ensure optimal operational safety of an industrial plant.

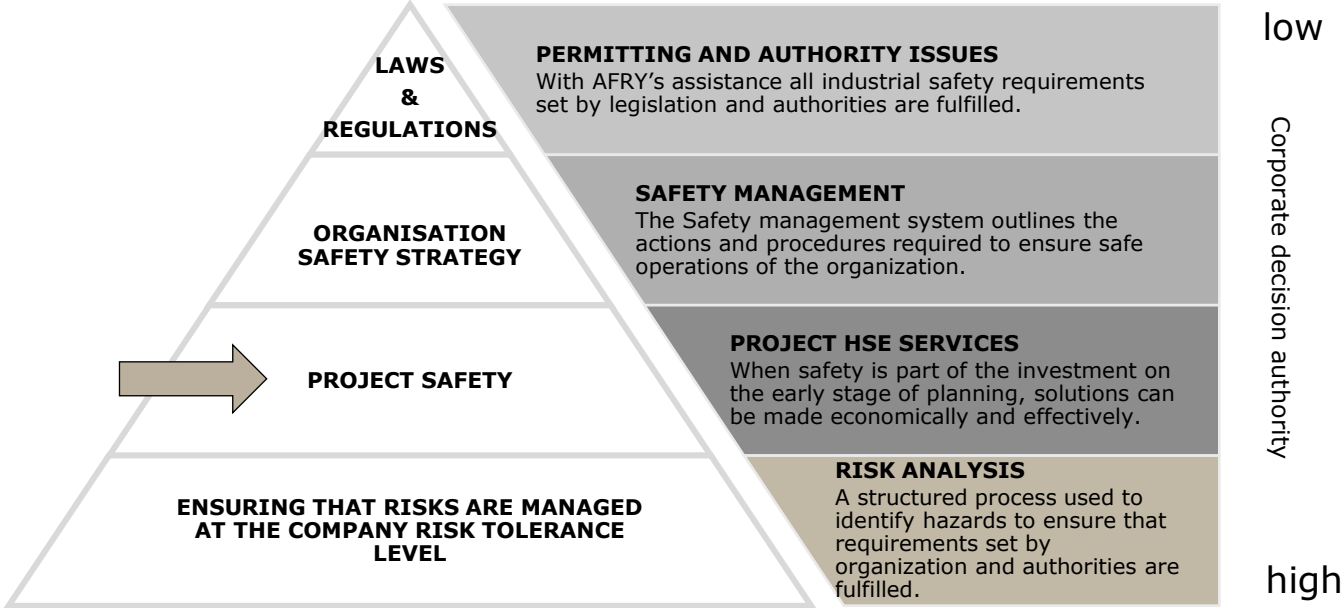

Safety Stepwise™ – Safety within a life cycle of project

1. Step	2. Step	3. Step	4. Step	5. Step	6. Step
Pre-engineering	Basic Engineering	Detailed Engineering	Construction and Erection	Commissioning and Start-Up	Production
<p>Master action list</p> <ul style="list-style-type: none"> • HSE criteria/Project specific requirements • Connections to authorities • Principles of Inherent safety • Chemicals and materials • Plant location • Plant structure • Emergency facilities • Empirical accident data in similar plants <ul style="list-style-type: none"> -Internal -External 	<ul style="list-style-type: none"> • Master action list (update) • Preliminary risk analysis. <ul style="list-style-type: none"> -Hazardous scenario analysis -Potential problem analysis -Checklists -Etc. • Layout risk analysis <ul style="list-style-type: none"> -Safety distances (Eg. Standards and Consequence analysis) -Emergency exits/escape routes -Rescue team access -Maintenance -logistics • Fire risk analysis • Pre-ATEX study • Preliminary definition of safety automation • Safety requirements for suppliers • Safety guidelines for engineering • Fire protection classification • Permitting plan 	<ul style="list-style-type: none"> • Master action list (update) • Detailed risk analysis <ul style="list-style-type: none"> -HAZOP -Human error analysis -What-if -analysis -Failure mode and effect analysis • ATEX Study <ul style="list-style-type: none"> -Explosion protection document -Hazardous area classification -Equipment classification (Ex) • Design of safety automation <ul style="list-style-type: none"> -SIL-assessment (risk graph, LOPA, etc. -Safety plan • Fire protection of structures • Process isolation procedures • 3D safety review 	<ul style="list-style-type: none"> • Master action list (update) • Legal safety document • Site HSE plan • HSE organisation and job descriptions • Safety guidelines for contractors • Contractor's commitment for safety and contractors HSE plan • Verification of risk reduction measures • Change management • Operation and maintenance manuals (preparation) • Safety and operation training • Rescue plan • Site safety procedures <ul style="list-style-type: none"> -Safety instructions -Job safety analysis -Toolbox talks -Personnel equipment -Training -Reporting & investigation -Safety communication -Audits -Work permits, etc • Conformity check • Mechanical completion check 	<ul style="list-style-type: none"> • Master action list (update) • Review of legislation and regulations • Review of safety requirements and practices <ul style="list-style-type: none"> -Pre-start activities -Operation and maintenance manuals (check) -Acceptance of final documentation -Work permits after mechanical completion • Emergency preparedness 	<ul style="list-style-type: none"> • Master action list (update) • Acceptance of final documentation • Process safety file check • Learning from practical experience • Archiving • Continual improvement
Documentation collected phase by phase into the project's process safety file / system					

Industrial example

Industrial safety within a life cycle of project

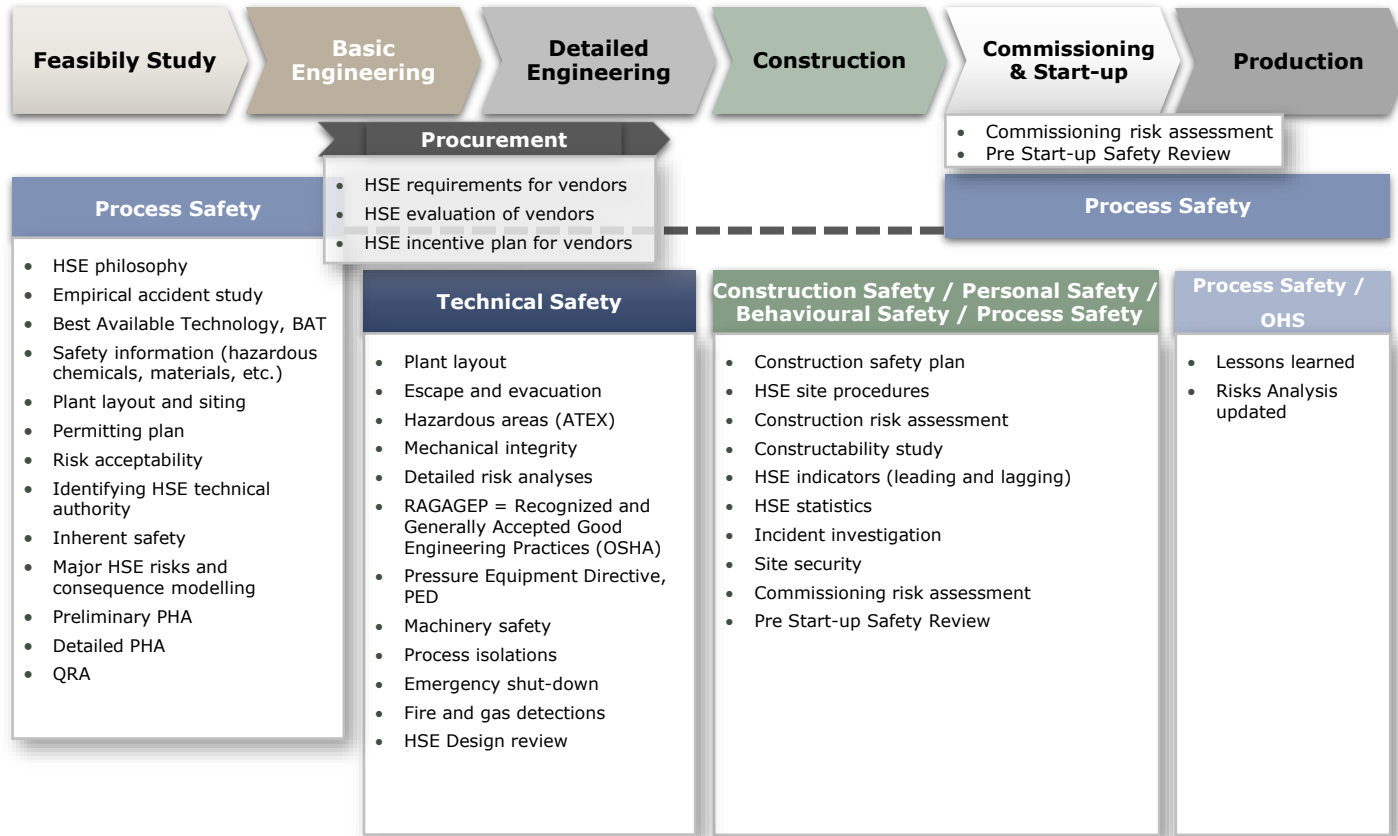

Safety Stepwise™ – Benefits of risk management throughout the lifecycle of a plant

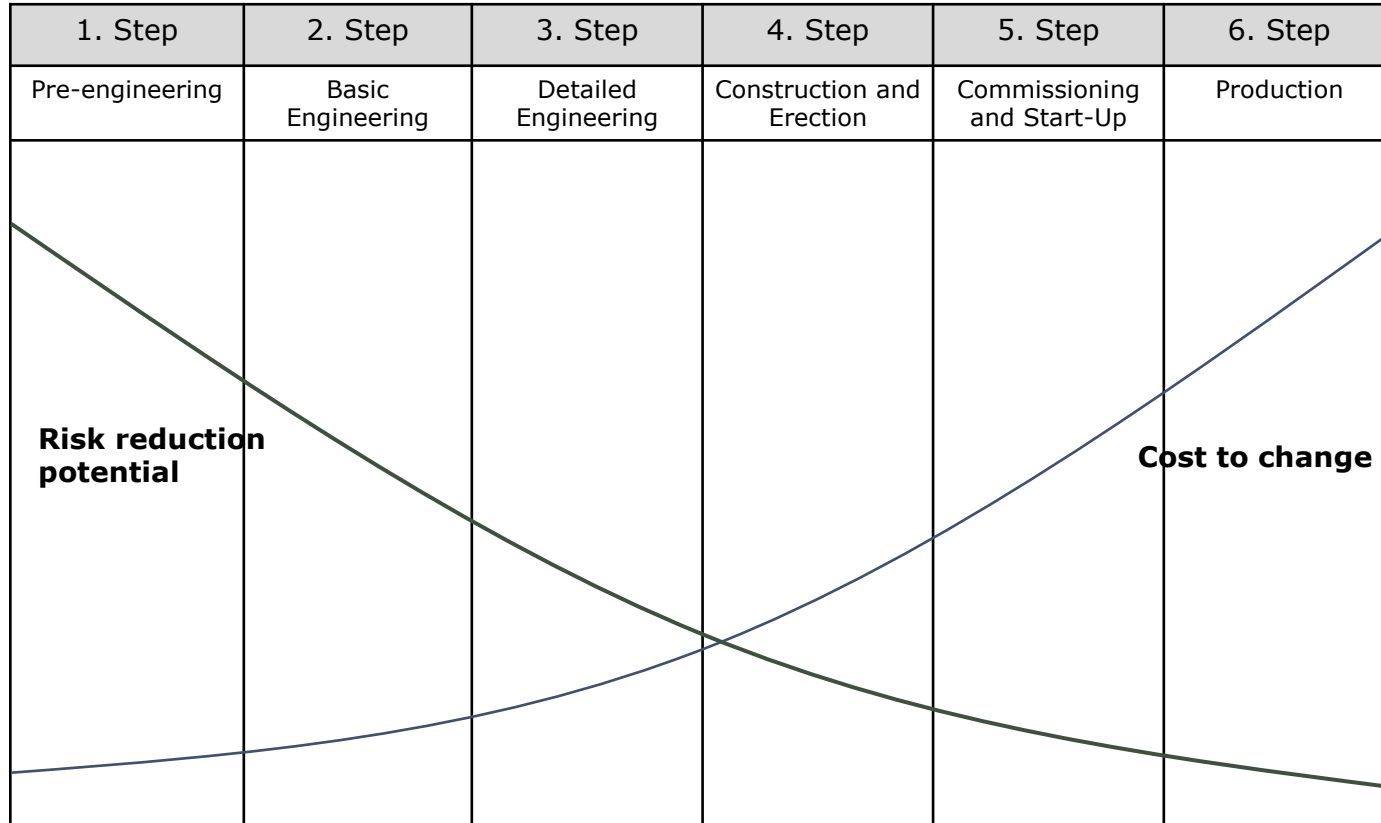

HSE in projects – management elements

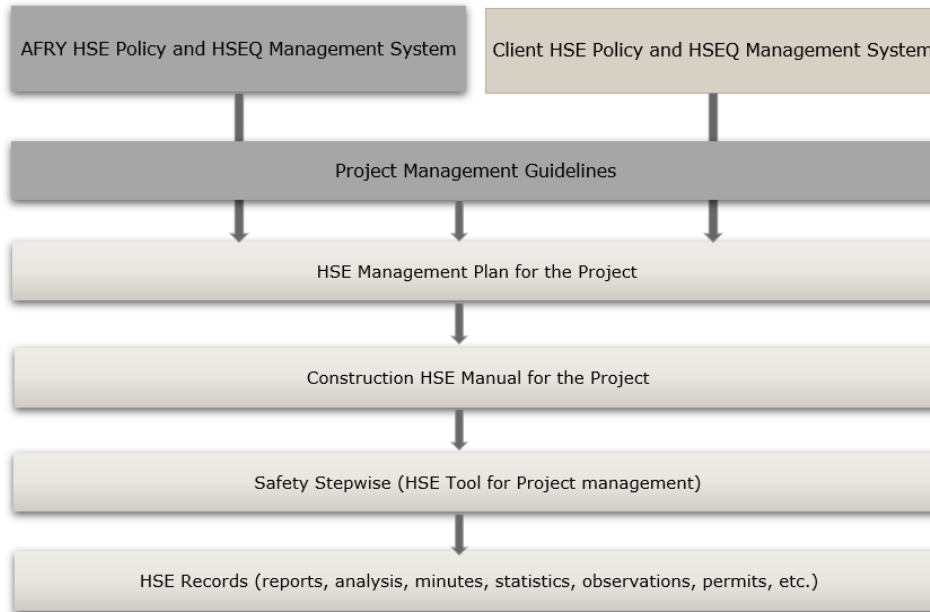

Responsibilities

- Project Manager has the ultimate responsibility of ensuring that all HSE requirements are correctly implemented.

Project Manager

- To ensure that all legal documents have been prepared
- To ensure that the owner has nominated the Safety Coordinator
- To nominate the key persons for the project
- To ensure that the HSE Management Program has been implemented and launched in the project
- To plan the HSE audit schedule and arrange HSE auditor for the project
- To ensure that the HSE requirements are met in the engineering and execution phases

HSE Lead Engineer

- To prepare HSE Management Plant for the project (HSE Management Plan describes overall HSE requirements needed in project's engineering and construction phases.)
- To lead and report HSE Design Review
- To support engineering team with HSE related issues
- To lead process safety risk assessment

Discipline leads

- To ensure that discipline specific HSE issues are taken into consideration
- To co-operate with the other disciplines concerning HSE issues



Risk analyses



Risk analyses

Effective way to

- Identify risks
- Provide safe solutions
- Awareness of process safety and machinery safety related risks not high and correlation and probability of accidents and threats not clear

Risk analysis with several methods

- HAZID, HAZSCAN, HAZOP, SIL (Safety Integrity Level), HEA
- Machinery Safety Risk Analysis
- Consequence analyses and modelling

Benefits

- Risks identified and safe solutions provided
- Information for decision makers
- Requirements set by legislation and authorities fulfilled



Process Risk Analysis – Hierarchical Approach

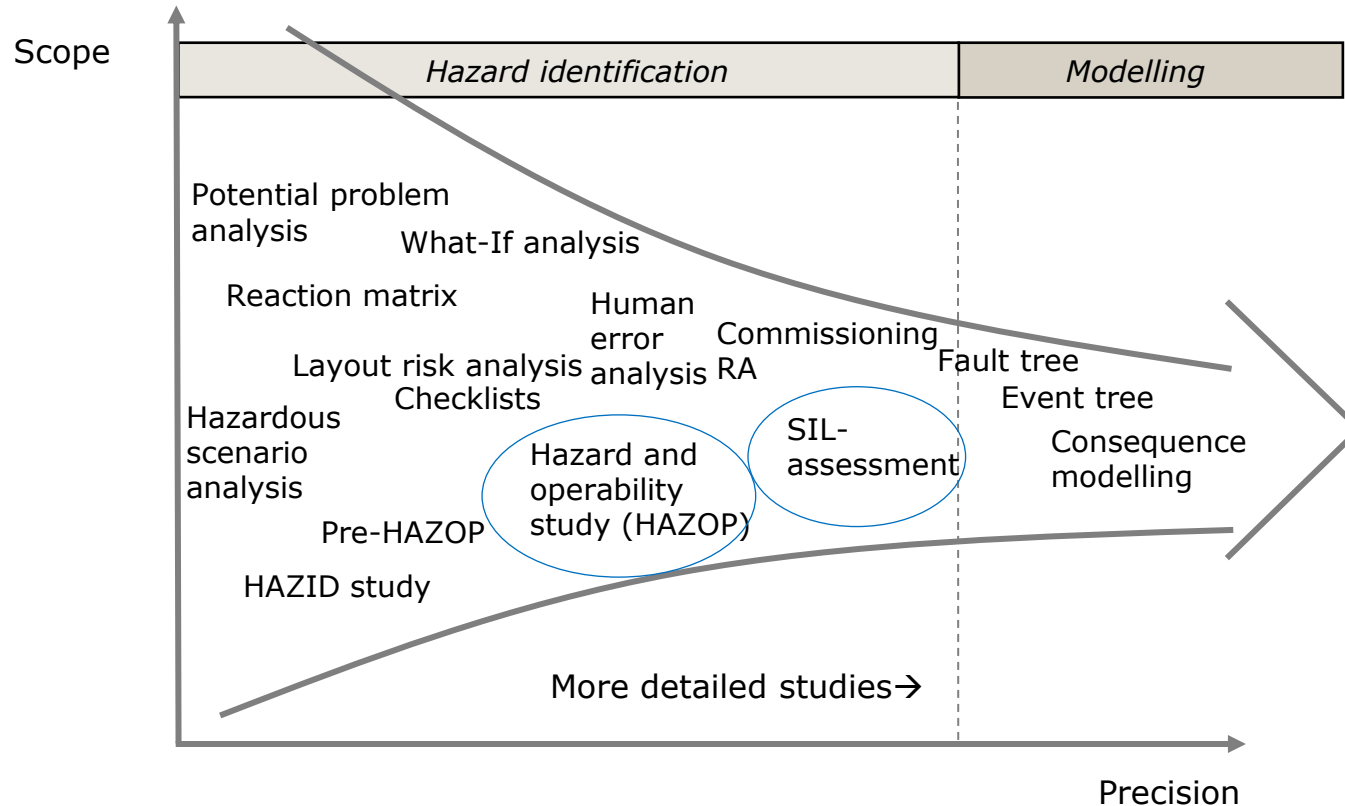

HAZOP (Hazard and Operability Study)

- HAZOP is a standardized risk analysis method (IEC 61882: 2016) that is widely used in the process industry. A method generally accepted by the authorities and insurers.
- A systematic method based on the PI diagrams of the process and the division into smaller entities to be processed - **nodes**.

1. Each node is examined individually and any **process deviations (cause)** that occur in them are identified by means of preselected deviations.
2. The identified incidents - **scenarios** - are described as accurately as possible until the final outcome and are classified using a risk matrix.
3. Existing **safeguards** related to the scenario are identified and their adequacy is assessed
4. If necessary, recommendation proposals are recorded to improve the situation

Design Conditions/Parameters:

Deviation	Causes	Consequences	Risk Matrix			Safeguards	Risk Matrix2			Recommendations (HAZOP)					Comment	
			S	L	RR		S	L	RR	Recommendations (HAZOP)	Responsibility	Status	Execution	Due Date		
1. High Flow	1. Failure of frequency controller in main conveyor	1. Blockage on biomass feeding point	S1	L3	0	1. Blockage detector in biomass belt conveyor 2. Interlock between the conveyors upstream	S1	L1	0	41. Consider adding 6 blockage detectors before main conveyor, in dropping chutes	nn.					

HAZOP Scope

Scope	Note
Physical scope	See List of PIDs
The study covers: <ul style="list-style-type: none">• Human incidents• Environmental incidents• Asset damages and reputation, if needed• Operational issues	Focus on process and operational safety
The study does not cover: <ul style="list-style-type: none">• Occupational health and safety in general (personal safety)• Mechanical failures in generally• Product quality problems• Security issues	It is assumed that the plant is designed and constructed according to industry standards and good practices

HAZOP Analysis

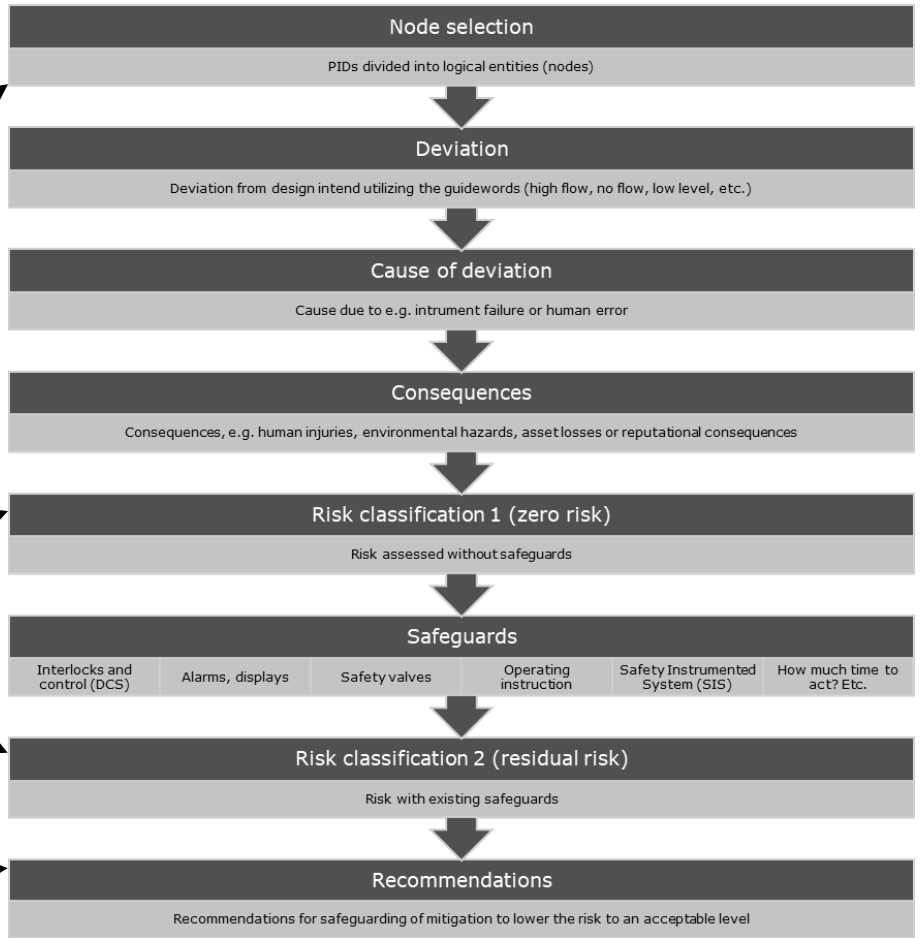
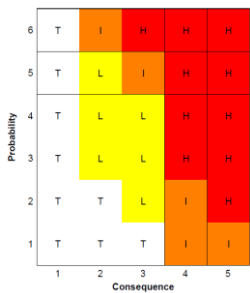
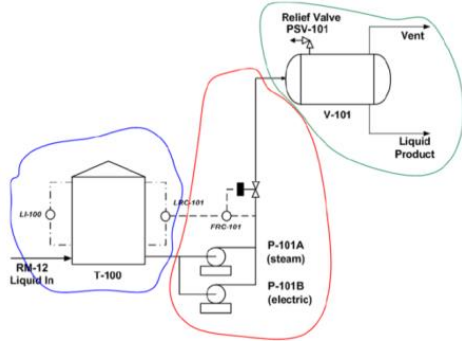

Node: 26. HHE - Main Fuel Feeding System
 Drawing: abc1, abc2, abc3.
 Design Conditions/Parameters:

Deviation	Causes	Consequences	Risk Matrix1		Safeguards	Risk Matrix2		Recommendations (HAZOP)						
			S	LR		S	LR	Recommendations (HAZOP)	Responsibility	Status	Execution	Due Date	Comment	
1. High Flow	1. Failure of frequency controller in main conveyor	1. Blockage on biomass feeding point	S1	L3	1. Blockage detector in biomass belt conveyor? Interlocks between the conveyors upstream	S1	L1	41. Consider adding 6 blockage detectors before main conveyor, in dropping chutes	hh.					

Risk matrix example

- The risk is a combination of a severity of consequence and a probability of the event.
- Qualitative analysis and classification of probability is performed according to standard IEC 60300-3-9 which is widely applied in process industry.
- The standard is developed for the risk assessment of technological systems

Risk Ranking	Description
H	High risk. Not acceptable - Immediate actions needed.
I	Intermediate risk. Not acceptable - Actions needed within a reasonable time period.
L	Low risk: Acceptable - Follow-up recommended.
T	Trivial risk. Acceptable - No actions needed.

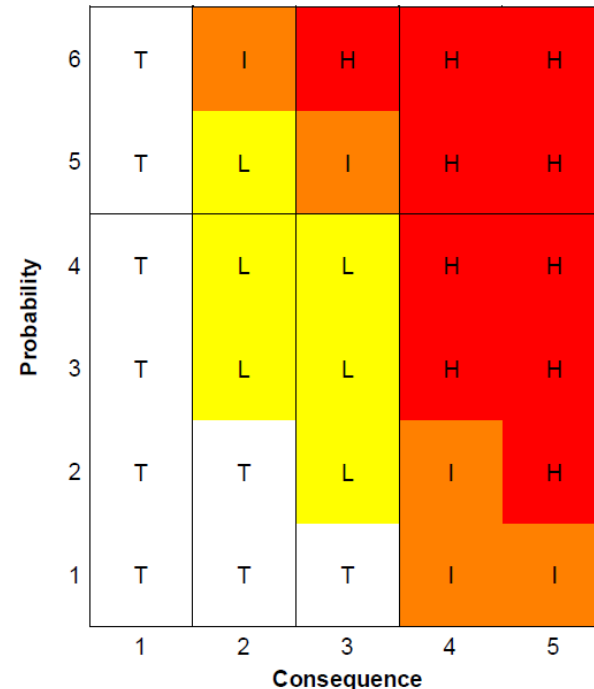

Risk matrix example

Consequence	Description
1	Negligible People: First aid injury Assets: No system damage. Environment: No environmental impacts.
2	Minor People: Minor injury, minor occupational illness Assets: Minor system damage. Environment: Minor local environmental impacts inside plant area (small leakage can be easily cleaned up).
3	Severe: People: Severe injury (Lost-time injury), severe occupational illness Assets: Significant damage to the plant or system. Environment: Hazardous emissions low (temporary local deterioration of water quality, damage to animal and plant species and their habitats inside the plant area)
4	Major People: Permanent disability or one fatality Assets: Extensive damage to the plant or system. Environment: Severe local environmental impacts (local fish deaths, damage to animal and plant species and their habitats outside the plant area)
5	Catastrophic People: Many fatalities. Assets: Virtually complete loss of plant or system. Environment: Long-term and severe environmental impacts (fish deaths, groundwater pollution, serious damage to animal and plant species and their habitats outside the plant area)

Probability	Description
1	Practically never. Highly Improbable: $< 10^{-6}$
2	Not once in the industrial field. Improbable: $10^{-4} - 10^{-6}$
3	Not once during the life cycle of the plant. Remote: $10^{-2} - 10^{-4}$
4	Once during the life cycle of the plant. Occasional: $10^{-1} - 10^{-2}$
5	More than once during the life cycle of the plant. Probable: $1 - 10^{-1}$
6	More than once in a year. Frequent: > 1

Layer of Protection Analysis (LOPA)

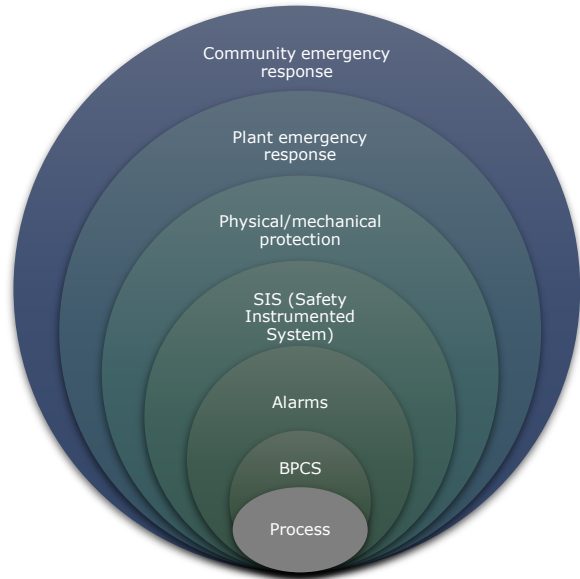

Identification of protection layers that prevent or mitigate hazard

- Total amount of risk reduction
- Analyzing of additional risk reduction
- If SIF (Safety instrumented function), determination of appropriate SIL for SIF



Hazard identification study (HAZID) Methodology

- The main purpose of the HAZID is to identify situations capable of leading major incidents having health, safety and environmental (HSE) impacts and asset losses and is carried out by a team.
- HAZID is one of the preliminary risk analysis methods
 - The results of preliminary risk assessment are critical in **recognizing the hazardous processes and significant risks.**
 - to **prioritize the identified risks** using their likelihood of occurring and their corresponding consequence.
- The scope and focus of further detailed risk studies, for example the hazard and operability study (HAZOP) or consequence analyses, will be defined on the basis of the HAZID.
- Implementation of a HAZID study is done using PHA-Pro software. The software delivers a comprehensive safety management in teamwork oriented analysis.
 - All information becomes recorded reliably ensuring easy and transparent data management.



HAZID guidewords

1. Materials and substances (raw materials, chemicals, additives, products, dusts, utilities (electricity, water, steam, nitrogen, pressure-/instrument air))
2. Equipment and machines (malfunctions)
3. Normal operation and working (human errors, dangerous work phases (lifting, confined spaces, ATEX), working alone, physical factors (noise, vibration, temp., lighting))
4. Maintenance (interlocking, isolations, work areas, hazardous work (hot work, confined space, electrical work), deficiencies in maintenance)
5. Processes (malfunctions, instrumentation, fail safe positions, DCS, hazardous reactions (liquids, gases), dusting, safety basins, materials, temperature, pressure)
6. Layout and surrounding facilities (locations, walkways, emergency routes, distances)
7. Environment (relief valves/ventilation openings (emissions to air), emissions to water, waste, extreme weather conditions)
8. Traffic (cars, heavy traffic, work vehicles and pedestrians)
9. Safety systems/solutions (SIS, earthing, safety markings (chemicals, pipelines, noise, Ex, routes), insulations, emergency showers/ eye wash stations, emergency kits, fire extinguishing system, fire water, emergency lighting, ventilation, UPS, working platforms, surface coating/patterns, emergency exits)
10. Accidents (fire (pool/jet), explosions, BLEVE, dispersion of hazardous chemicals, domino effects, heat, smoke, reactions, consequence analysis, escaping)



HAZSCAN (Hazardous scenario Analysis) Methodology

Sub-processes

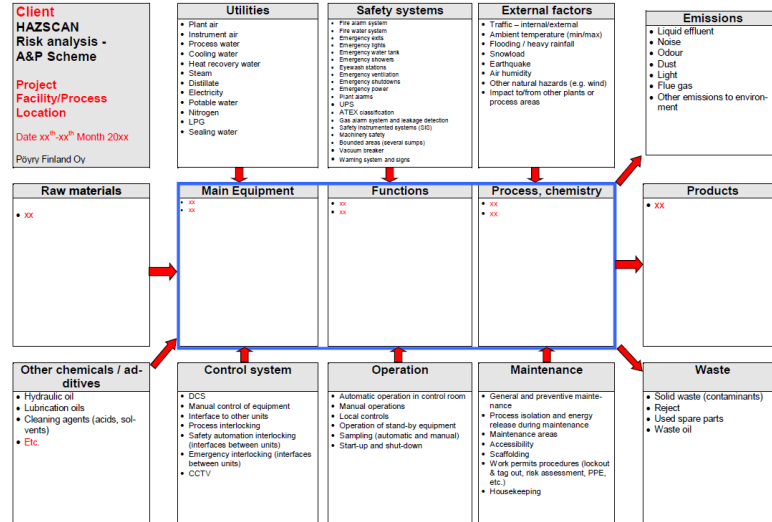
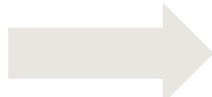
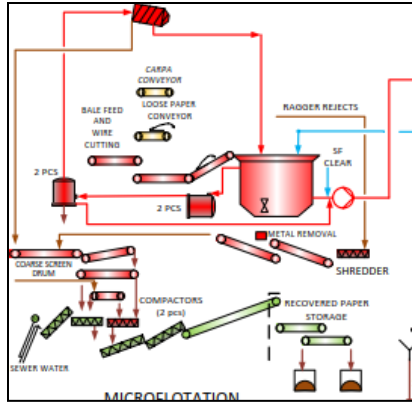

Other risk analysis

- Consequence Analysis
 - Fire and heat radiation
 - Overpressure wave
 - Acute Exposure Guideline Levels (AEGLs)
- Hazardous areas (ATEX)
 - Explosion hazard identification and assessment
 - Ignition hazard identification and assessment
- Human error analyses (HEA)



Questions?

And if any questions later (material or career choices) feel free to contact AFRY's HSE team via Lassi Laumola

Making Future