

1) We are given:

3-phase

$$f = 60\text{Hz}$$

$$n = 1746\text{rpm}$$

a)

$$n = \frac{60f}{p} \Rightarrow p = \frac{60f}{n}$$

$$p = \frac{60 \cdot 60}{1746} = 2.06$$

Since number of poles has to be an integer it is the closest integer which is 2.

b)

$$\text{Synchronous speed : } n_s = \frac{60f}{p} = \frac{60 \cdot 60}{2} = 1800\text{rpm}$$

$$s = \frac{n_s - n}{n_s} = \frac{1800 - 1746}{1800} = 0.03$$

c)

$$f_r = s \cdot f_s = 0.03 \cdot 60 = 1.8\text{Hz}$$

d) Speed of rotor field:

$$n_{rf} = s \cdot n_s = 0.03 \cdot 1800 = 54\text{rpm}$$

Speed of rotor field with respect to stator structure :

$$54 + 1746 = 1800\text{rpm}$$

Speed of rotor field with respect to stator field :

$$1800 - 1800 = 0\text{rpm}$$

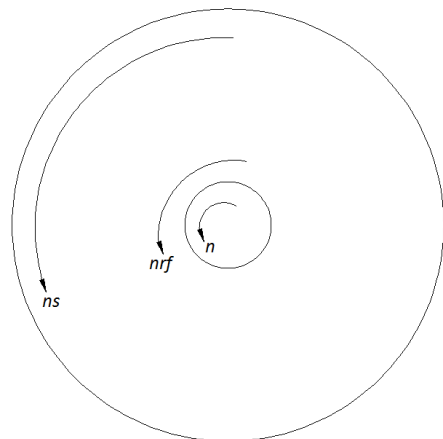

2) We are given:

3-phase

$$f = 60\text{Hz}$$

$$p = 3$$

$$s = 0.03$$

a)

$$n_s = \frac{60f}{p} = \frac{60 \cdot 60}{3} = 1200\text{rpm}$$

$$s = \frac{n_s - n}{n_s} \Rightarrow n = n_s(1 - s)$$

$$n = 1200(1 - 0.03)$$

$$n = 1164\text{rpm}$$

The rotor has same direction as rotating field as  $0 < s < 1$  it is in motoring mode.

b)

$$f_2 = sf_1 = 0.03 \cdot 60 = 1.8\text{Hz}$$

c)

$$n_s = 1200\text{rpm}$$

d)

$$n_{ag} = 1200\text{rpm}$$

e)

$$n_{rf} = s \cdot n_s = 0.03 \cdot 1200 = 36\text{rpm (w.r.t. rotor structure)}$$

$$n_{rfs1} = n + n_{rf} = 1164 + 36 = 1200\text{rpm (w.r.t. stator structure)}$$

$$n_{rfs1} = n_s - n_{rfs1} = 0 \text{ (w.r.t. stator field)}$$

3) We are given:

3-phase

$$f = 60\text{Hz}$$

$$p = 3$$

$$s = -0.03$$

a)

$$n = (1-s)n_s = (1+0.03)1200 = 1236\text{rpm}$$

b)

$$f_2 = sf_1 = -1.8\text{Hz}$$

c)

$$n_{sf} = n_s = 1200\text{rpm}$$

d)

$$n_{ag} = n_s = 1200\text{rpm}$$

e)

i)  $n_{rf} = s \cdot n_s = -36\text{rpm}$

ii)  $n_s + n_{rf} = 1236 - 36 = 1200\text{rpm}$

iii)  $1200 - 1200 = 0\text{rpm}$

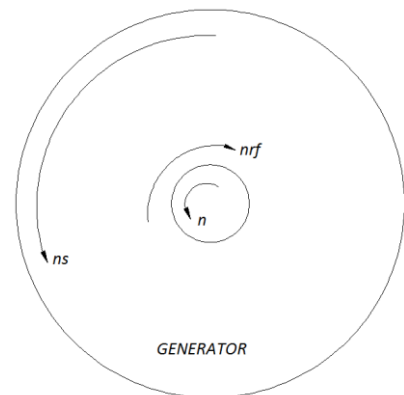

4) We are given:

3-phase

$$f = 60\text{Hz}$$

$$p = 3$$

$$s = 1.5$$

a)

$$n = (1 - s)n_s = (1 - 1.5)1200 = -600\text{rpm}$$

b)

$$f_2 = sf_1 = 90\text{Hz}$$

c)

$$n_{sf} = n_s = 1200\text{rpm}$$

d)

$$n_{ag} = n_s = 1200\text{rpm}$$

e)

i)  $n_{rf} = s \cdot n_s = 1.5 \cdot 1200 = 1800\text{rpm}$

ii)  $n_s + n_{rf} = -600 + 1800 = 1200\text{rpm}$

iii)  $1200 - 1200 = 0\text{rpm}$

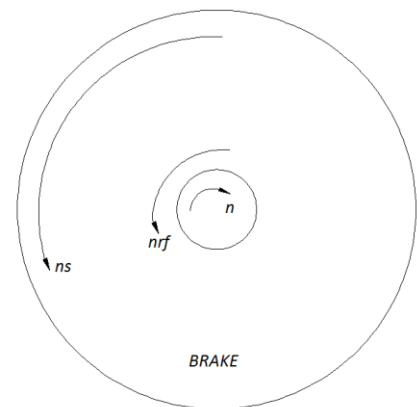

5) We are given:

$$U_{ls} = 208V$$

$$p = 3$$

$$f = 60Hz$$

$$\frac{N_1}{N_2} = 0.5$$

a)  $n = 1140rpm$

i)

$$s = \frac{n_s - n}{n_s} \Rightarrow n_s = \frac{60f}{p} = \frac{60 \cdot 60}{3} = 1200rpm$$

$$s = \frac{1200 - 1140}{1200} = 0.05$$

ii)

$$U_{ps} = \frac{U_{ls}}{\sqrt{3}} = 120V$$

$$U_{p2} = \frac{N_2}{N_1} \cdot U_{ps} = \frac{0.5}{1} 120 = 60V \text{ (for } s = 1)$$

$$\text{for } s = 0.05 \Rightarrow U_{pr} = s \cdot U_{p2} = 3V$$

$$f_2 = s \cdot f_s = 0.05 \cdot 60 = 3Hz$$

iii)

$$n_{rf} = s \cdot n_{sf} = 0.05 \cdot 1200 = 60rpm$$

$$n_{rsf} = n_s + n_{rf} = 1140 + 60 = 1200rpm$$

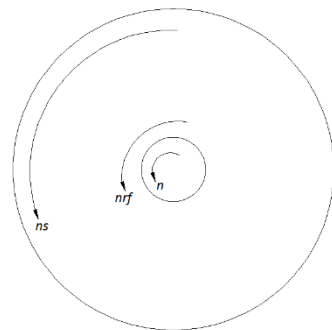

b)

$$U_{lr} = 208V$$

$$n = 1164rpm$$

$$n_{sf} = 1200 - 1164 = 36rpm$$

$$s = \frac{n_s - n}{n_s} = \frac{1200 - 1164}{1200} = 0.03$$

$$U_{pr} = \frac{208}{\sqrt{3}} = 120V$$

$$U_{ps} = s \cdot \frac{N_1}{N_2} \cdot U_{pr} = 0.03 \cdot \frac{1}{0.5} \cdot 120 = 7.2V$$

$$f_1 = s \cdot f_2 = 0.03 \cdot 60 = 1.8Hz$$

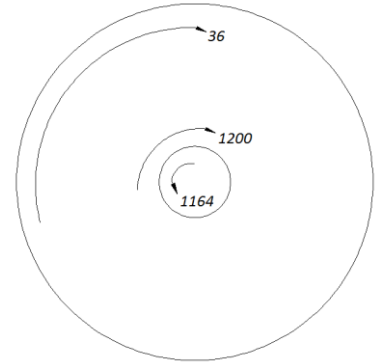

6)

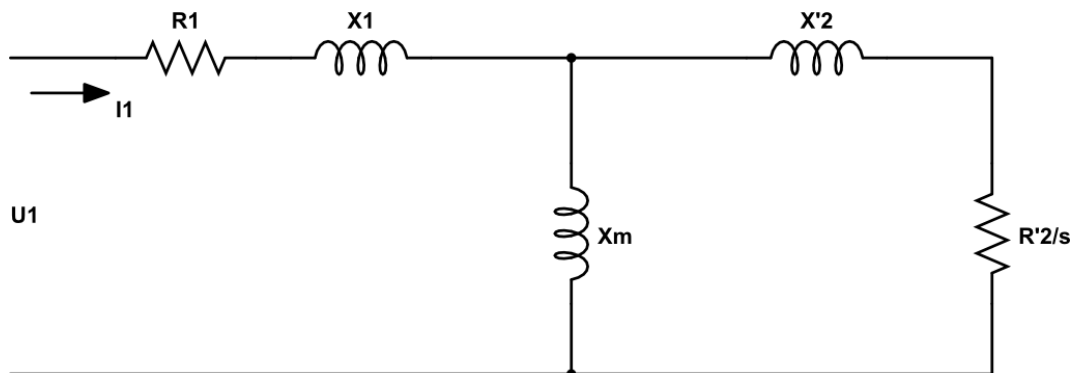

a)

$$R_1 = \frac{R_{ldc}}{2} = \frac{0.152}{2} = 0.076\Omega$$

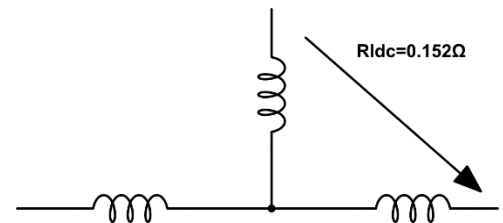

► No load test:  $s = 0$ ,  $U_0 = 460V$ ,  $f = 60Hz$ ,  $I_0 = 40A$ ,  $P_0 = 4.2kW$

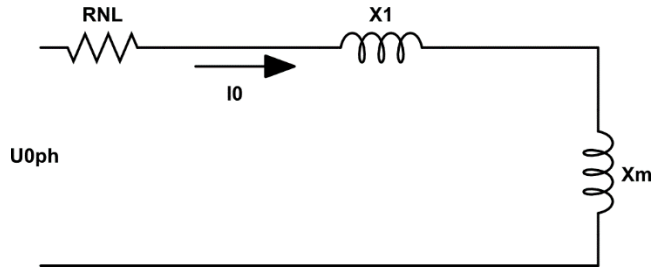

$$U_{0ph} = \frac{460}{\sqrt{3}} = 265.6V$$

$$Z_{NL} = \frac{U_{0ph}}{I_0} = \frac{265.6}{40} = 6.64\Omega$$

$$P_0 = 3R_{NL}I_0^2 \Rightarrow R_{NL} = \frac{P_0}{3I_0^2} = \frac{4200}{3 \cdot 40^2} = 0.875\Omega$$

$$X_{NL} = X_1 + X_m = \sqrt{X_{NL}^2 - R_{NL}^2} = 6.58\Omega$$

► Blocked rotor test:  $s = 1$ ,  $U_{br} = 100V$ ,  $f = 60Hz$ ,  $I_{br} = 140A$ ,  $P_{br} = 8kW$

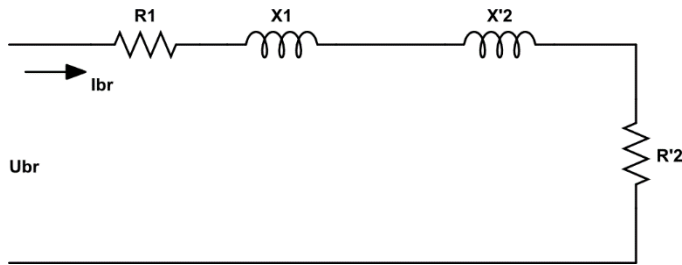

$$U_{br} = \frac{100}{\sqrt{3}} = 57.7V$$

$$Z_{br} = \frac{U_{br}}{I_{br}} = \frac{57.7}{140} = 0.41\Omega$$

$$P_{br} = 3(R_1 + R_2')I_{br}^2 \Rightarrow R_1 + R_2' = \frac{P_{br}}{3I_{br}^2} = 0.136\Omega$$

$$R_2' = 0.136 - 0.076 = 0.06\Omega$$

$$X_1 + X_2' = \sqrt{Z_{br}^2 - (R_1 + R_2')} = 0.39\Omega$$

$$X_1 = X_2' = \frac{X_1 + X_2'}{2} = 0.19\Omega$$

$$X_m = X_{NL} - X_1 = 6.3\Omega$$

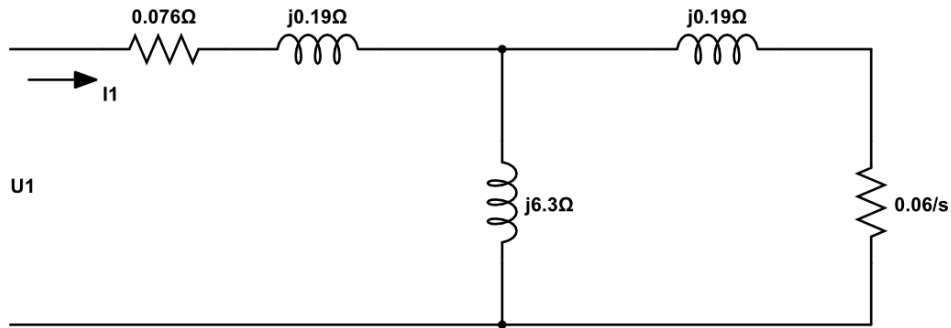

b) We are given:

$$U = 460V, f = 60Hz, n = 873rpm, 2p = 8$$

Solution:

$$n_s = \frac{60f}{p} = \frac{60 \cdot 60}{4} = 900rpm$$

$$s = \frac{n_s - n}{n_s} = \frac{900 - 873}{900} = 0.03$$

$$\frac{R_2'}{0.03} = 2\Omega$$

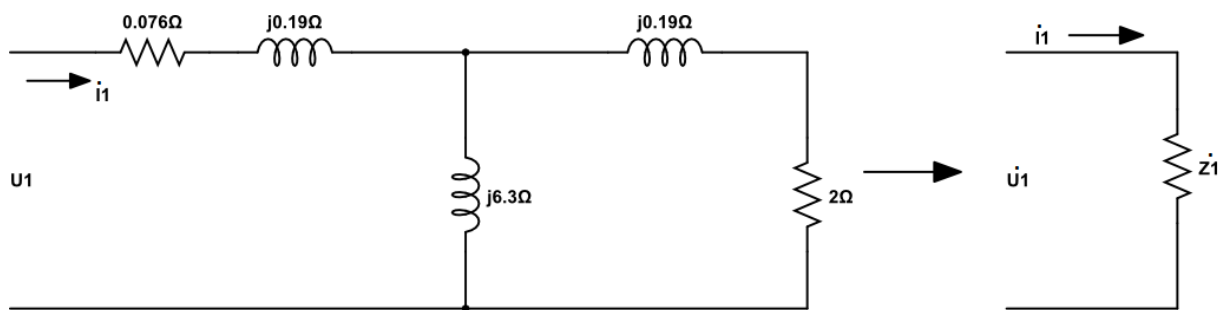

$$\dot{Z}_1 = 0.076 + 0.19j + \frac{(2 + 0.19j) \cdot 6.3j}{2 + 0.19j + 6.3j} = 1.8 + 0.9j = 2 \angle 0.47 \text{ rad } \Omega$$

$$\dot{I}_1 = \frac{U_1}{\dot{Z}_1} = \frac{265.6}{2 \angle 0.47} = 132.8 \angle -0.47 \text{ rad A}$$

Input Power :

$$P_{in} = 3U_1 I_1 \cos \theta = 3 \cdot 265.6 \cdot 132.8 \cdot \cos(0.47 \text{ rad})$$

$$P_{in} = 94341.3W$$



Airgap Power :

$$P_{ag} = 3 \cdot (I_2')^2 \cdot \frac{R_2'}{s}$$

Thevenin equivalent circuit :

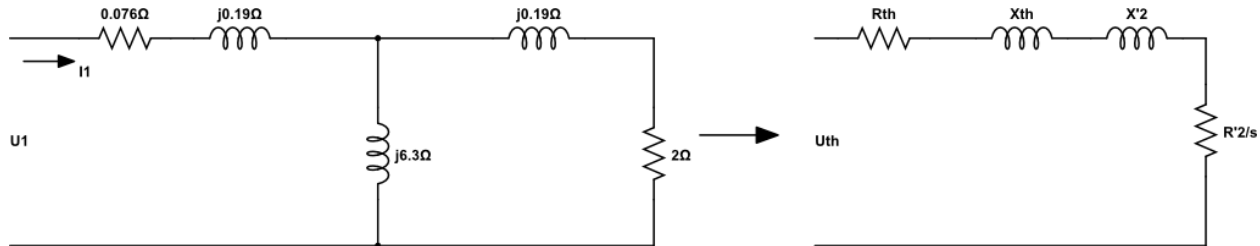

$$U_{th} = \frac{265.6 \cdot j6.3}{0.076 + 6.3j + 0.19j} = 248.7V$$

$$Z_{th} = \frac{6.3j \cdot (0.076 + 0.19j)}{6.3j + 0.076 + 0.19j} = 0.0717 + 0.185j = 0.198 \angle 1.2 \text{rad}$$

$$R_{th} = 0.0717\Omega, \quad X_{th} = 0.185\Omega$$

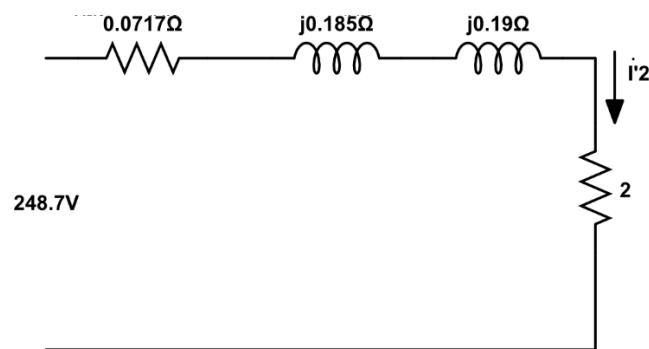

$$\dot{i}_2 = \frac{248.7}{2 + 0.0717 + j0.185 + j0.19} = 116.44 - j21.35 = 118.38 \angle -0.18 \text{rad A}$$

► Airgap power:

$$P_{ag} = 3 \cdot 118.38^2 \cdot 2 = 84083W$$

► Rotor copper loss:

$$P_2 = s \cdot P_{ag} = 0.03 \cdot 84083 = 2522.5W$$

► Mechanical power:

$$P_{mech} = (1-s) \cdot P_{ag} = (1-0.03) \cdot 84083 = 81560.5 \text{ W}$$

► Rotational losses:

$$P_{rot} = P_0 - 3I_0^2 R_1 = 4200 - 3 \cdot 40^2 \cdot 0.076 = 3835.2 \text{ W}$$

► Output power:

$$P_{out} = P_{mech} - P_{rot} = 81560.5 - 3835.2 = 77725.3 \text{ W}$$

► Efficiency:

$$\eta = \frac{P_{out}}{P_{in}} = \frac{77725.3}{94341.3} = 0.824$$

7) SM:  $p_{SM} = 2$

IM:  $p_{IM} = 3$

a)

$$n_s = \frac{60f}{p_{SM}} = \frac{60 \cdot 60}{2} = 1800 \text{ rpm} = n_{IM-actual}$$

$$n_{s(IM)} = \frac{60f}{p_{IM}} = \frac{60 \cdot 60}{3} = 1200 \text{ rpm}$$

$$s = \frac{n_{s(IM)} - n_{IM-actual}}{n_{s(IM)}} = \frac{1200 - 1800}{1200} = -0.5$$

$$f_{load} = s \cdot f = 30 \text{ Hz}$$

$$P_2 = s \cdot P_{ag} \Rightarrow P_{ag} = \frac{P_2}{s} = \frac{1}{-0.5} = -2 \text{ pu}$$

$$P_{mech} = (1-s)P_{ag} = -3 \text{ pu}$$

$$P_{in-SM} = 3 \text{ pu (Input of SM)}$$

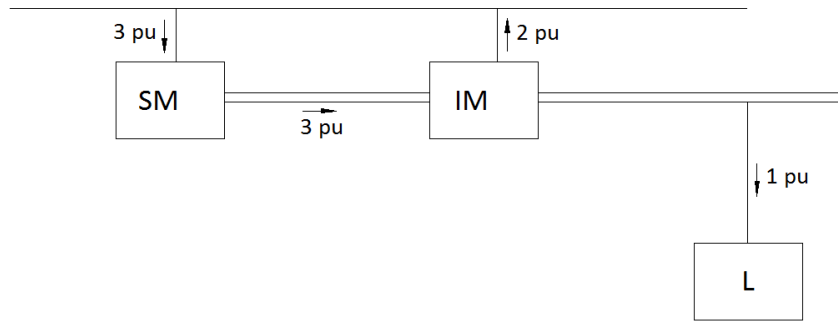

b)

$$n_s = 1800 \text{ rpm} = n_{IM-actual}$$

$$n_{s(IM)} = -1200 \text{ rpm (reversed)}$$

$$s = \frac{n_{s(IM)} - n_{IM-actual}}{n_{s(IM)}} = \frac{-1200 - 1800}{-1200} = 2.5$$

$$f_2 = s \cdot f_1 = 2.5 \cdot 60 = 150 \text{ Hz}$$

$$P_{ag} = \frac{P_2}{s} = \frac{1}{2.5} = 0.4 \text{ pu}$$

$$P_{mech} = (1-s)P_{ag} = (1-2.5) \cdot 0.4 = -0.6 \text{ pu}$$

$$P_{in-SM} = 0.6 \text{ pu}$$

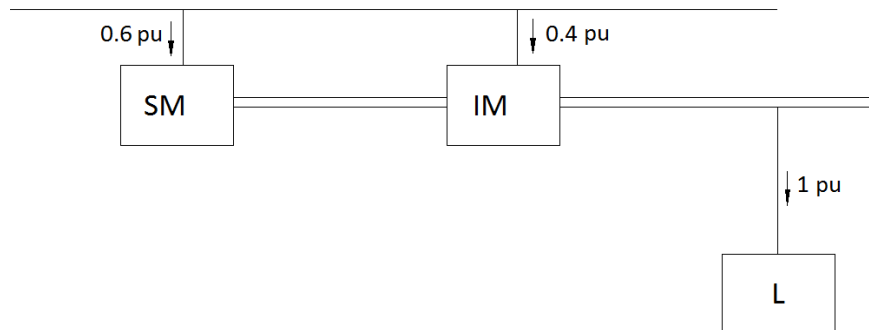

8)

a)

$$p = 4$$

$$n_s = \frac{60f}{p} = \frac{60 \cdot 60}{4} = 900 \text{rpm}$$

$$n = (1-s) \cdot n_s = 922.5 \text{rpm}$$

b)

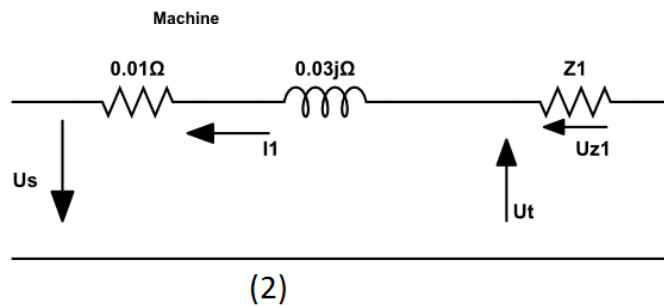
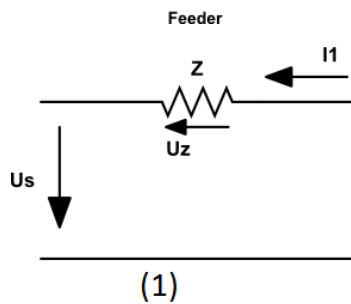
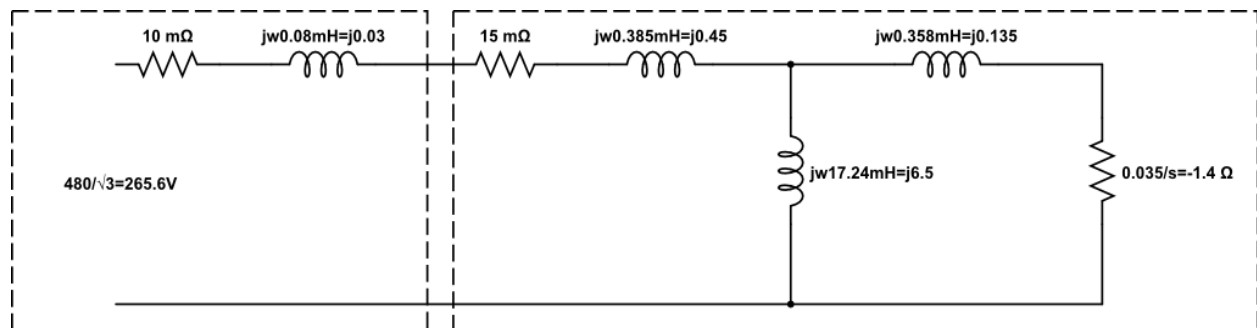

► From circuit (1) :

$$Z = 0.01 + 0.03j + 0.015 + 0.0145j + \frac{6.5j(-1.4 + 0.135j)}{6.5j - 1.4 + 0.135j}$$

$$Z = 1.39 \angle 155^\circ$$

$$Z_1 = Z - (0.01 + 0.03j) = -1.27 + 0.418j = 1.337 \angle 161.78^\circ$$

$$U_z + U_s = 0 \Rightarrow U_z = -U_s$$

$$Z \cdot I_1 = -U_s \Rightarrow I_1 = -\frac{U_s}{Z}$$

$$I_1 = -\frac{265.6}{1.39\angle 155^\circ} = 173 + 81j = 191\angle 25^\circ \text{ A}$$

► From circuit (2) :

$$U_t = -U_{z_1} = U_s + (0.01 + 0.03j)I_1$$

$$U_t = 265.6 + (0.01 + 0.03j) \cdot (173 + 81j)$$

$$U_t = 264.9 + 6j = 265\angle 1.3^\circ \text{ V}$$

c)

$$\varphi = 25^\circ \Rightarrow \cos \varphi = 0.906$$

$$P_{out} = 3U_s I_1 \cos \varphi = 3 \cdot 265.6 \cdot 191 \cdot \cos(25^\circ)$$

$$P_{out} = 137.9 \text{ kW}$$

d)

$$P = 3RI^2$$

$$P_{feed} = 3 \cdot 0.01 \cdot 191^2 = 1064 \text{ W}$$

$$P_{cus} = 3 \cdot 0.015 \cdot 191^2 = 1642 \text{ W}$$

$$P_{ag} = P_{out} + P_{feed} + P_{cus} = 140.6 \text{ kW}$$

$$P_{mech} = (1 - s)P_{ag} = 144.1 \text{ kW}$$

$$P_{in} = P_{mech} + P_{rot} = 144.1 + 3 = 147.1 \text{ kW}$$

$$\eta = \frac{P_{out}}{P_{in}} = \frac{137.9}{147.1} = 0.939$$

9)

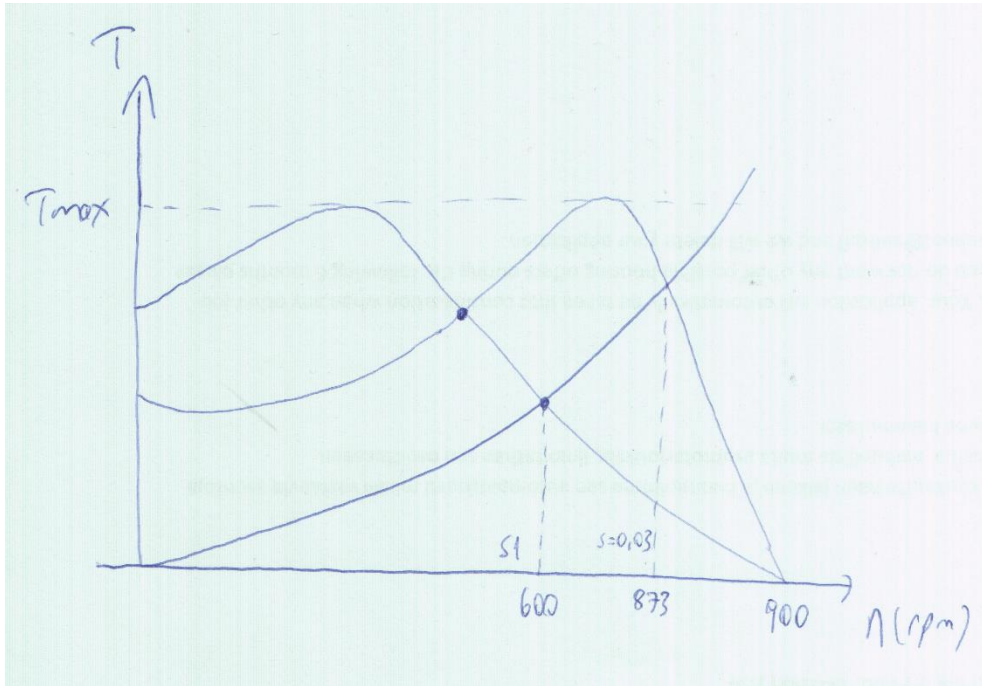

$$p = 4$$

$$s = 0.03$$

$$R'_{20} = 0.02\Omega$$

$$n_s = \frac{60f}{p} = \frac{60 \cdot 60}{4} = 900 \text{rpm}$$

$$n_0 = (1 - s_0)n_s = 873 \text{rpm}$$

$$\omega = 2\pi \frac{n}{60} = 2\pi \frac{873}{60} = 91.42 \text{rad/s}$$

$$\omega_s = 2\pi \frac{n}{60} = 2\pi \frac{900}{60} = 94.25 \text{rad/s}$$

$$T = \frac{3}{\omega_s} \frac{U_{th}^2}{\left(R_{th} + \frac{R'_2}{s}\right)^2 + (X_{th} + X'_2)^2} \cdot \frac{R'_2}{s}$$

$$s \rightarrow 0 \Rightarrow R_{th} + \frac{R'_2}{s} \gg X_{th} + X'_2 \text{ and } \frac{R'_2}{s} \gg R_{th}$$

$$\Rightarrow T = \frac{3}{w_s} \frac{U_{th}^2}{R_2} s$$

$$T_0 = \frac{3}{w_s} \frac{U_{th}^2}{R_{20}} s_0, \quad T_1 = \frac{3}{w_s} \frac{U_{th}^2}{R_{21}} s_1 \quad \text{where } R_{21}' = R_{ext} + R_{20}'$$

$$\frac{T_0}{T_1} = \frac{s_0}{s_1} \frac{R_{21}'}{R_{20}'} \Rightarrow R_{21}' = \frac{T_0}{T_1} \frac{s_1}{s_0} R_{20}' \quad (1)$$

$$s_1 = \frac{n_s - n_1}{n_s} = \frac{900 - 600}{900} = 0.33$$

$$T_0 = K \cdot n_0^2 \quad (\text{This relation is given in problem})$$

$$\Rightarrow K = \frac{T_0}{n_0^2}$$

$$T_1 = K \cdot n_1^2 = \frac{T_0}{n_0^2} \cdot n_1^2 \Rightarrow \frac{T_0}{T_1} = \frac{n_0^2}{n_1^2} \quad (\text{substitute in (1)})$$

$$R_{21}' = \frac{n_0^2}{n_1^2} \frac{s_1}{s_0} R_{20}' = \frac{873^2}{600^2} \frac{0.33}{0.03} 0.02 = 0.47 \Omega$$

$$R_{ext} = R_{21}' - R_{20}' = 0.47 - 0.02 = 0.45 \Omega$$

10)

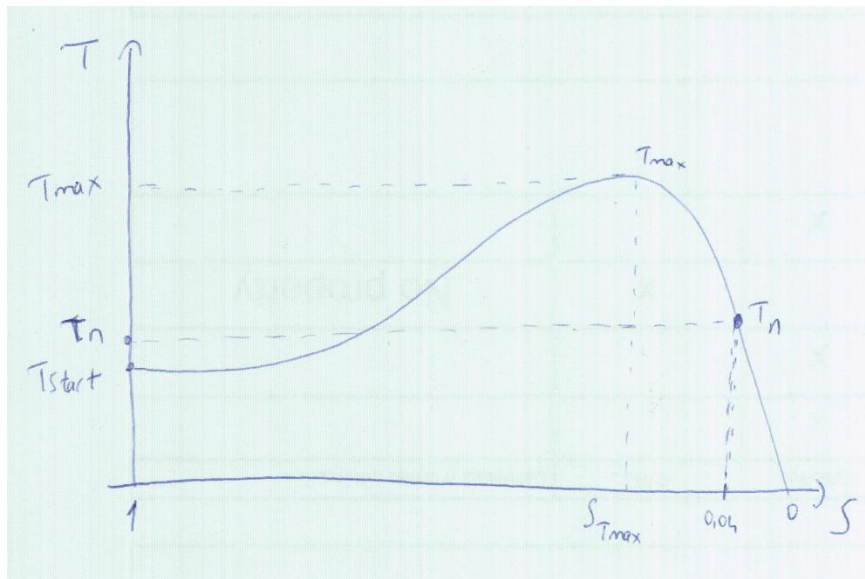

$$2p = 4$$

$$U = 460V$$

$$f = 60Hz$$

$$s_n = 0.04$$

$$T_{\max} = 2.5 pu$$

a)

$$\frac{T_{\max}}{T_n} = \frac{s_{T_{\max}}^2 + s_n^2}{2 \cdot s_{T_{\max}} \cdot s_n}$$

$$\Rightarrow s_{T_{\max 1,2}} = \frac{2s_n \frac{T_{\max}}{T_n} \pm \sqrt{\left(2s_n \frac{T_{\max}}{T_n}\right)^2 - 4s_n^2}}{2}$$

$$s_{T_{\max 1}} = 0.0085$$

$$\boxed{s_{T_{\max 2}} = 0.1917}$$

$$n_s = \frac{60f}{p} = \frac{60 \cdot 60}{2} = 1800 rpm$$

$$n_{T_{\max}} = n_s (1 - s_{T_{\max}}) = 1455 rpm$$

b)

$$\frac{T_{\max}}{T} = \frac{s_{T_{\max}}^2 + s^2}{2 \cdot s_{T_{\max}} \cdot s} \quad \text{for } T = T_{start} \Rightarrow s = 1$$

$$\frac{T_{\max}}{T_{start}} = \frac{s_{T_{\max}}^2 + 1}{2 \cdot s_{T_{\max}}} \Rightarrow T_{start} = \frac{2 \cdot s_{T_{\max}} \cdot T_{\max}}{s_{T_{\max}}^2 + 1} = 0.92 pu$$



c)

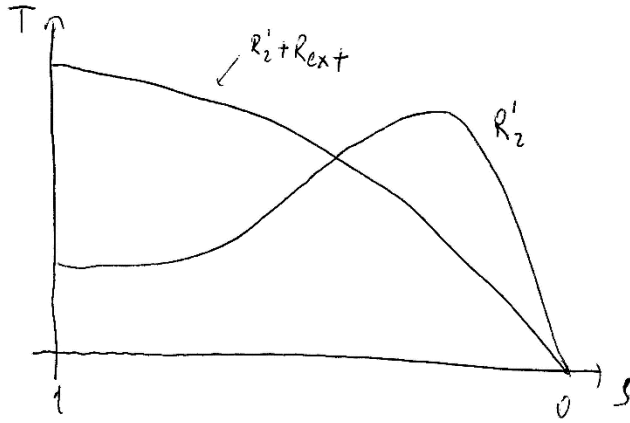

$$s_{T \max} = \frac{R_2'}{\left[ R_{th}^2 + (X_{th} + X_2')^2 \right]^{1/2}}$$

$$R_1 \rightarrow 0 \Rightarrow R_{th} = \left( \frac{X_w}{X_1 + X_w} \right)^2 R_1 \rightarrow 0$$

$$X_1 \rightarrow 0 \Rightarrow X_{th} = X_1 \rightarrow 0$$

$$\Rightarrow s_{T \max} = \frac{R_2'}{X_2'}$$

$$1 = \frac{R_2' + R_{ext}}{X_2'} \Rightarrow R_{ext} = X_2' - R_2' = \frac{R_2'}{s_{T \max}} - R_2'$$

$$\Rightarrow R_{ext} = 2.1 \Omega$$

d)

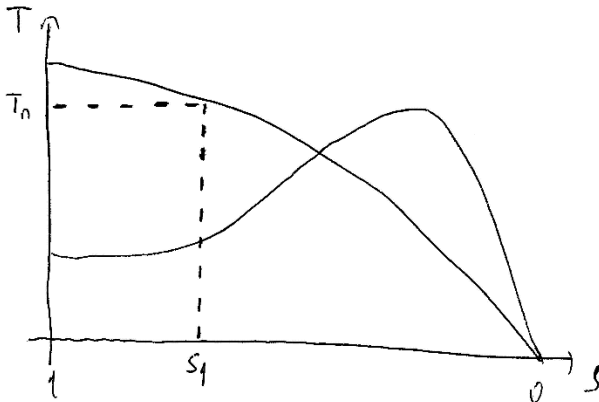

$$s_{T \max} = 1$$

$$T_1 = T_n = 1 \text{ p.u.}$$

$$\frac{T_{\max}}{T_1} = \frac{s_{T \max}^2 + s_1^2}{2 \cdot s_{T \max} \cdot s_1}$$

$$\Rightarrow s_{1,2} = \frac{2s_{T \max} \frac{T_{\max}}{T_1} \pm \left( 2s_{T \max} \frac{T_{\max}}{T_1} \right)^2 - 4s_{T \max}^2}{2}$$

$$s_{1_1} = 4.79$$

$$\boxed{s_{1_2} = 0.21}$$

$$n_1 = (1 - s_1) n_s = 1422 \text{ rpm}$$