

MEC-E1050 Finite Element Method in Solid, week 45/2022

- Determine the horizontal and vertical displacements of node 2. Cross-sectional area of bar 1 is $\sqrt{2}A$ and that of bar 2 is A . Young's modulus of the material is E .

Answer $u_{X2} = \frac{FL}{EA}$, $u_{Y2} = -3\frac{FL}{EA}$

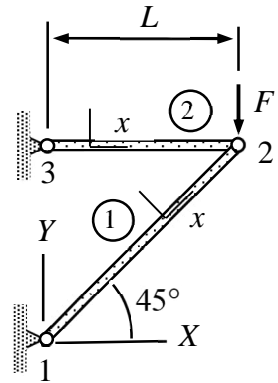

- Determine the nodal displacements of the bar structure (3 bar elements and 1 force element) shown. The length of all the bars is L and the cross-sectional area A . Young's modulus of the material E is constant. First, write down the element table and node table. Second, assemble the system equations. Third, solve the equations for u_{Z1} and u_{X2} .

Answer $u_{Z1} = -\frac{4 FL}{3 EA}$, $u_{X2} = 0$

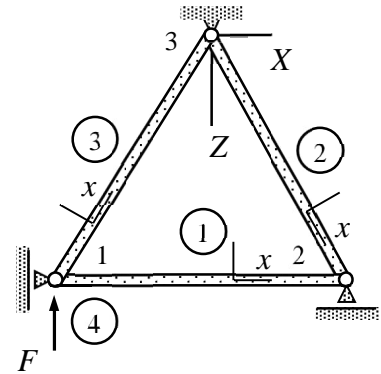

- Determine the nodal displacements when force F is acting on the structure as shown. The cross-sectional area of bars 1,2,3 and 4 is A and the cross-sectional area of bars 5 and 6 is $2\sqrt{2}A$. Young's modulus of the material is E . Use the principle of virtual work.

Answer $u_{X2} = -\frac{1 FL}{3 EA}$, $u_{Z2} = -\frac{2 FL}{3 EA}$

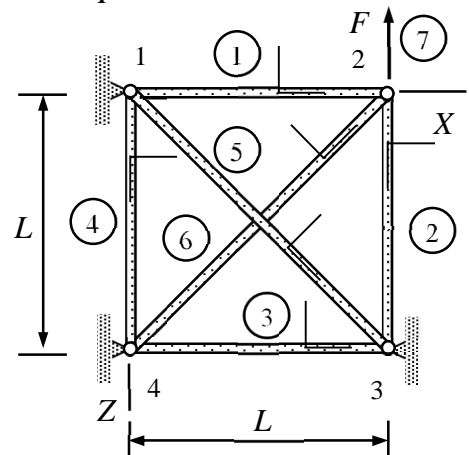

- Consider the XZ-plane bar structure of the figure. Young's modulus E is constant. Cross-sectional areas of bars 2 and 3 are $\sqrt{8}A$ and the cross-sectional area of bar 1 is $2A$. Determine the displacement components u_{X2} , u_{X3} , and u_{Z3} . Use the principle of virtual work.

Answer $u_{X2} = -\frac{1 FL}{2 EA}$, $u_{X3} = u_{Z3} = -\frac{1 FL}{4 EA}$

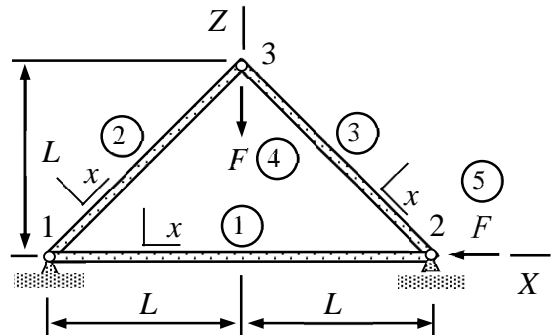

5. Determine the nodal displacements, when force F is acting on the structure as shown in the figure. The cross-sectional area of all the bars is A and the Young's modulus of the material is E . Use the principle of virtual work.

Answer $u_{X2} = -\frac{FL}{EA}$, $u_{Y2} = \frac{FL}{EA}$

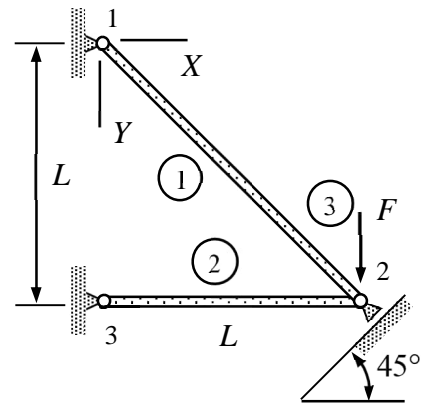

6. Determine displacement u_{Z2} and rotation θ_{Y2} at point 2 of the structure shown. Use two beam elements of equal length. Point moment with magnitude M is acting on node 2. Young's modulus of the material E and the second moment of area I are constants. Use the principle of virtual work.

Answer $u_{Z2} = 0$, $\theta_{Y2} = \frac{1}{8} \frac{ML}{EI}$

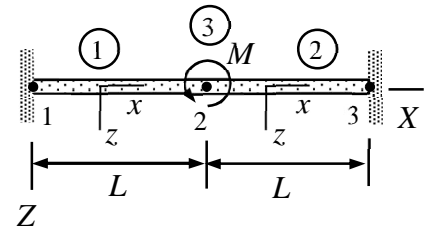

7. Determine the rotation θ_{Y1} at node 1 of the structure shown. Use two beam elements of length L . Assume that the beams are inextensible in the axial directions. Young's modulus of the material E and the second moment of area I are constants. Use the principle of virtual work.

Answer $\theta_{Y1} = -\frac{1}{96} \frac{fL^3}{EI}$

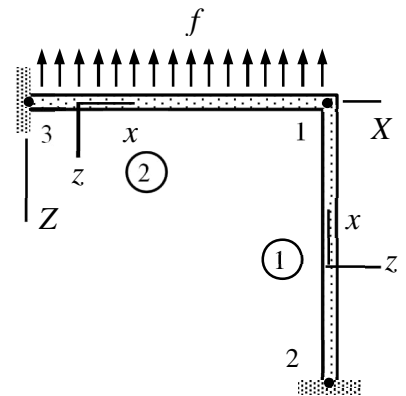

8. The frame of the figure consists of a rigid body (2) and beams (1) and (3). Determine the non-zero displacements and rotations. The beams are identical and can be assumed as inextensible in the axial directions. Displacements are confined to the XZ -plane. Young's modulus E , second moment of area I , and distributed force f acting on element 1 are constants. Use the principle of virtual work.

Answer $u_{Z2} = \frac{1}{48} \frac{fL^4}{EI}$

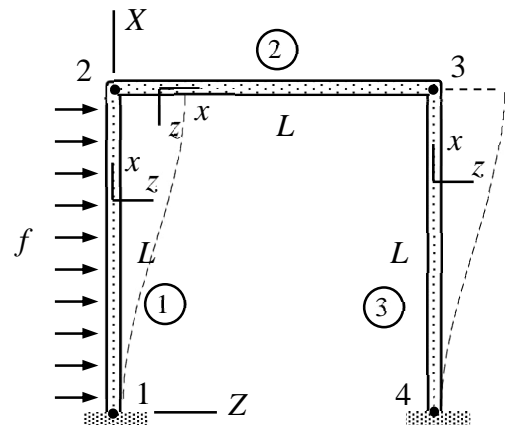

9. Determine the rotation θ_{Y2} at node 2 of the structure loaded by a point moment (magnitude M) acting on node 2. Use beam elements (1) and (2) of length L and a point moment element (3). Assume that the beams are inextensible in the axial directions. Young's modulus E and the second moment of area I are constants. Use the principle of virtual work.

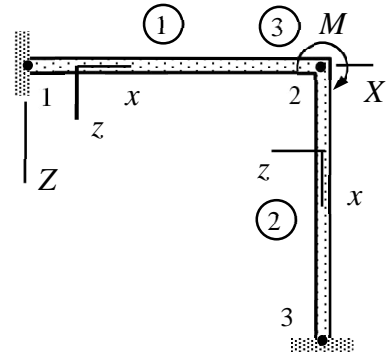

Answer $\theta_{Y2} = -\frac{1}{8} \frac{ML}{EI}$.

10. Beam 1 (length L) of the figure is loaded by its own weight and beam 2 (length L) is assumed weightless. Determine the rotation component θ_{Z2} . Moments of the cross section are A , $I_{yy} = I_{zz} = I$ and $J = 2I$. Young's modulus, shear modulus, and density of the material E , G and ρ are constants.

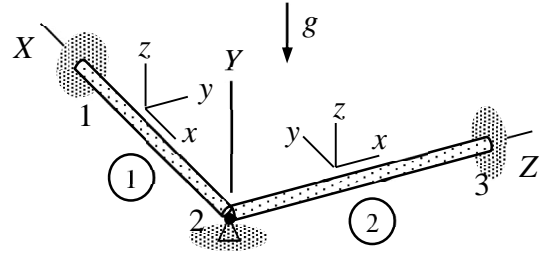

Answer $\theta_{Z2} = -\frac{AgL^3\rho}{24(G+2E)I}$

Determine the horizontal and vertical displacements of node 2. Cross-sectional area of bar 1 is $\sqrt{2}A$ and that of bar 2 is A . Young's modulus of the material is E .

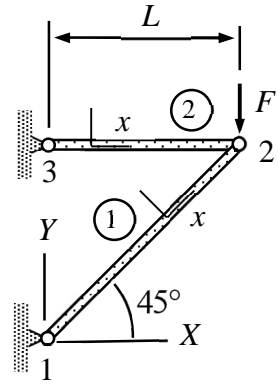

Solution

Element contribution, written in terms of displacement components of the structural coordinate system,

$$\begin{Bmatrix} \mathbf{R}_1 \\ \mathbf{R}_2 \end{Bmatrix} = \frac{EA}{h} \begin{bmatrix} \mathbf{ii}^T & -\mathbf{ii}^T \\ -\mathbf{ii}^T & \mathbf{ii}^T \end{bmatrix} \begin{Bmatrix} \mathbf{a}_1 \\ \mathbf{a}_2 \end{Bmatrix} - \frac{f_x h}{2} \begin{Bmatrix} \mathbf{i} \\ \mathbf{i} \end{Bmatrix}, \text{ where } \mathbf{i} = \frac{1}{h} \begin{Bmatrix} \Delta X \\ \Delta Y \end{Bmatrix}$$

depends on the cross-sectional area A , Young's modulus E , bar length h , force per unit length f_x and the components of the basis vector \vec{i} in the structural coordinate system (the components define the orientation).

Element contributions are first written in terms of the nodal displacements of the structural coordinate system (notice that the point force is treated as a one-node element)

$$\text{Bar 1: } h = \sqrt{2}L, \mathbf{i} = \begin{Bmatrix} \frac{1}{\sqrt{2}} \\ \frac{1}{\sqrt{2}} \end{Bmatrix}, \begin{Bmatrix} F_{X1}^1 \\ F_{Y1}^1 \\ F_{X2}^1 \\ F_{Y2}^1 \end{Bmatrix} = \frac{EA}{2L} \begin{bmatrix} 1 & 1 & -1 & -1 \\ 1 & 1 & -1 & -1 \\ -1 & -1 & 1 & 1 \\ -1 & -1 & 1 & 1 \end{bmatrix} \begin{Bmatrix} 0 \\ 0 \\ u_{X2} \\ u_{Y2} \end{Bmatrix} - \begin{Bmatrix} 0 \\ 0 \\ 0 \\ 0 \end{Bmatrix},$$

$$\text{Bar 2: } h = L, \mathbf{i} = \begin{Bmatrix} 1 \\ 0 \end{Bmatrix}, \begin{Bmatrix} F_{X3}^2 \\ F_{Y3}^2 \\ F_{X2}^2 \\ F_{Y2}^2 \end{Bmatrix} = \frac{EA}{L} \begin{bmatrix} 1 & 0 & -1 & 0 \\ 0 & 0 & 0 & 0 \\ -1 & 0 & 1 & 0 \\ 0 & 0 & 0 & 0 \end{bmatrix} \begin{Bmatrix} 0 \\ 0 \\ u_{X2} \\ u_{Y2} \end{Bmatrix} - \begin{Bmatrix} 0 \\ 0 \\ 0 \\ 0 \end{Bmatrix},$$

$$\text{Force 3: } \begin{Bmatrix} F_{X2}^3 \\ F_{Y2}^3 \end{Bmatrix} = - \begin{Bmatrix} 0 \\ -F \end{Bmatrix}.$$

In assembly, the internal forces acting on the non-constrained directions are added to get the equilibrium equations of the structure. The unknown displacement components follow as the solution to the equilibrium equations:

$$\sum \begin{Bmatrix} F_{X2}^e \\ F_{Y2}^e \end{Bmatrix} = \begin{Bmatrix} F_{X2}^1 \\ F_{Y2}^1 \end{Bmatrix} + \begin{Bmatrix} F_{X2}^2 \\ F_{Y2}^2 \end{Bmatrix} + \begin{Bmatrix} F_{X2}^3 \\ F_{Y2}^3 \end{Bmatrix} = \frac{EA}{2L} \begin{bmatrix} 3 & 1 \\ 1 & 1 \end{bmatrix} \begin{Bmatrix} u_{X2} \\ u_{Y2} \end{Bmatrix} + \begin{Bmatrix} 0 \\ F \end{Bmatrix} = 0 \quad \Leftrightarrow$$

$$u_{X2} = \frac{FL}{EA} \quad \text{and} \quad u_{Y2} = -3 \frac{FL}{EA}. \quad \leftarrow$$

Use the code of MEC-E1050 to check the solution!

Determine the nodal displacements of the bar structure (3 bar elements and 1 force element) shown. The length of all the bars is L and the cross-sectional area A . Young's modulus of the material E is constant. First, write down the element table and node table. Second, assemble the system equations. Third, solve the equations for u_{Z1} and u_{X2} .

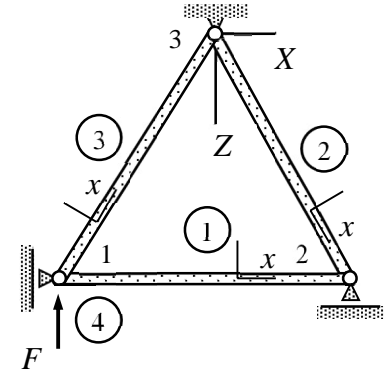

Solution

Element and node tables contain the information needed in the displacement and stress analysis of the structures.

	model	properties	geometry
1	BAR	{ $\{E\}, \{A\}$ }	Line [$\{1, 2\}$]
2	BAR	{ $\{E\}, \{A\}$ }	Line [$\{2, 3\}$]
3	BAR	{ $\{E\}, \{A\}$ }	Line [$\{3, 1\}$]
4	FORCE	{ $0, 0, -F$ }	Point [$\{1\}$]

	{ X, Y, Z }	{ u_x, u_y, u_z }	{ $\theta_x, \theta_y, \theta_z$ }
1	{ $-\frac{L}{2}, 0, \frac{\sqrt{3}L}{2}$ }	{ $0, 0, u_Z[1]$ }	{ $0, 0, 0$ }
2	{ $\frac{L}{2}, 0, \frac{\sqrt{3}L}{2}$ }	{ $u_X[2], 0, 0$ }	{ $0, 0, 0$ }
3	{ $0, 0, 0$ }	{ $0, 0, 0$ }	{ $0, 0, 0$ }

In hand calculations, with simple problems of a few elements, explicit forms of the tables are not necessary. Element contributions need to be written in terms of the displacement and force components of the structural system before assembly. Bar element contribution in terms of displacement and force components of the structural system

$$\begin{Bmatrix} \mathbf{R}_1 \\ \mathbf{R}_2 \end{Bmatrix} = \frac{EA}{h} \begin{bmatrix} \mathbf{ii}^T & -\mathbf{ii}^T \\ -\mathbf{ii}^T & \mathbf{ii}^T \end{bmatrix} \begin{Bmatrix} \mathbf{a}_1 \\ \mathbf{a}_2 \end{Bmatrix} - \frac{f_x h}{2} \begin{Bmatrix} \mathbf{i} \\ \mathbf{i} \end{Bmatrix}, \text{ in which } \mathbf{i} = \frac{1}{h} \begin{Bmatrix} \Delta X \\ \Delta Z \end{Bmatrix} \text{ (in this case)}$$

is convenient in truss calculations:

$$\text{Bar 1: } \begin{Bmatrix} F_{X1}^1 \\ F_{Z1}^1 \\ F_{X2}^1 \\ F_{Z2}^1 \end{Bmatrix} = \frac{EA}{L} \begin{bmatrix} 1 & 0 & -1 & 0 \\ 0 & 0 & 0 & 0 \\ -1 & 0 & 1 & 0 \\ 0 & 0 & 0 & 0 \end{bmatrix} \begin{Bmatrix} 0 \\ u_{Z1} \\ u_{X2} \\ 0 \end{Bmatrix} - \begin{Bmatrix} 0 \\ 0 \\ 0 \\ 0 \end{Bmatrix} \quad (\mathbf{i} = \begin{Bmatrix} 1 \\ 0 \end{Bmatrix}, h = L),$$

$$\text{Bar 2: } \begin{Bmatrix} F_{X3}^2 \\ F_{Z3}^2 \\ F_{X2}^2 \\ F_{Z2}^2 \end{Bmatrix} = \frac{EA}{4L} \begin{bmatrix} 1 & \sqrt{3} & -1 & -\sqrt{3} \\ \sqrt{3} & 3 & -\sqrt{3} & -3 \\ -1 & -\sqrt{3} & 1 & \sqrt{3} \\ -\sqrt{3} & -3 & \sqrt{3} & 3 \end{bmatrix} \begin{Bmatrix} 0 \\ u_{X2} \\ 0 \\ 0 \end{Bmatrix} - \begin{Bmatrix} 0 \\ 0 \\ 0 \\ 0 \end{Bmatrix} \quad (\mathbf{i} = \frac{1}{2} \begin{Bmatrix} 1 \\ \sqrt{3} \end{Bmatrix}, h = L),$$

$$\text{Bar 3: } \begin{Bmatrix} F_{X1}^3 \\ F_{Z1}^3 \\ F_{X3}^3 \\ F_{Z3}^3 \end{Bmatrix} = \frac{EA}{4L} \begin{bmatrix} 1 & -\sqrt{3} & -1 & \sqrt{3} \\ -\sqrt{3} & 3 & \sqrt{3} & -3 \\ -1 & \sqrt{3} & 1 & -\sqrt{3} \\ \sqrt{3} & -3 & -\sqrt{3} & 3 \end{bmatrix} \begin{Bmatrix} 0 \\ u_{Z1} \\ 0 \\ 0 \end{Bmatrix} - \begin{Bmatrix} 0 \\ 0 \\ 0 \\ 0 \end{Bmatrix} \quad (\mathbf{i} = \frac{1}{2} \begin{Bmatrix} 1 \\ -\sqrt{3} \end{Bmatrix}, h = L),$$

$$\text{Force 4: } \begin{Bmatrix} F_{X1}^4 \\ F_{Z1}^4 \end{Bmatrix} = - \begin{Bmatrix} 0 \\ -F \end{Bmatrix}.$$

Equilibrium equations of the nodes, giving displacements as their solution, are obtained by summing the internal forces acting on the nodes (non-constrained directions only):

$$\sum \begin{Bmatrix} F_{Z1}^e \\ F_{X2}^e \end{Bmatrix} = \begin{Bmatrix} F_{Z1}^1 + F_{Z1}^3 + F_{Z1}^4 \\ F_{X2}^1 + F_{X2}^2 \end{Bmatrix} = \begin{Bmatrix} 0 + \frac{3EA}{4L} u_{Z1} + F \\ \frac{EA}{L} u_{X2} + \frac{1EA}{4L} u_{X2} \end{Bmatrix} = \frac{1EA}{4L} \begin{bmatrix} 3 & 0 \\ 0 & 5 \end{bmatrix} \begin{Bmatrix} u_{Z1} \\ u_{X2} \end{Bmatrix} - \begin{Bmatrix} -F \\ 0 \end{Bmatrix} = 0 \quad \Rightarrow$$

$$\begin{Bmatrix} u_{Z1} \\ u_{X2} \end{Bmatrix} = 4 \frac{L}{EA} \begin{bmatrix} 1/3 & 0 \\ 0 & 1/5 \end{bmatrix} \begin{Bmatrix} -F \\ 0 \end{Bmatrix} = -\frac{4FL}{3EA} \begin{Bmatrix} 1 \\ 0 \end{Bmatrix}. \quad \leftarrow$$

Determine the nodal displacements when force F is acting on the structure as shown. The cross-sectional area of bars 1,2,3 and 4 is A and the cross-sectional area of bars 5 and 6 is $2\sqrt{2}A$. Young's modulus of the material is E . Use the principle of virtual work.

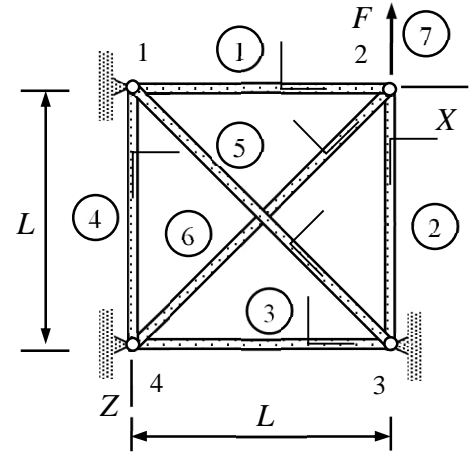

Solution

Element and node tables contain the information needed in displacement and stress analysis of the structure. In hand calculations, it is often enough to complete the figure by the material coordinate systems and express the nodal displacements/rotations in terms symbols for the nodal displacements and rotations and/or values known a priori. The components in the material coordinate systems can also be deduced directly from the figure (in simple cases). Virtual work expression of the bar element is given by

$$\delta W = \delta W^{\text{int}} + \delta W^{\text{ext}} = - \begin{Bmatrix} \delta u_{x1} \\ \delta u_{x2} \end{Bmatrix}^T \left(\frac{EA}{h} \begin{bmatrix} 1 & -1 \\ -1 & 1 \end{bmatrix} \begin{Bmatrix} u_{x1} \\ u_{x2} \end{Bmatrix} - \frac{f_x h}{2} \begin{Bmatrix} 1 \\ 1 \end{Bmatrix} \right).$$

Nodal displacements/rotations of the structure are zeros except u_{X2} and u_{Z2} . Element contributions in their virtual work forms are (nodal displacements of the material coordinate system need to be expressed in terms of the structural system components)

$$\text{Bar 1: } u_{x1} = 0, \quad u_{x2} = u_{X2}: \quad \delta W^1 = -\delta u_{X2} \frac{EA}{L} u_{X2},$$

$$\text{Bar 2: } u_{x2} = u_{Z2}, \quad u_{x3} = 0: \quad \delta W^2 = -\delta u_{Z2} \frac{EA}{L} u_{Z2},$$

$$\text{Bar 3: } u_{x4} = 0 \quad \text{and} \quad u_{x3} = 0: \quad \delta W^3 = 0,$$

$$\text{Bar 4: } u_{x1} = 0 \quad \text{and} \quad u_{x4} = 0: \quad \delta W^4 = 0,$$

$$\text{Bar 5: } u_{x1} = 0 \quad \text{and} \quad u_{x3} = 0: \quad \delta W^5 = 0,$$

$$\text{Bar 6: } u_{x4} = 0, \quad u_{x2} = \frac{1}{\sqrt{2}}(u_{X2} - u_{Z2}): \quad \delta W^6 = -(\delta u_{X2} - \delta u_{Z2}) \frac{EA}{L} (u_{X2} - u_{Z2})$$

$$\text{Force 7: } \delta W^7 = -\delta u_{Z2} F.$$

Virtual work expression of the structure is sum of the element contributions

$$\delta W = \sum_e \delta W^e = \delta W^1 + \delta W^2 + \delta W^3 + \delta W^4 + \delta W^5 + \delta W^6 + \delta W^7 \Rightarrow$$

$$\delta W = -\delta u_{X2} \frac{EA}{L} u_{X2} - \delta u_{Z2} \frac{EA}{L} a_2 + 0 + 0 + 0 + 0 - (\delta u_{X2} - \delta u_{Z2}) \frac{EA}{L} (u_{X2} - u_{Z2}) - \delta u_{Z2} F \Leftrightarrow$$

$$\delta W = -\begin{Bmatrix} \delta u_{X2} \\ \delta u_{Z2} \end{Bmatrix}^T \left(\frac{EA}{L} \begin{bmatrix} 2 & -1 \\ -1 & 2 \end{bmatrix} \begin{Bmatrix} u_{X2} \\ u_{Z2} \end{Bmatrix} - \begin{Bmatrix} 0 \\ -F \end{Bmatrix} \right).$$

Principle of virtual work $\delta W = 0 \forall \delta \mathbf{a}$ and the fundamental lemma of variation calculus in the form $\delta \mathbf{a}^T \mathbf{R} = 0 \forall \delta \mathbf{a} \Leftrightarrow \mathbf{R} = 0$ imply

$$\frac{EA}{L} \begin{bmatrix} 2 & -1 \\ -1 & 2 \end{bmatrix} \begin{Bmatrix} u_{X2} \\ u_{Z2} \end{Bmatrix} - \begin{Bmatrix} 0 \\ -F \end{Bmatrix} = 0 \Leftrightarrow \begin{Bmatrix} u_{X2} \\ u_{Z2} \end{Bmatrix} = \frac{FL}{EA} \frac{1}{3} \begin{bmatrix} 2 & 1 \\ 1 & 2 \end{bmatrix} \begin{Bmatrix} 0 \\ -1 \end{Bmatrix} = -\frac{FL}{EA} \begin{Bmatrix} 1/3 \\ 2/3 \end{Bmatrix}. \quad \leftarrow$$

Consider the XZ -plane bar structure of the figure. Young's modulus E is constant. Cross-sectional areas of bars 2 and 3 are $\sqrt{8}A$ and the cross-sectional area of bar 1 is $2A$. Determine the displacement components u_{X2} , u_{X3} , and u_{Z3} . Use the principle of virtual work.

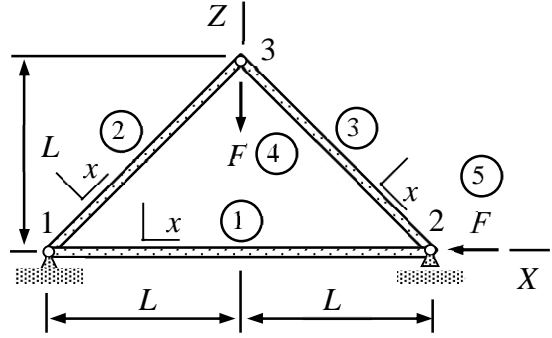

Solution

Virtual work expression of the bar element

$$\delta W = \delta W^{\text{int}} + \delta W^{\text{ext}} = - \begin{Bmatrix} \delta u_{x1} \\ \delta u_{x2} \end{Bmatrix}^T \left(\frac{EA}{h} \begin{bmatrix} 1 & -1 \\ -1 & 1 \end{bmatrix} \begin{Bmatrix} u_{x1} \\ u_{x2} \end{Bmatrix} - \frac{f_x h}{2} \begin{Bmatrix} 1 \\ 1 \end{Bmatrix} \right)$$

depends on the cross-sectional area A , Young's modulus E , bar length h , and force per unit length f_x .

External distributed force vanishes and the unknown displacement components of the structure are u_{X2} , u_{X3} , and u_{Z3} . Virtual work expression of the elements are

Bar 1: $u_{x1} = 0$, $u_{x2} = u_{X2}$,

$$\delta W^1 = - \begin{Bmatrix} 0 \\ \delta u_{X2} \end{Bmatrix}^T \frac{E2A}{2L} \begin{bmatrix} 1 & -1 \\ -1 & 1 \end{bmatrix} \begin{Bmatrix} 0 \\ u_{X2} \end{Bmatrix} = - \begin{Bmatrix} \delta u_{X2} \\ \delta u_{X3} \\ \delta u_{Z3} \end{Bmatrix}^T \frac{EA}{L} \begin{bmatrix} 1 & 0 & 0 \\ 0 & 0 & 0 \\ 0 & 0 & 0 \end{bmatrix} \begin{Bmatrix} u_{X2} \\ u_{X3} \\ u_{Z3} \end{Bmatrix},$$

Bar 2: $u_{x1} = 0$, $u_{x3} = \frac{1}{\sqrt{2}}(u_{X3} + u_{Z3})$

$$\delta W^2 = - \begin{Bmatrix} 0 \\ \delta u_{X3} + \delta u_{Z3} \end{Bmatrix}^T \frac{E\sqrt{8}A}{\sqrt{8}L} \begin{bmatrix} 1 & -1 \\ -1 & 1 \end{bmatrix} \begin{Bmatrix} 0 \\ u_{X3} + u_{Z3} \end{Bmatrix} = - \begin{Bmatrix} \delta u_{X2} \\ \delta u_{X3} \\ \delta u_{Z3} \end{Bmatrix}^T \frac{EA}{L} \begin{bmatrix} 0 & 0 & 0 \\ 0 & 1 & 1 \\ 0 & 1 & 1 \end{bmatrix} \begin{Bmatrix} u_{X2} \\ u_{X3} \\ u_{Z3} \end{Bmatrix}$$

Bar 3: $u_{x3} = \frac{1}{\sqrt{2}}(u_{X3} - u_{Z3})$, $u_{x2} = \frac{1}{\sqrt{2}}u_{X2}$

$$\delta W^3 = - \begin{Bmatrix} \delta u_{X3} - \delta u_{Z3} \\ \delta u_{X2} \end{Bmatrix}^T \frac{E\sqrt{8}A}{\sqrt{8}L} \begin{bmatrix} 1 & -1 \\ -1 & 1 \end{bmatrix} \begin{Bmatrix} u_{X3} - u_{Z3} \\ u_{X2} \end{Bmatrix} = - \begin{Bmatrix} \delta u_{X2} \\ \delta u_{X3} \\ \delta u_{Z3} \end{Bmatrix}^T \frac{EA}{L} \begin{bmatrix} 1 & -1 & 1 \\ -1 & 1 & -1 \\ 1 & -1 & 1 \end{bmatrix} \begin{Bmatrix} u_{X2} \\ u_{X3} \\ u_{Z3} \end{Bmatrix}$$

$$\text{Force 4: } \delta W^4 = - \begin{Bmatrix} \delta u_{X2} \\ \delta u_{X3} \\ \delta u_{Z3} \end{Bmatrix}^T \begin{Bmatrix} 0 \\ 0 \\ F \end{Bmatrix}$$

$$\text{Force 5: } \delta W^5 = - \begin{Bmatrix} \delta u_{X2} \\ \delta u_{X3} \\ \delta u_{Z3} \end{Bmatrix}^T \begin{Bmatrix} F \\ 0 \\ 0 \end{Bmatrix}$$

Virtual work expression of a structure is sum of the element contributions

$$\delta W = - \begin{Bmatrix} \delta u_{X2} \\ \delta u_{X3} \\ \delta u_{Z3} \end{Bmatrix}^T \left(\frac{EA}{L} \begin{bmatrix} 2 & -1 & 1 \\ -1 & 2 & 0 \\ 1 & 0 & 2 \end{bmatrix} \begin{Bmatrix} u_{X2} \\ u_{X3} \\ u_{Z3} \end{Bmatrix} + \begin{Bmatrix} F \\ 0 \\ F \end{Bmatrix} \right).$$

Principle of virtual work and the fundamental lemma of variation calculus imply the linear equation system and thereby the solution to the nodal displacements

$$\frac{EA}{L} \begin{bmatrix} 2 & -1 & 1 \\ -1 & 2 & 0 \\ 1 & 0 & 2 \end{bmatrix} \begin{Bmatrix} u_{X2} \\ u_{X3} \\ u_{Z3} \end{Bmatrix} + F \begin{Bmatrix} 1 \\ 0 \\ 1 \end{Bmatrix} = 0 \Leftrightarrow \begin{Bmatrix} u_{X2} \\ u_{X3} \\ u_{Z3} \end{Bmatrix} = \frac{FL}{EA} \begin{Bmatrix} -1/2 \\ -1/4 \\ -1/4 \end{Bmatrix}. \quad \leftarrow$$

Determine the nodal displacements when force F is acting on the structure as shown in the figure. The cross-sectional area of all the bars is A and the Young's modulus of the material is E . Use the principle of virtual work.

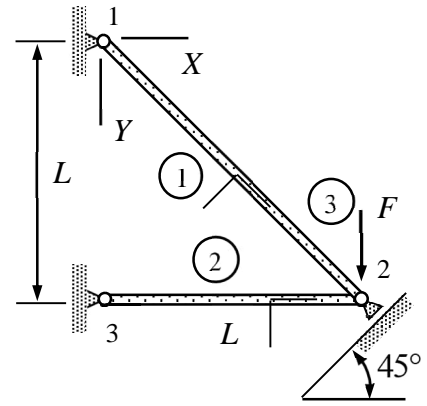

Solution

Virtual work expression of the bar and force elements are given by

$$\delta W = - \begin{Bmatrix} \delta u_{x1} \\ \delta u_{x2} \end{Bmatrix}^T \left(\frac{EA}{h} \begin{bmatrix} 1 & -1 \\ -1 & 1 \end{bmatrix} \begin{Bmatrix} u_{x1} \\ u_{x2} \end{Bmatrix} - \frac{f_x h}{2} \begin{Bmatrix} 1 \\ 1 \end{Bmatrix} \right) \quad \text{and} \quad \delta W = \begin{Bmatrix} \delta u_{X1} \\ \delta u_{Y1} \\ \delta u_{Z1} \end{Bmatrix}^T \begin{Bmatrix} F_X \\ F_Y \\ F_Z \end{Bmatrix}.$$

Nodal displacements of the structure are zeros except for node 2. Notice that the node is allowed to move only along the frictionless plane. The unit normal vector to the plane and displacement of node 2 (omitting the constraint first) are $\vec{n} = -(\vec{I} + \vec{J})/\sqrt{2}$, $\vec{u}_2 = u_{X2}\vec{I} + u_{Y2}\vec{J}$. Therefore (see the formulae collection "frictionless contact"):

$$\vec{n} \cdot \vec{u}_2 = -\frac{1}{\sqrt{2}}(\vec{I} + \vec{J}) \cdot (u_{X2}\vec{I} + u_{Y2}\vec{J}) = -\frac{1}{\sqrt{2}}(u_{X2} + u_{Y2}) = 0 \quad \Leftrightarrow \quad u_{Y2} = -u_{X2}.$$

Element contributions need to be written in terms of displacement components of the structural system. Due to the constraint at node 2, the unknown displacement components can be chosen to be u_{X2} (say).

Bar 1: $u_{x1} = 0$ and $u_{x2} = 0 \Rightarrow \delta W^1 = 0$,

Bar 2: $u_{x3} = 0$ and $u_{x2} = u_{X2} \Rightarrow \delta W^2 = -\delta u_{X2} \frac{EA}{L} u_{X2}$,

Force 3: $\delta W^3 = \delta u_{Y2} F = -\delta u_{X2} F$.

Virtual work expression of the structure is sum of the element contributions

$$\delta W = \sum_e \delta W^e = \delta W^1 + \delta W^2 + \delta W^3 = -\delta u_{X2} \frac{EA}{L} u_{X2} - \delta u_{X2} F = -\delta u_{X2} \left(\frac{EA}{L} u_{X2} + F \right)$$

Principle of virtual work $\delta W = 0 \forall \delta \mathbf{a}$ and the fundamental lemma of variation calculus in the form $\delta \mathbf{a}^T \mathbf{R} = 0 \forall \delta \mathbf{a} \Leftrightarrow \mathbf{R} = 0$ imply

$$\frac{EA}{L} u_{X2} + F = 0 \quad \Leftrightarrow \quad u_{X2} = -\frac{FL}{EA} \quad \Rightarrow \quad u_{Y2} = -u_{X2} = \frac{FL}{EA}. \quad \leftarrow$$

Determine displacement u_{z2} and rotation θ_{y2} at point 2 of the structure shown. Use two beam elements of equal length. Point moment with magnitude M is acting on node 2. Young's modulus of the material E and the second moment of area I are constants. Use the principle of virtual work.

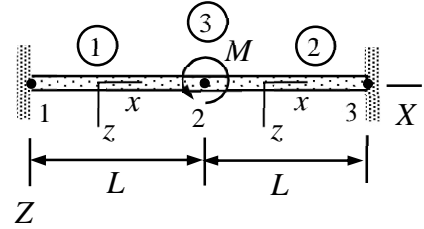

Solution

Virtual work expression of the beam xz -plane bending and point moments elements are

$$\delta W = - \begin{Bmatrix} \delta u_{z1} \\ \delta \theta_{y1} \\ \delta u_{z2} \\ \delta \theta_{y2} \end{Bmatrix}^T \left(\frac{EI_{yy}}{h^3} \begin{bmatrix} 12 & -6h & -12 & -6h \\ -6h & 4h^2 & 6h & 2h^2 \\ -12 & 6h & 12 & 6h \\ -6h & 2h^2 & 6h & 4h^2 \end{bmatrix} \begin{Bmatrix} u_{z1} \\ \theta_{y1} \\ u_{z2} \\ \theta_{y2} \end{Bmatrix} - \frac{f_z h}{12} \begin{Bmatrix} 6 \\ -h \\ 6 \\ h \end{Bmatrix} \right) \text{ and } \delta W = \begin{Bmatrix} \delta \theta_{X1} \\ \delta \theta_{Y1} \\ \delta \theta_{Z1} \end{Bmatrix}^T \begin{Bmatrix} M_X \\ M_Y \\ M_Z \end{Bmatrix}.$$

Except u_{z2} and θ_{y2} , nodal displacements/rotations of the structure are zeros. The bar loading mode can be omitted as the axial loading and axial displacements vanish. Here, the axes of material and structural coordinate systems are aligned:

Beam 1: $u_{z1} = 0, \theta_{y1} = 0, u_{z2} = u_{z2}$ and $\theta_{y2} = \theta_{y2}$

$$\delta W^1 = - \begin{Bmatrix} 0 \\ 0 \\ \delta u_{z2} \\ \delta \theta_{y2} \end{Bmatrix}^T \left[\frac{EI}{L^3} \begin{bmatrix} 12 & -6L & -12 & -6L \\ -6L & 4L^2 & 6L & 2L^2 \\ -12 & 6L & 12 & 6L \\ -6L & 2L^2 & 6L & 4L^2 \end{bmatrix} \begin{Bmatrix} 0 \\ 0 \\ u_{z2} \\ \theta_{y2} \end{Bmatrix} \right] = - \begin{Bmatrix} \delta u_{z2} \\ \delta \theta_{y2} \end{Bmatrix}^T \frac{EI}{L^3} \begin{bmatrix} 12 & 6L \\ 6L & 4L^2 \end{bmatrix} \begin{Bmatrix} u_{z2} \\ \theta_{y2} \end{Bmatrix}.$$

Beam 2: $u_{z2} = u_{z2}, \theta_{y2} = \theta_{y2}, u_{z3} = 0$ and $\theta_{y3} = 0$

$$\delta W^2 = - \begin{Bmatrix} \delta u_{z2} \\ \delta \theta_{y2} \\ 0 \\ 0 \end{Bmatrix}^T \left[\frac{EI}{L^3} \begin{bmatrix} 12 & -6L & -12 & -6L \\ -6L & 4L^2 & 6L & 2L^2 \\ -12 & 6L & 12 & 6L \\ -6L & 2L^2 & 6L & 4L^2 \end{bmatrix} \begin{Bmatrix} u_{z2} \\ \theta_{y2} \\ 0 \\ 0 \end{Bmatrix} \right] = - \begin{Bmatrix} \delta u_{z2} \\ \delta \theta_{y2} \end{Bmatrix}^T \frac{EI}{L^3} \begin{bmatrix} 12 & -6L \\ -6L & 4L^2 \end{bmatrix} \begin{Bmatrix} u_{z2} \\ \theta_{y2} \end{Bmatrix}.$$

Moment 3:

$$\delta W^3 = \begin{Bmatrix} \delta \theta_{X2} \\ \delta \theta_{Y2} \\ \delta \theta_{Z2} \end{Bmatrix}^T \begin{Bmatrix} 0 \\ M \\ 0 \end{Bmatrix} = \delta \theta_{Y2} M = \begin{Bmatrix} \delta \theta_{Z2} \\ \delta \theta_{Y2} \end{Bmatrix}^T \begin{Bmatrix} 0 \\ M \end{Bmatrix}.$$

Virtual work expression of the structure is sum of the element contributions

$$\delta W = \sum_e \delta W^e = \delta W^1 + \delta W^2 + \delta W^3 \Rightarrow$$

$$\delta W = - \begin{Bmatrix} \delta u_{Z2} \\ \delta \theta_{Y2} \end{Bmatrix}^T \left(\frac{EI}{L^3} \begin{bmatrix} 12 & 6L \\ 6L & 4L^2 \end{bmatrix} \begin{Bmatrix} u_{Z2} \\ \theta_{Y2} \end{Bmatrix} + \frac{EI}{L^3} \begin{bmatrix} 12 & -6L \\ -6L & 4L^2 \end{bmatrix} \begin{Bmatrix} u_{Z2} \\ \theta_{Y2} \end{Bmatrix} - \begin{Bmatrix} 0 \\ M \end{Bmatrix} \right) \Leftrightarrow$$

$$\delta W = - \begin{Bmatrix} \delta u_{Z2} \\ \delta \theta_{Y2} \end{Bmatrix}^T \left(\frac{EI}{L^3} \begin{bmatrix} 24 & 0 \\ 0 & 8L^2 \end{bmatrix} \begin{Bmatrix} u_{Z2} \\ \theta_{Y2} \end{Bmatrix} - \begin{Bmatrix} 0 \\ M \end{Bmatrix} \right).$$

Principle of virtual work $\delta W = 0 \forall \delta \mathbf{a}$ and the fundamental lemma of variation calculus in the form $\delta \mathbf{a}^T \mathbf{R} = 0 \forall \delta \mathbf{a} \Leftrightarrow \mathbf{R} = 0$ imply

$$\frac{EI}{L^3} \begin{bmatrix} 24 & 0 \\ 0 & 8L^2 \end{bmatrix} \begin{Bmatrix} u_{Z2} \\ \theta_{Y2} \end{Bmatrix} - \begin{Bmatrix} 0 \\ M \end{Bmatrix} = 0 \quad \Leftrightarrow \quad \begin{Bmatrix} u_{Z2} \\ \theta_{Y2} \end{Bmatrix} = \frac{1}{8} \frac{ML}{EI} \begin{Bmatrix} 0 \\ 1 \end{Bmatrix}. \quad \leftarrow$$

Determine the rotation θ_{Y1} at node 1 of the structure shown. Use two beam elements of length L . Assume that the beams are inextensible in the axial directions. Young's modulus of the material E and the second moment of area I are constants. Use the principle of virtual work.

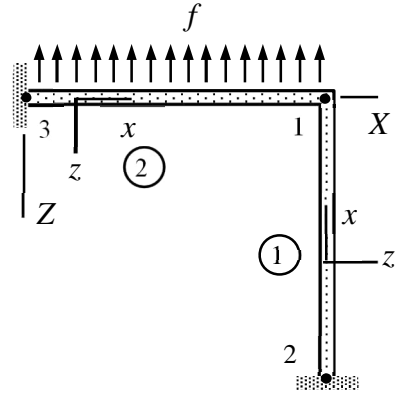

Solution

Virtual work expression of the xz -plane bending beam element

$$\delta W = - \begin{Bmatrix} \delta u_{z1} \\ \delta \theta_{y1} \\ \delta u_{z2} \\ \delta \theta_{y2} \end{Bmatrix}^T \left(\frac{EI_{yy}}{h^3} \begin{bmatrix} 12 & -6h & -12 & -6h \\ -6h & 4h^2 & 6h & 2h^2 \\ -12 & 6h & 12 & 6h \\ -6h & 2h^2 & 6h & 4h^2 \end{bmatrix} \begin{Bmatrix} u_{z1} \\ \theta_{y1} \\ u_{z2} \\ \theta_{y2} \end{Bmatrix} - \frac{f_z h}{12} \begin{Bmatrix} 6 \\ -h \\ 6 \\ h \end{Bmatrix} \right)$$

depends on the second moment of cross-section area I_{yy} , Young's modulus E , beam length h , and force per unit length f_z .

The displacement and rotation components of the material coordinate system need to be expressed in terms of the components of the structural system. As beams are inextensible in the axial directions, the structure has only the rotation degree of freedom θ_{Y1} and it is enough to consider bending in the xz -plane only.

Beam 1: $u_{z2} = 0$, $\theta_{y2} = 0$, $u_{z1} = 0$, $\theta_{y1} = \theta_{Y1}$, and $f_z = 0$

$$\delta W^1 = - \begin{Bmatrix} 0 \\ 0 \\ 0 \\ \delta \theta_{Y1} \end{Bmatrix}^T \left(\frac{EI}{L^3} \begin{bmatrix} 12 & -6L & -12 & -6L \\ -6L & 4L^2 & 6L & 2L^2 \\ -12 & 6L & 12 & 6L \\ -6L & 2L^2 & 6L & 4L^2 \end{bmatrix} \begin{Bmatrix} 0 \\ 0 \\ 0 \\ \theta_{Y1} \end{Bmatrix} - \frac{0L}{12} \begin{Bmatrix} 6 \\ -L \\ 6 \\ L \end{Bmatrix} \right) = -\delta \theta_{Y1} \frac{EI}{L^3} 4L^2 \theta_{Y1}$$

Beam 2: $u_{z3} = 0$, $\theta_{y3} = 0$, $u_{z1} = 0$, $\theta_{y1} = \theta_{Y1}$, and $f_z = -f$

$$\delta W^2 = - \begin{Bmatrix} 0 \\ 0 \\ 0 \\ \delta \theta_{Y1} \end{Bmatrix}^T \left(\frac{EI}{L^3} \begin{bmatrix} 12 & -6L & -12 & -6L \\ -6L & 4L^2 & 6L & 2L^2 \\ -12 & 6L & 12 & 6L \\ -6L & 2L^2 & 6L & 4L^2 \end{bmatrix} \begin{Bmatrix} 0 \\ 0 \\ 0 \\ \theta_{Y1} \end{Bmatrix} - \frac{-fL}{12} \begin{Bmatrix} 6 \\ -L \\ 6 \\ L \end{Bmatrix} \right) = -\delta \theta_{Y1} \left(\frac{EI}{L^3} 4L^2 \theta_{Y1} + \frac{fL^2}{12} \right)$$

Virtual work expression of the structure is obtained by summing the element contributions. After that, the virtual work expression is rearranged into the standard form (similar to the virtual work expression of an element):

$$\delta W = \delta W^1 + \delta W^2 = -\delta\theta_{Y1} \frac{EI}{L^3} 4L^2 \theta_{Y1} - \delta\theta_{Y1} \left(\frac{EI}{L^3} 4L^2 \theta_{Y1} + \frac{fL^2}{12} \right) = -\delta\theta_{Y1} \left(8 \frac{EI}{L} \theta_{Y1} + \frac{fL^2}{12} \right).$$

Principle of virtual work $\delta W = 0 \quad \forall \delta \mathbf{a}$ and the fundamental lemma of variation calculus imply the equilibrium equation and thereby solution to θ_{Y1}

$$8 \frac{EI}{L} \theta_{Y1} + \frac{fL^2}{12} = 0 \quad \Leftrightarrow \quad \theta_{Y1} = -\frac{1}{96} \frac{fL^3}{EI}. \quad \leftarrow$$

The frame of the figure consists of a rigid body (2) and beams (1) and (3). Determine the non-zero displacements and rotations. The beams are identical and can be assumed as inextensible in the axial directions. Displacements are confined to the XZ - plane. Young's modulus E , second moment of area I , and the distributed force f acting on element 1 are constants. Use the principle of virtual work.

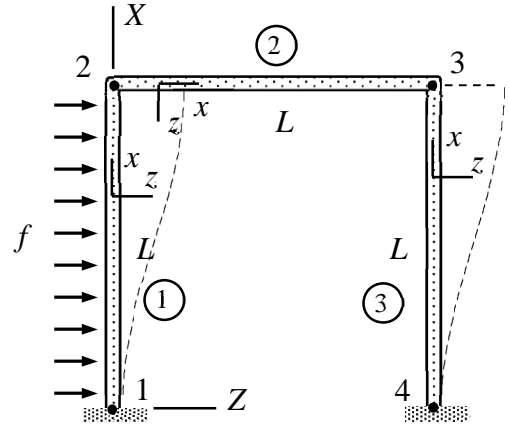

Solution

As element 2 is a rigid body and the other beams are inextensible in the axial directions, only the horizontal displacement components $u_{Z3} = u_{Z2}$ are non-zeros. Element contributions to the virtual work expression are

$$\delta W^1 = - \begin{Bmatrix} 0 \\ 0 \\ \delta u_{Z2} \\ 0 \end{Bmatrix}^T \left(\frac{EI}{L^3} \begin{bmatrix} 12 & -6L & -12 & -6L \\ -6L & 4L^2 & 6L & 2L^2 \\ -12 & 6L & 12 & 6L \\ -6L & 2L^2 & 6L & 4L^2 \end{bmatrix} \begin{Bmatrix} 0 \\ 0 \\ u_{Z2} \\ 0 \end{Bmatrix} - \frac{fL}{12} \begin{Bmatrix} 6 \\ -L \\ 6 \\ L \end{Bmatrix} \right) = -\delta u_{Z2} \left(12 \frac{EI}{L^3} u_{Z2} - \frac{fL}{2} \right),$$

$$\delta W^2 = 0$$

$$\delta W^3 = - \begin{Bmatrix} 0 \\ 0 \\ \delta u_{Z2} \\ 0 \end{Bmatrix}^T \left(\frac{EI}{L^3} \begin{bmatrix} 12 & -6L & -12 & -6L \\ -6L & 4L^2 & 6L & 2L^2 \\ -12 & 6L & 12 & 6L \\ -6L & 2L^2 & 6L & 4L^2 \end{bmatrix} \begin{Bmatrix} 0 \\ 0 \\ u_{Z2} \\ 0 \end{Bmatrix} \right) = -\delta u_{Z2} 12 \frac{EI}{L^3} u_{Z2}$$

Virtual work expression of structure is the sum of element contributions

$$\delta W = \delta W^1 + \delta W^2 + \delta W^3 = -\delta u_{Z2} \left(24 \frac{EI}{L^3} u_{Z2} - \frac{fL}{2} \right)$$

Principle of virtual work $\delta W = 0 \forall \delta a$ and the fundamental lemma of variation calculus imply

$$u_{Z2} = \frac{1}{48} \frac{fL^4}{EI} \quad \leftarrow$$

Determine the rotation θ_{Y2} at node 2 of the structure loaded by a point moment (magnitude M) acting on node 2. Use beam elements (1) and (2) of length L and a point moment element (3). Assume that the beams are inextensible in the axial directions. Young's modulus E and the second moment of area I are constants. Use the principle of virtual work.

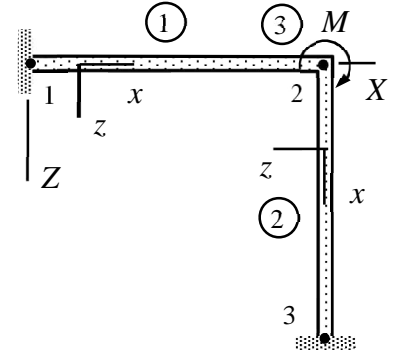

Solution

In a planar problem, torsion and out-plane bending deformation modes can be omitted. As beams are assumed to be inextensible in the axial direction and there are no axial distributed forces, the bar mode virtual work expression vanishes. Virtual work expressions of the beam xz -plane bending element and point force/moment elements are given by

$$\delta W = - \begin{Bmatrix} \delta u_{z1} \\ \delta \theta_{y1} \\ \delta u_{z2} \\ \delta \theta_{y2} \end{Bmatrix}^T \left(\frac{EI_{yy}}{h^3} \begin{bmatrix} 12 & -6h & -12 & -6h \\ -6h & 4h^2 & 6h & 2h^2 \\ -12 & 6h & 12 & 6h \\ -6h & 2h^2 & 6h & 4h^2 \end{bmatrix} \begin{Bmatrix} u_{z1} \\ \theta_{y1} \\ u_{z2} \\ \theta_{y2} \end{Bmatrix} - \frac{f_z h}{12} \begin{Bmatrix} 6 \\ -h \\ 6 \\ h \end{Bmatrix} \right),$$

$$\delta W = \begin{Bmatrix} \delta u_{X1} \\ \delta u_{Y1} \\ \delta u_{Z1} \end{Bmatrix}^T \begin{Bmatrix} F_{X1} \\ F_{Y1} \\ F_{Z1} \end{Bmatrix} + \begin{Bmatrix} \delta \theta_{X1} \\ \delta \theta_{Y1} \\ \delta \theta_{Z1} \end{Bmatrix}^T \begin{Bmatrix} M_{X1} \\ M_{Y1} \\ M_{Z1} \end{Bmatrix}.$$

Nodal displacements/rotations of the structure are clearly zeros except those of node 2. Displacement of node 2 vanishes as both beams are inextensible in the axial directions. Therefore, the only non-zero displacement/rotation component of the structure is θ_{Y2} .

Beam 1: $u_{z1} = 0$, $\theta_{y1} = 0$, $u_{z2} = 0$, and $\theta_{y2} = \theta_{Y2}$

$$\delta W^1 = - \begin{Bmatrix} 0 \\ 0 \\ 0 \\ \delta \theta_{Y2} \end{Bmatrix}^T \frac{EI}{L^3} \begin{bmatrix} 12 & -6L & -12 & -6L \\ -6L & 4L^2 & 6L & 2L^2 \\ -12 & 6L & 12 & 6L \\ -6L & 2L^2 & 6L & 4L^2 \end{bmatrix} \begin{Bmatrix} 0 \\ 0 \\ 0 \\ \theta_{Y2} \end{Bmatrix} = -\delta \theta_{Y2} 4 \frac{EI}{L} \theta_{Y2}.$$

Beam 2: $u_{z2} = 0$, $\theta_{y2} = \theta_{Y2}$, $u_{z3} = 0$, and $\theta_{y3} = 0$

$$\delta W^2 = - \begin{Bmatrix} 0 \\ \delta \theta_{Y2} \\ 0 \\ 0 \end{Bmatrix}^T \frac{EI}{L^3} \begin{bmatrix} 12 & -6L & -12 & -6L \\ -6L & 4L^2 & 6L & 2L^2 \\ -12 & 6L & 12 & 6L \\ -6L & 2L^2 & 6L & 4L^2 \end{bmatrix} \begin{Bmatrix} 0 \\ \theta_{Y2} \\ 0 \\ 0 \end{Bmatrix} = -\delta \theta_{Y2} 4 \frac{EI}{L} \theta_{Y2}.$$

Point moment 3:

$$\delta W^3 = \begin{Bmatrix} \delta u_{X2} \\ \delta u_{Y2} \\ \delta u_{Z2} \end{Bmatrix}^T \begin{Bmatrix} F_{X2} \\ F_{Y2} \\ F_{Z2} \end{Bmatrix} + \begin{Bmatrix} \delta \theta_{X2} \\ \delta \theta_{Y2} \\ \delta \theta_{Z2} \end{Bmatrix}^T \begin{Bmatrix} M_{X2} \\ M_{Y2} \\ M_{Z2} \end{Bmatrix} = -\delta \theta_{Y2} M .$$

Virtual work expression of the structure is sum of the element contributions

$$\delta W = \sum_e \delta W^e = \delta W^1 + \delta W^2 + \delta W^3 \Rightarrow$$

$$\delta W = -\delta \theta_{Y2} 4 \frac{EI}{L} \theta_{Y2} - \delta \theta_{Y2} 4 \frac{EI}{L} \theta_{Y2} + 0 - \delta \theta_{Y2} M = -\delta \theta_{Y2} \left(8 \frac{EI}{L} \theta_{Y2} + M \right) .$$

Principle of virtual work $\delta W = 0 \forall \delta \mathbf{a}$ and the fundamental lemma of variation calculus in the form $\delta \mathbf{a}^T \mathbf{R} = 0 \forall \delta \mathbf{a} \Leftrightarrow \mathbf{R} = 0$ imply

$$8 \frac{EI}{L} \theta_{Y2} + M = 0 \quad \Leftrightarrow \quad \theta_{Y2} = -\frac{1}{8} \frac{ML}{EI} . \quad \leftarrow$$

Beam 1 (length L) of the figure is loaded by its own weight and beam 2 (length L) is assumed weightless. Determine the rotation component θ_{Z2} . Moments of the cross section are A , $I_{yy} = I_{zz} = I$ and $J = 2I$. Young's modulus, shear modulus, and density of the material E , G and ρ are constants.

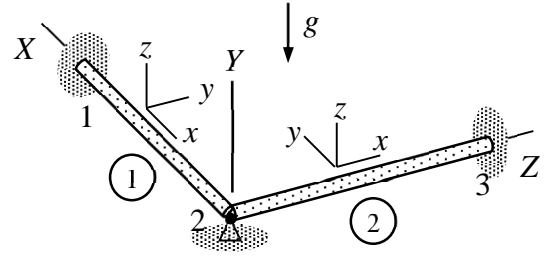

Solution

The only non-zero nodal displacement/rotation of the structure is θ_{Z2} . The virtual work expression of the structure is the sum of the virtual work expressions of the elements which consist of parts coming from bending, torsion etc. For beam 1 $\theta_{y2} = \theta_{Z2}$ and $f_z = -A\rho g$. The non-zero contribution to the virtual work expression comes from bending in xz -plane:

$$\delta W^{\text{int}} = - \begin{Bmatrix} 0 \\ 0 \\ 0 \\ \delta\theta_{Z2} \end{Bmatrix}^T \frac{EI}{L^3} \begin{bmatrix} 12 & -6L & -12 & -6L \\ -6L & 4L^2 & 6L & 2L^2 \\ -12 & 6L & 12 & 6L \\ -6L & 2L^2 & 6L & 4L^2 \end{bmatrix} \begin{Bmatrix} 0 \\ 0 \\ 0 \\ \theta_{Z2} \end{Bmatrix} = -\delta\theta_{Z2} \frac{4EI}{L} \theta_{Z2},$$

$$\delta W^{\text{ext}} = \begin{Bmatrix} 0 \\ 0 \\ 0 \\ \delta\theta_{Z2} \end{Bmatrix}^T \frac{(-A\rho g)L}{12} \begin{Bmatrix} 6 \\ -L \\ 6 \\ L \end{Bmatrix} = -\delta\theta_{Z2} \frac{A\rho g L^2}{12}.$$

For beam 2 $\theta_{x2} = \theta_{Z2}$ and the non-zero contribution to the virtual work expression comes from the torsion mode

$$\delta W^{\text{int}} = - \begin{Bmatrix} \delta\theta_{Z2} \\ 0 \end{Bmatrix}^T \frac{G2I}{L} \begin{bmatrix} 1 & -1 \\ -1 & 1 \end{bmatrix} \begin{Bmatrix} \theta_{Z2} \\ 0 \end{Bmatrix} = -\delta\theta_{Z2} \frac{2GI}{L} \theta_{Z2}.$$

Virtual work expression of the structure is the sum of the element contributions

$$\delta W = -\delta\theta_{Z2} \frac{4EI}{L} \theta_{Z2} - \delta\theta_{Z2} \frac{A\rho g L^2}{12} - \delta\theta_{Z2} \frac{2GI}{L} \theta_{Z2} = -\delta\theta_{Z2} \left(2I \frac{2E+G}{L} \theta_{Z2} + \frac{A\rho g L^2}{12} \right)$$

Principle of virtual work $\delta W = 0 \quad \forall \delta a$ and the fundamental lemma of variation calculus give

$$\delta W = -\delta\theta_{Z2} \left(2I \frac{2E+G}{L} \theta_{Z2} + \frac{A\rho g L^2}{12} \right) = 0 \quad \forall \delta\theta_{Z2} \Leftrightarrow$$

$$2I \frac{2E+G}{L} \theta_{Z2} + \frac{A\rho g L^2}{12} = 0 \Leftrightarrow \theta_{Z2} = -\frac{\rho g A L^3}{24I(2E+G)}. \quad \leftarrow$$