

2.1

In what ways can the park relate to its spatial environment?

Wie kann Bezug auf die räumliche Umgebung genommen werden?

¿Cómo puede favorecerse la relación con el entorno espacial?

- Park Pawlowsk, Charles Cameron + Pietro Gonzaga, 19th century
- Großer Tiergarten, Georg Wenzeslaus von Knobelsdorff + Peter Joseph Lenné, 18.-19. Jhd.
- 04 Geometrical Garden, Carl Theodor Sørensen, 1945-1984
- Parc François Mitterrand, Desvigne & Dalnoky, 1994
- Neue Wiesen, Schirmer + Kernbach, 1998
- Interpolis Garden, West 8, 1998
- 06 MFO-Park, Planergemeinschaft Burckhardtpartner / Raderschall, 2001
- Neue Gärten auf dem Dycker Feld, RMP Landschaftsarchitekten, 2002
- Landschaftspark Adlershof, Büro Kiefer, 2005
- 07 Landschaftspark Riem, Latitude Nord, 2005
- Louvre-Lens Museum Park, mosbach paysagistes + SANAA, 2005
- Parque Metropolitano del Agua, aldayjover arquitectura y paisaje, Christine Dalnoky, 2008
- Dwaalster Park, LOLA, Deltavormgroep + Piet Oudolf, 2011
- Landschaftspark Wartenberger Feldmark, plancontext, 2012

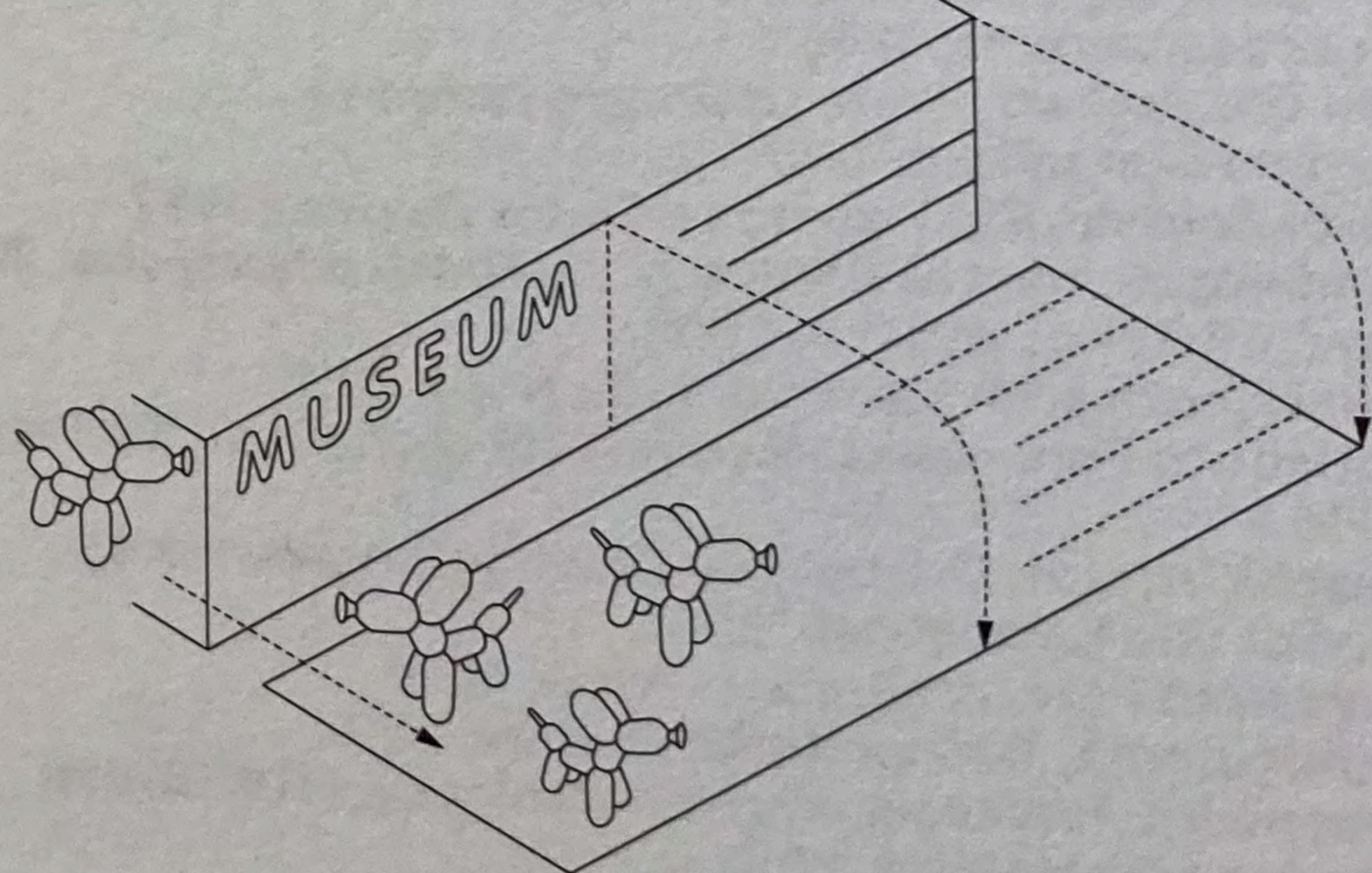
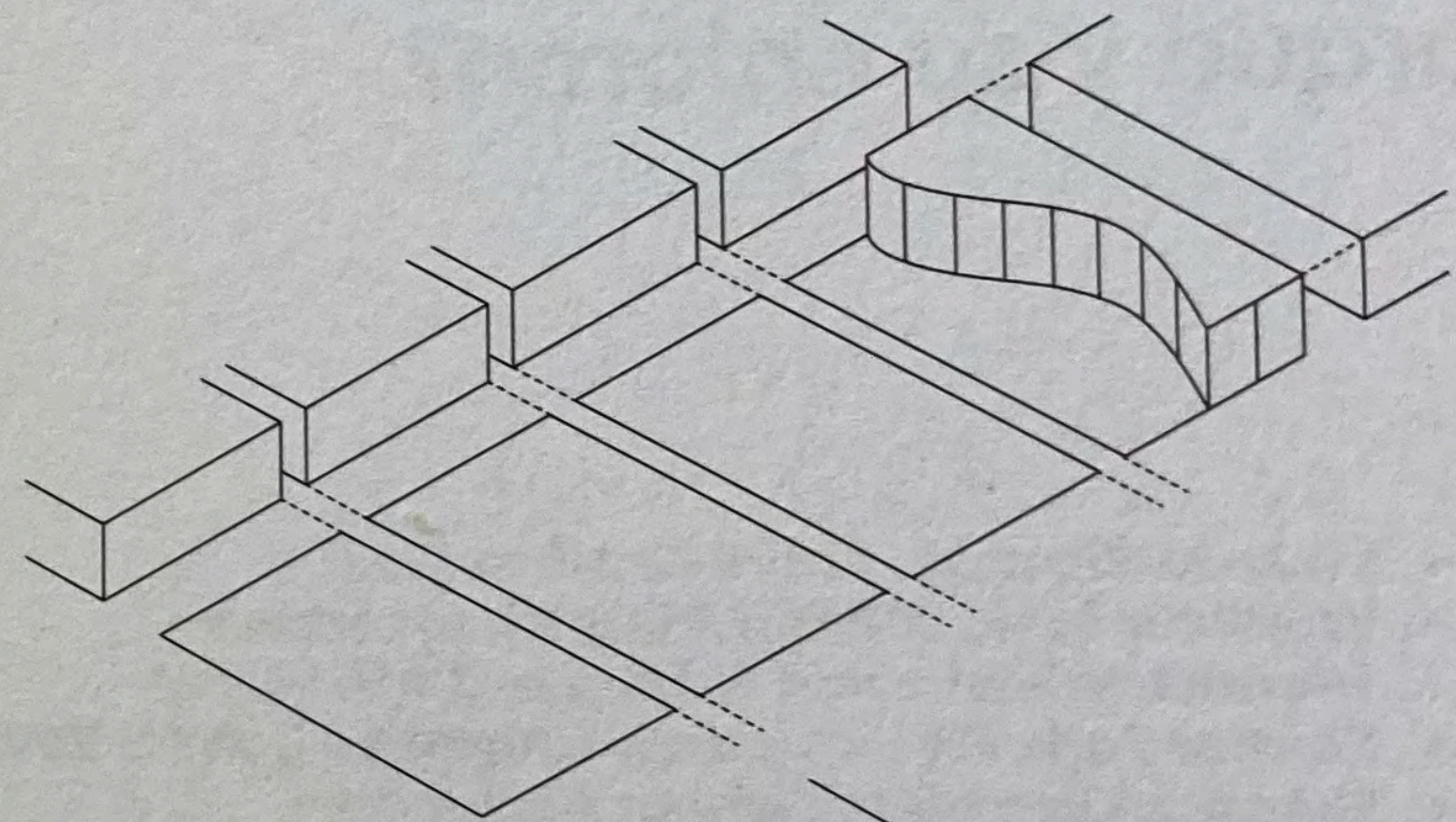
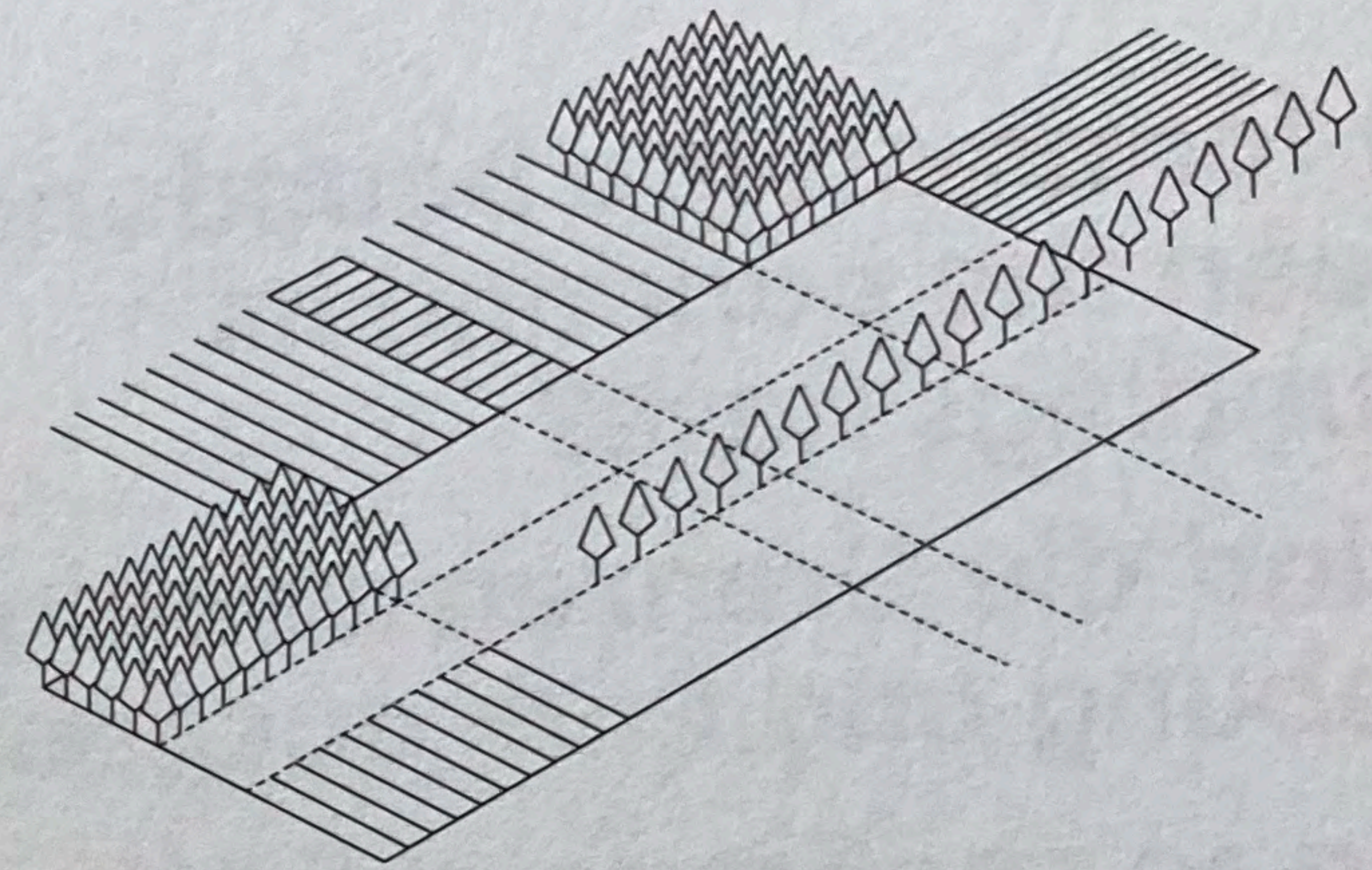

2.4

How is it possible to design without using additional material?

Wie kann ohne zusätzlichen Materialeinsatz gestaltet werden?

¿Cómo puede configurarse el paisaje sin aportación adicional de materiales?

- Line Made By Walking, Richard Long, 1967
- Double Negative, Michael Heizer, 1969
- Ego-zentrischer Steinkreis, Timm Ullrichs, 1978
- Lambton Earthwork, Andy Goldsworthy, 1988
- The Crazannes Quarries, Bernard Lassus, 1997
- Geraldton Mine Project, Martha Schwartz, 1998
- 04 Route der Industriekultur, 1998
- Negev Phosphate Works, Shlomo Aronson, 2000
- Cardada Geobservatory, Studio Bürgi, 2000
- Sky Garden, James Turrell, 2005
- Punta Pite, Estudio del Paisaje Teresa Moller & Asociados, 2005
- Neue Landschaft Ronneburg, fagus FachGesellschaft für Umweltplanung und Stadtentwicklung, 2007
- Black Rock Desert, Jim Denevan, 2008
- Alp Transit Depot, Atelier Girot, 2009
- Cap de Creus, EMF paisatge, 2010
- Adequació de l'espai natural del jaciment romà de Can Tacó, Toni Gironès Saderra, 2012

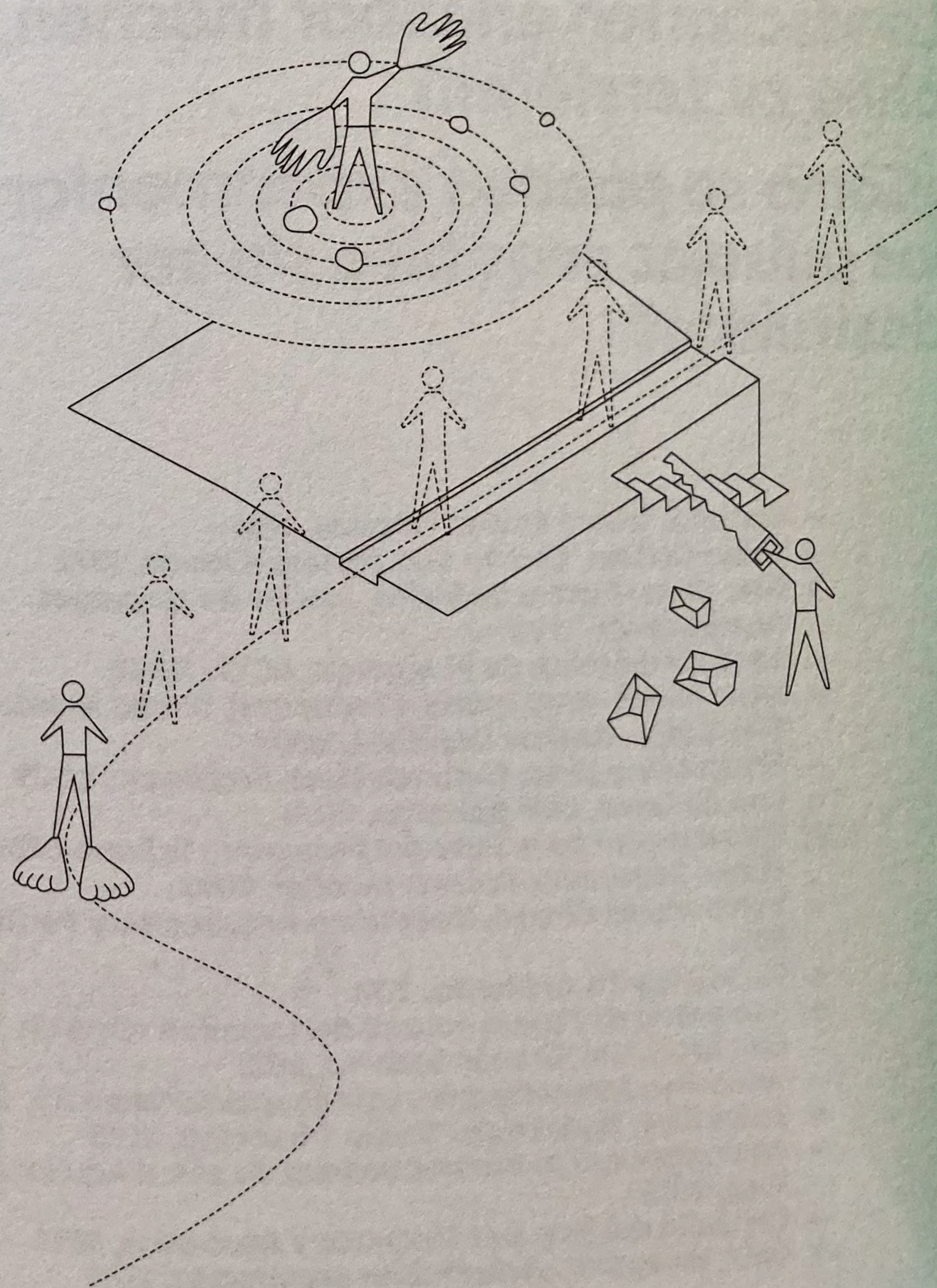

6.9

Which ordering structures help to create a memorable park?

Welche Ordnungsstrukturen helfen, den Park zu erinnern?

¿Qué patrones de orden ayudan a lograr un parque memorable?

- Vaux-le-Vicomte, André Le Nôtre, 1661
- Chiswick House and Gardens, Richard Boyle + William Kent, 1729
- Villa Noailles, Robert Mallet-Stevens + Gabriel Guévrékian, 1927
- Miller House and Garden, Eero Saarinen + Dan Kiley, 1957
- Bagel Garden, Martha Schwartz, 1979
- Parc de la Villette (Competition Entry), OMA, 1982
- Parc de la Villette, Bernard Tschumi, 1998
- Interpolis Garden, West 8, 1998
- Landesgartenschau Eberswalde, Topotek 1, 2002
- HTO Park, Janet Rosenberg & Associates, 2008
- Park of Luna, HOSPER + DRFTWD, 2008
- Sugar Beach, Claude Cormier + Associés, 2011
- Parque Bicentenario de la Infancia, Elemental, 2012
- Novartis Physic Garden, Thorbjörn Andersson + Sweco Architects, 2012
- Buitenschot Park, H+N+S Architects, 2013
- PIXELAND, 100architects, 2019

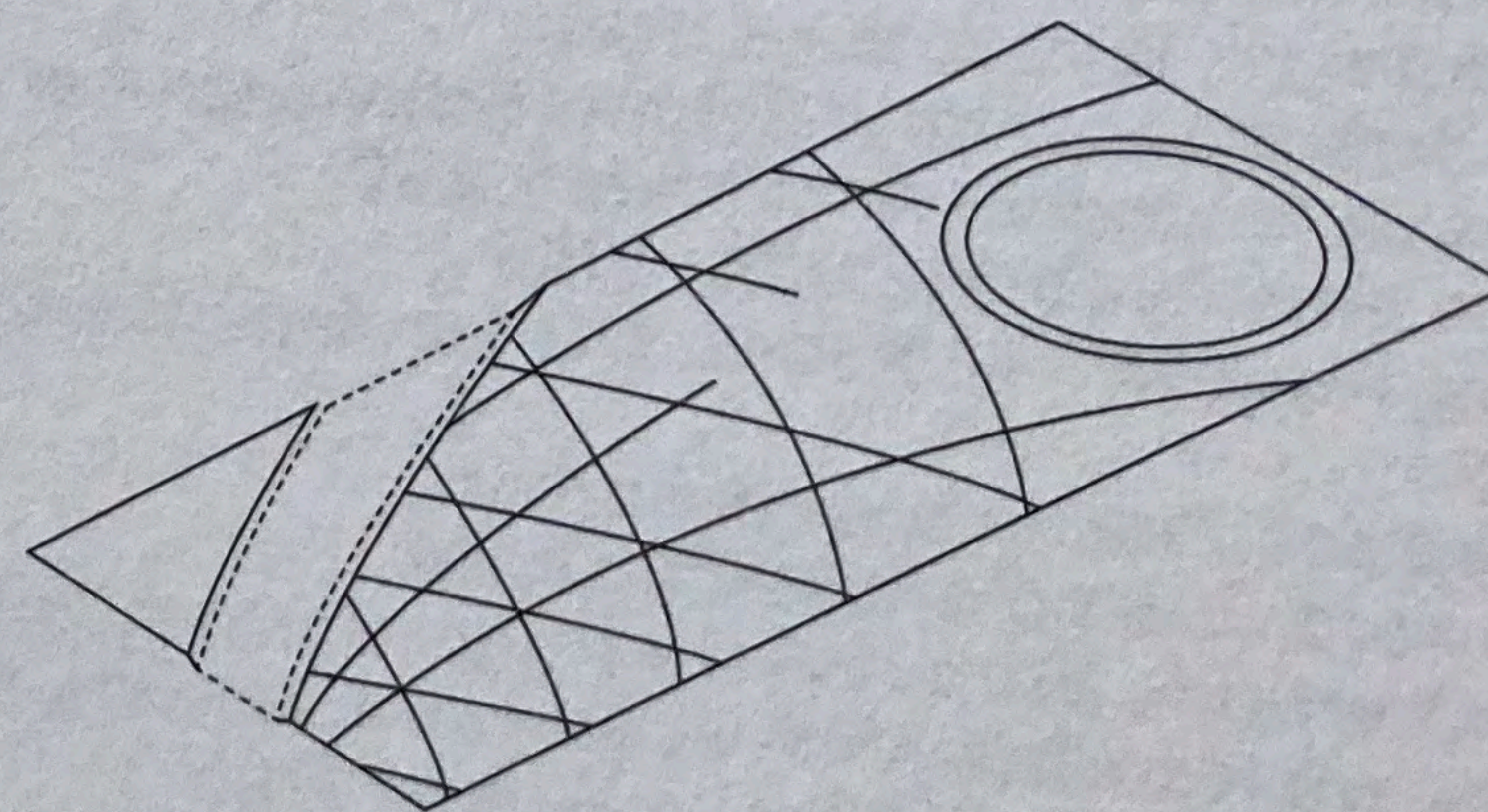
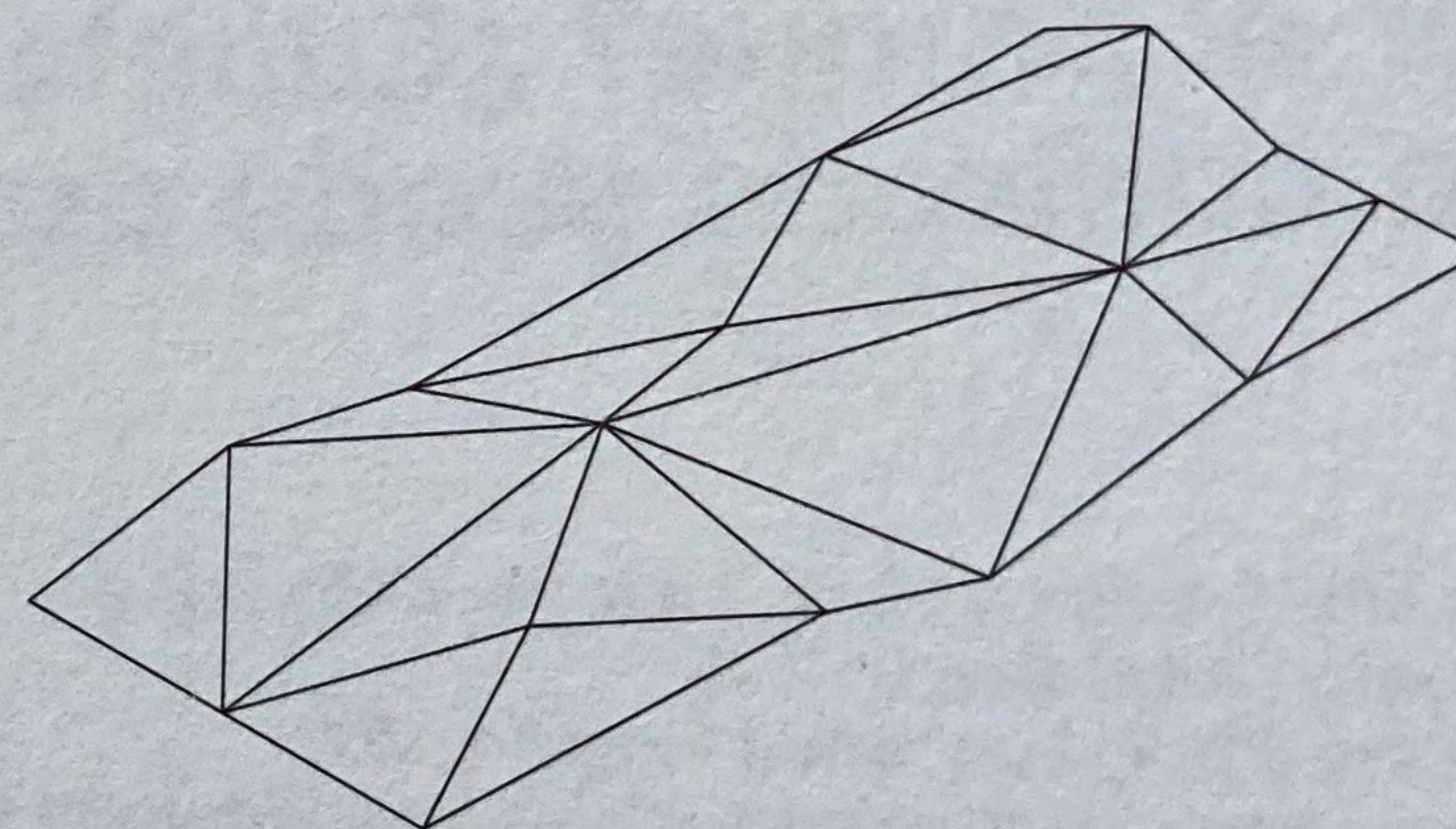
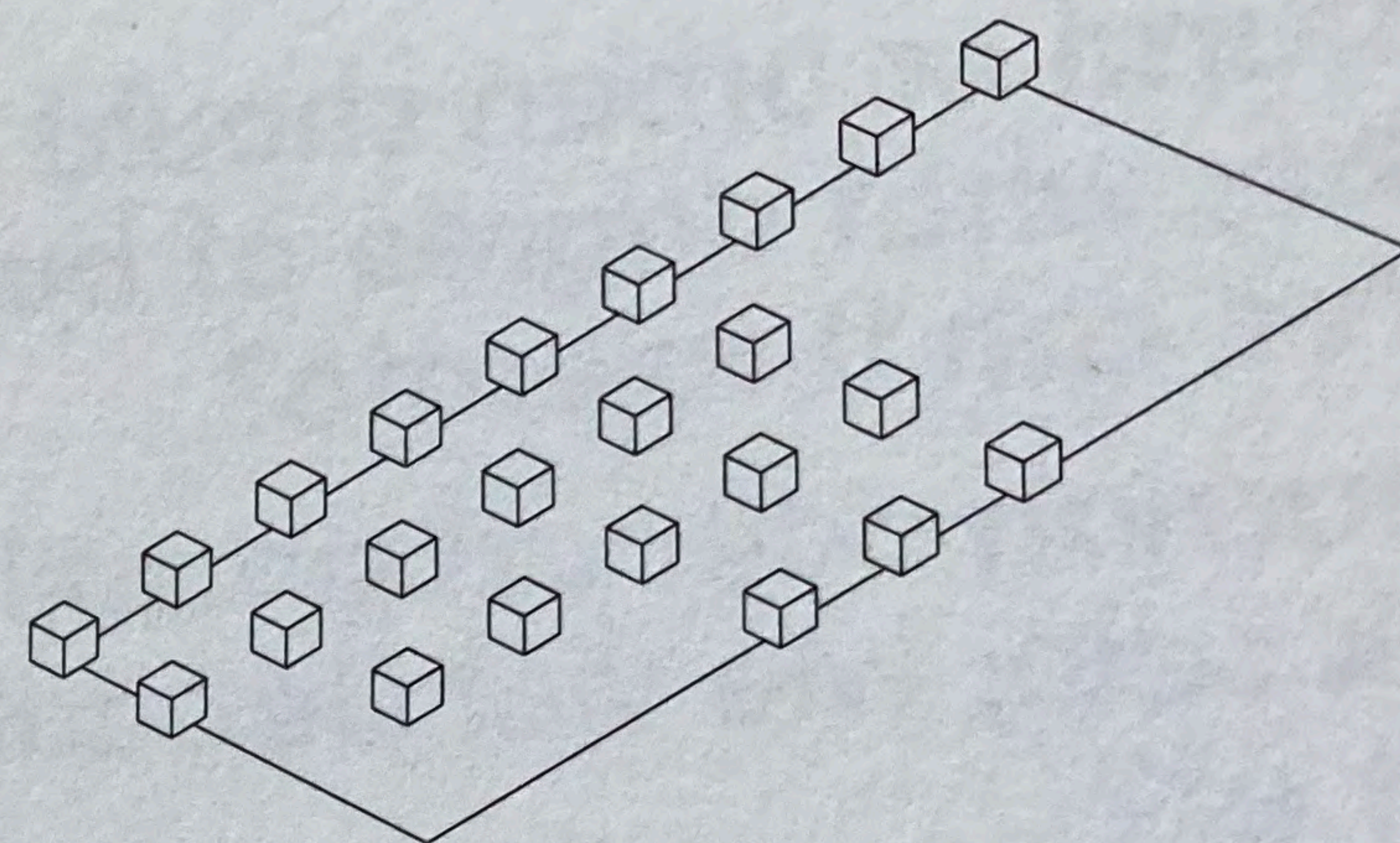

1.6

How does the level of the park relate to its surroundings?

Auf welchem Höhenniveau liegt der Park zum Umfeld?

¿A qué altura se encuentra el parque en relación con su entorno?

- Kings Park, John Oldham, 1831
- Parc Güell, Antoni Gaudí, 1914
- Parc de Montjuïc, Jean Claude Nicolas Forestier, Nicolau Maria Rubió i Tudurí, 1929
- Sunken Garden, Isamu Noguchi, 1961
- Skyline Park, Lawrence Halprin, 1970
- Parc de la Creueta del Coll, MBM + Eduardo Chillida, 1987
- High Line, James Corner Field Operations + Piet Oudolf + Diller Scofidio + Renfro, 2009
- 11 Miyashita Park, Atelier Bow-Wow, 2010
- Estonian Road Museum, Salto Architects, 2010
- Parque Cultural Valparaíso, HLPS, 2011
- Minghu Wetland Park, Turenscape, 2012
- Parque Bicentenario de la Infancia, Elemental, 2012
- Turner Temple Place of Remembrance, Auböck + Kárász + Andraschek, Lobnig, 2012
- 12 Park am Gleisdreieck, Atelier LOIDL, 2014
- Parc de Boulogne-Billancourt, Agence Ter, 2017

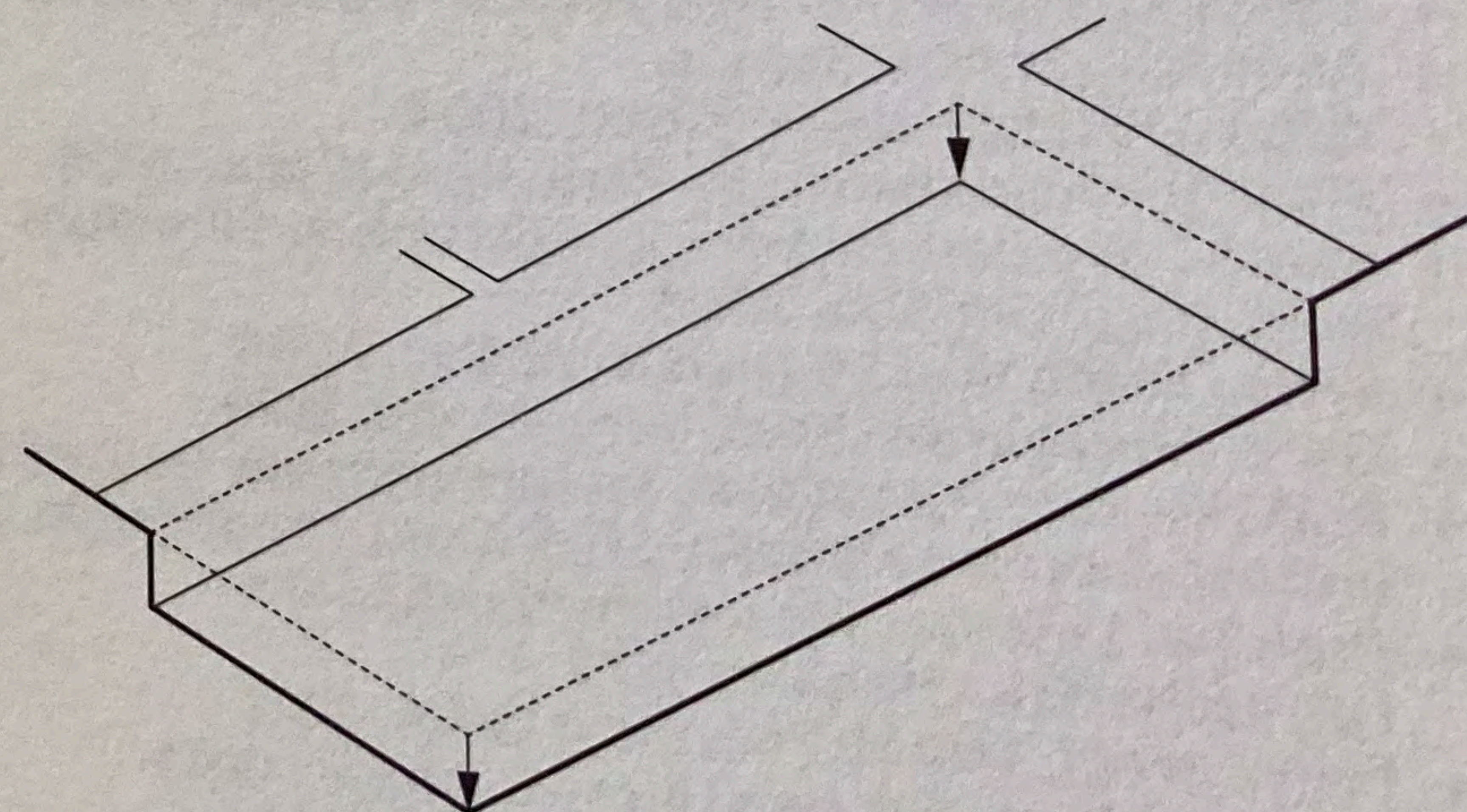
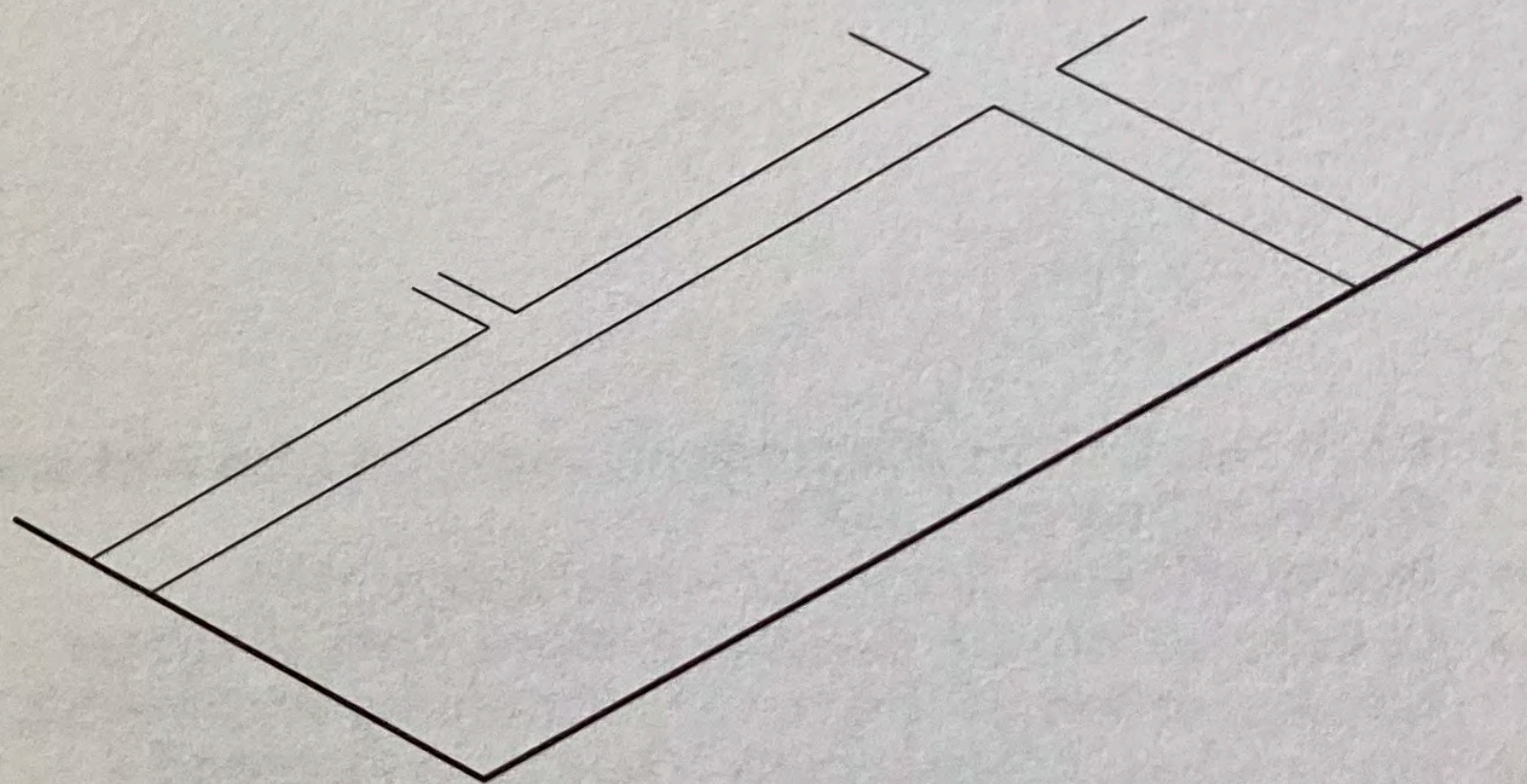
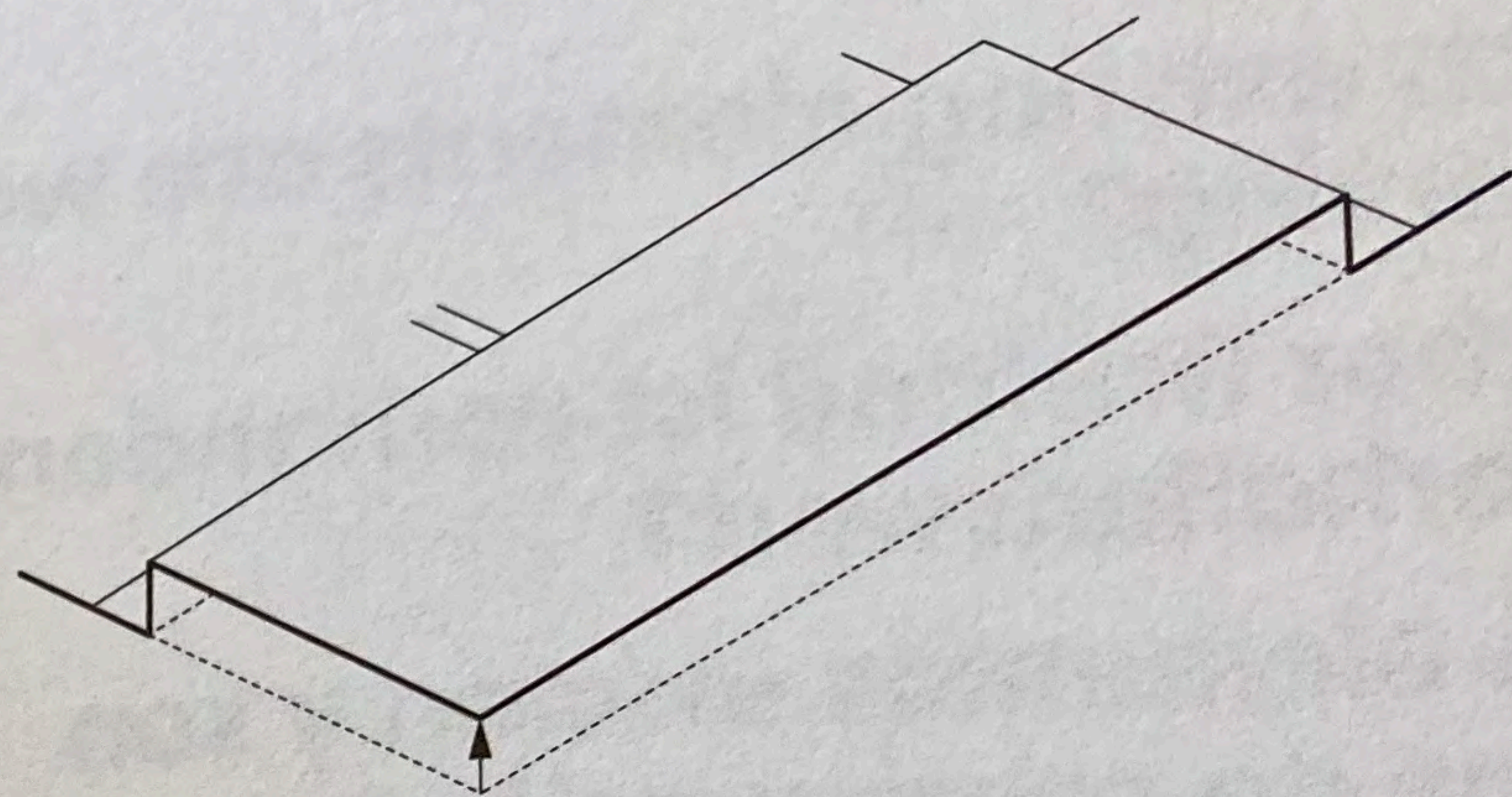

How can one foster new participatory forms and ideas for using a park?

Wir können neue partizipative Nutzungsideen und -formen gefördert werden?

¿Cómo pueden promoverse nuevas ideas y formas de uso participativas?

- Amsterdamse Bos, Cornelis van Eesteren + Jakoba Mulder, 1930
- Park Fiction, Cathy Skene, Christoph Schäfer + arbos, 1997-
- Downsviaw Park, OMA + Bruce Mau, 2000
- Lene-Voigt-Park, Büro Kiefer, 2004
- Jardins d'Eole, Atelier Corajoud, 2006
- 400qm Dessau, Heike Brückner / Planungswerkstatt Stadumbau, 2007
- Normand Park, KLA, 2008
- Sandgrund Park, Thorbjörn Andersson, 2010
- Parkpioniere Tempelhof, Ideenwerkstatt Tempelhof (mbup, raumlaborberlin, Studio UC), Stadt Berlin, 2011
- Interkultureller Stadtpark, lohrer.hochrein, 2012
- Park of the Docks, Agence Ter, 2013
- Luchtsingel en Pompenburg Park, ZUS, 2014
- Superkilen, BIG + Superflex + Topotek 1, 2014
- 12 Park am Gleisdreieck, Atelier LOIDL, 2014
- Kleiner Tiergarten / Ottopark, Latz + Partner
- Landschaftsarchitektur Stadtplanung Architektur, 2016
- Watertoren Park, Karres en Brands, 2018

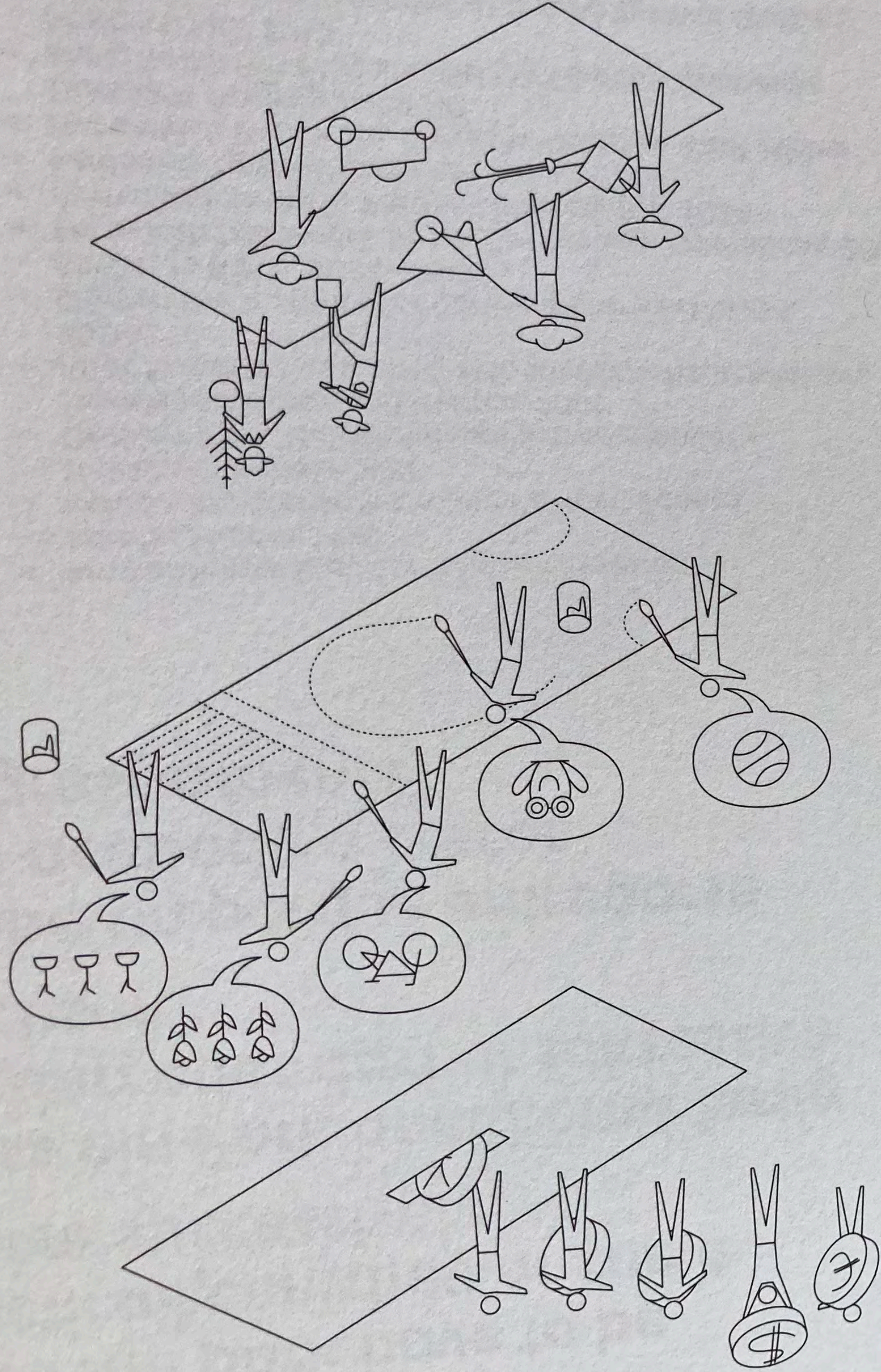

2.8

How can individual interventions be coordinated as a coherent whole?

Wie können einzelne Interventionen zu einem Ganzen entwickelt werden?

¿Cómo pueden integrarse las intervenciones individuales para formar un todo?

- Gutspark Dorf Zuetzen, Peter Joseph Lenné, 1832
- 01 Verschönerungs-Plan der Umgebung von Potsdam, Peter Joseph Lenné, 1833
- National Tourist Routes Norway, 1955–
- Museumsinsel Hombroich, Bernhard Korte + Erwin Heerich, 1993
- 05 Barnimer Feldmark, Atelier LOIDL, Plancontext, Schirmer und Kernbach, 2001
- Salinas Pools Project, Gomes da Silva, 2003
- Le Sentier des Ogres, Alep, 2007
- 09 Plan maestro de la Ruta del Peregrino, Tatiana Bilbao, Derek Dellekamp, Rozana Montiel, 2010
- Landmarks for Fogo, Saunders Architecture, 2013–
- 11 UNESCO Weltkulturerbe Kloster Lorsch, Topotek 1, 2014
- Ca' Corniani Landscape Enhancement, LAND, 2014–
- :terra nova BiosphärenBand, bbz landschaftsarchitekten + Ernst Scharf, 2015
- Chateau La Coste, Ai Weiwei + Jean Nouvel, Renzo Piano, Tadao Ando, 2017

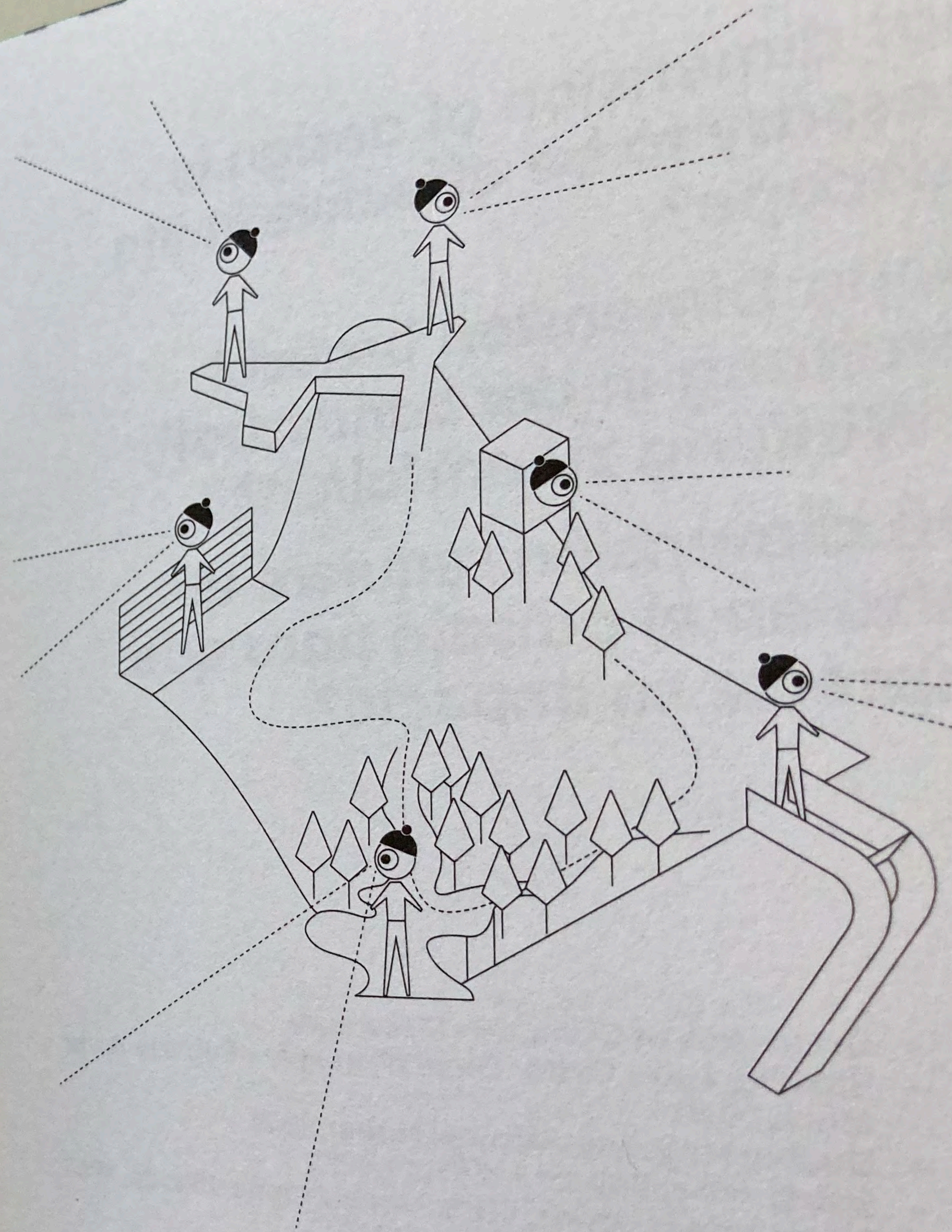

2.7

How can parks be created when space is limited?

Wie können Parks bei Flächenknappheit entwickelt werden?

¿Cómo pueden crearse parques en áreas reducidas?

- Kensington Roof Gardens, Ralph Hancock, 1938
- 02 Jim Ellis Freeway Park, Lawrence Halprin + Angela Danadjieva, 1967
- 03 Paley Park, Zion Breen Richardson Associates, 1967
 - Skyline Park, Lawrence Halprin, 1970
 - Parc del Clot, Dani Freixes, Vicente Miranda, 1986
 - Moll de la Fusta, Manuel de Solà-Morales, 1987
 - Park Atlantique, François Brun, Michel Péna, 1994
 - Jardin du Carrousel, Jacques Wirtz, Louis Benech, Pascal Cribier, 1997
 - Park Fiction, Cathy Skene, Christoph Schäfer + arbos, 1997 -
- 06 MFO-Park, Planergemeinschaft Burckhardtpartner / Raderschall, 2001
 - Flughafen München Terminal 2 Tiefgarage, Rainer Schmidt Landschaftsarchitekten + Stadtplaner, 2003
 - Square Vinet, MDP Michel Desvigne Paysagiste, 2005
 - A8erna, NL Architects, 2006
 - Victor Civita Park, Benedito Abbud, 2008
 - High Line, James Corner Field Operations + Piet Oudolf + Diller Scofidio + Renfro, 2009
- 11 Miyashita Park, Atelier Bow-Wow, 2010
 - Toronto Underpass Park, PFS Studio and The Planning Partnership, 2012
 - Sishane Park, SANALarc, 2014
 - Vierhaven Strip, Buro Sant en Co, 2014
 - Rooftop Park Bulwark Sint Jan, OSLO Ontwerp Stedelijke en Landschappelijke Omgeving, 2015
 - Jardín Ciudadano, Práctica Arquitectura, 2018

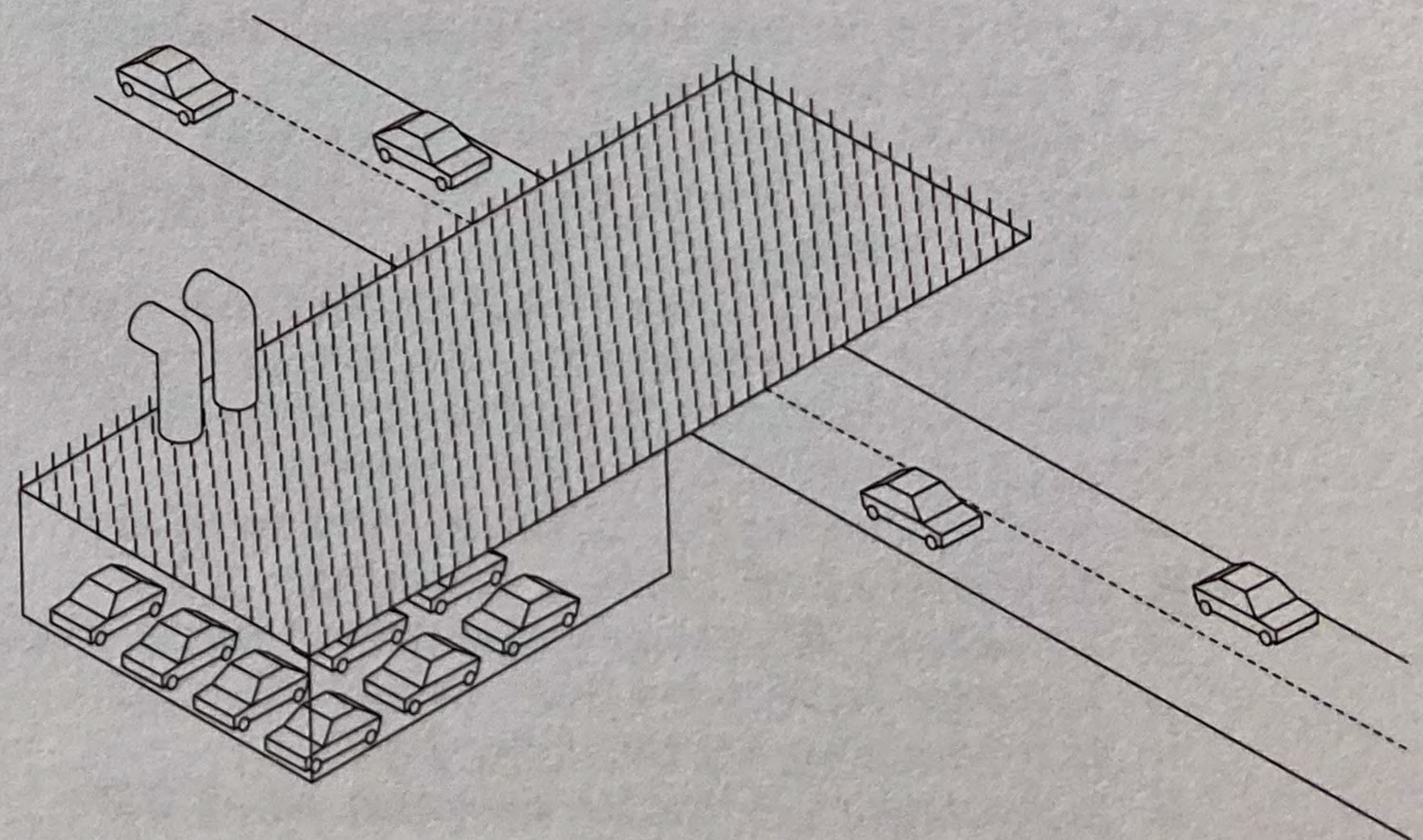
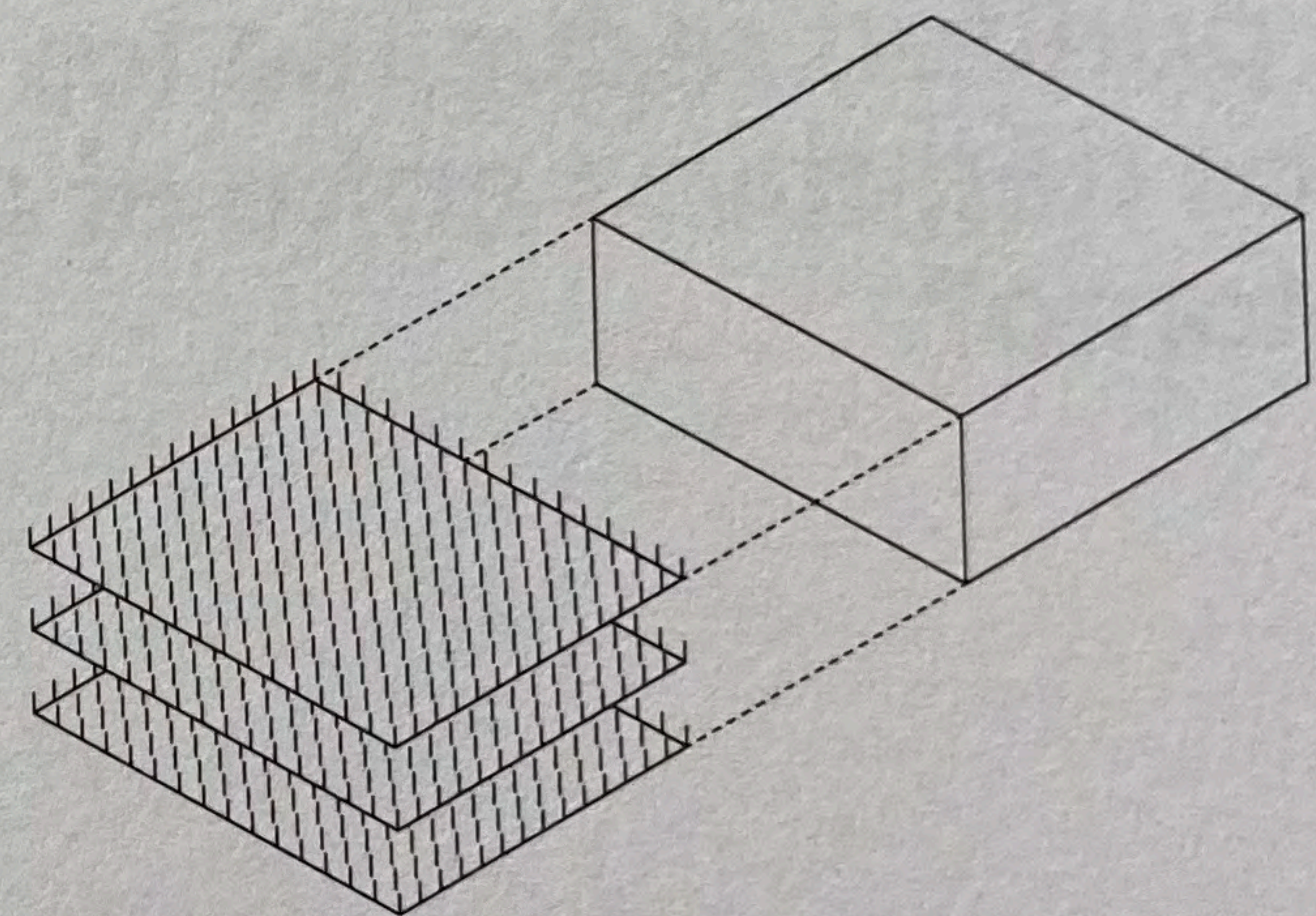
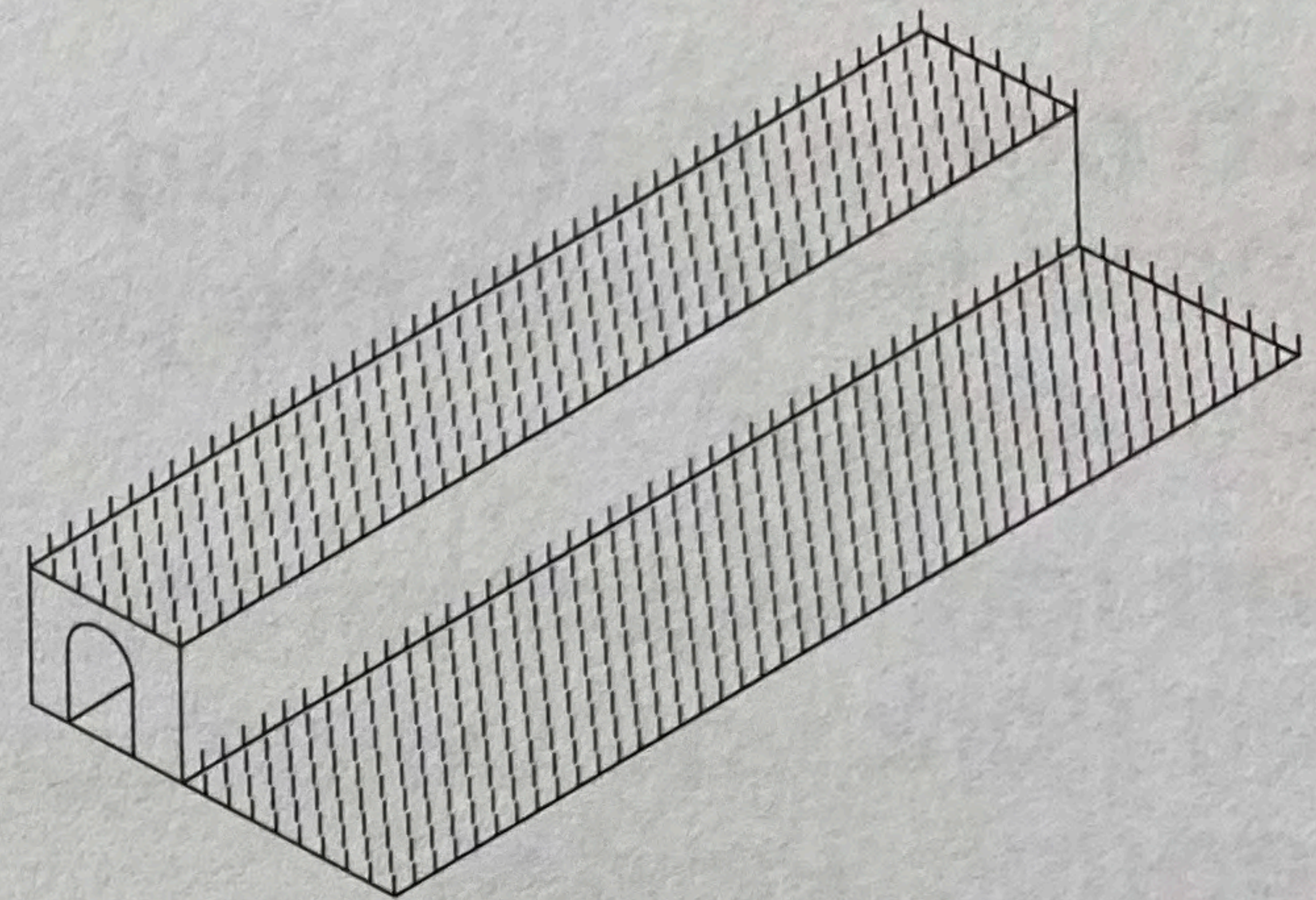

4.2

How can energy be generated within a park?

Wie kann Energiegewinnung in den Park integriert werden?

¿Cómo puede integrarse en el parque la producción de energía?

- Neue Gärten auf dem Dycker Feld, RMP Landschaftsarchitekten, 2002
- 10 Father Collins Park, Fernando Abelleiro + Mauro Romero, 2009
- Solarfeld Gänsdorf, raum + zeit, 2011
- Lizard Log Parklands, Mac Gregor Coxall, 2011
- SWING, Moradavaga, 2012
- Energy Carousel, Ecosistema Urbano, 2012
- Ecological Energy Network, LOLA, 2012
- Energieberg Georgswerder, Häfner / Jiménez, 2013
- Martin Luther King Park, Jacqueline Osty, 2014
- Lochore Meadows Country Park, Greenspace Scotland, 2017

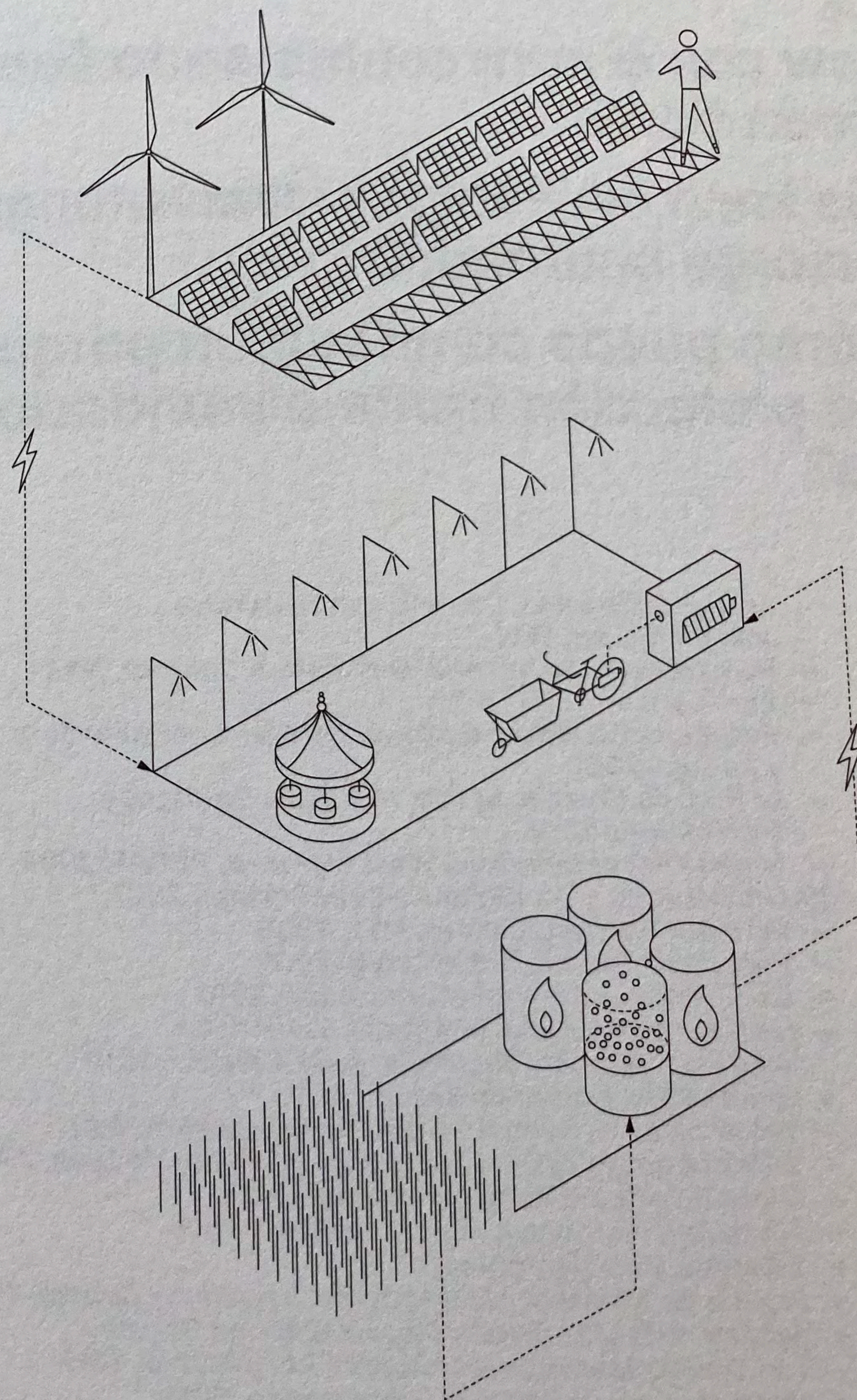

6.5

How can form create identity?

Wie kann Form Identität schaffen?

¿Cómo puede crearse identidad a partir de la forma?

- **04** Geometrical Garden, Carl Theodor Sørensen, 1945–1984
 - Olympiapark, Günther Grzimek + Behnisch & Partner, Frei Otto, 1972
 - Garden of Cosmic Speculation, Charles Jencks, 1990
 - Parc de l'Estació del Nord, ARRIOLA&FIOL arquitectes + Beverly Pepper, 1991
 - Tilla-Durieux-Park, DS landschapsarchitecten, 2003
 - Allerpark, Büro Kiefer, 2004
 - Tejo and Trancão Park, Hargreaves Associates, João Nunes, 2004
- **08** Swiss Cottage Open Space, Gustafson Porter + Bowman, 2006
 - Parc Central de Nou Barris, ARRIOLA&FIOL arquitectes, 2007
 - Rheinpark, Atelier LOIDL, 2010
 - City Dune, SLA, 2010
 - Buitenschot Park, H+N+S Architects, 2013
 - Baakenpark, Atelier LOIDL, 2018

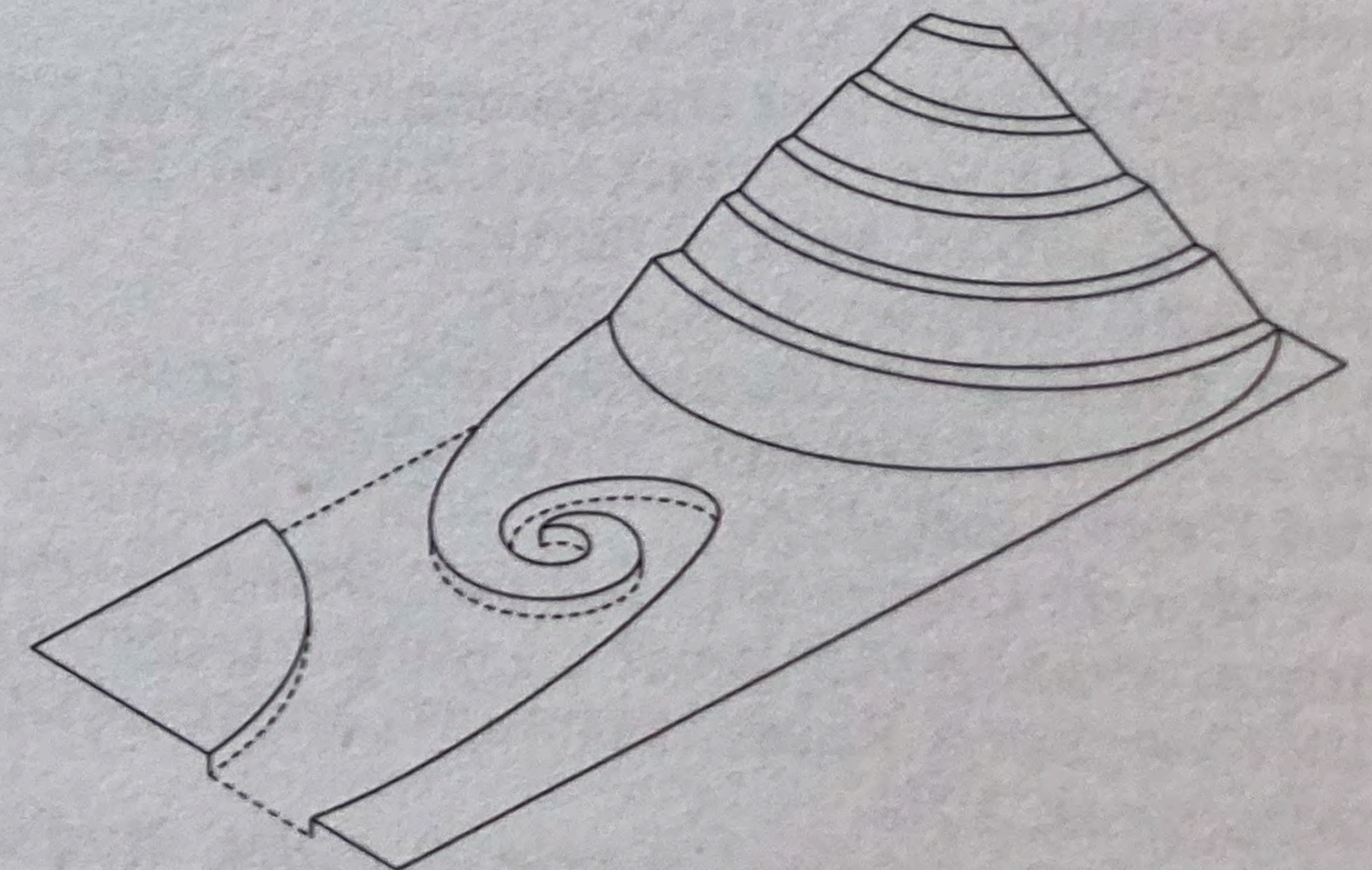
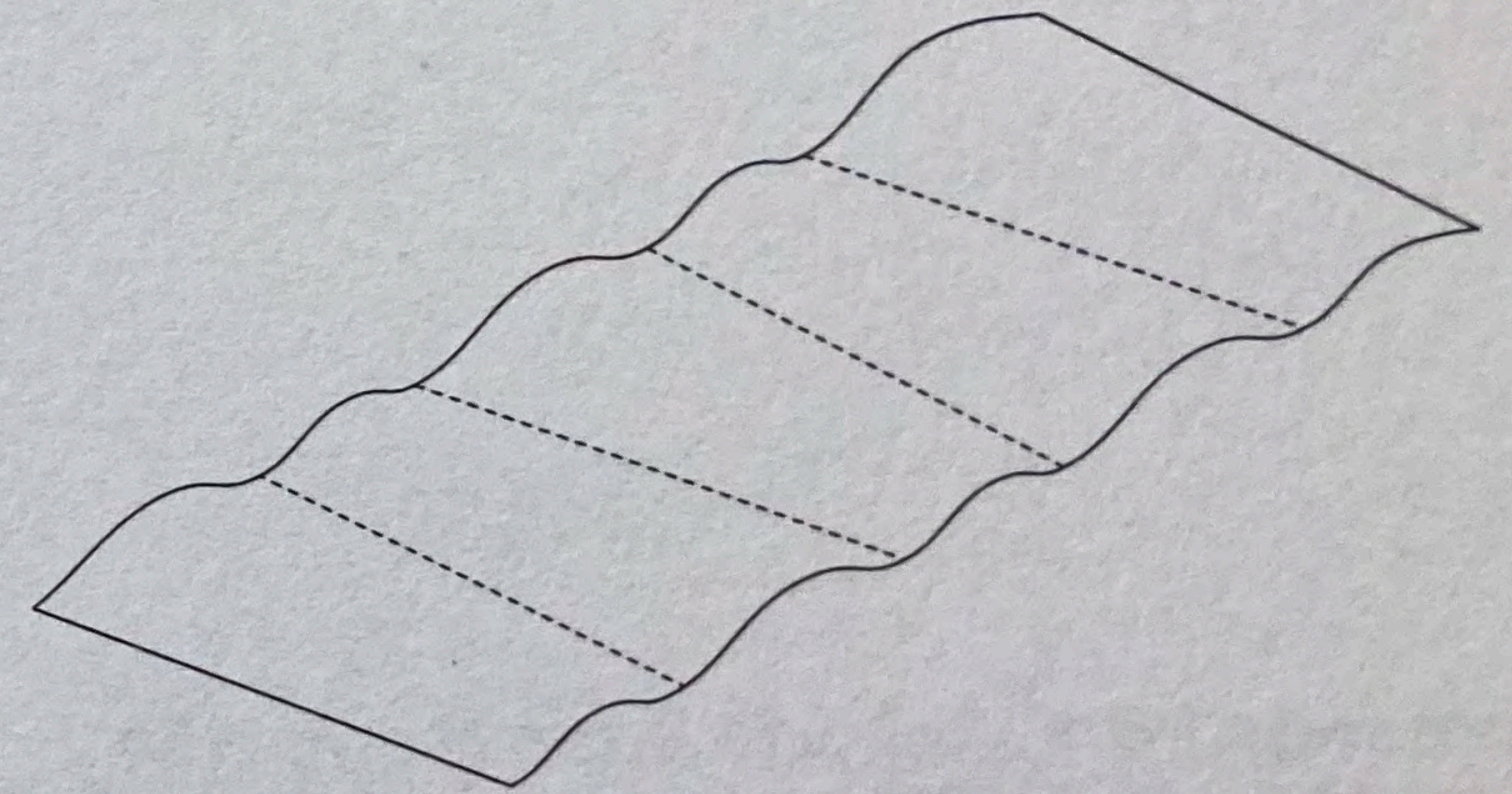
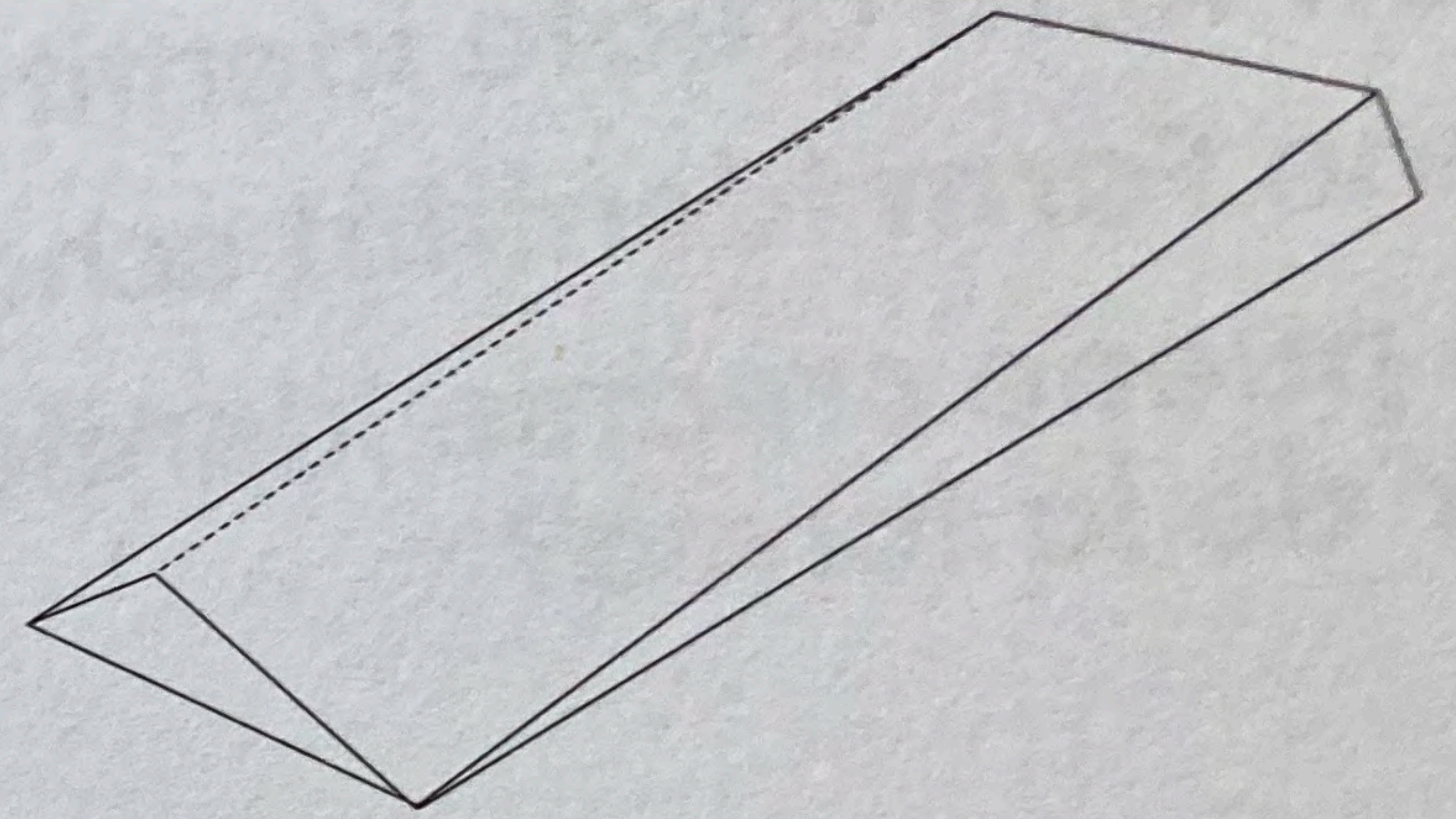

4.1

How can a park be designed in a way to conserve resources?

Wie kann ein Park ressourcenschonend realisiert werden?

¿Cómo puede ejecutarse un parque que respete los recursos?

- Park Branitz, Hermann Fürst von Pückler-Muskau, 1845
- Parc Güell, Antoni Gaudí, 1914
- Bagel Garden, Martha Schwartz, 1979
- Parc du Sausset, Atelier Corajoud, 1981
- Garden of Cosmic Speculation, Charles Jencks, 1990
- Landschaftspark Duisburg-Nord, Latz + Partner
Landschaftsarchitektur Stadtplanung Architektur, 1999
- Alter Flugplatz Bonames, GTL Landschaftsarchitekten, 2004
- Parc de Pedra Tosca, RCR Arquitectes, 2004
- Cultuurpark Westergasfabriek Park, Gustafson Porter + Bowman, 2004
- Hermann-Blankenstein-Park, Büro Kiefer, 2005
- Connecticut Water Treatment Facility,
Michael Van Valkenburgh Associates, 2005
- Le Parc du Chemin de l'île, Mutabilis Landscape
Architecture, 2006
- Parc des Cormailles, Agence Ter, 2006
- 09 Opfikerpark, Büro Kiefer + Hager Partner, 2007
- Victor Civita Park, Benedito Abbud, 2008

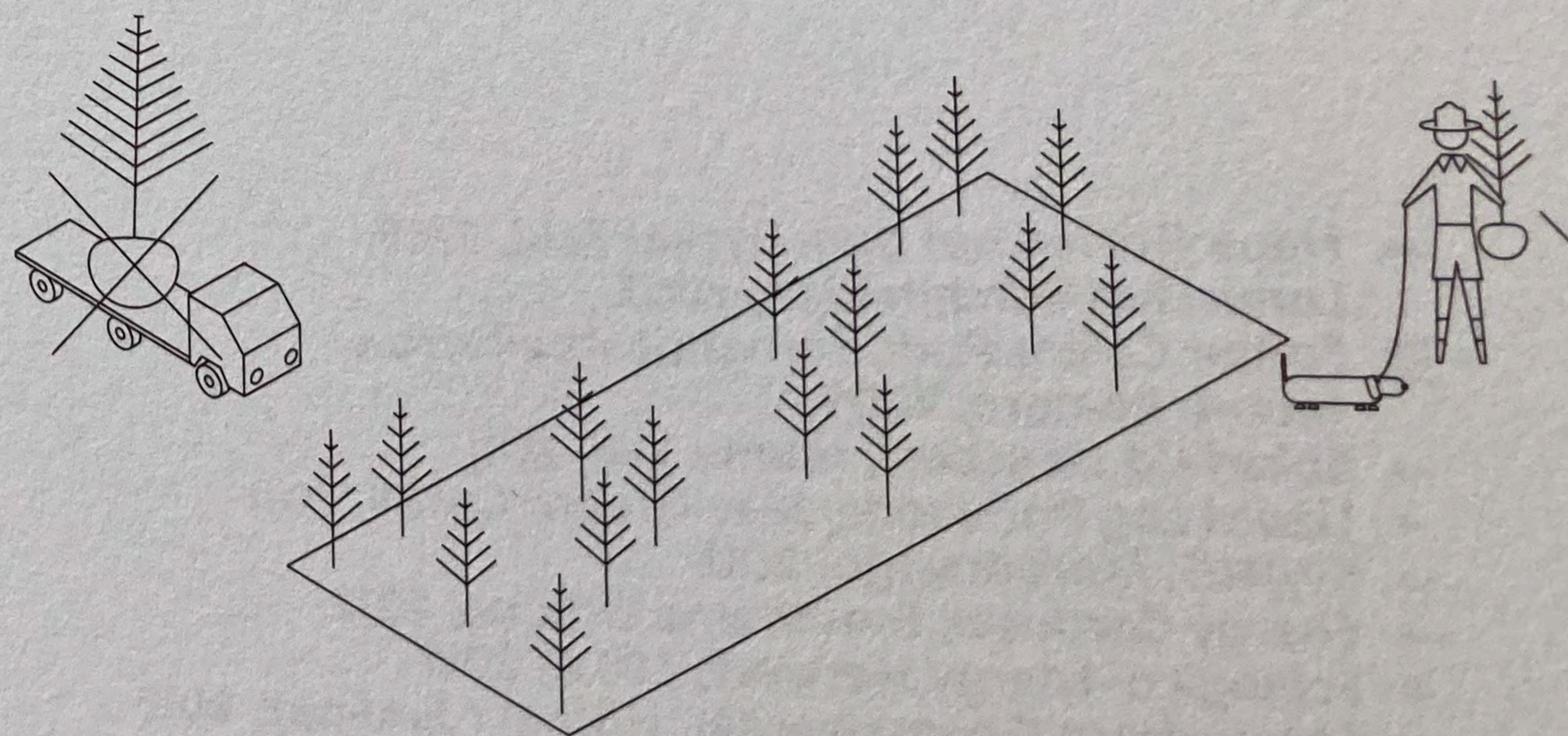
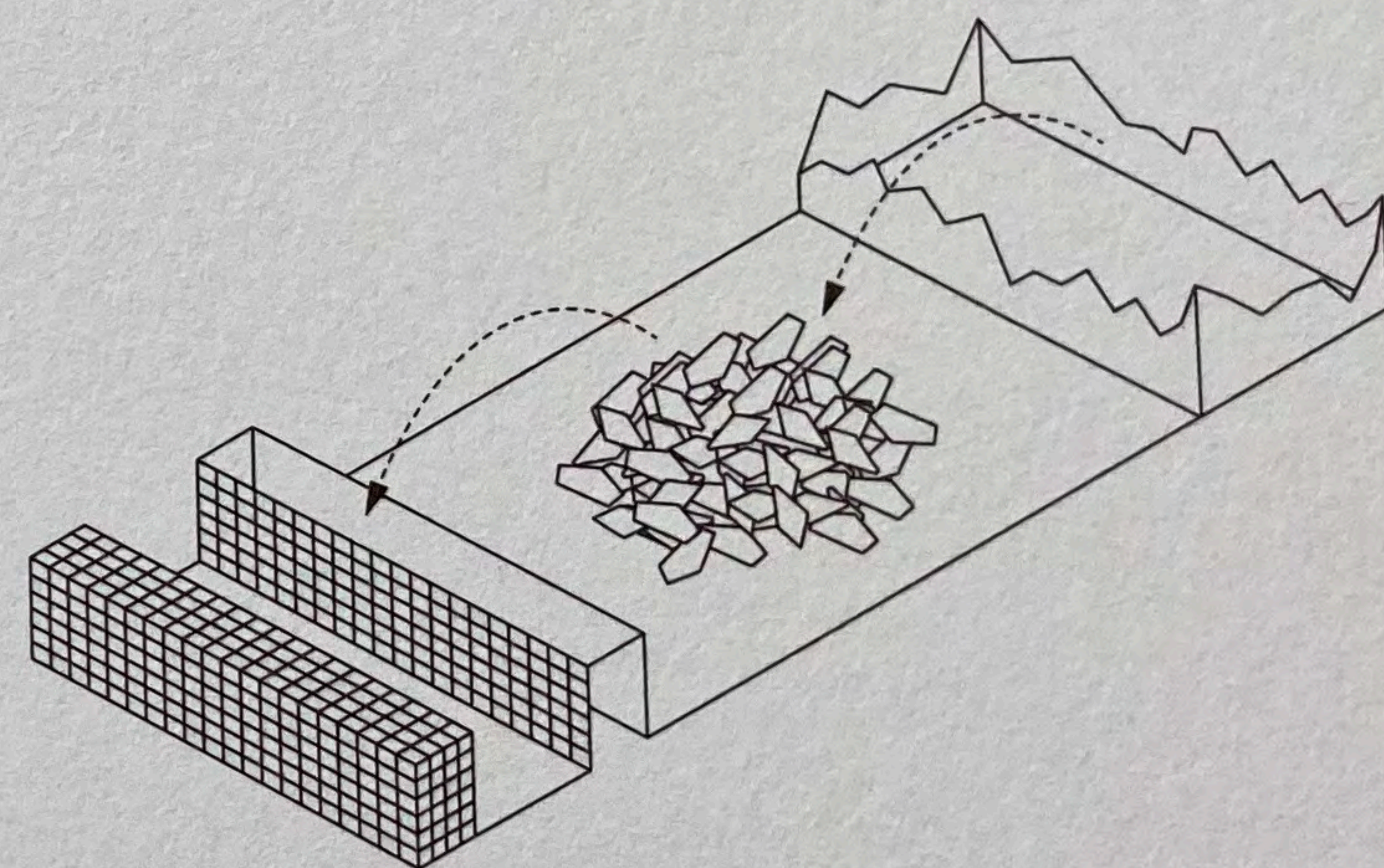
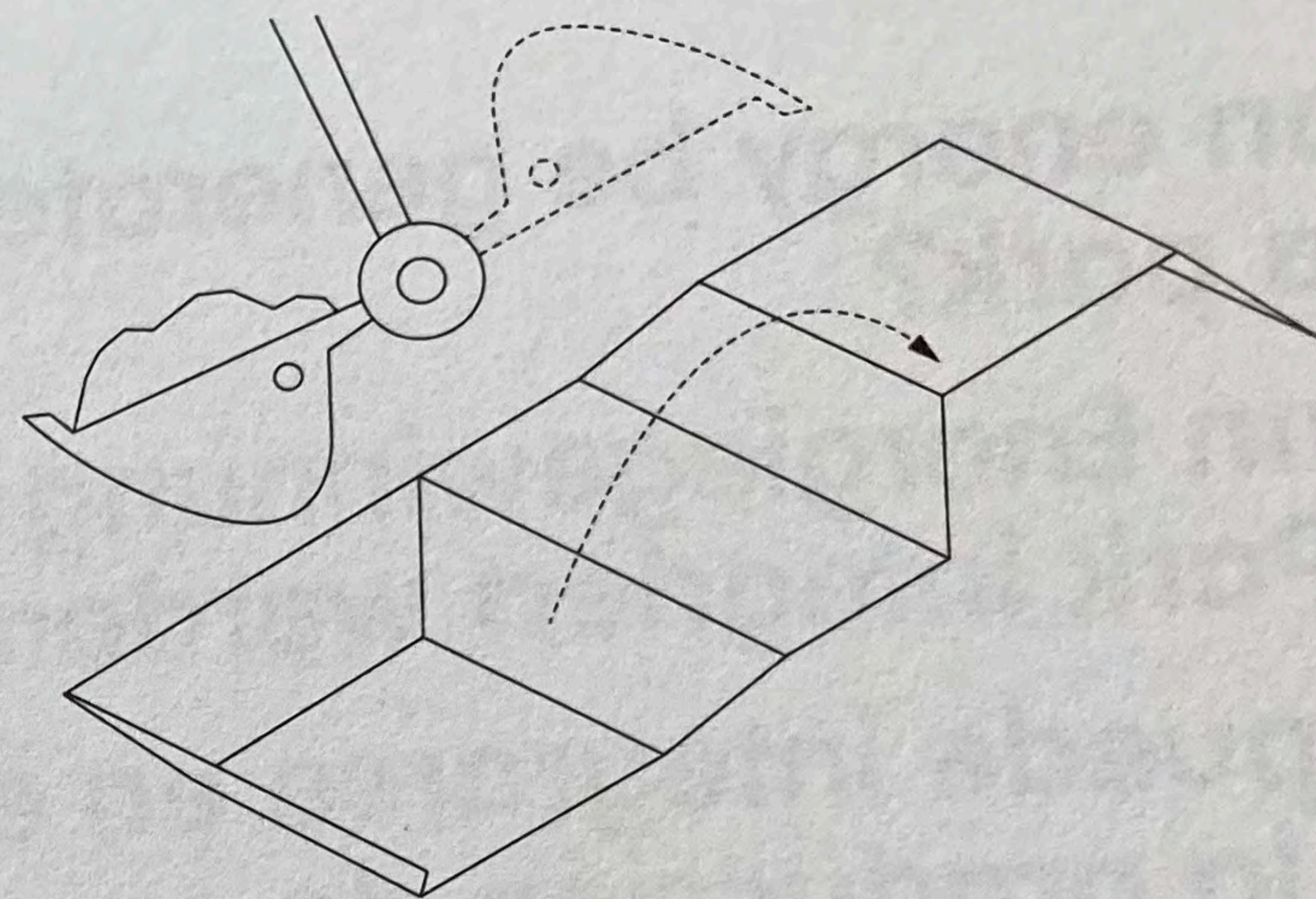

6.7

Which vegetation is able to create distinctive atmospheres?

Welche Vegetation vermag starke Atmosphären zu generieren?

¿Qué vegetación permite la generación de atmósferas impactantes?

- Garden of Saihō-ji, Musō Sosek, 731
- Le Jardin de Claude Monet à Giverny, Claude Monet, 1893–1920
- Jardin de Marqueyssac, Julien de Cervel, 1860
- Wassergarten Pflanzen un Blumen, Karl Plomin, 1935
- 04 Geometrical Garden, Carl Theodor Sørensen, 1945–1984
- Garden Villa Fiorita, Pietro Porcinai, 1958
- 03 Paley Park, Zion Breen Richardson Associates, 1967
- Waterfront Park, Tom McCall, 1978
- Bamboo Garden, Alexandre Chemetoff + Daniel Buren + Bernhard Leitner, 1987
- Gehölzgarten Ripshorst, Martin Diekmann, Irene Lohaus, Peter Carl, 1990
- Topiarys Garten, Dieter Kienast, 1991
- Natur-Park Südgelände, ÖkoCon + Planland + Gruppe Odious, 1999
- Wahlenpark, Dipol Landschaftsarchitekten, 2005
- 07 Landschaftspark Riem, Latitude Nord, 2005
- 08 Swiss Cottage Open Space, Gustafson Porter + Bowman, 2006
- De Nieuwe Ooster, Karres en Brands, 2007
- An Ning Zhuang, Vogt Landschaftsarchitekten + B & E Baumschlager Eberle, 2008
- Houtan Park, Turenscape, 2010
- Sunnylands Center and Garden, James Burnett, 2012
- The Australian Garden, Taylor Cullity Lethlean + Paul Thompson, 2012
- Eda U. Gerstacker Grove, Stoss, 2015

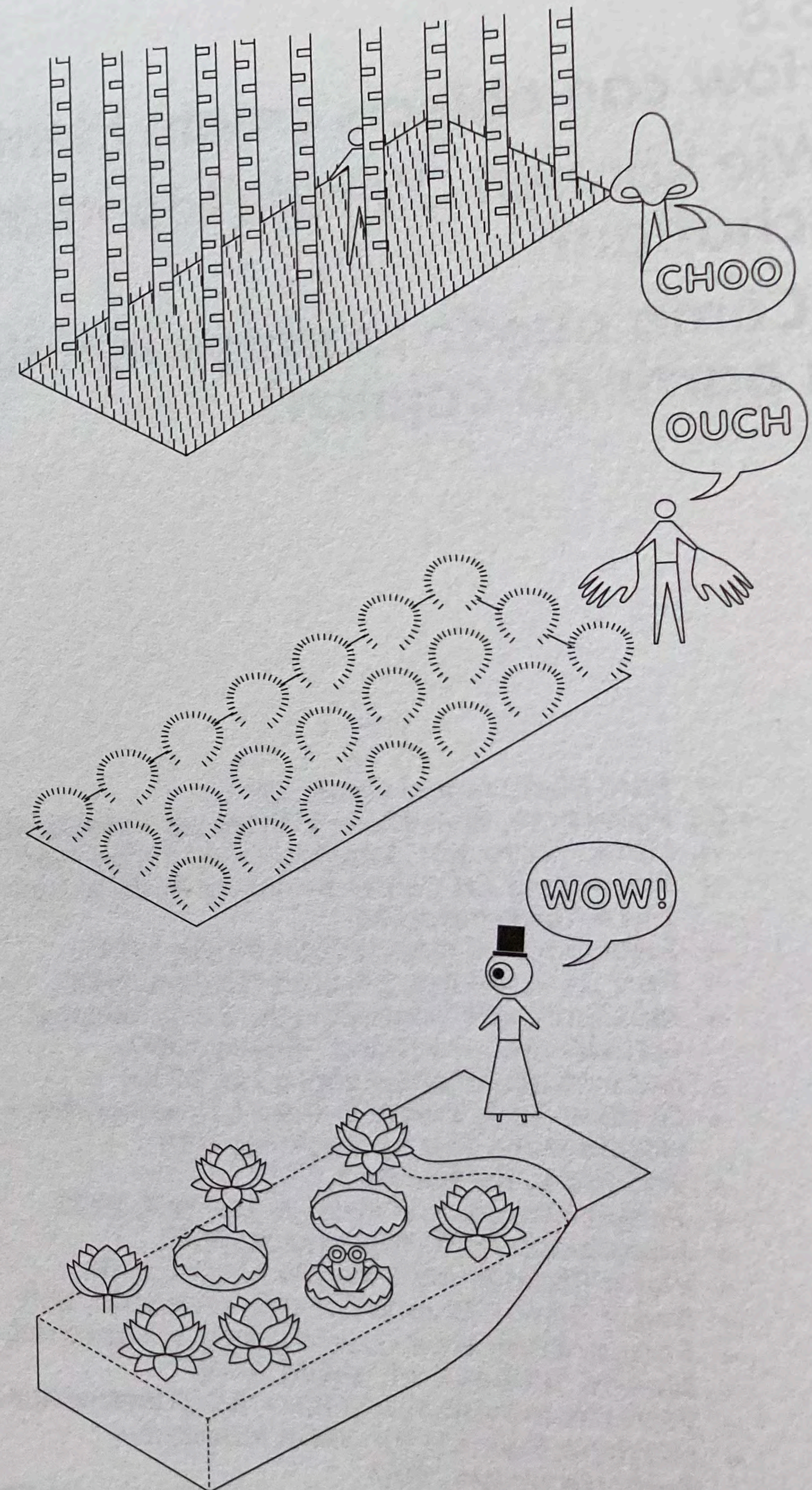

4.10

Which social, ecological and economic consequences are to be expected?

Welche sozialen, ökologischen, ökonomischen Folgen sind zu erwarten?

¿Qué efectos sociales, ecológicos y económicos cabe esperar?

- Future Garden, Helen Mayer Harrison & Newton Harrison, 1996
- Natur-Park Südgelände, ÖkoCon + Planland + Gruppe Odious, 1999
- Parc Agricole, Kamel Louafi, 2000
- Waldpark, Bureau B+B, 2001
- Parc de la Feysine, Ilex paysage + urbanisme, 2001
- Oerliker Park, Zulauf Seippel Schweingruber + Haerle Hubacher Architekten, 2001
- Lene-Voigt-Park, Büro Kiefer, 2004
- Cultuurpark Westergasfabriek Park, Gustafson Porter + Bowman, 2004
- South Lake Central Park, Landscape Architecture at Beijing Tsinghua, 2008
- The Other Site, mosbach paysagistes, 2008
- High Line, James Corner Field Operations + Piet Oudolf + Diller Scofidio + Renfro, 2009
- 10 Father Collins Park, Fernando Abelleiro + Mauro Romero, 2009
- Houtan Park, Turenscape, 2010
- Shibo Park, NITA Design Group, 2010

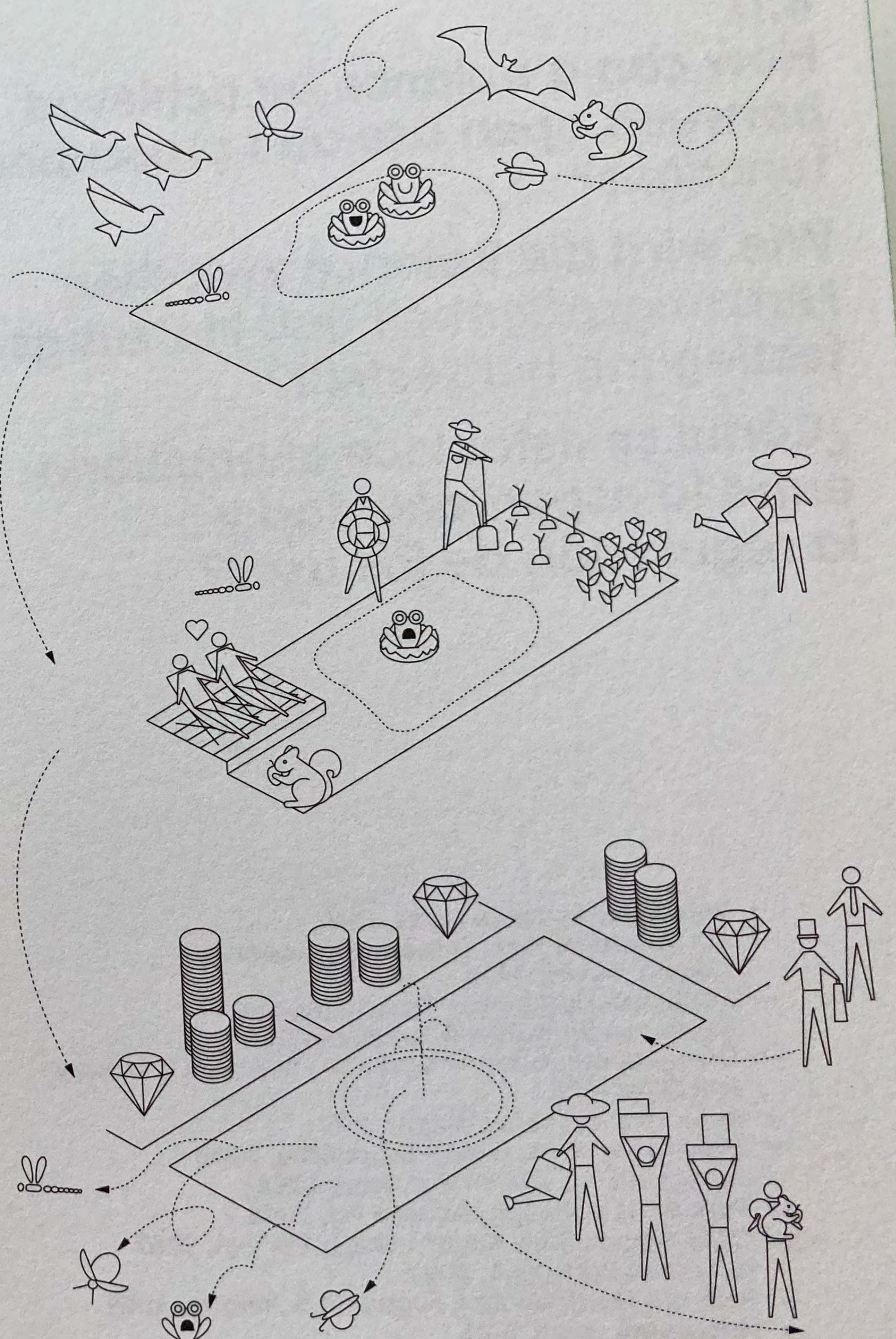

7.3

Does it have different levels?

Gibt es mehrere Höhenebenen?

¿Existen diferencias de nivel?

- Parc Güell, Antoni Gaudí, 1914
- Parc de Montjuïc, Jean Claude Nicolas Forestier, Nicolau Maria Rubió i Tudurí, 1929
- 01 Volkspark Rehberge, Erwin Barth + Rudolf Germer, 1929
- 03 Paley Park, Zion Breen Richardson Associates, 1967
- Irchelpark, Atelier Stern und Partner, Eduard Neuenschwander, 1986
- Parc de la Creueta del Coll, MBM + Eduardo Chillida, 1987
- Thames Barrier Park, Groupe Signes, 2000
- 06 MFO-Park, Planergemeinschaft Burckhardtpartner / Raderschall, 2001
- Tilla-Durieux-Park, DS landschapsarchitecten, 2003
- Volcano Pavilion and Water Gardens S. Vincente, Global + Paulo David, 2004
- Carlebach Park, Levin Monsigny Landschaftsarchitekten, 2005
- Jardins d'Éole, Atelier Corajoud, 2006
- Parque Sa Riera, Ravetllat Ribas, 2007
- Parc de l'Île aux planches, HYL, 2008
- Sugar Beach, Claude Cormier + Associés, 2011
- Parque Bicentenario de la Infancia, Elemental, 2012
- 12 Park am Gleisdreieck, Atelier LOIDL, 2014
- Rooftop Park Bulwark Sint Jan, OSLO Ontwerp Stedelijke en Landschappelijke Omgeving, 2015
- Landesgartenschau Landau, A24 Landschaft, 2015

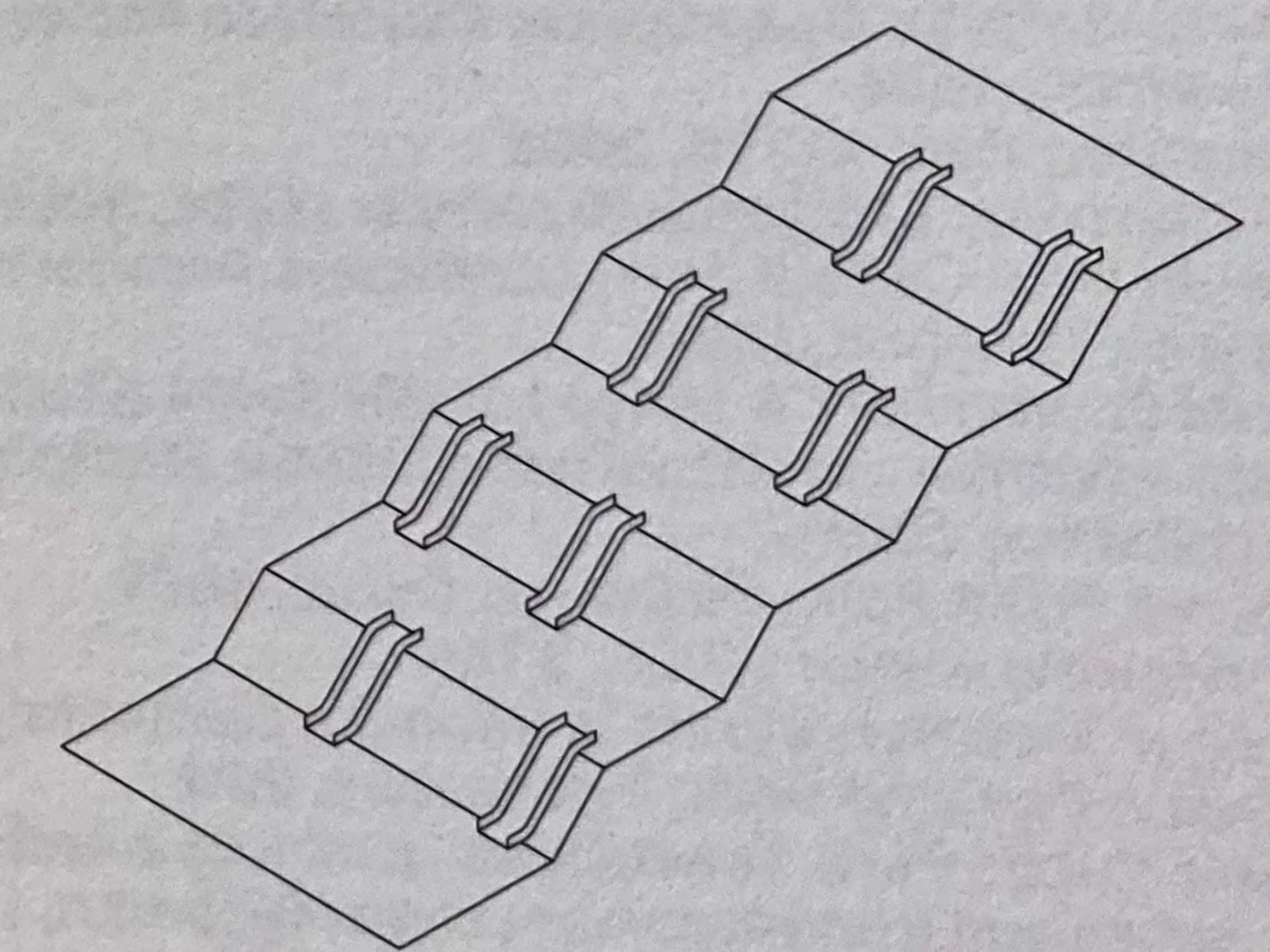
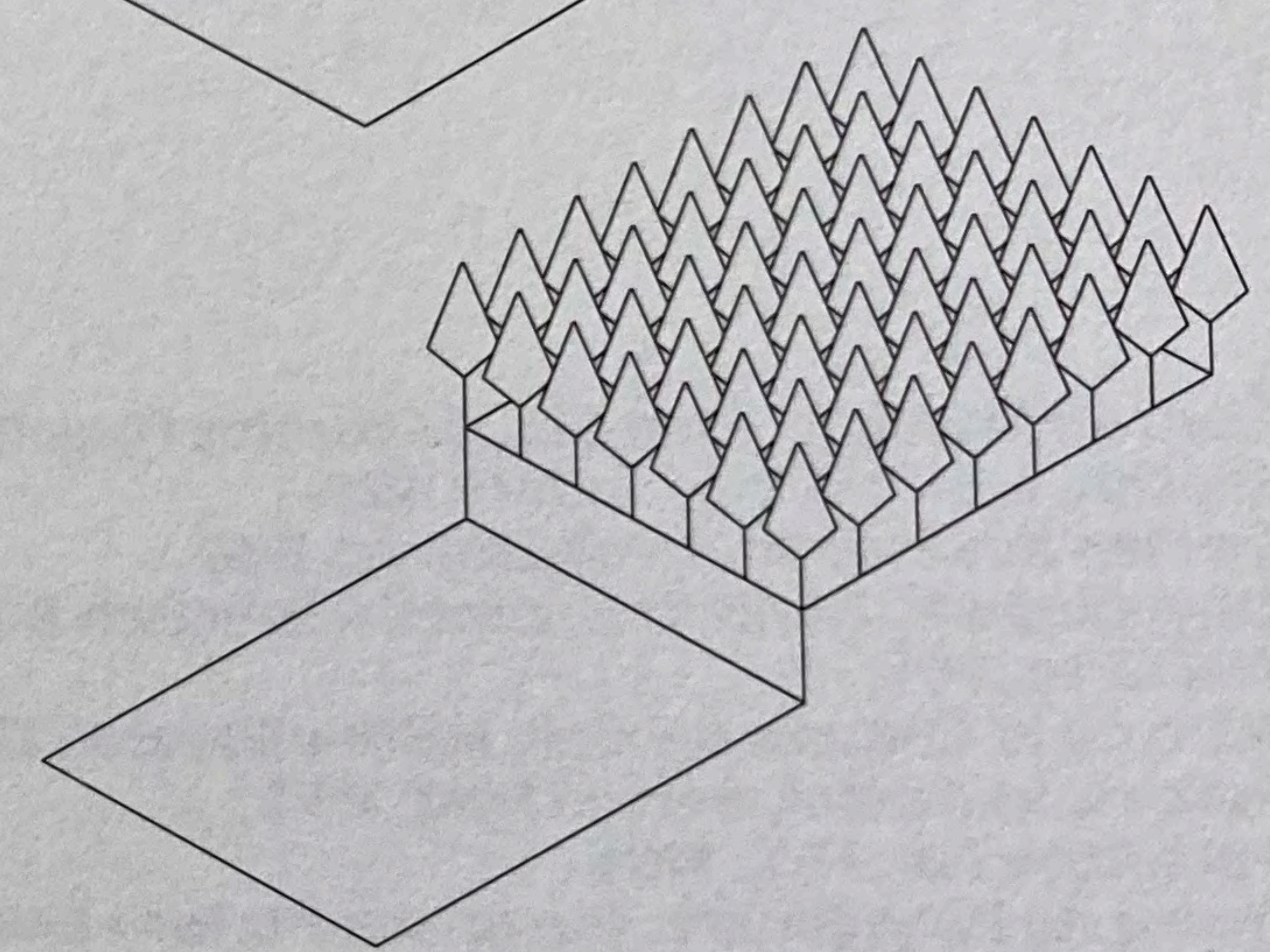
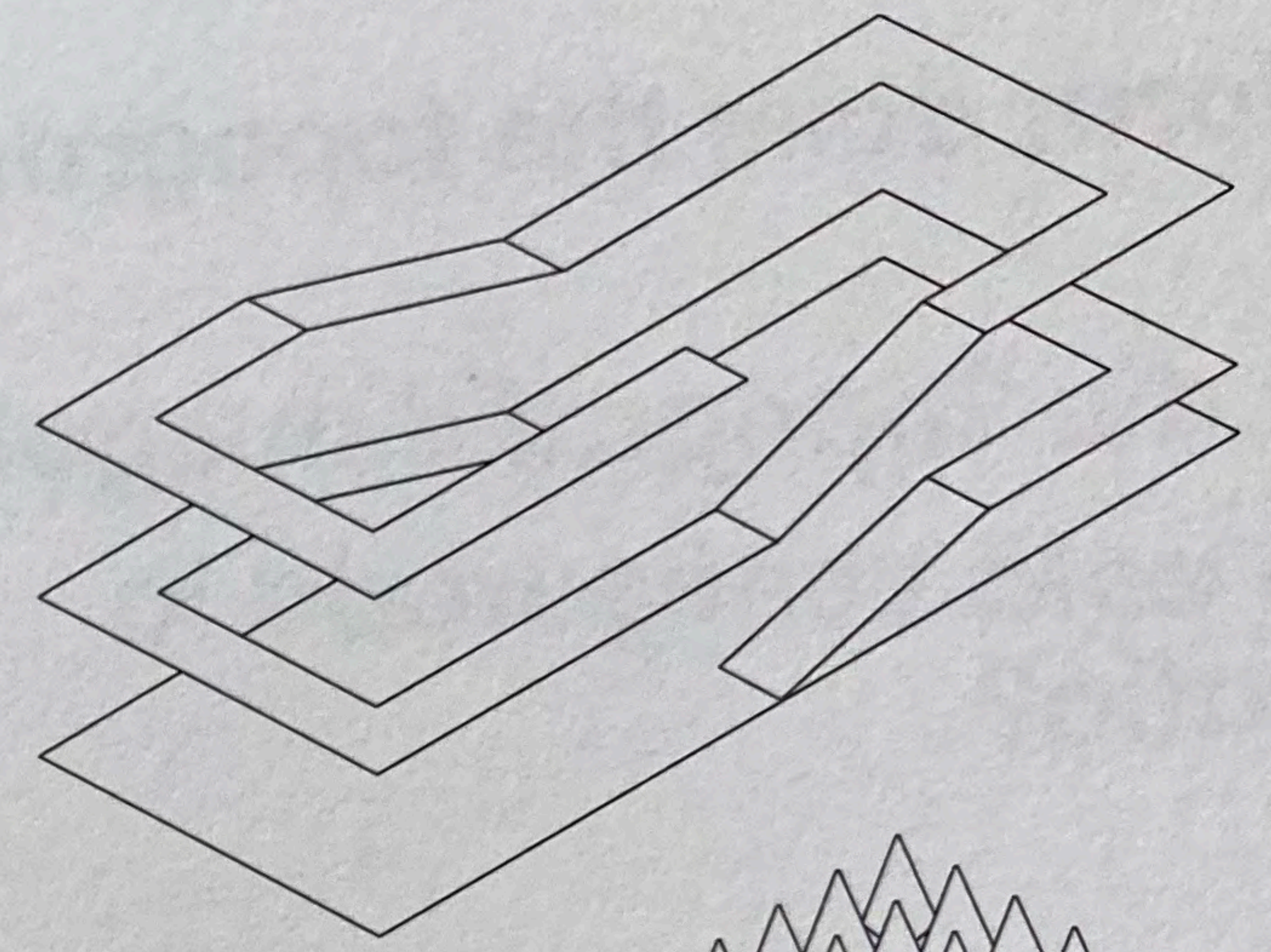

3.1

How can strategic measures in the landscape improve the urban climate?

Wie können strategische Maßnahmen in der Landschaft das Stadtklima verbessern?

¿Cómo pueden mejorar el clima urbano las medidas estratégicas del paisajismo?

- Ideas for London, John Claudius Loudon, 1829
- Der Wald- und Wiesengürtel, Hermann Jansen, 1910
- Freifächensystem nach Einflußzonen, Martin Wagner, 1915
- Parc du Sausset, Atelier Corajoud, 1981
- National Outline Plan for Afforestation, Shlomo Aronson, 1986
- **05** Barnimer Feldmark, Atelier LOIDL, Plancontext, Schirmer und Kernbach, 2001
- Orongo Station, Nelson Byrd Woltz, 2002
- Landschaftspark Riem, Latitude Nord, 2005
- Milano Green Rays, LAND, 2005–
- Metrobosco, Stefano Boeri Architetti, 2007
- Fresh Kills Lifescape, James Corner Field Operations, 2007–
- Pulheimer Nordpark, bbz landschaftsarchitekten, 2008
- Bayou Greenways, SWA Group, 2012
- Anglet South Coastline, Debarre Duplantier Associés Architecture & Paysage, 2013
- Marina One, Gustafson Porter + Bowman + Christoph Ingenhoven, 2017

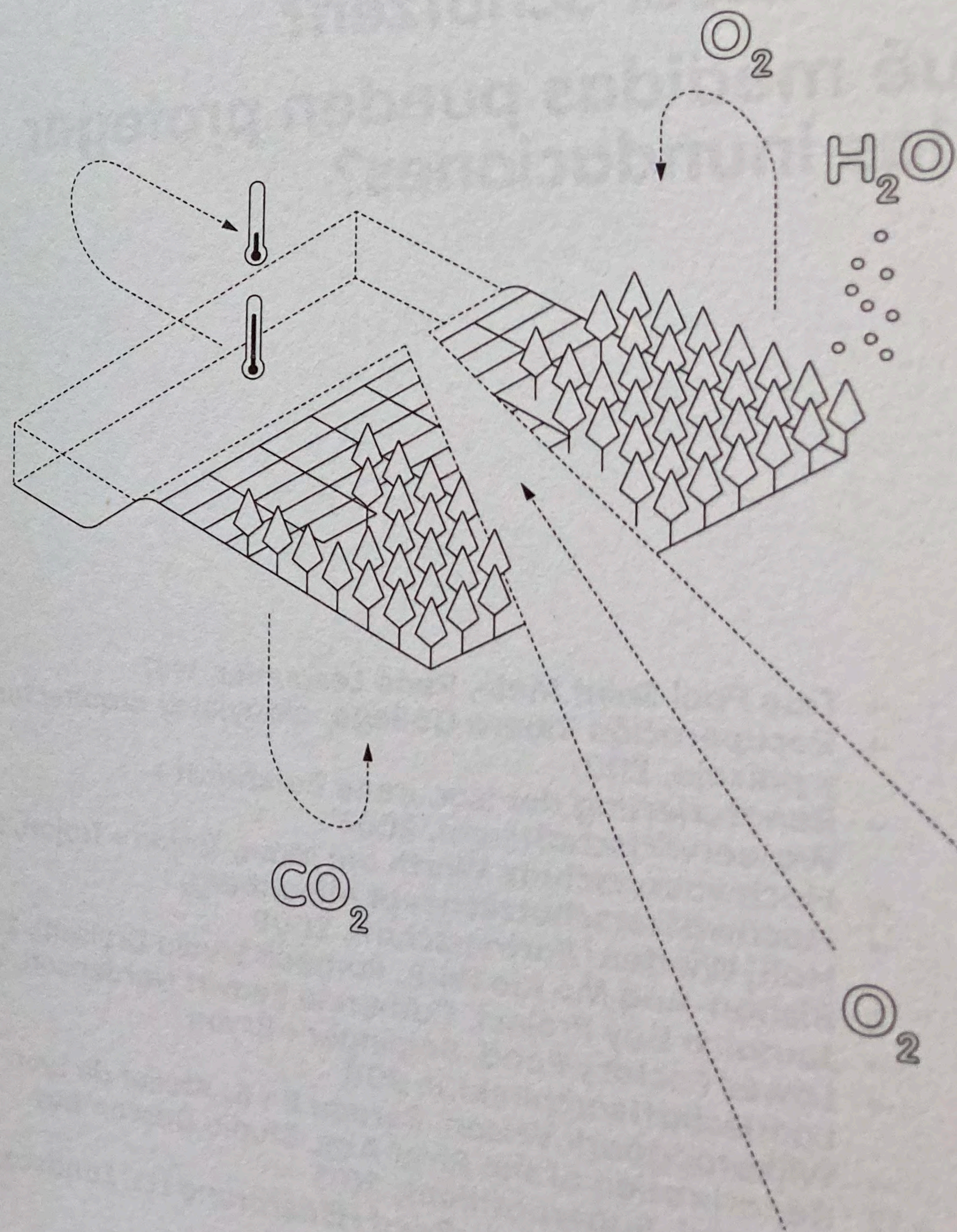

2.8

How can one mitigate negative interactions between the park and its surroundings?

Wie kann mit negativen Effekten zwischen Park und Umgebung umgegangen werden?

¿Cómo pueden reducirse los impactos negativos entre el parque y su entorno?

- Naerum Allotment Gardens, Carl Theodor Sørensen, 1952
- 02 Jim Ellis Freeway Park, Lawrence Halprin + Angela Danadjieva, 1967
- Parc de la Trinitat, Batlle i Roig, 1993
- Crosswinds Marsh Wetland, SmithGroup, 1995
- Parc Corbière, HYL, 1996
- Familistère Garden, BASE Landscape Architecture, 2002
- Olympic Sculpture Park, Weiss Manfredi, 2007
- KM ROSSO Science and Technology Park, Atelier Jean Nouvel + LAND, 2008
- Rudolf Bednar Park, Hager Partner, 2008
- 11 Miyashita Park, Atelier Bow-Wow, 2010
- Alcântara Wastewater Treatment Plant, PROAP, 2011
- Toronto Underpass Park, PFS Studio and The Planning Partnership, 2012
- Bundesgartenschau Heilbronn, sinai, 2019

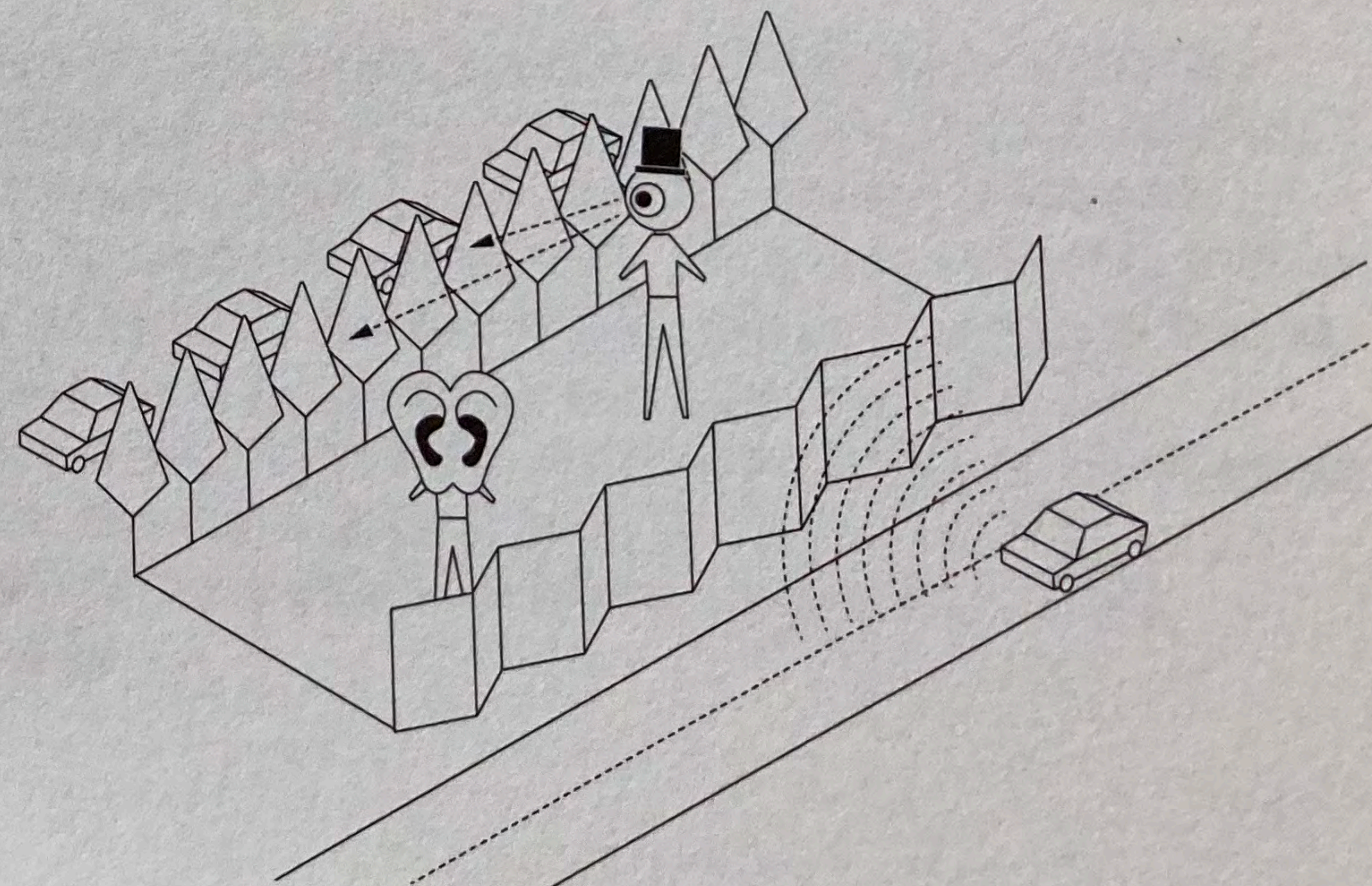
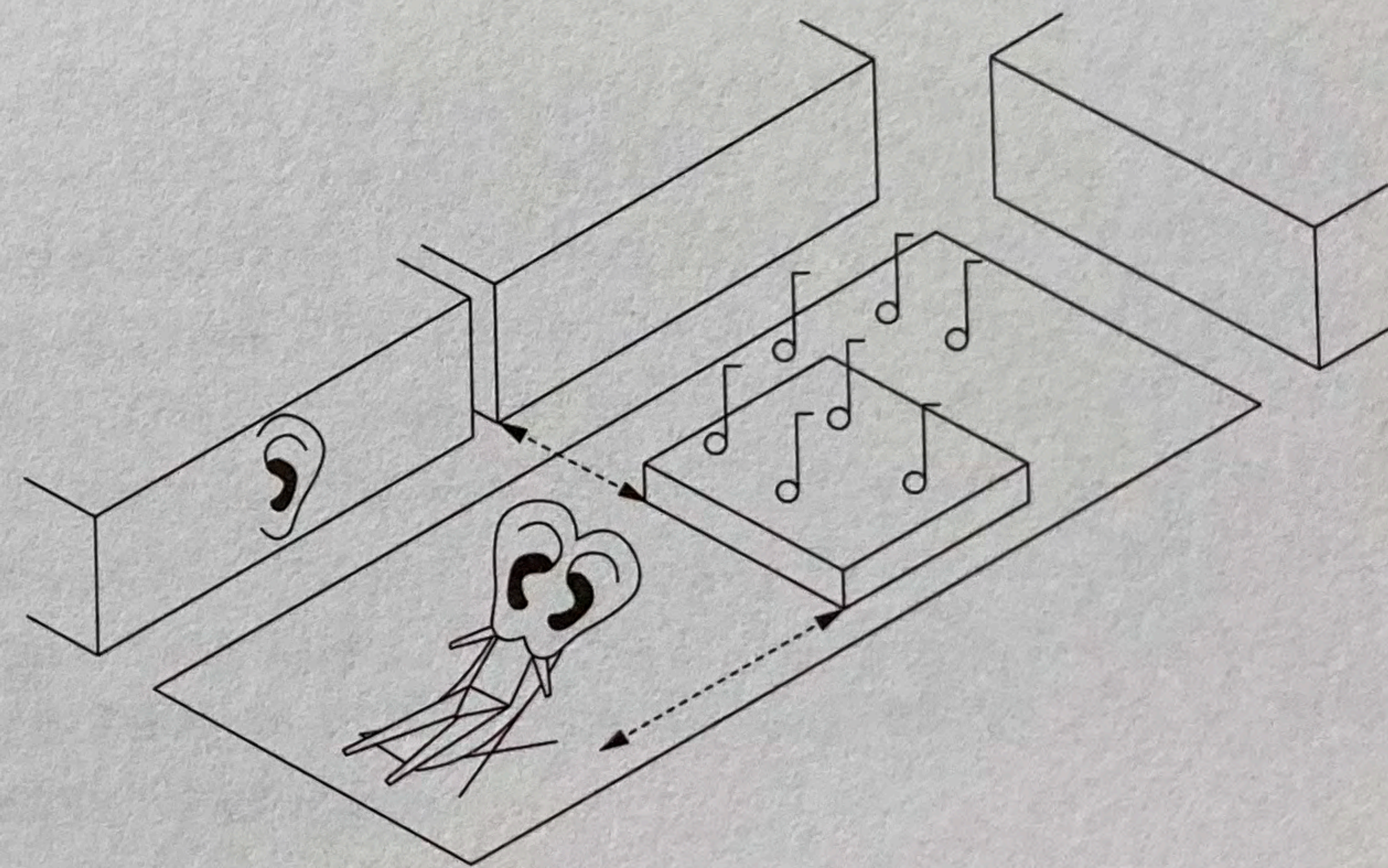
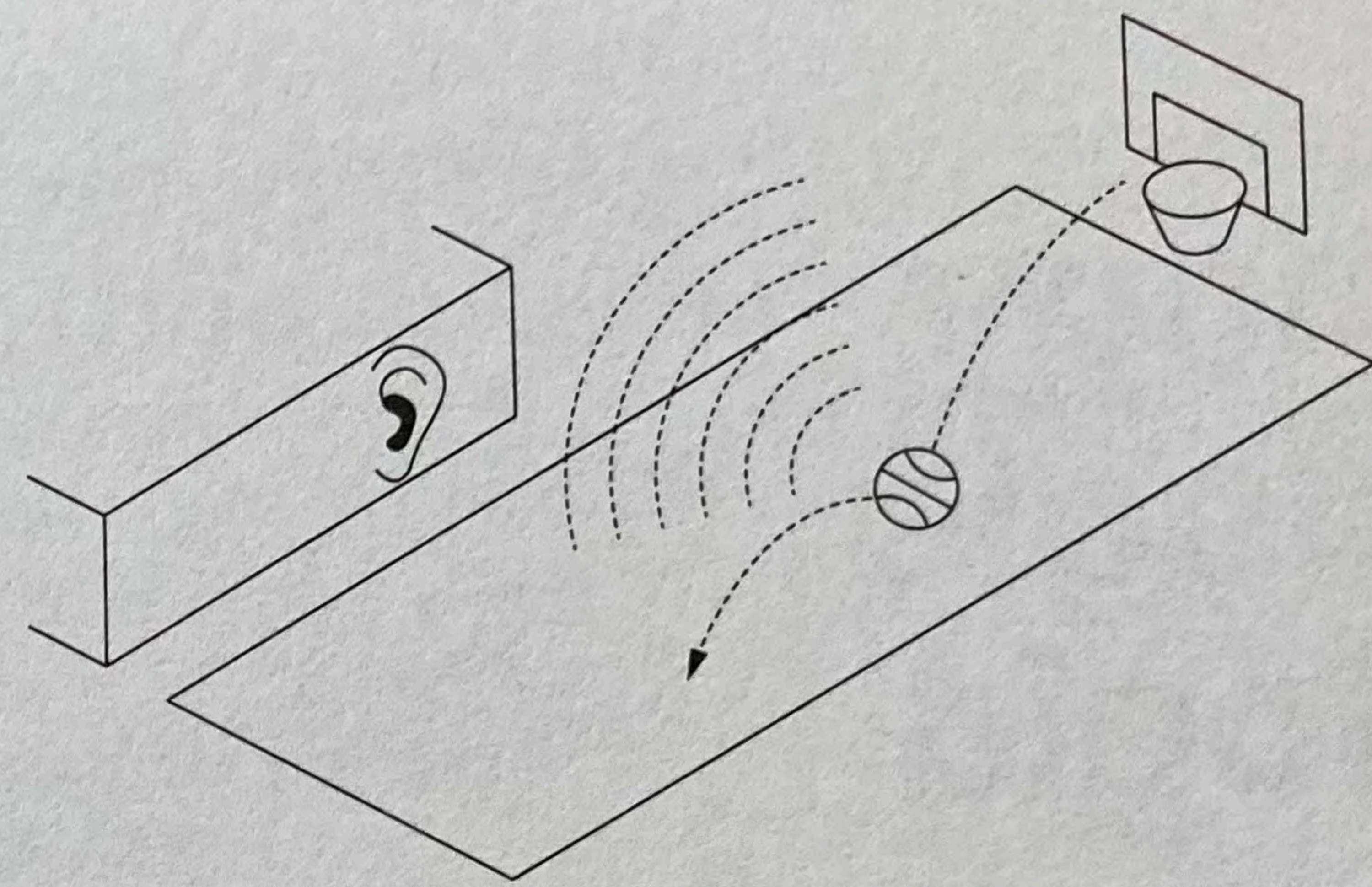

4.4

How can one encourage informal uses and appropriation processes?
Wie können informelle Nutzungen und Aneignungsprozesse erleichtert werden?

¿Cómo pueden facilitarse los usos informales y los procesos de apropiación?

- Plaça de la Constitució, José Antonio Martínez Lapeña & Elías Torres Arquitectos, 1993
- Tate Gallery of Modern Art, Herzog & de Meuron + Kienast Vogt Partner, 2000
- Festivalzentrum Theaterformen, Kuehn Malvezzi, 2002
- Torre de David Caracas, 2007
- Schulanlage Obstgarten Stäfa, vetschpartner Landschaftsarchitekten, 2007
- Botteskerkpark, Karres en Brands, 2009
- Parkpioniere Tempelhof, Ideenwerkstadt Tempelhof (mbup, raumlaborberlin, Studio UC), Stadt Berlin, 2011
- Kopfkino, ON/OFF, 2012
- Superbob, Umschichten, 2012
- ESCARAVOX, Andrés Jaque / Office for Political Innovation, 2017
- Borderwall as Architecture, Ronald Rael, 2019



1.5

How do weather and climate influence the use of the open space?

Wie beeinflussen Wetter und Klima die Freiraumnutzung?

¿Cómo influye el clima y el tiempo atmosférico en los usos al aire libre?

- Aqua Alta Gangways Venice, 1100–
- Piscinas de Marés, Álvaro Siza Vieira, 1966
- Sun Tunnels, Nancy Holt, 1976
- Wind Veil – Gateway Village, Ned Kahn, 2000
- Ankarparken, SLA, 2001
- Parc de Diagonal Mar, Miralles Tagliabue EMBT, 2002
- The Weather Project, Studio Olafur Eliasson, 2003
- Hotel Park Hyatt Wettergarten, Vogt Landschaftsarchitekten, 2004
- Mezyad Desert Park, Gustafson Porter + Bowman, 2007
- I Need Some Meaning I Can Memorise (The Invisible Pull), Ryan Gander, 2012
- Rjukan sun, Martin Andersen + Sam Eyde, 2014
- Vieux-Port Marseille, MDP Michel Desvigne Paysagiste + Foster + Partners, 2016
- Amager Bakke, BIG + SLA, 2017
- Ice Watch, Studio Olafur Eliasson, 2017
- Fog x Ruins in Franklin Park, Fujiko Nakaya, 2018



2.4

How does the park respond
to the existing topography?
Wie reagiert der Park auf die
vorhandene Topografie?

¿Cómo reacciona el parque
a la topografía existente?

- Garden of Villa d'Este, Pirro Ligorio, Alberto Galvani, 1560
- Giardino di Boboli, Niccolò Tribolo, Bartolomeo Ammanati, Giorgio Vasari + Bernardo Buontalenti, 16th century
- Parc Güell, Antoni Gaudí, 1914
- Parc de Montjuïc, Jean Claude Nicolas Forestier, Nicolau Maria Rubió i Tudurí, 1929
- 01 Volkspark Rehberge, Erwin Barth + Rudolf Germer, 1929
- Skogskyrkogården, Gunnar Asplund + Sigurd Lewerentz, 1940
- Olympiapark, Günther Grzimek + Behnisch & Partner, Frei Otto, 1972
- Parc de la Creueta del Coll, MBM + Eduardo Chillida, 1987
- Parc del Mirador del Migdia, Beth Galí, Jaume Benavent, Andreu Arriola, 1992
- Jardin de l'Imaginaire, Gustafson Porter + Bowman, 1996
- 05 Jardí Botànic, Bet Figueras + Carlos Ferrater, 1999
- Rotten Row Gardens, GROSS.MAX., 2003
- Tilla-Durieux-Park, DS landschapsarchitecten, 2003
- Parque Bicentenario de la Infancia, Elemental, 2012
- Minghu Wetland Park, Turenscape, 2012
- Jardín Niel, Michèle & Miquel Architectes & Paisatgistes + Teresa Galí + Alberto Hernández Medina, 2018

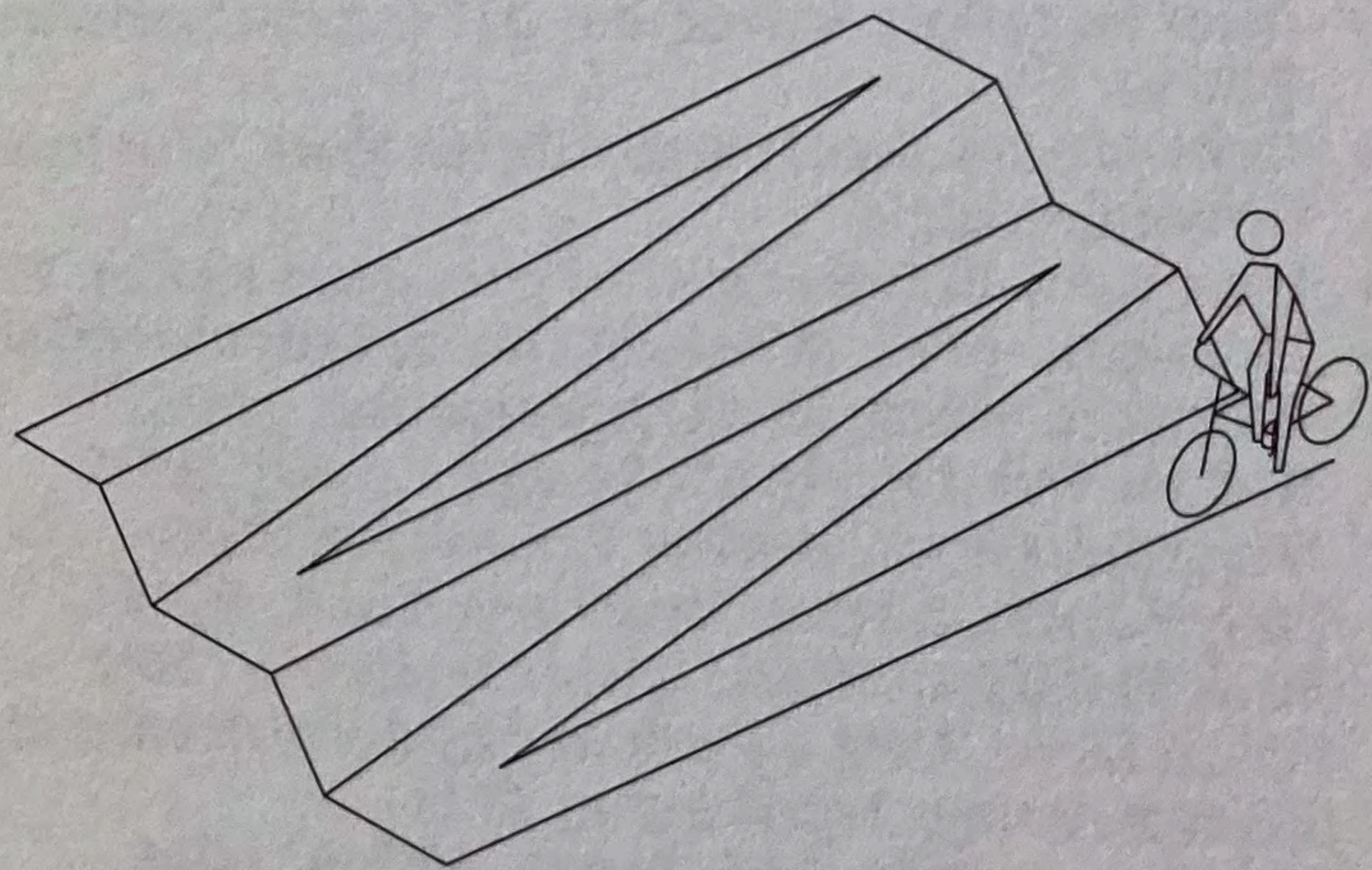
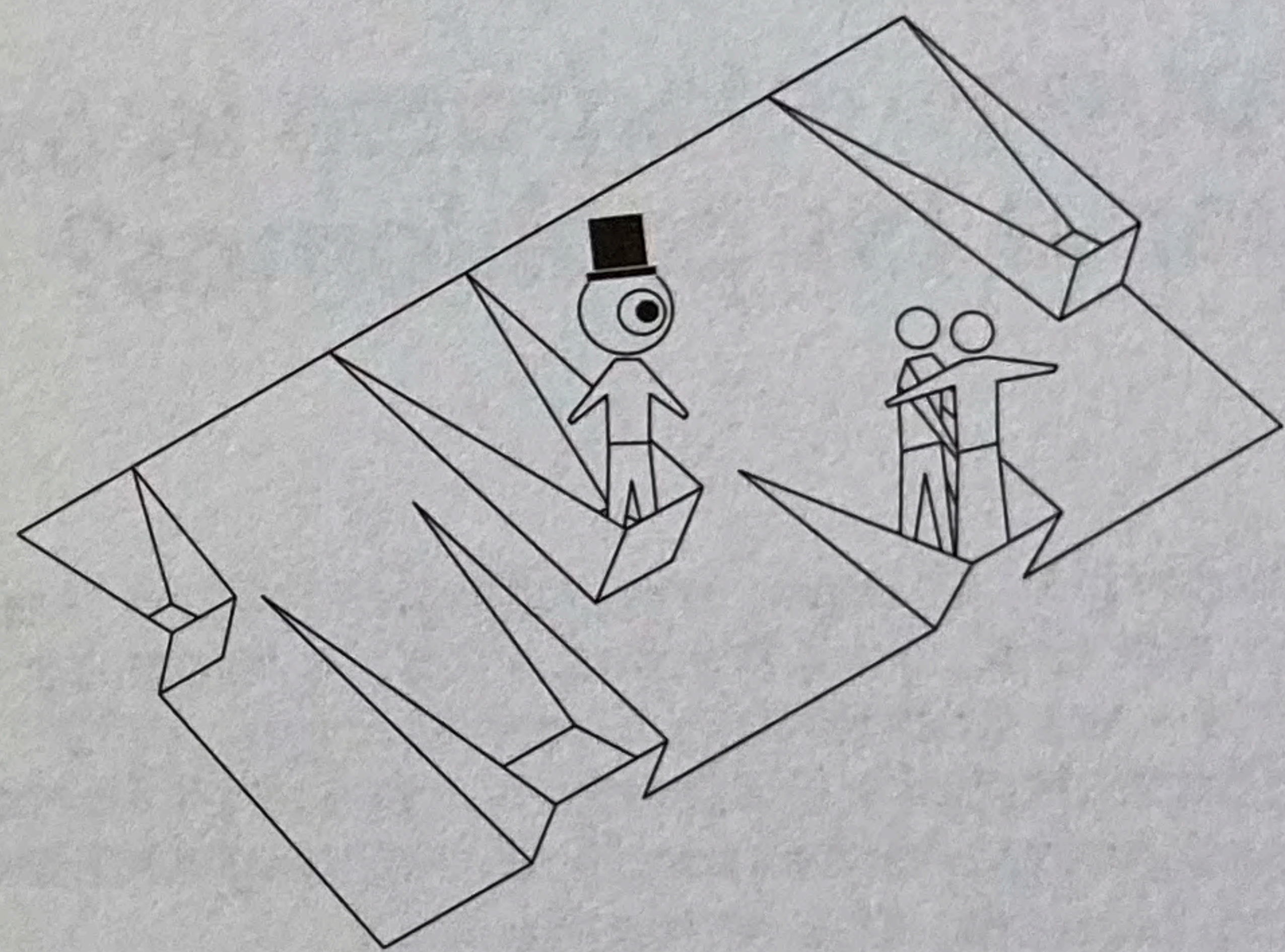
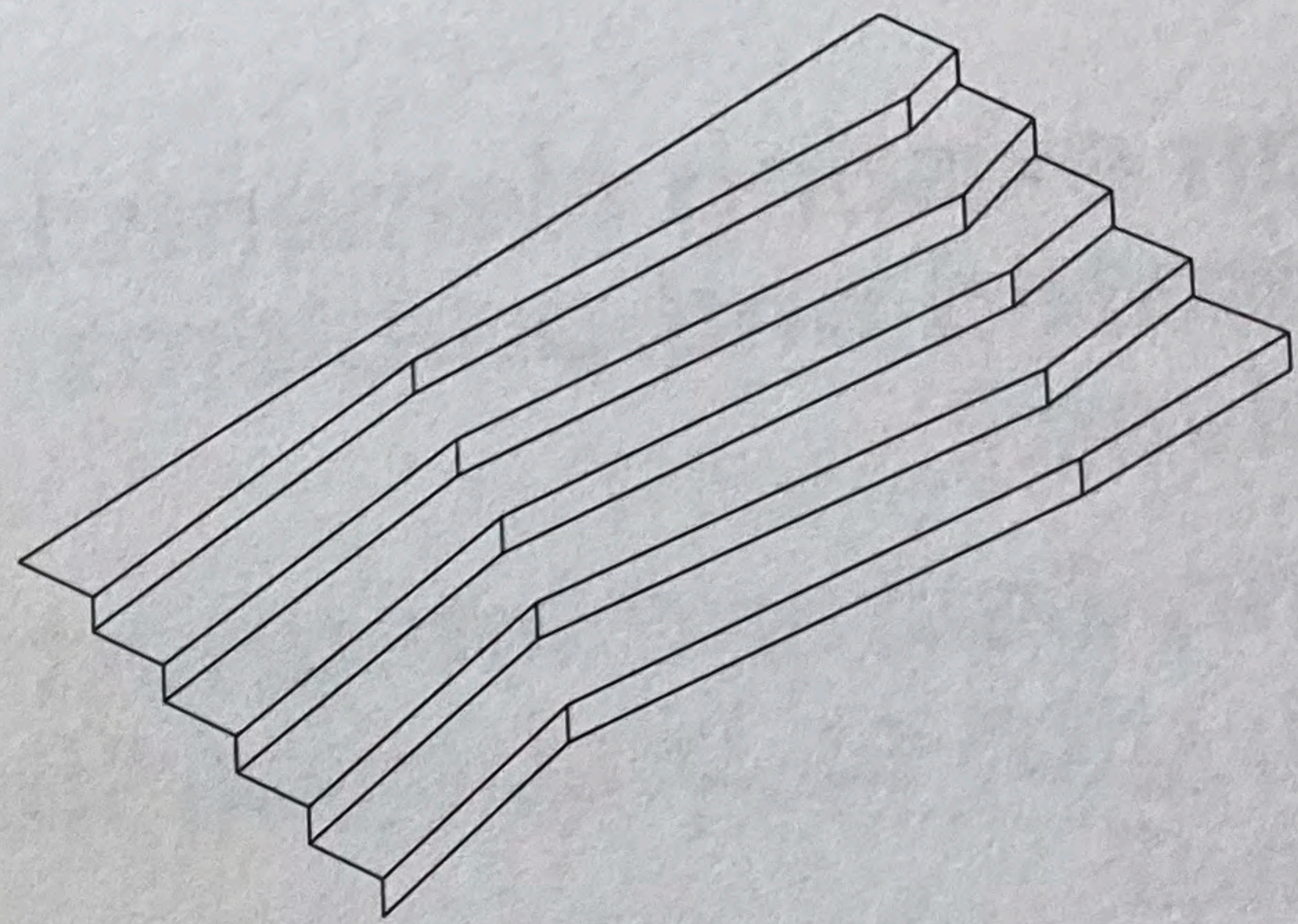

4.7

What kinds of food production can be incorporated into a park?

Welche Angebote zur Nahrungsproduktion können integriert werden?

¿Qué ofertas de producción alimentaria pueden integrarse?

- Chateau et Jardins de Villandry, Jean Le Breton, 1532; Dr. Joachim Carvallo, 1918
- Parc de Chantilly, André Le Nôtre, 1673
- Potager du Roi, Jean-Baptiste de La Quintinie, 1683
- 01 Volkspark Rehberge, Erwin Barth + Rudolf Germer, 1929
- Amsterdamse Bos, Cornelis van Eesteren + Jakoba Mulder, 1930
- Naerum Allotment Gardens, Carl Theodor Sørensen, 1952
- Parc du Sausset, Atelier Corajoud, 1981
- Parc François Mitterrand, Desvigne & Dalnoky, 1994
- Parc de Bercy, Bernard Huet, Madeleine Ferrand, Jean-Pierre Feugas, Bernard Leroy + Ian Le Caisne, Philippe Raguin, 1997
- Neue Wiesen, Schirmer + Kernbach, 1998
- Parc Agricole, Kamel Louafi, 2000
- Parc de Pedra Tosca, RCR Arquitectes, 2004
- Parc des Cormailles, Agence Ter, 2006
- Parque Sa Riera, Ravetllat Ribas, 2007
- Victor Civita Park, Benedito Abbud, 2008
- Normand Park, KLA, 2008
- South Lake Central Park, Landscape Architecture at Beijing Tsinghua, 2008
- Prinzessinnengärten, Nomadisch Grün, 2009

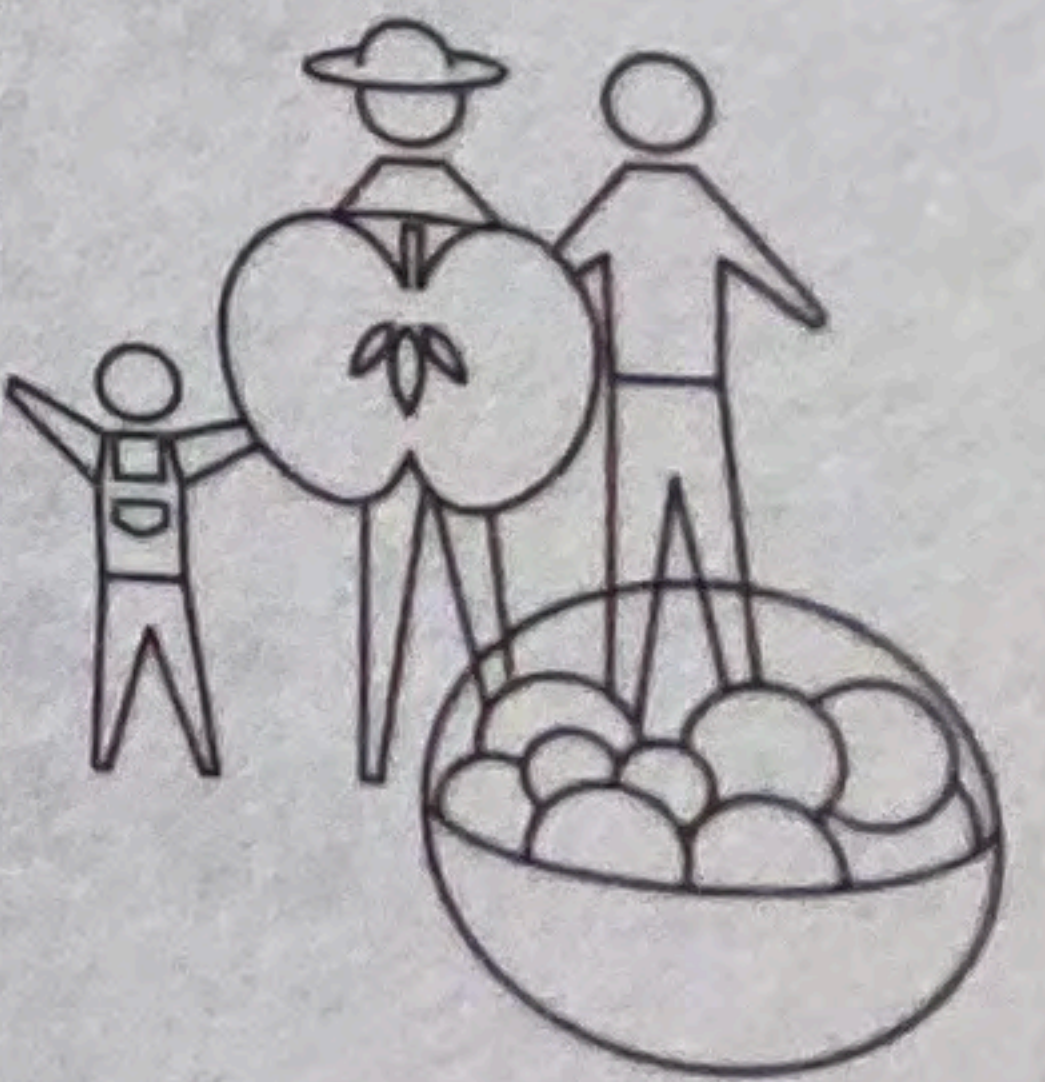
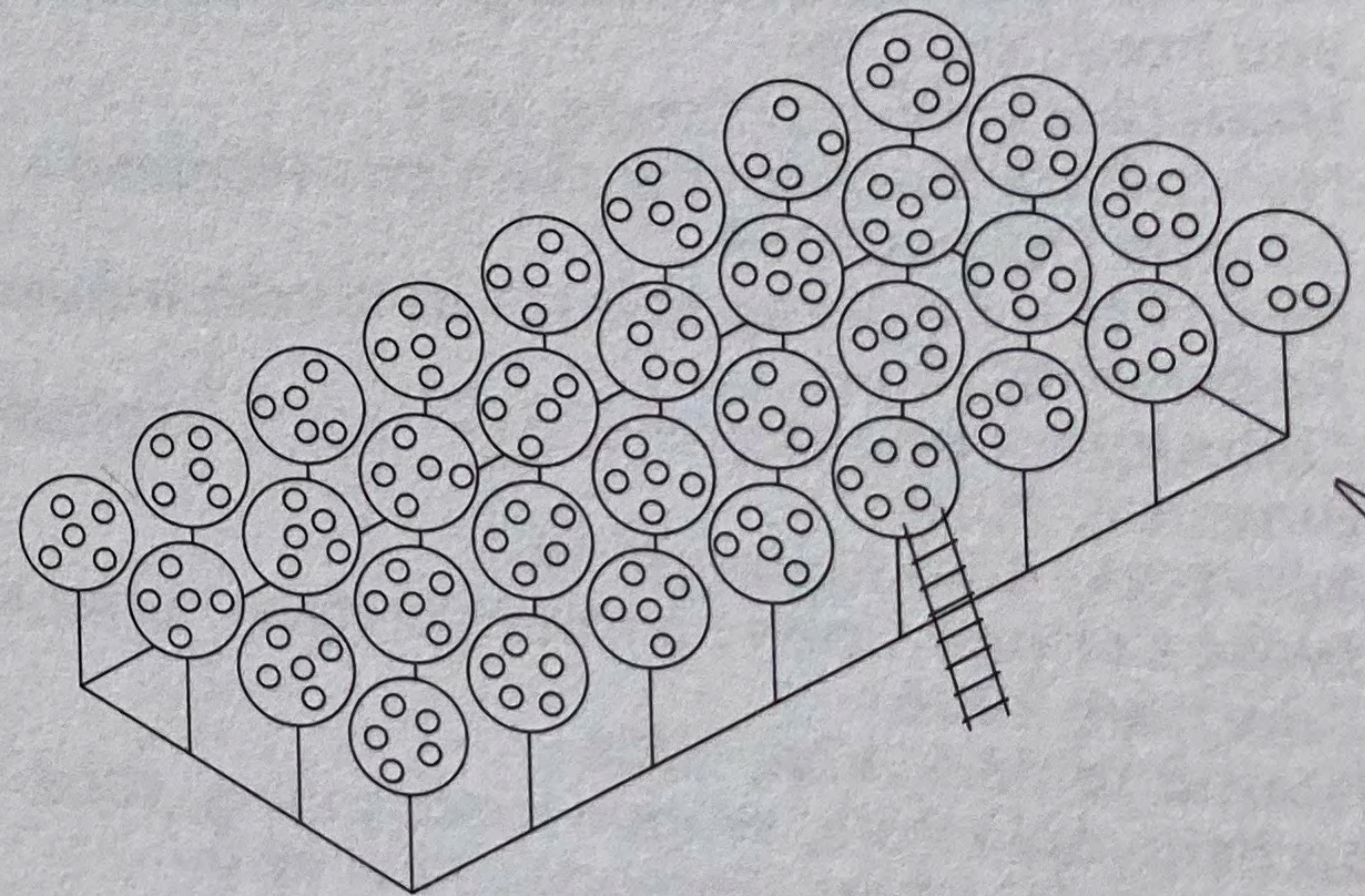
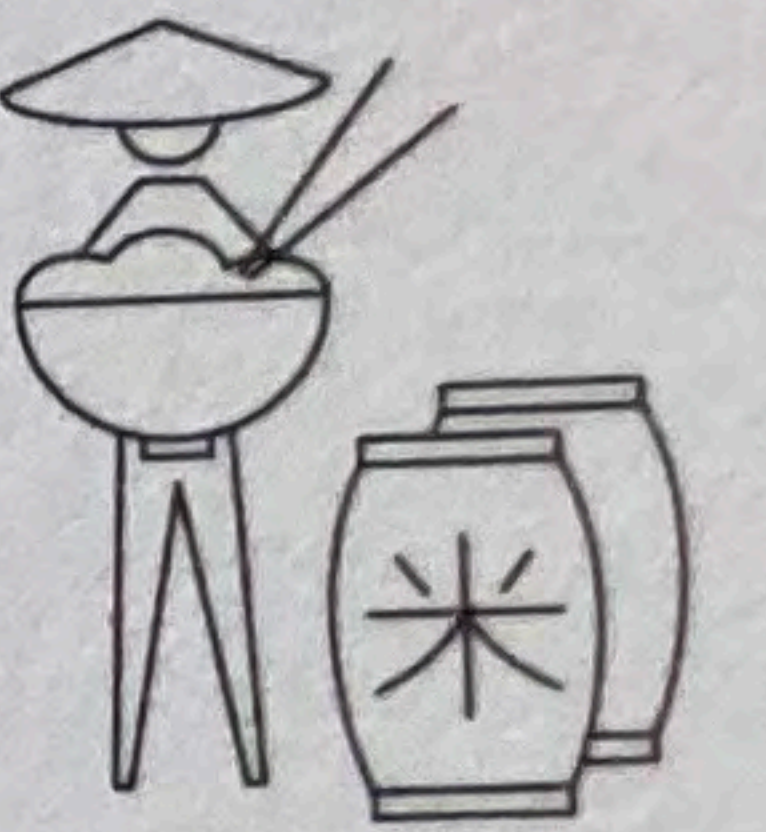
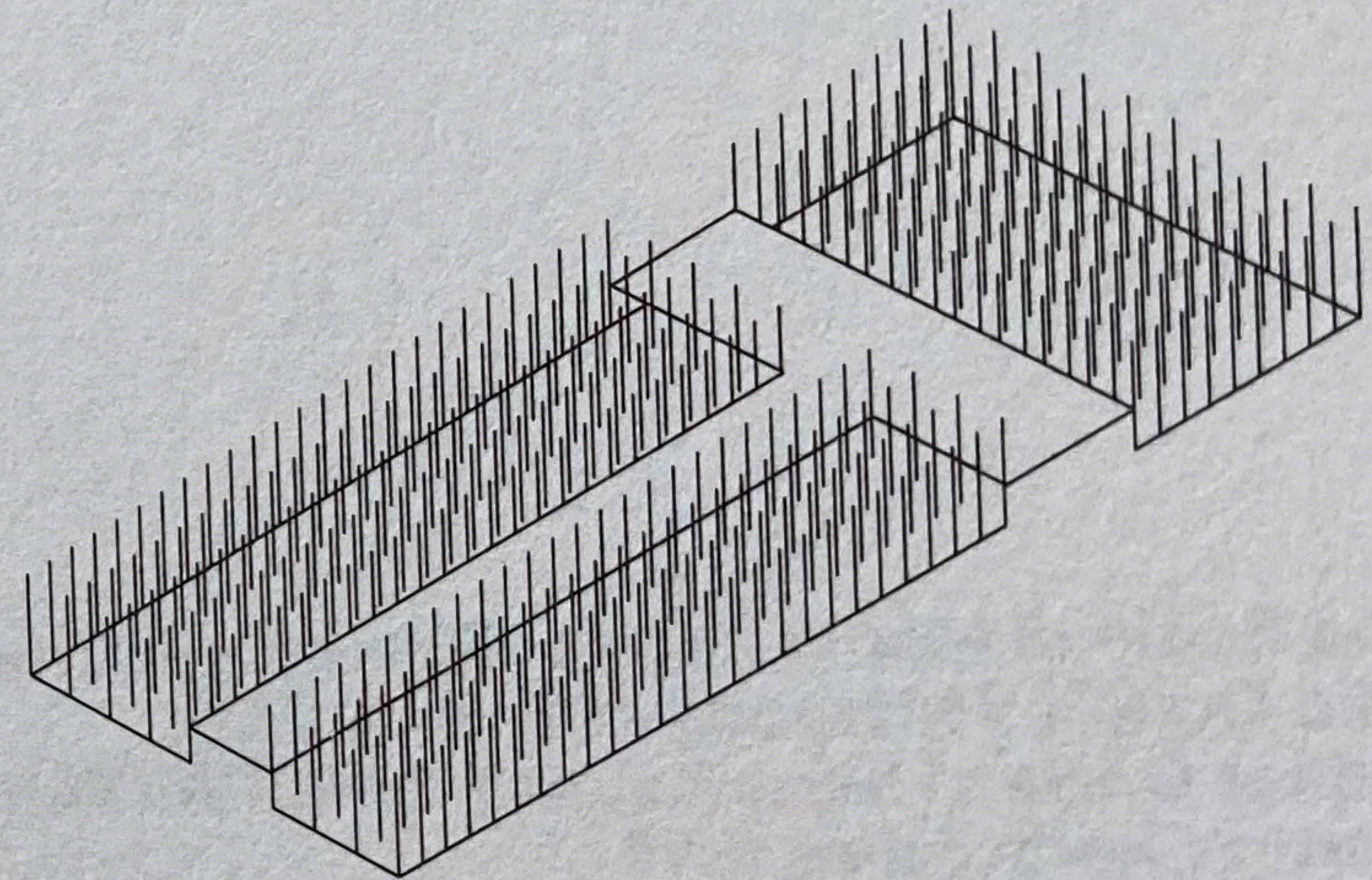
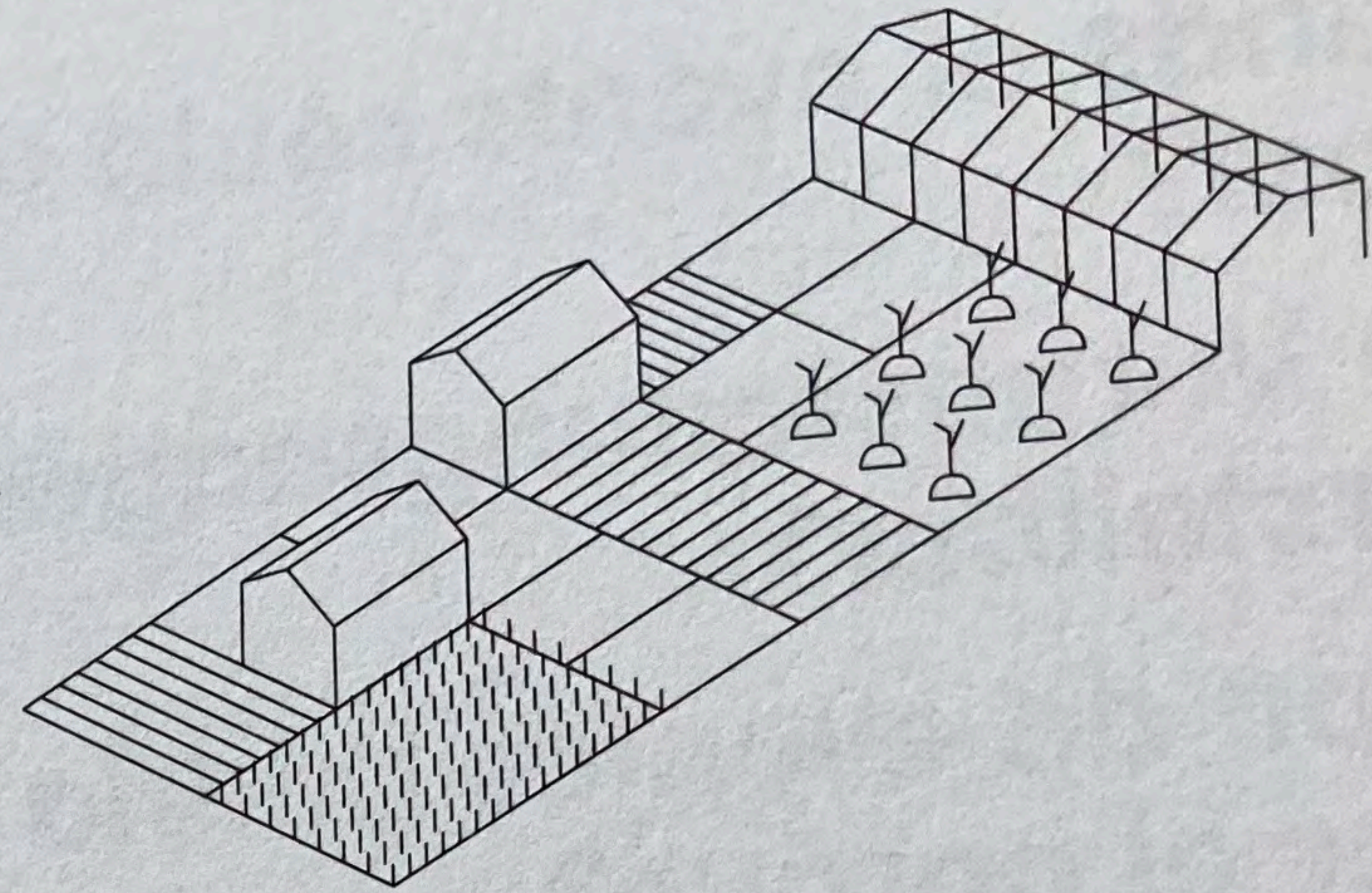

7.4

What form does the topography have?

Wie ist die Topografie ausgeformt?

¿Cómo está configurada la topografía?

- Parc de Montjuïc, Jean Claude Nicolas Forestier, Nicolau Maria Rubió i Tudurí, 1929
- Garten des Poeten, Ernst Cramer, 1957
- Olympiapark, Günther Grzimek + Behnisch & Partner, Frei Otto, 1972
- Parc de la Creueta del Coll, MBM + Eduardo Chillida, 1987
- Parc de la Trinitat, Batlle i Roig, 1993
- Parc Corbière, HYL, 1996
- Jardin de l'Imaginaire, Gustafson Porter + Bowman, 1996
- Folded Land, Maya Lin, 2003
- Barry Curtis Park, Isthmus, 2004
- 08 Swiss Cottage Open Space, Gustafson Porter + Bowman, 2006
- Teardrop Park, MVVA, 2006
- Müngstener Brückenpark, Atelier LOIDL, 2006
- South Lake Central Park, Landscape Architecture at Beijing Tsinghua, 2008
- Ariel Sharon Park & Hiriya Landfill Rehabilitation, Latz + Partner Landschaftsarchitektur Stadtplanung Architektur, 2004–
- Ballast Point Park, McGregor Coxall, 2009
- Rheinpark, Atelier LOIDL, 2010
- Parque Bicentenario de la Infancia, Elemental, 2012
- Minghu Wetland Park, Turenscape, 2012
- Lewis Cubitt Park, Townshand Landscape Architects, 2015
- Sommerinsel Bundesgartenschau Heilbronn, LOMA architecture.landscape.urbanism, 2019

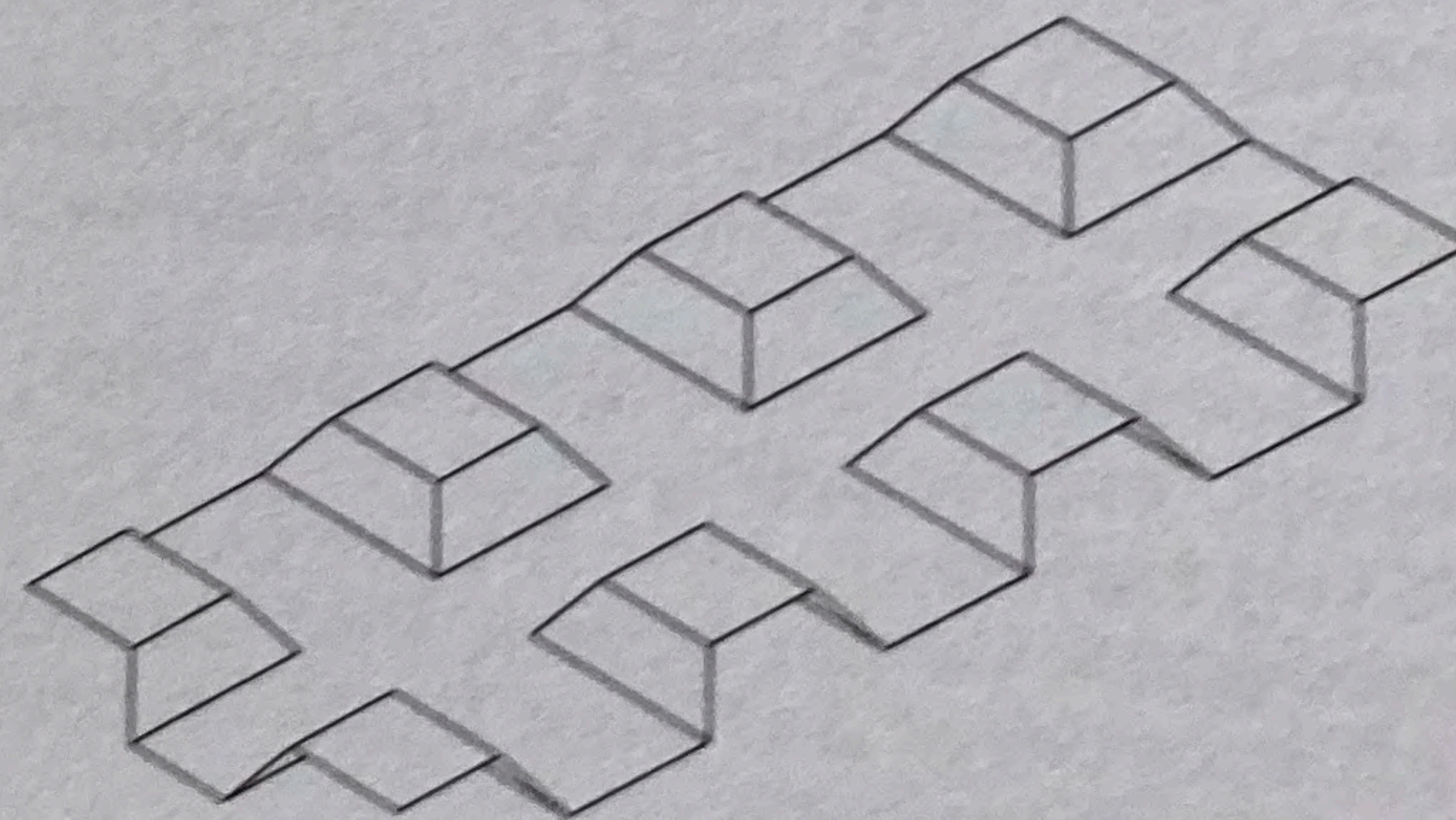
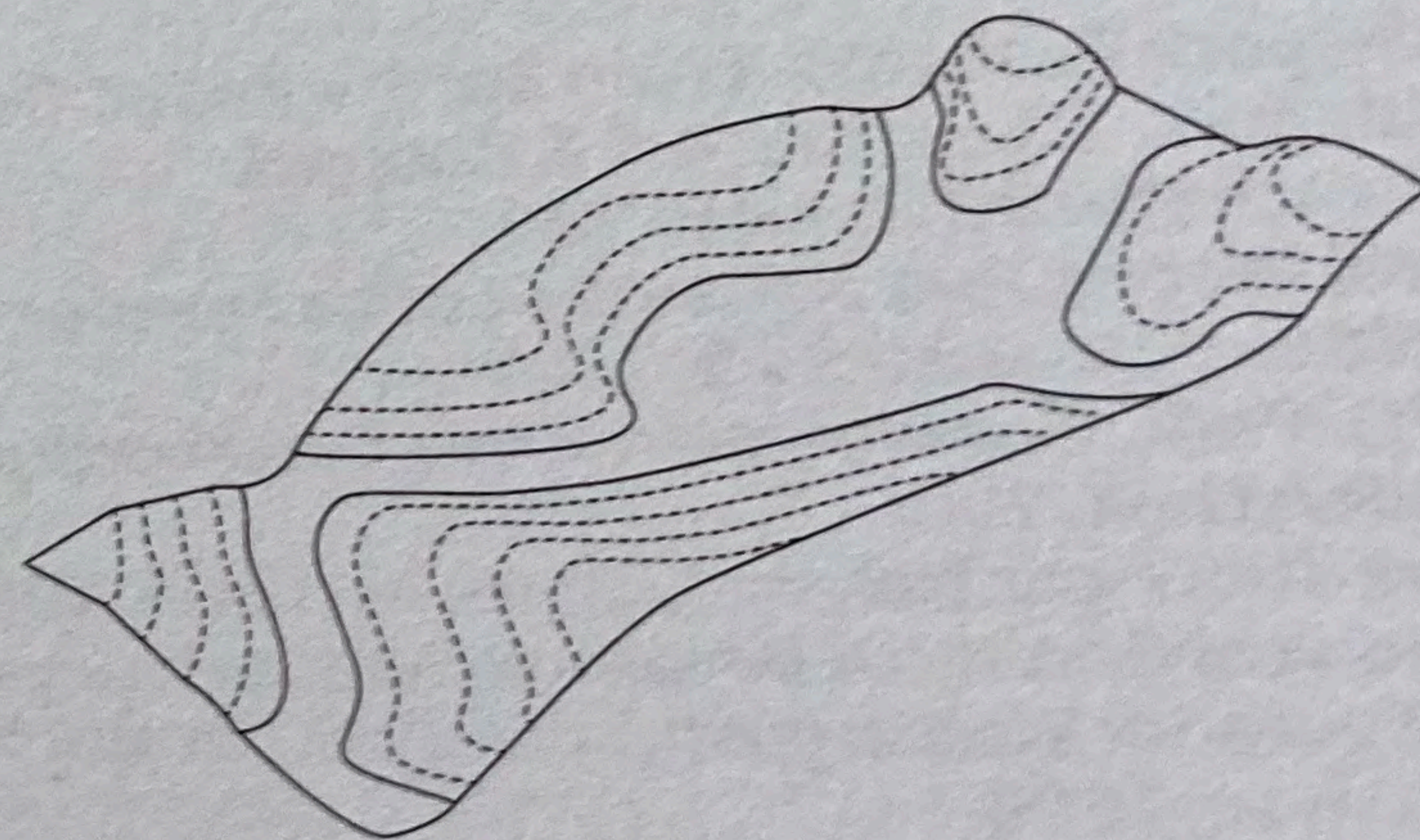
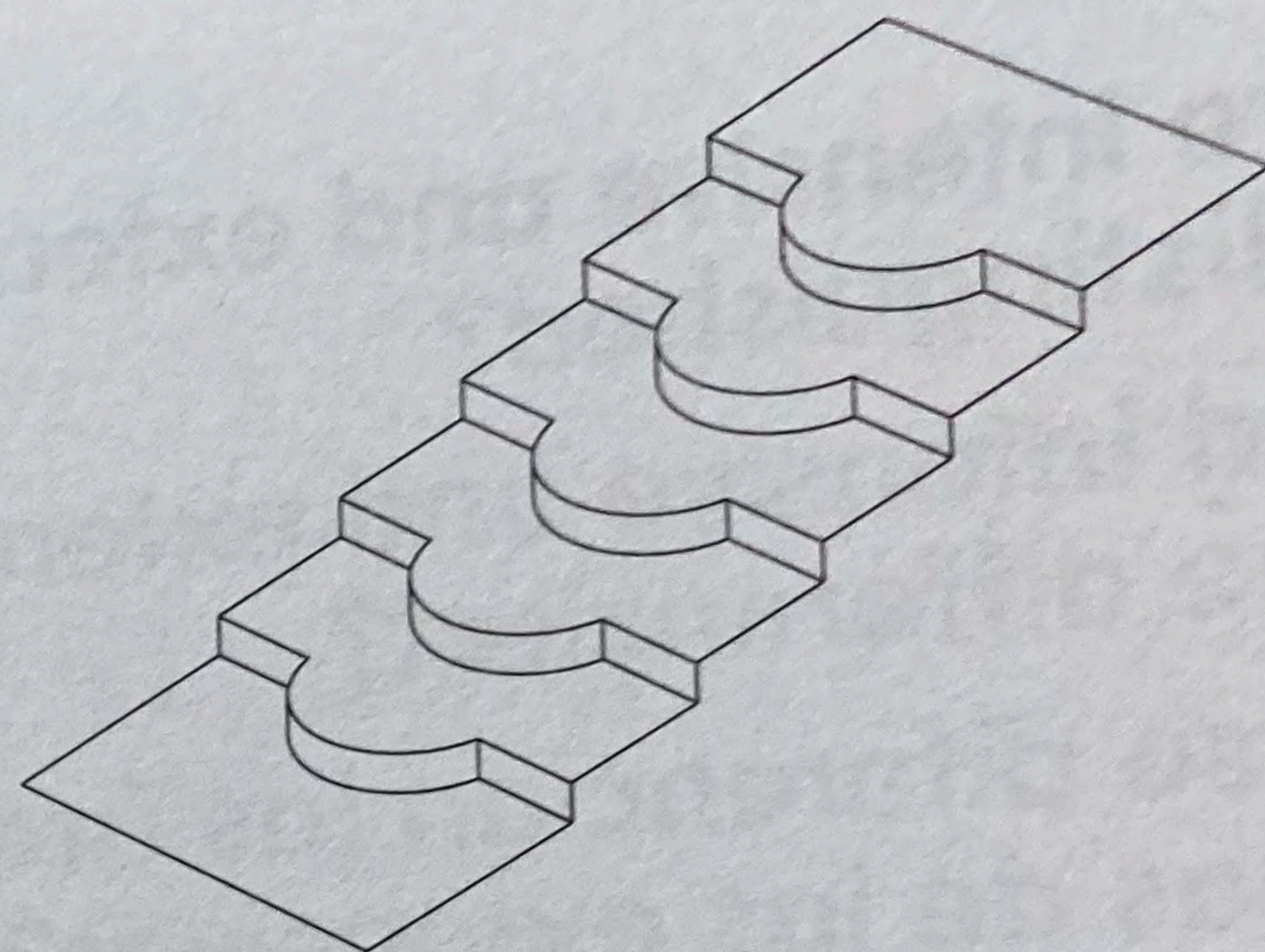

1.10

Is it part of a system of parks?
Ist er Teil eines Parksystems?
¿Forma el parque parte de un sistema?

- Nürnberger Waldplan, Erhard Etzlaub, 1516
- Wiener Glacis, 1529–1858; »Regulierung« unter Joseph II., 1770–
- Boston Emerald Necklace, Frederick Law Olmsted, 1860
- Plan of Chicago, D. H. Burnham, E. H. Bennett, 1909
- Der Wald- und Wiesengürtel, Hermann Jansen, 1910
- Grüngürtel Köln, Fritz Schumacher, 1922
- Halprin Open Space Sequence, Lawrence Halprin, 1966
- Coulée Verte René-Dumont, Philippe Mantoux, Jacques Vergely + Patrick Berger, 1994
- Mauerpark, Gustav Lange, 1995
- Dania Park, Thorbjörn Andersson, 1999
- Ankarparken, SLA, 2001
- Parc de la Feysine, Ilex paysage + urbanisme, 2001
- 06 MFO-Park, Planergemeinschaft Burckhardtpartner / Raderschall, 2001
- Oerliker Park, Zulauf Seippel Schweingruber + Haerle Hubacher Architekten, 2001
- Wahlenpark, Dipol Landschaftsarchitekten, 2005
- Milano Green Rays, LAND, 2005–
- Tilla-Durieux-Park, DS landschapsarchitecten, 2003
- Park of Luna, HOSPER + DRFTWD, 2008
- Park am Nordbahnhof, Fugmann & Janotta, 2009
- Parc de la Marina, Batlle i Roig, 2009
- Parque Madrid Río, West 8 + Mrio Arquitectos, 2012
- Bayou Greenways, SWA Group, 2012
- 12 Park am Gleisdreieck, Atelier LOIDL, 2014
- The Parklands of Floyd's Fork, WRT, 2016

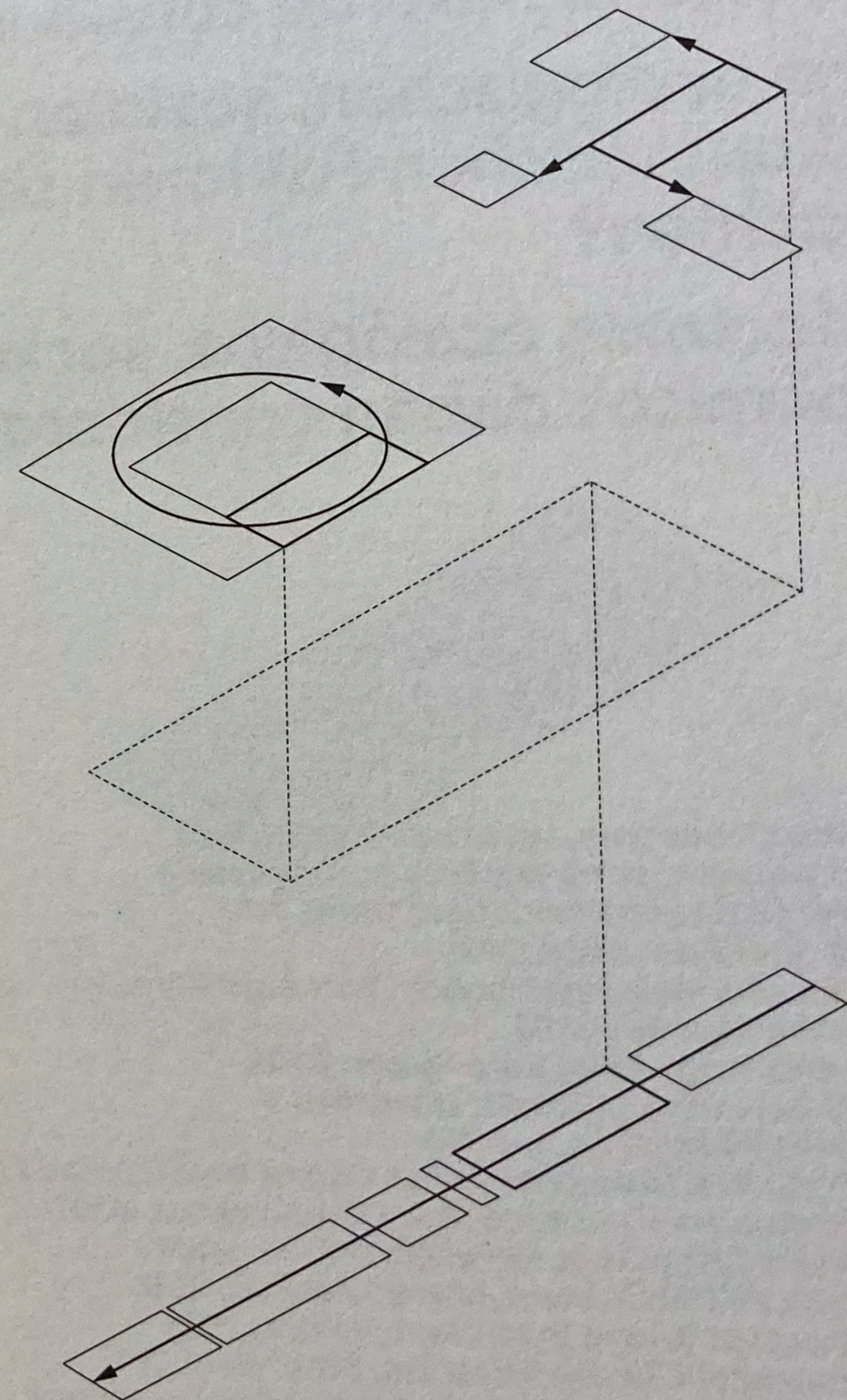

2.1
Who uses open spaces?
Wer nutzt den Freiraum?
¿Quién usa los espacios libres?

- Karneval der Kulturen, Berlin
- Garden of Saihō-ji, Musō Sosek, 731
- Central Park, Frederick Law Olmsted + Calvert Vaux, 1873
- Plaza de los Fueros, Eduardo Chillida, 1980
- Gärten der Welt, Gottfried Funck, 2000
- Allee der Vereinigten Bäume, Kienast Vogt Partner, 2000
- Blindeninstitut Regensburg, Georg Scheel Wetzel
- Architekten + Büro Kiefer, 2006
- Interkultureller Stadtpark, Iohrer.hochrein, 2012
- Superkilen, BIG + Superflex + Topotek 1, 2014
- Gedenk- und Informationsort T4, Heinz W. Hallmann + Ursula Wilms + Nikolaus Koliusis, 2014

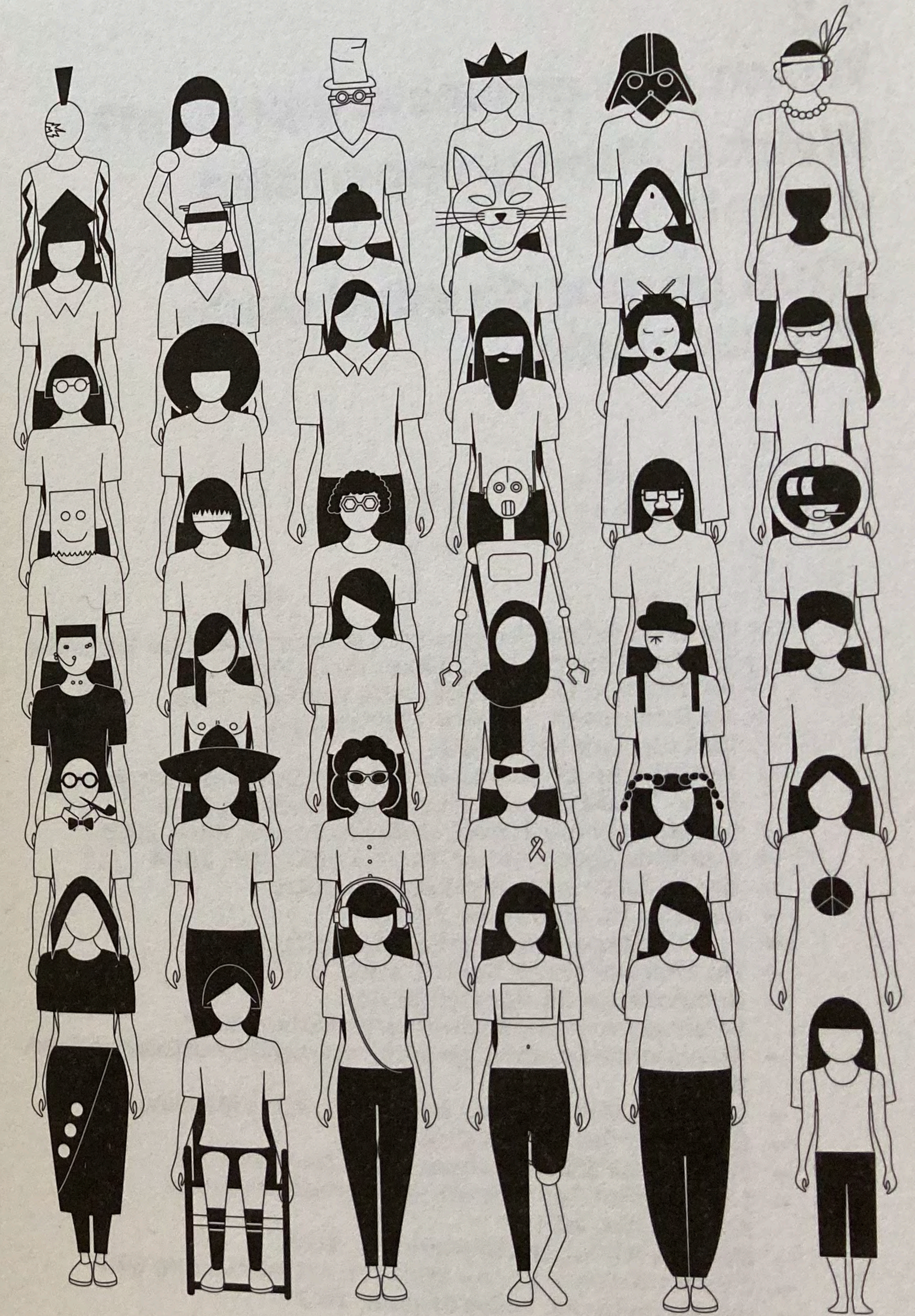

6.6

How can form create identity?

Wie kann Form Identität schaffen?

¿Cómo puede crearse identidad a partir de la forma?

- Flamengo Park, Roberto Burle Marx, 1954
- Burnett Park, PWP Landscape Architecture, 1993
- Interpolis Garden, West 8, 1998
- 05 Jardí Botànic, Bet Figueras + Carlos Ferrater, 1999
- Ankarparken, SLA, 2001
- Landesgartenschau Eberswalde, Topotek 1, 2002
- Vineyard garden, Fernando Caruncho, 2003
- Parc J. B. Lebas, West 8, 2004
- Charlotte Garden, SLA, 2004
- Victor Civita Park, Benedito Abbud, 2008
- The Australian Garden, Taylor Cullity Lethlean + Paul Thompson, 2012
- Sunnylands Center and Garden, James Burnett, 2012
- Parque Madrid Río, West 8 + Mrio Arquitectos, 2012
- Park Killesberg, Rainer Schmidt Landschaftsarchitekten + Stadtplaner, 2013
- Biblioteca degli Alberi, Inside-Outside, Studio Giorgetta + Mirko Zardini, Michael Malzan Architecture + Piet Oudolf et al., 2018
- PIXELAND, 100architects, 2019

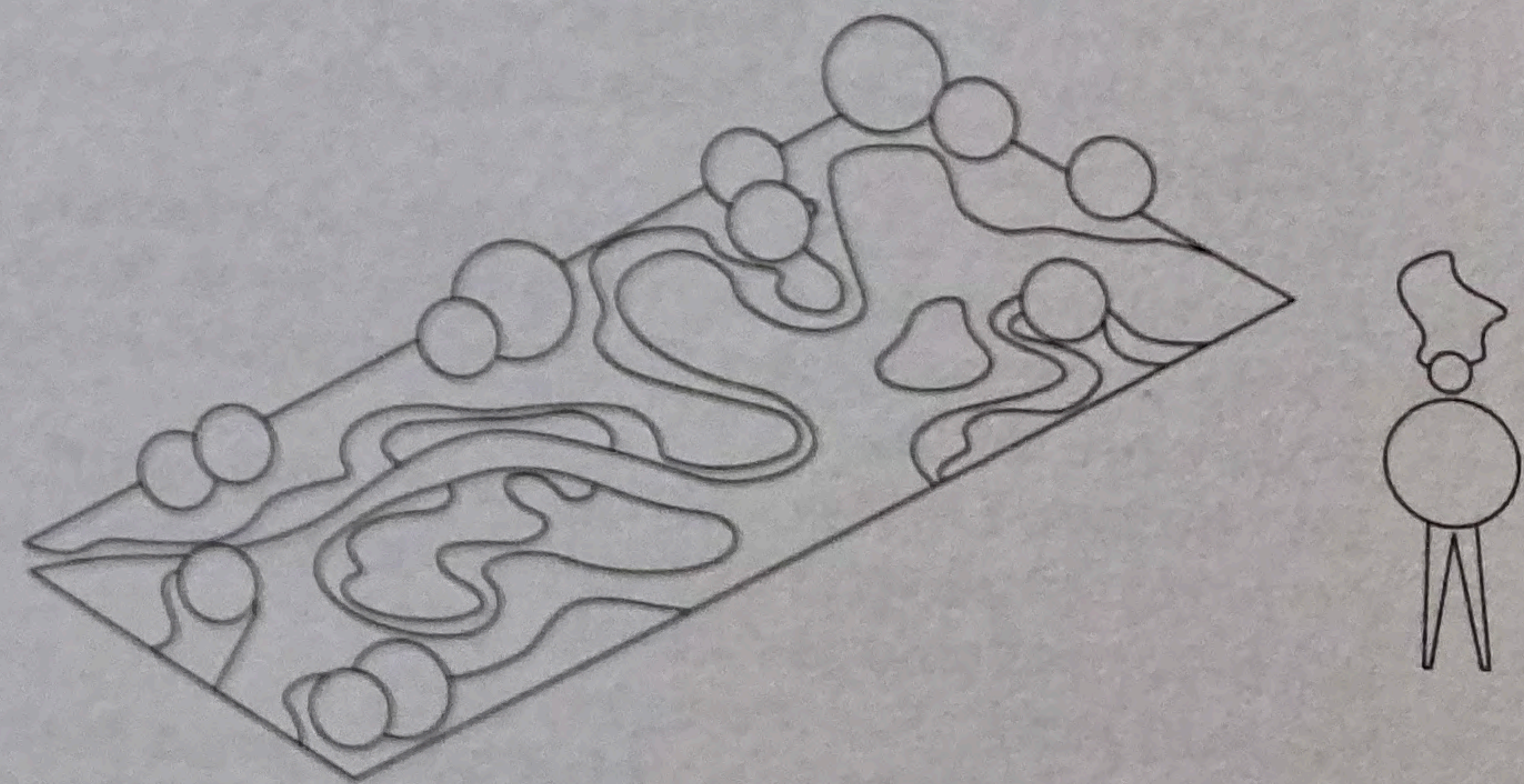
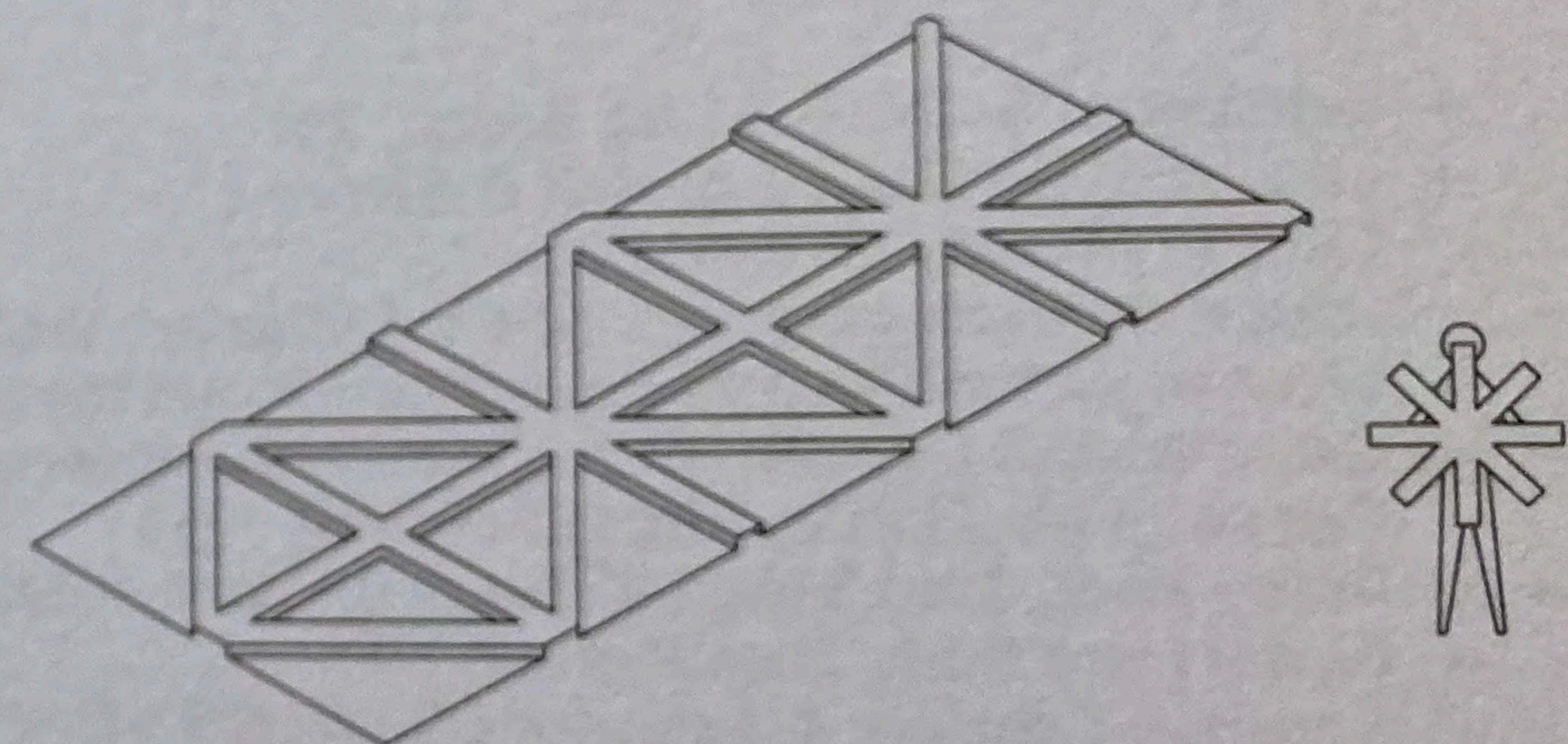
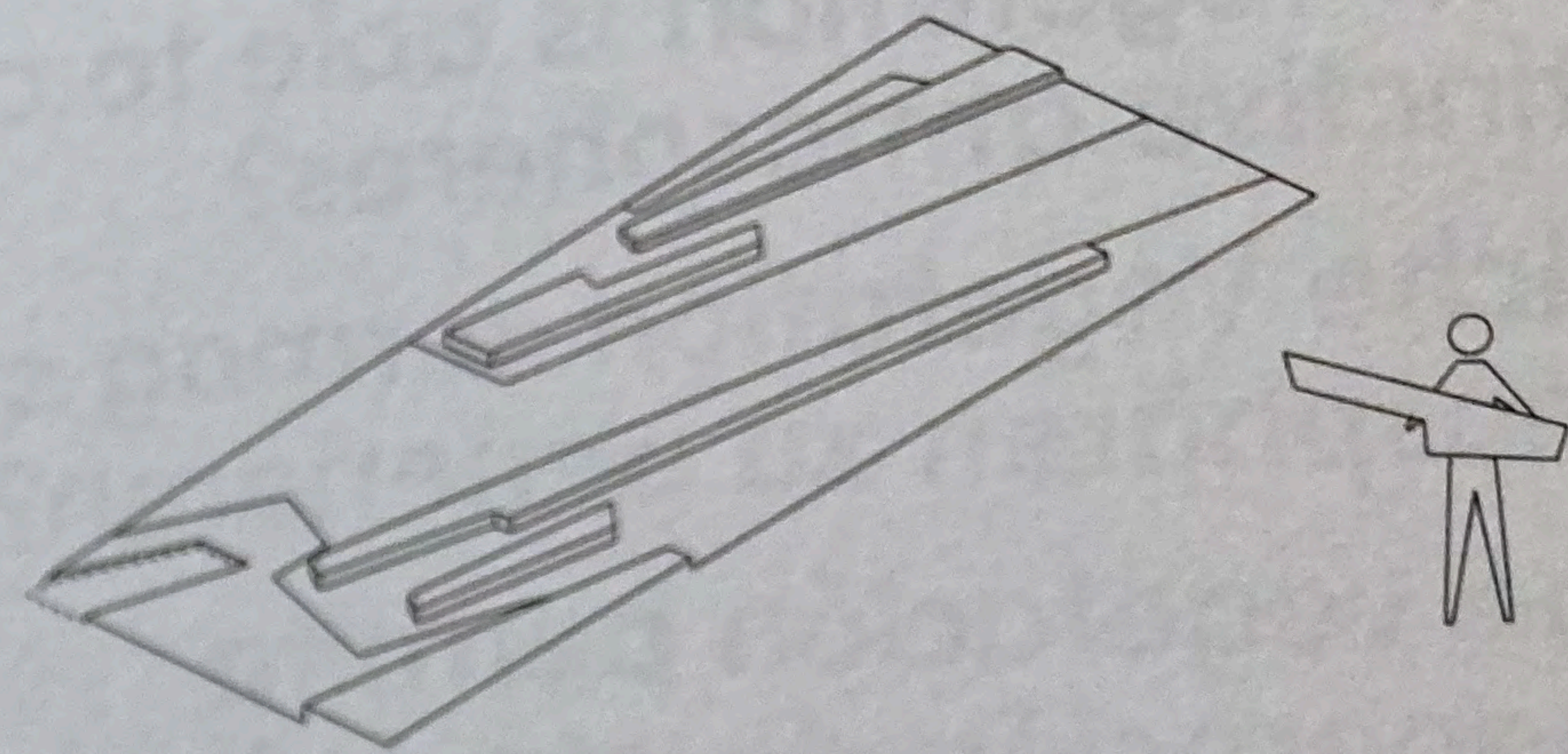

4.8

What kinds of events could the park host?

Welche Veranstaltungsangebote sind vorstellbar?

¿Qué tipo de eventos podría albergar el parque?

- Villa Reale di Marlia, Teatro di Verdura, Olivieri and Lelio Orsetti, 1652; Jaques Gréber, 1924
- Großer Garten Herrenhausen, Brand Westermann + Martin Charbonnier, 1692
- Schloss und Park Rheinsberg, Prinz Heinrich von Preußen, 1758
- Mauerpark, Gustav Lange, 1995
- Natur-Park Südgelände, ÖkoCon + Planland + Gruppe Odious, 1999
- 06 MFO-Park, Planergemeinschaft Burckhardtpartner / Raderschall, 2001
- Cultuurpark Westergasfabriek Park, Gustafson Porter + Bowman, 2004
- Allerpark, Büro Kiefer, 2004
- 08 Swiss Cottage Open Space, Gustafson Porter + Bowman, 2006
- Normand Park, KLA, 2008
- Archstoyanie Park, Wagon Landscaping, 2008 –
- 10 Father Collins Park, Fernando Abelleiro + Mauro Romero, 2009
- Sugar Beach, Claude Cormier + Associés, 2011
- Baakenpark, Atelier LOIDL, 2018

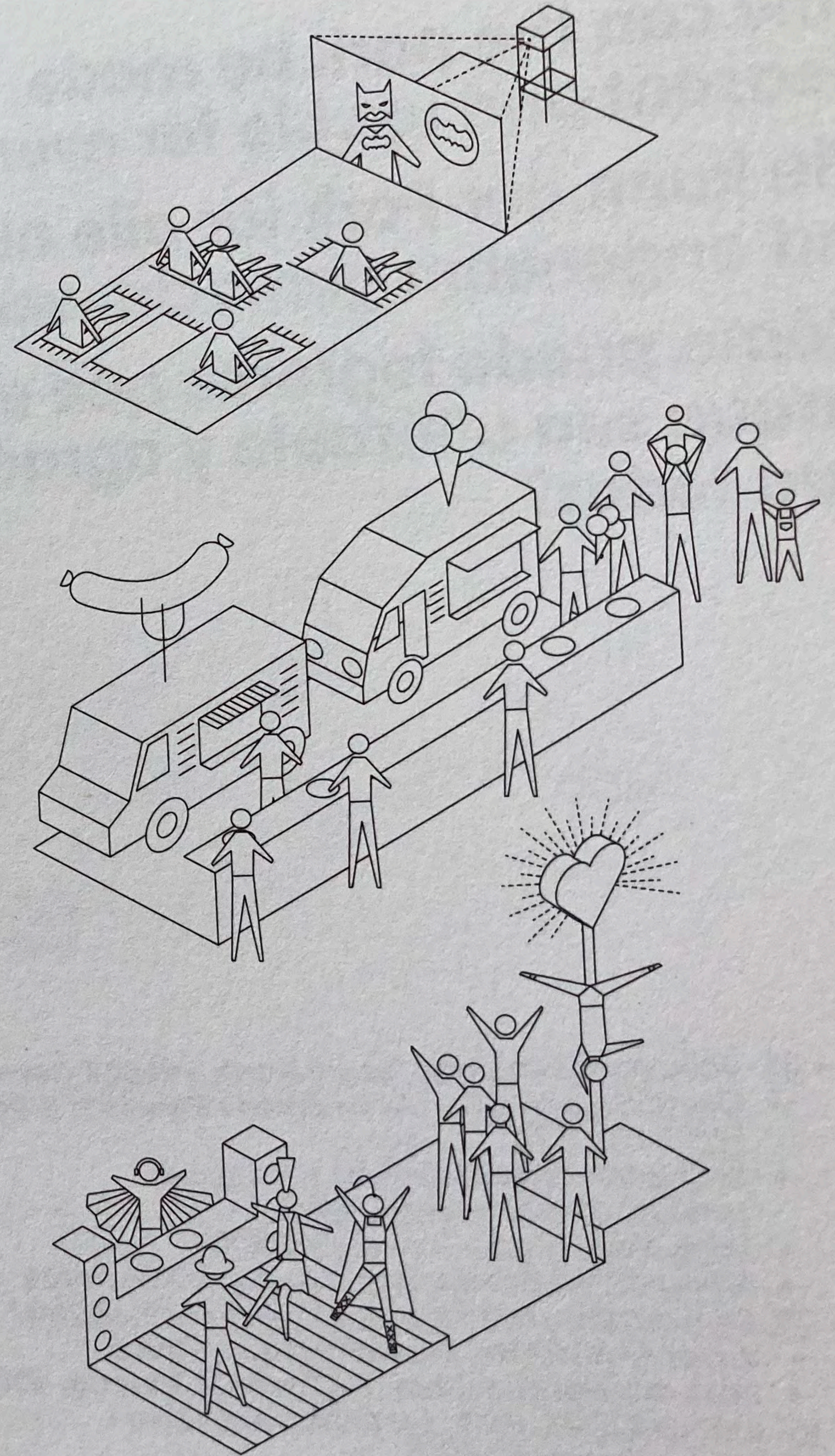

7.1

How intricate or expansive is the park? How many different areas does it have?

Wie kleinteilig oder großräumig ist der Park, wie viele Bereiche hat er?

¿Cómo de compartimentado o de unitario es el parque? ¿Cuántas zonas alberga?

- Park Sanssouci, Peter Joseph Lenné, 1744
- 01 Volkspark Rehberge, Erwin Barth + Rudolf Germer, 1929
- Sissinghurst Castle Garden, Vita Sackville-West, Harold Nicolson, 1930–1960
- 04 Geometrical Garden, Carl Theodor Sørensen, 1945–1984
- Brühlpark, Stöckli Kienast & Koeppel Landschaftsarchitekten, 1982
- Burnett Park, PWP Landscape Architecture, 1993
- Dania Park, Thorbjörn Andersson, 1999
- Ankarparken, SLA, 2001
- Botanical Garden of Bordeaux, mosbach paysagistes, 2002
- Lene-Voigt-Park, Büro Kiefer, 2004
- Hermann-Blankenstein-Park, Büro Kiefer, 2005
- Seafront, Prodromos Nikiforidis + Bernard Cuomo Architects, 2006
- Jardins d'Éole, Atelier Corajoud, 2006
- Teardrop Park, MVVA, 2006
- Zwei Parks auf dem Friedrichswerder, Büro Kiefer, 2008
- Hafenpark, sinai, 2015
- L'enfance du Pli, Gilles Brusset, 2017
- PIXELAND, 100architects, 2019

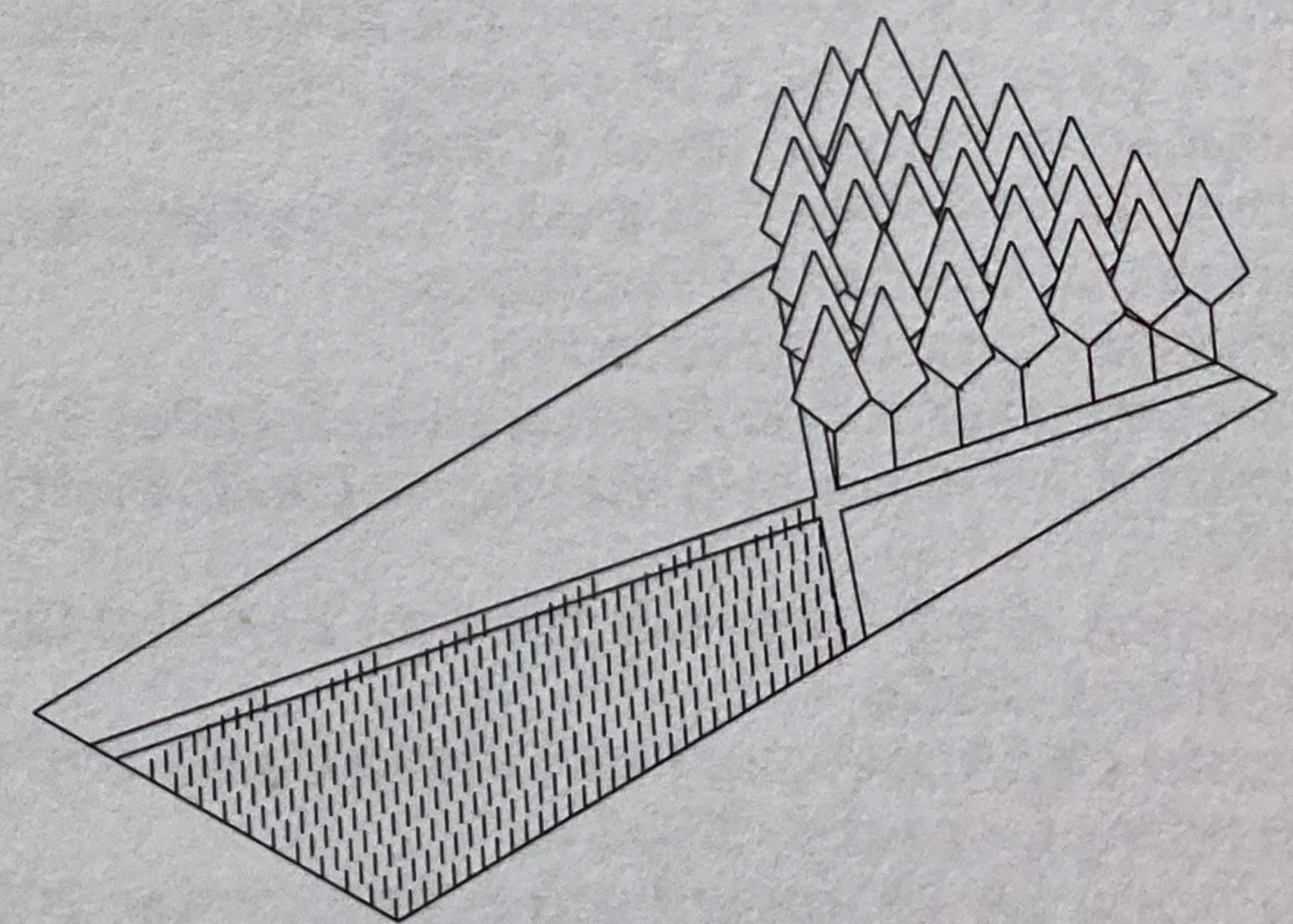
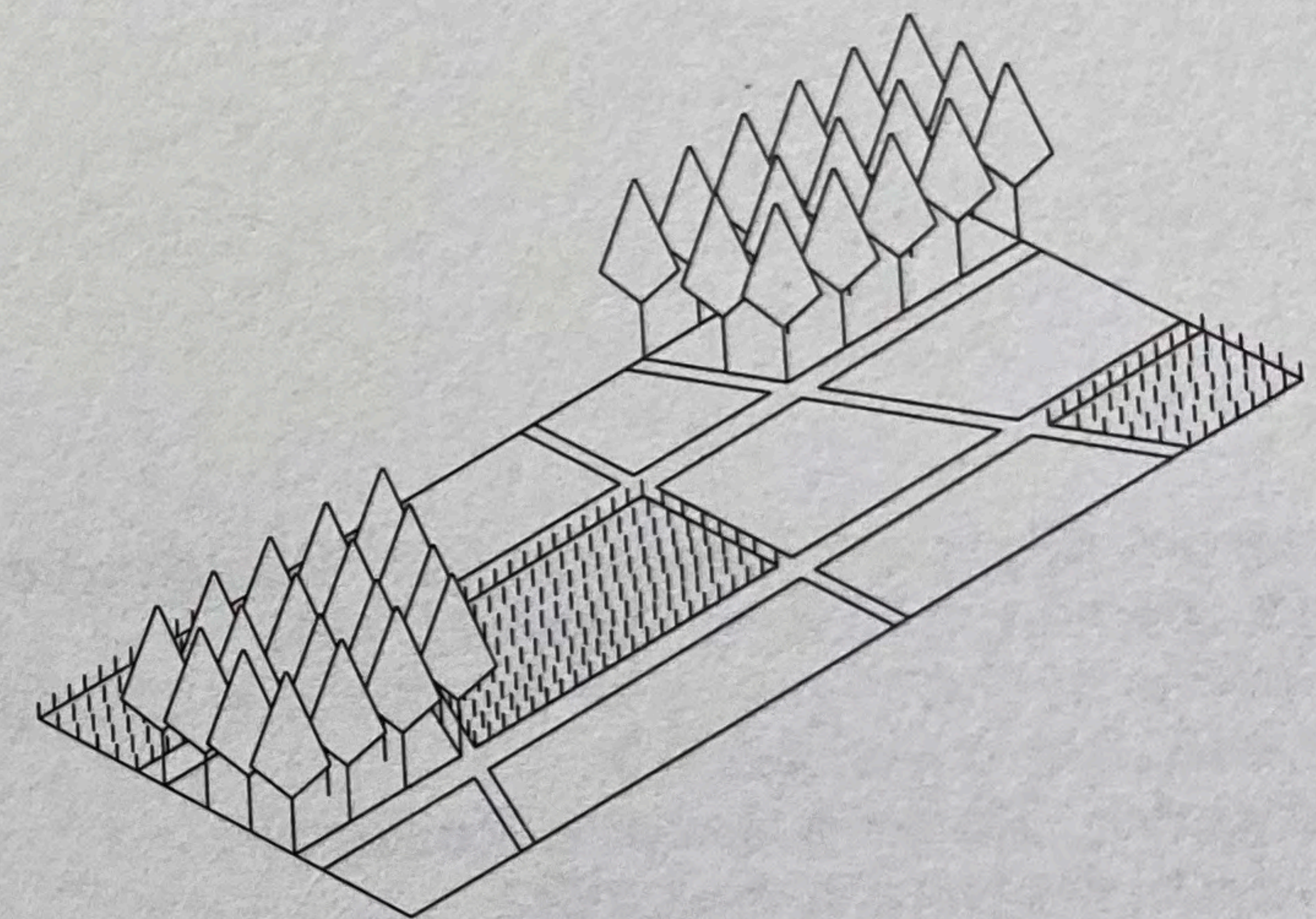
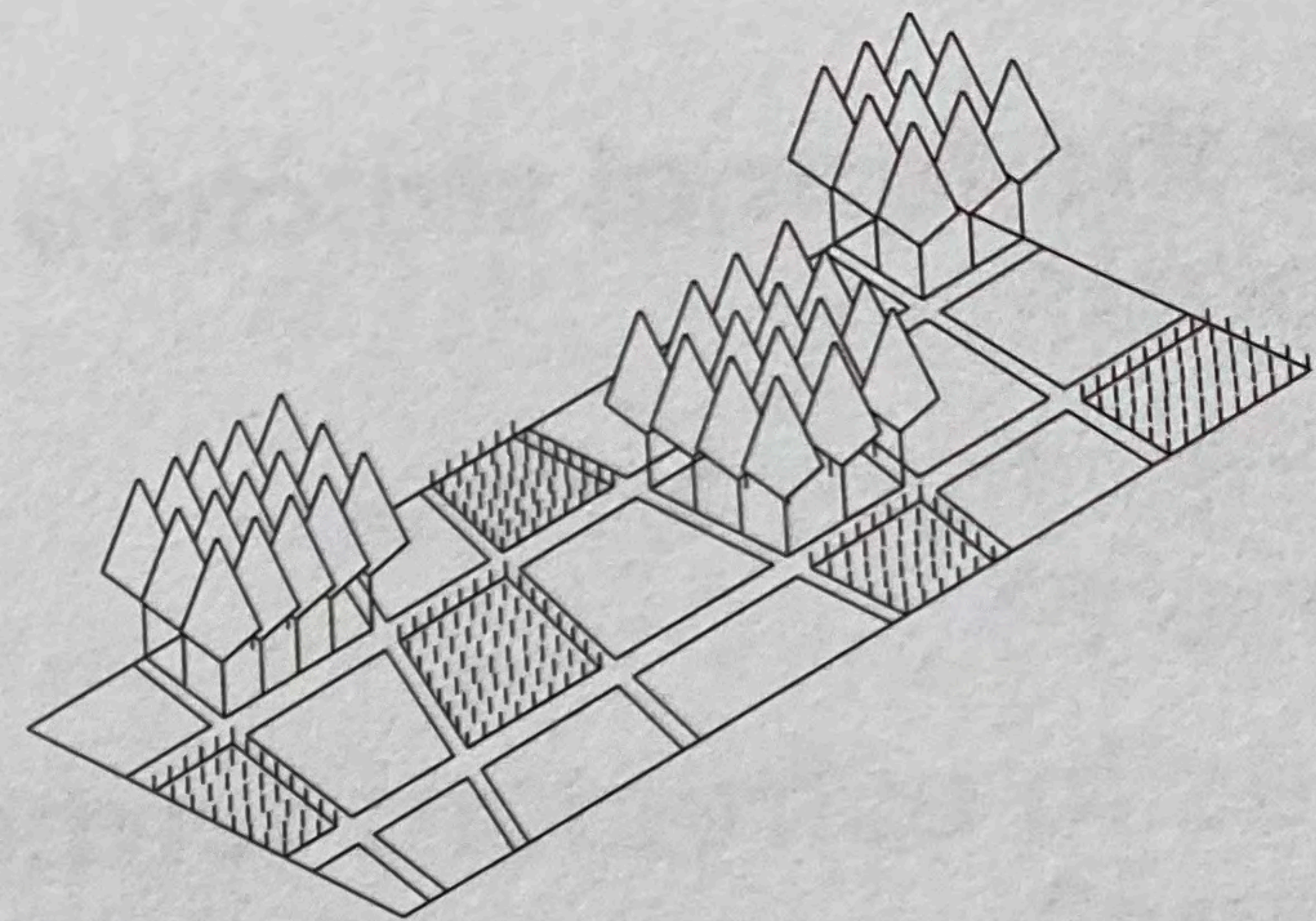

3.8
Is a park used intensively
or extensively?

Wird ein Park intensiv
oder extensiv genutzt?

¿Tiene el parque un uso
intensivo o extensivo?

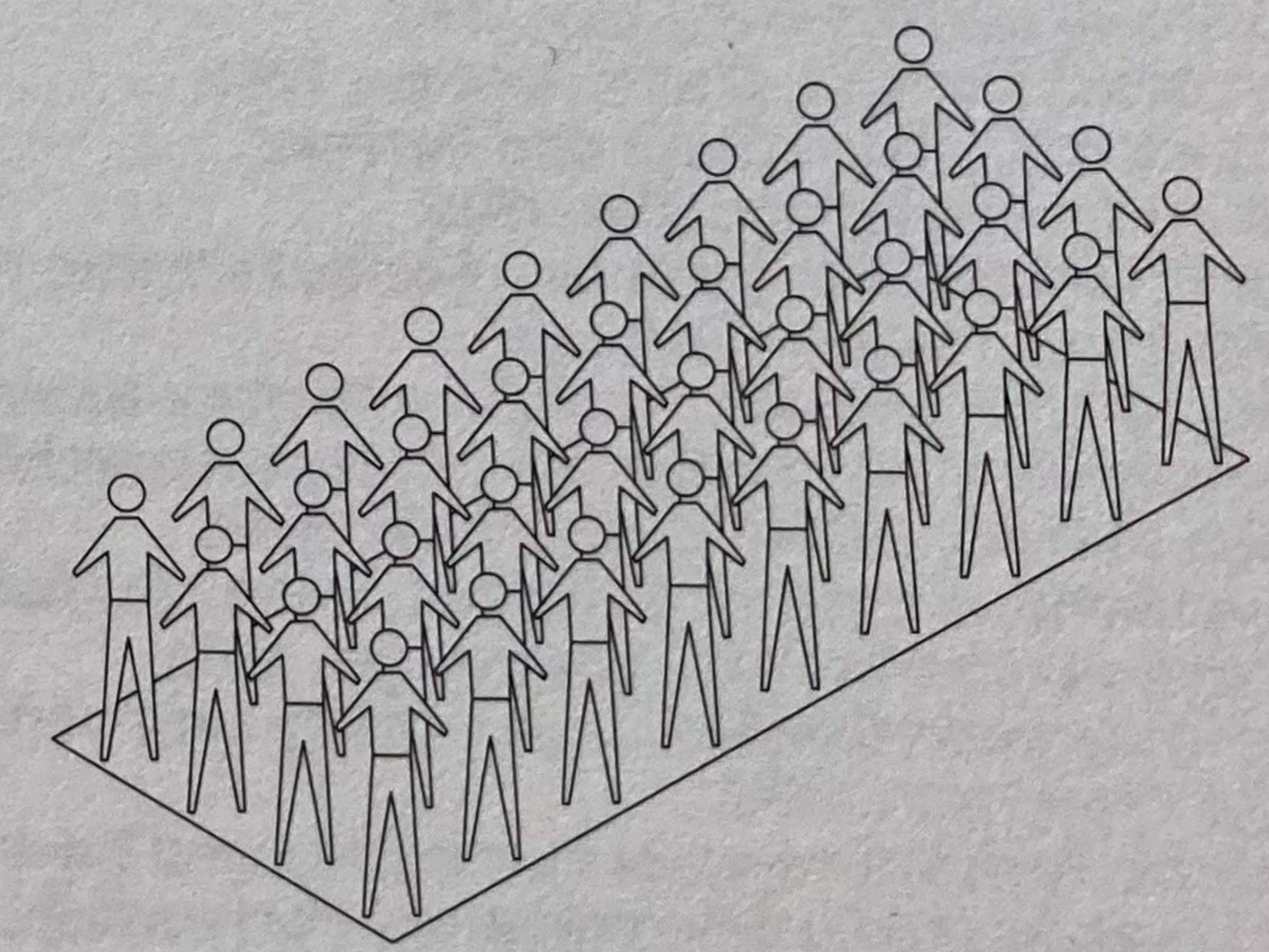
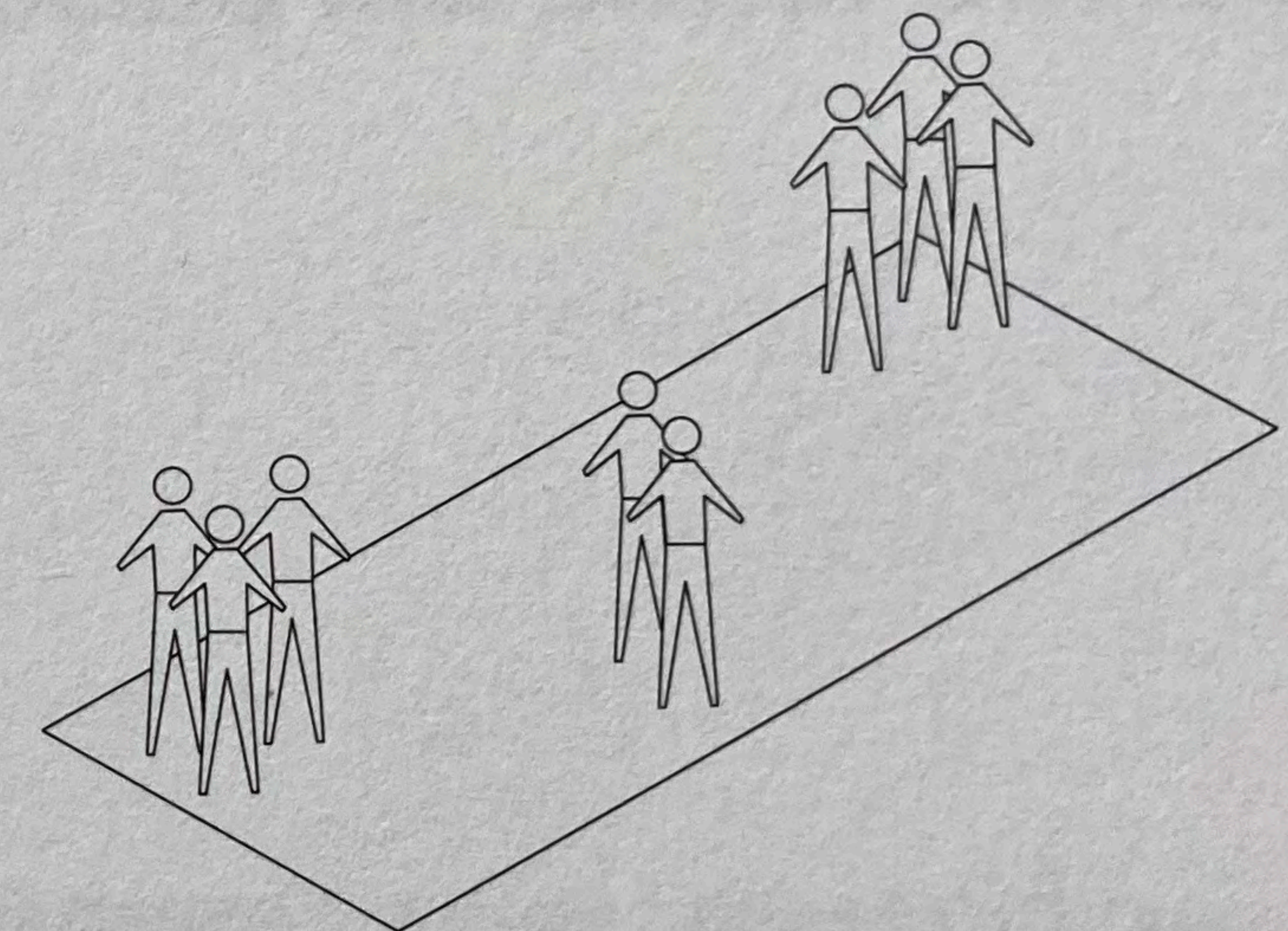
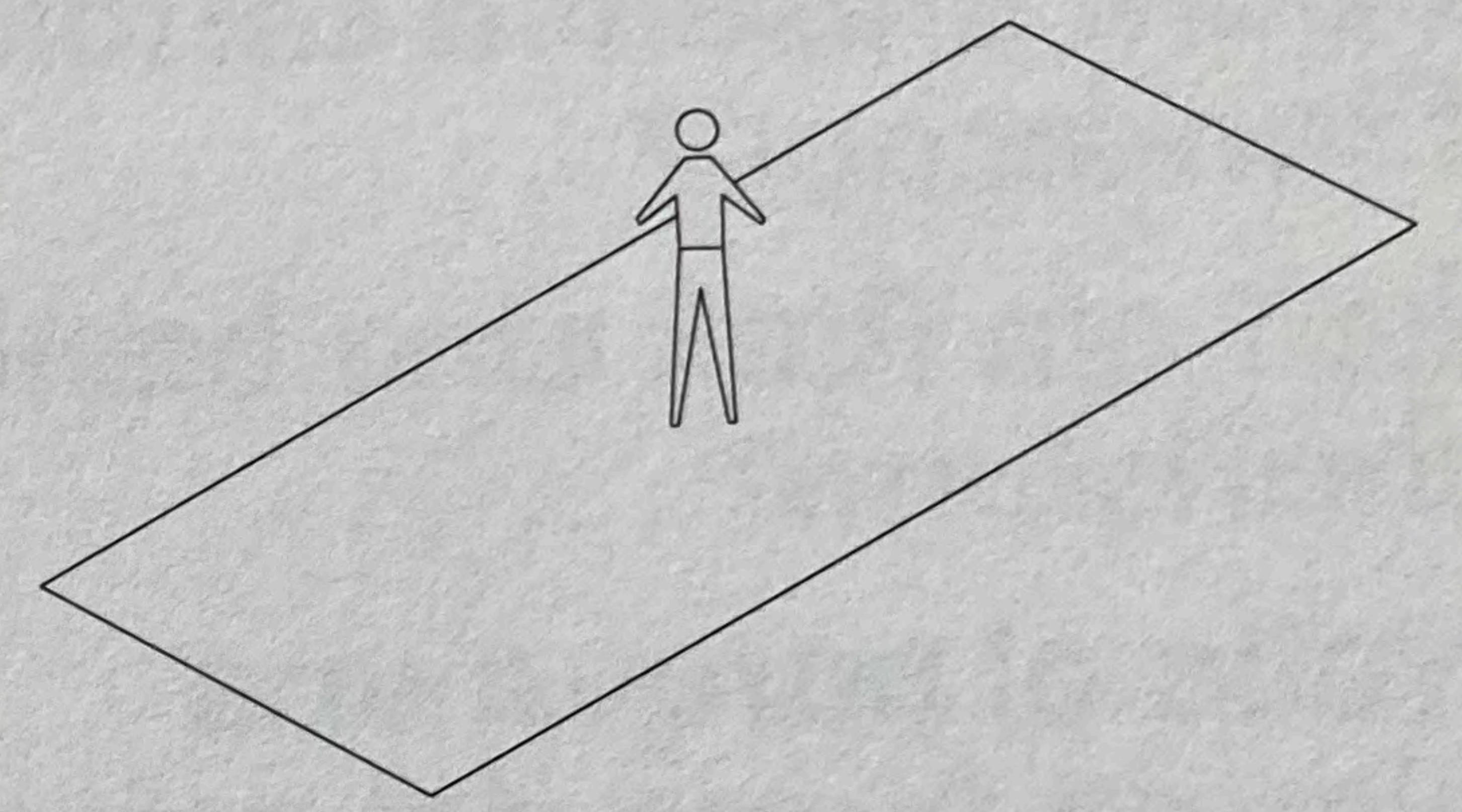

- Jardin du Luxembourg, Jacques Boyceaux et al., 1612;
 André Le Nôtre, 1642; Jean-François-Thérèse Chalgrin, 1798
- Hyde Park, Decimus Burton, 1825
- Central Park, Frederick Law Olmsted + Calvert Vaux, 1873
- Parc du Sausset, Atelier Corajoud, 1981
- Parc del Clot, Dani Freixes, Vicente Miranda, 1986
- Irchelpark, Atelier Stern und Partner, Eduard
 Neuenschwander, 1986
- Mauerpark, Gustav Lange, 1995
- Natur-Park Südgelände, ÖkoCon + Planland +
 Gruppe Odious, 1999
- Waldpark, Bureau B+B, 2001
- 07 Landschaftspark Riem, Latitude Nord, 2005
- Potters Fields Park, GROSS.MAX. + Piet Oudolf, 2007
- 09 Opfikerpark, Büro Kiefer + Hager Partner, 2007
- Jiang Yang Fan Ecopark, Beijing Forestry University,
 Atelier DYJG, 2010
- Qunli Stormwater Park, Turenscape, 2010

3.6

How can technical infrastructure be integrated in the landscape?

Wie können technische Bauwerke in die Landschaft integriert werden?

¿Cómo pueden integrarse las obras de naturaleza técnica en el paisaje?

- Canal du Midi, Pierre-Paul Riquet, 1681
- Taum Sauk Dam, United Electric, 1964
- Glen Canyon Dam, Bureau of Reclamation, 1964
- Aurland Hydro Power Plant, Toralf Lønrusten, 1966
- Wind Shield Calandkanaal, Maarten Struijs + Frans de Wit, 1985
- Rainwater retention basin Morbras, Gustafson Porter + Bowman, 1986
- Maeslantkering, HBG Constructors, 1990
- 03 Storm Surge Barrier, West 8, 1992
- 06 Restauració paisatgística de la Vall d'en Joan, Batlle i Roig, 2002
- Viaduc de Millau, Michel Virlogeux + Norman Foster, 2004
- Connecticut Water Treatment Facility, Michael Van Valkenburgh Associates, 2005
- Fort Honswijk, OKRA, 2009
- 08 Plan maestro de Reconstrucción Sustentable Constitución, Elemental, 2010
- 10 Buitenschot Park, H+N+S Architects, 2013
- 12 Renaturation of the River Aire, Studio Descombes Rampini, Superpositions, 2015
- Neuf écluses à Fonseranes, Alep, 2017
- Pumpspeicherkraftwerk, BGHplan Umweltplanung und Landschaftsarchitektur, 2020

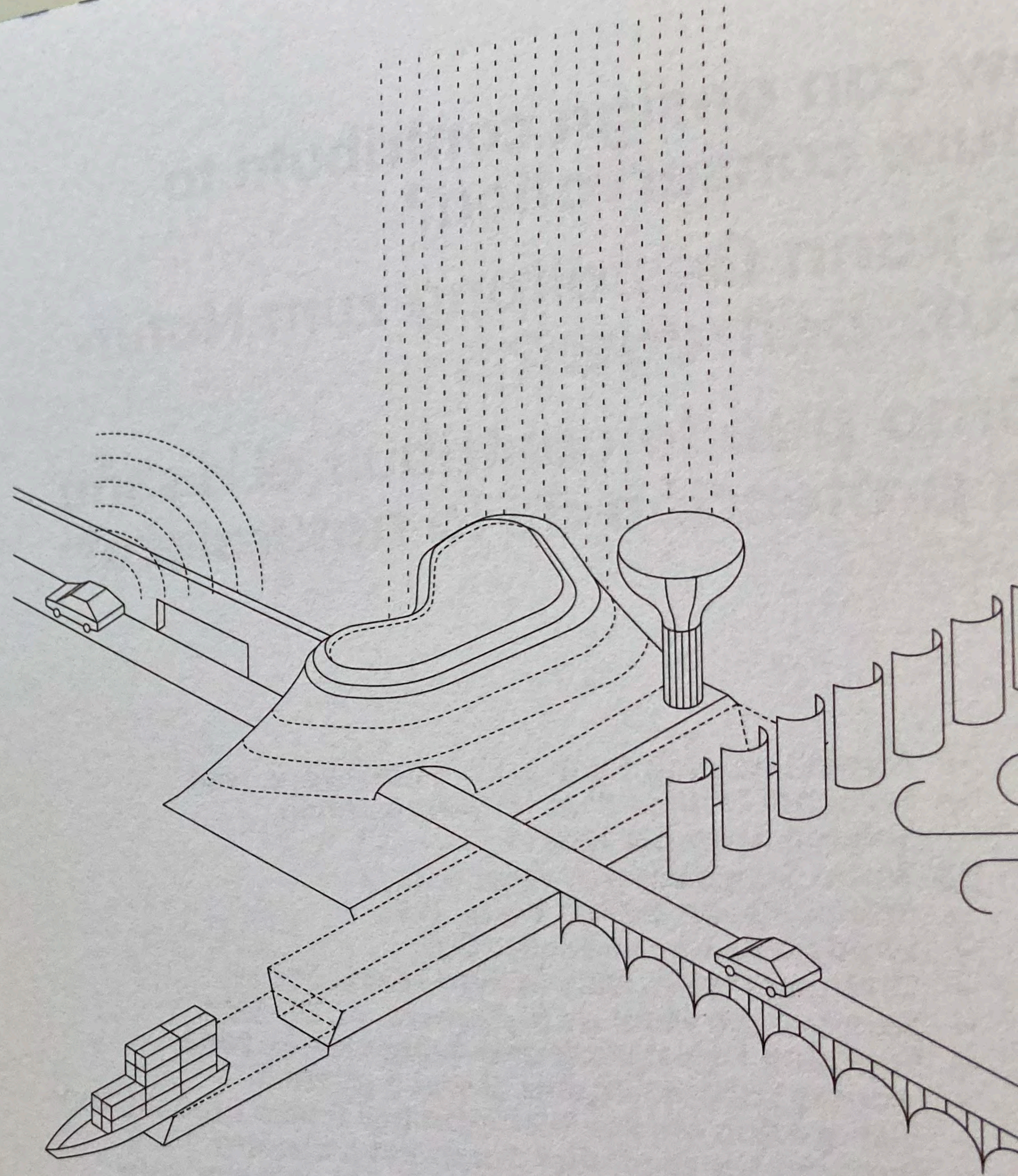

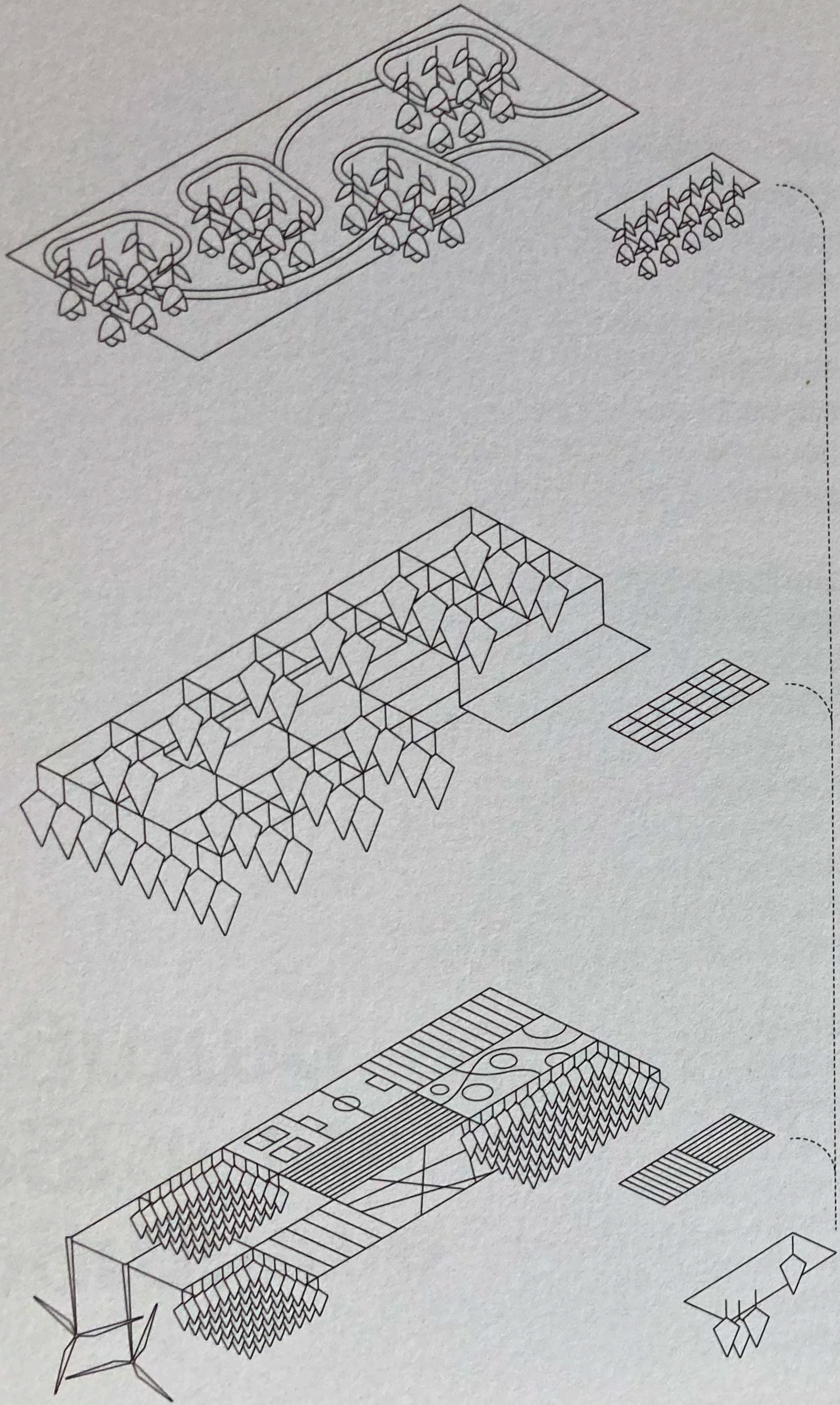

3.10
 How do park hybrids arise?
 Wie entstehen Parkhybride?
 ¿Cómo se producen los parques híbridos?

- 02 Jim Ellis Freeway Park, Lawrence Halprin + Angela Danadjileva, 1967
- Skyline Park, Lawrence Halprin, 1970
- Olympiapark, Günther Grzimek + Behnisch & Partner, Frei Otto, 1972
- Parc de la Pegaso, Batlle i Roig, 1986
- Parc François Mitterrand, Desvigne & Dalnoky, 1994
- Invalidenpark, Atelier Phusis + Christophe Girof, 1997
- Parc de la Villette, Bernard Tschumi, 1998
- Parc Agricole, Kamel Louafi, 2000
- 06 MFO-Park, Planergemeinschaft Burckhardtpartner / Raderschall, 2001
- Oerliker Park, Zulauf Seippel Schweingruber + Haerle Hubacher Architekten, 2001
- Parc de Pedra Tosca, RCR Arquitectes, 2004
- Floorworks, Agence Ter, 2005
- 09 Optikerpark, Büro Kiefer + Hager Partner, 2007
- Parque Sa Riera, Ravellat Ribas, 2007
- Parque Metropolitano del Agua, aldaylover arquitectura y paisaje, Christine Dalnoky, 2008
- Victor Civita Park, Benedito Abbud, 2008
- Estonian Road Museum, Saito Architects, 2010
- Sportanlage Heerenschürli, Topotek 1, 2010
- Park PHOENIX West, lohrer.hochrein, 2012
- Rabalder Park, Nordarch, 2013
- Saint-Jacques Ecological Park, Atelier de paysages Bruel-Delmar, 2013
- PIXELAND, 100architects, 2019

Does the park have to be practically finished or can it evolve successively?

Muss ein Park annähernd fertig werden oder darf er sukzessive wachsen?

?Debe un parque entregarse casi acabado o crecer progresivamente?

- Amsterdamsse Bos, Cornelis van Eesteren + Jakob Mulder, 1930
- Irchelpark, Atelier Stern und Partner, Eduard Neuschwander, 1986
- Oerliker Park, Zulauf Seippel Schweingrubber + Haerle Hubacher Architekten, 2001
- Alter Flugplatz Bonames, GTL Landschaftsarchitekten, 2004
- Garten KW Institute for Contemporary Art 01-04, 2004
- Atelier le Balto, 2004-2007
- Fresh Kills Lifescape, James Corner Field Operations, 2007-
- Archstoyanie Park, Wagon Landscaping, 2008-
- Botteskerkpark, Karres en Brands, 2009
- Greenwich Peninsula, Christine Dalnoky, MDP Michel Desvigne Paysagiste, 2010
- Jiang Yang Fan Ecopark, Beijing Forestry University, Atelier DYJG, 2010
- Jardin de la Connaissance at Gardenfestival Quebec, Thilo Folkerts, Rodney Latourelle, 2011
- Lieberoser Heide, Fugmann Janotta Partner, 2014
- Martin Luther King Park, Jacqueline Osty, 2014

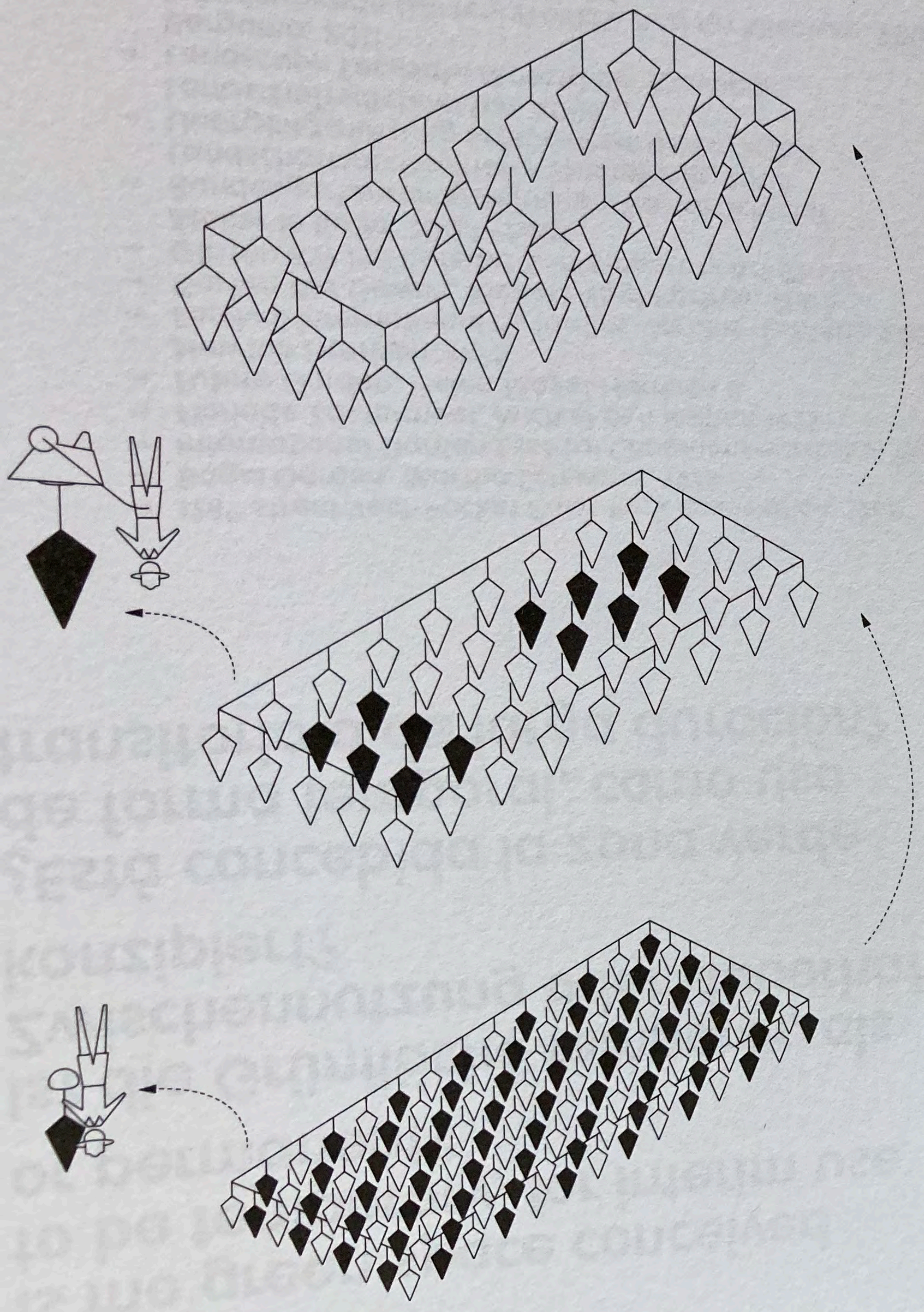

How do parks differ according to their users?

Wie unterscheiden sich Parks nach Nutzern?

?Cómo se diferencian los parques por sus usuarios?

- Parc de Chantilly, André Le Nôtre, 1673
- Park Sanssouci, Peter Joseph Lenné, 1744
- Stadtpark Hamburg, Fritz Schumacher + Ferdinand Sperber + Otto Linne, 1914
- Little Sparta, Ian Hamilton & Sue Finlay, 1966
- Garden of Cosmic Speculation, Charles Jencks, 1990
- Mauerpark, Gustav Lange, 1995
- Natur-Park Südgelände, OkoCon + Planland + Gruppe Odious, 1999
- Parc des Cormailles, Agence Ter, 2006
- Auwaldpark, huttreimann Landschaftsarchitektur, 2008
- Sportanlage Heerenschürli, Topotek 1, 2010
- PIXELAND, 100architects, 2019

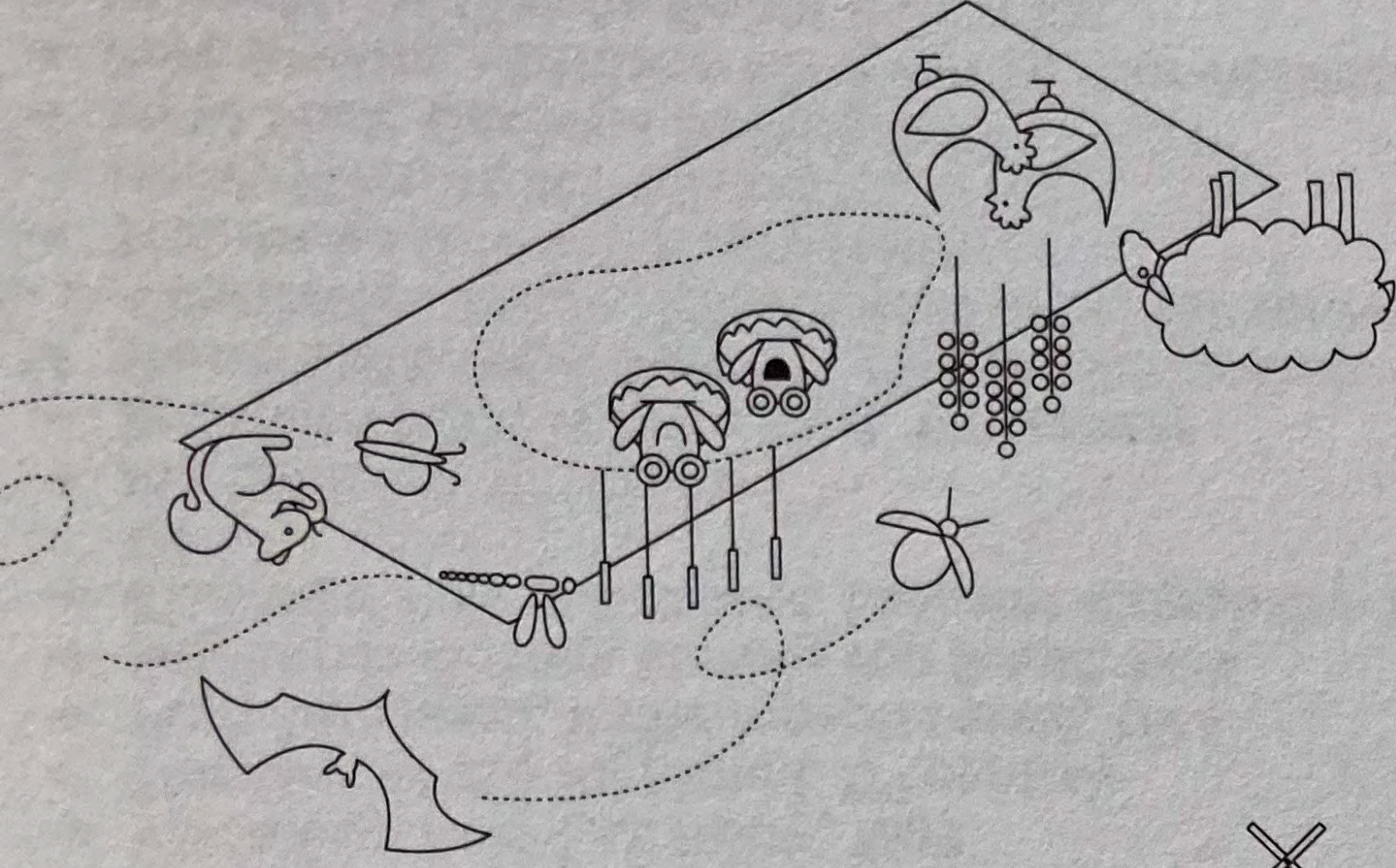
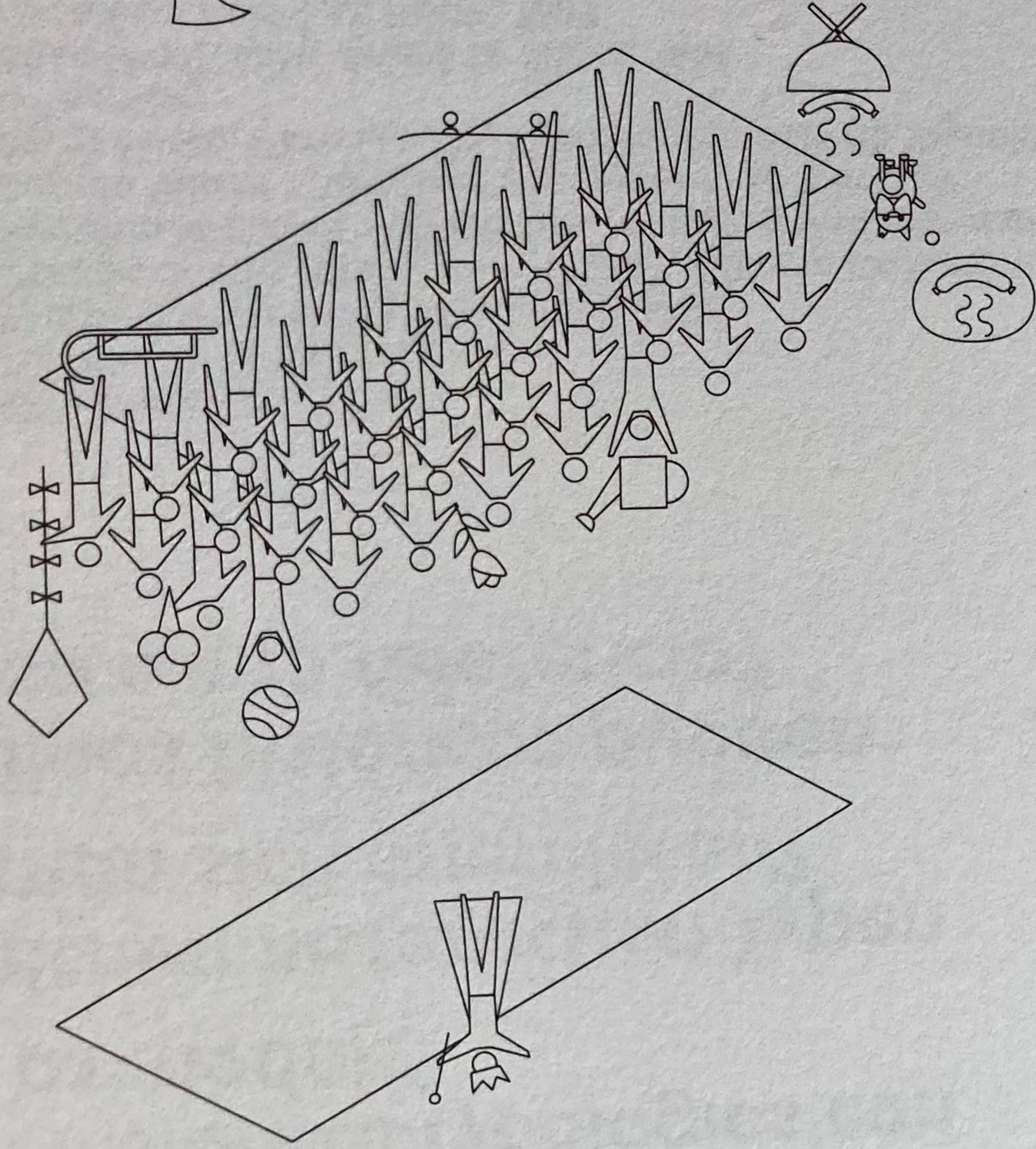

3.14

How can one promote biodiversity?

Wie kann Artenvielfalt gefördert werden?

¿Cómo puede promoverse la diversidad?

- Sugarloaf Key Bat Tower, 1983
- National Library, Dominique Perrault Architectes, 1995
- Crosswinds Marsh Wetland, SmithGroup, 1995
- Geschäftshaus Mühlebachstrasse, Kienast Vogt Partner + Romero + Schaeffe, 2001
- European Green Belt, 2004–
- Home of Fifa, Vogt Landschaftsarchitekten + Tilla Theus und Partner, 2006
- High Line, James Corner Field Operations + Piet Oudolf + Diller Scofidio + Renfro, 2009
- Park am Nordbahnhof, Fugmann & Janotta, 2009
- Lettenviadukt und Josefwiese, Studio Vulkan, 2010
- Beyond the Hive, Arup Associates, 2010
- Baden-Württemberg blüht, Villa Reitzenstein, 2012
- Honeycomb Bee Hotel, AtelierD, 2013
- École des Sciences et de la Biodiversité, Chartier Dalix Architectes, 2014
- Lieberoser Heide, Fugmann Janotta Partner, 2014
- Hotel d’Insectes, Batlle i Roig, 2016
- Jardin de Joyeux, Wagon Landscaping, 2016
- Walthamstow Wetlands Nature Reserve, KLA, 2017
- Hublandpark, hutterreimann Landschaftsarchitektur, 2018
- Fundo Tic Toc, Reed Hilderbrand LLC Landscape Architecture, 2018

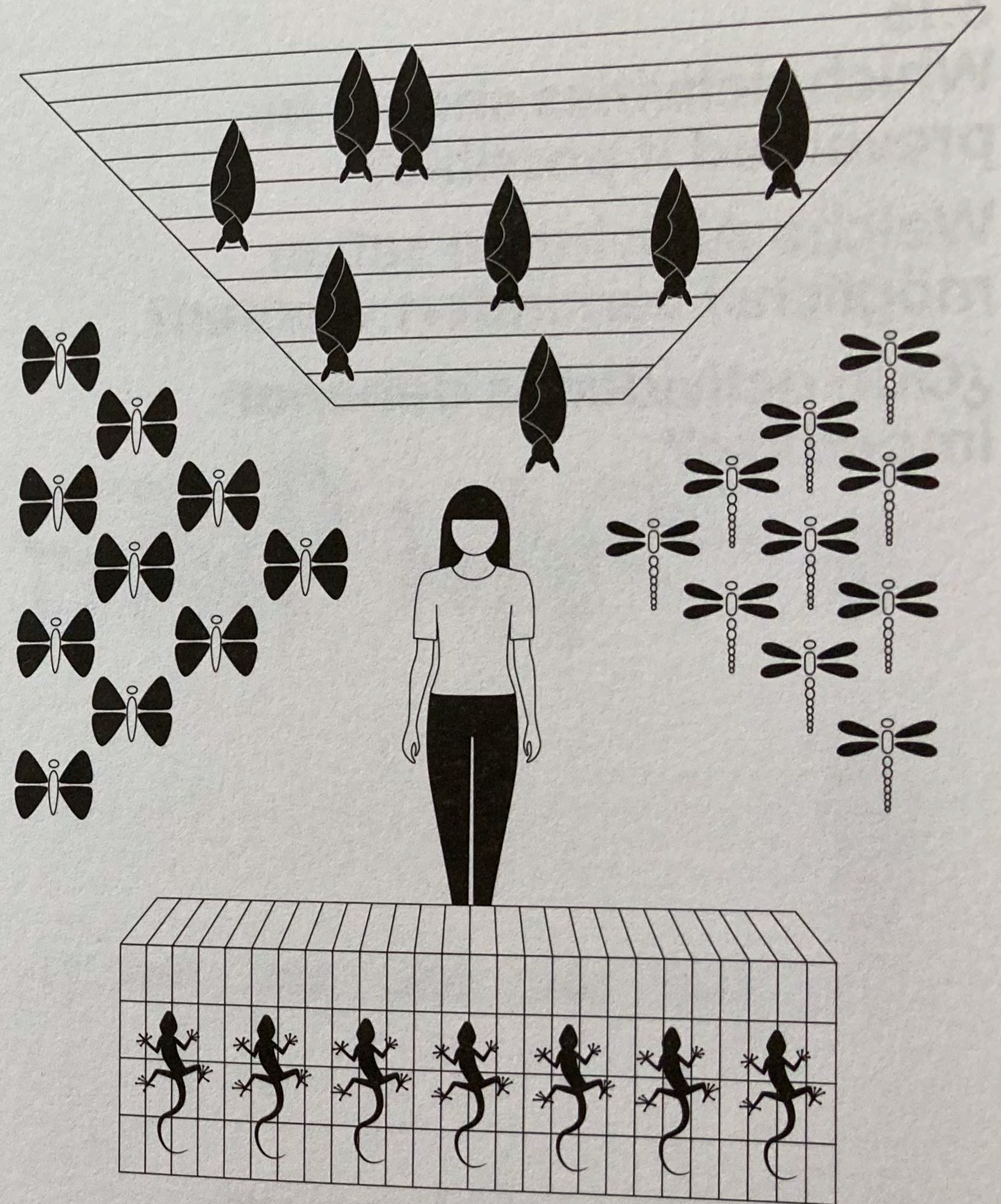

7.7

Do the park's elements adhere to common formal principles?

Folgen die Elemente des Parks gleichen formalen Prinzipien?

¿Siguen los elementos del parque los mismos principios de diseño?

- Miller House and Garden, Eero Saarinen + Dan Kiley, 1957
- Olympiapark, Günther Grzimek + Behnisch & Partner, Frei Otto, 1972
- Monteiro Garden, Roberto Burle Marx, 1984
- Garden of Cosmic Speculation, Charles Jencks, 1990
- Museumsinsel Hombroich, Bernhard Korte + Erwin Heerich, 1993
- La Théols Park Issoudun, Desvigne & Dalnoky, 1994
- Interpolis Garden, West 8, 1998
- **05** Jardí Botànic, Bet Figueras + Carlos Ferrater, 1999
- Oerliker Park, Zulauf Seippel Schweingruber + Haerle Hubacher Architekten, 2001
- Ankarparken, SLA, 2001
- Neue Gärten auf dem Dycker Feld, RMP Landschaftsarchitekten, 2002
- Parc J. B. Lebas, West 8, 2004
- Parc de Pedra Tosca, RCR Arquitectes, 2004
- Parc dels Auditoris, FOA, 2004
- **07** Landschaftspark Riem, Latitude Nord, 2005
- Leutschenpark, Westpol LandschaftsArchitektur, 2008
- Lizard Log Parklands, Mac Gregor Coxall, 2011
- Mandela Park, Karres en Brands, 2011
- Minghu Wetland Park, Turenscape, 2012
- Jardins Rosa-Luxemburg, In Situ Architectes Paysagistes, 2014
- Gridgrounds, Openfabric, 2017

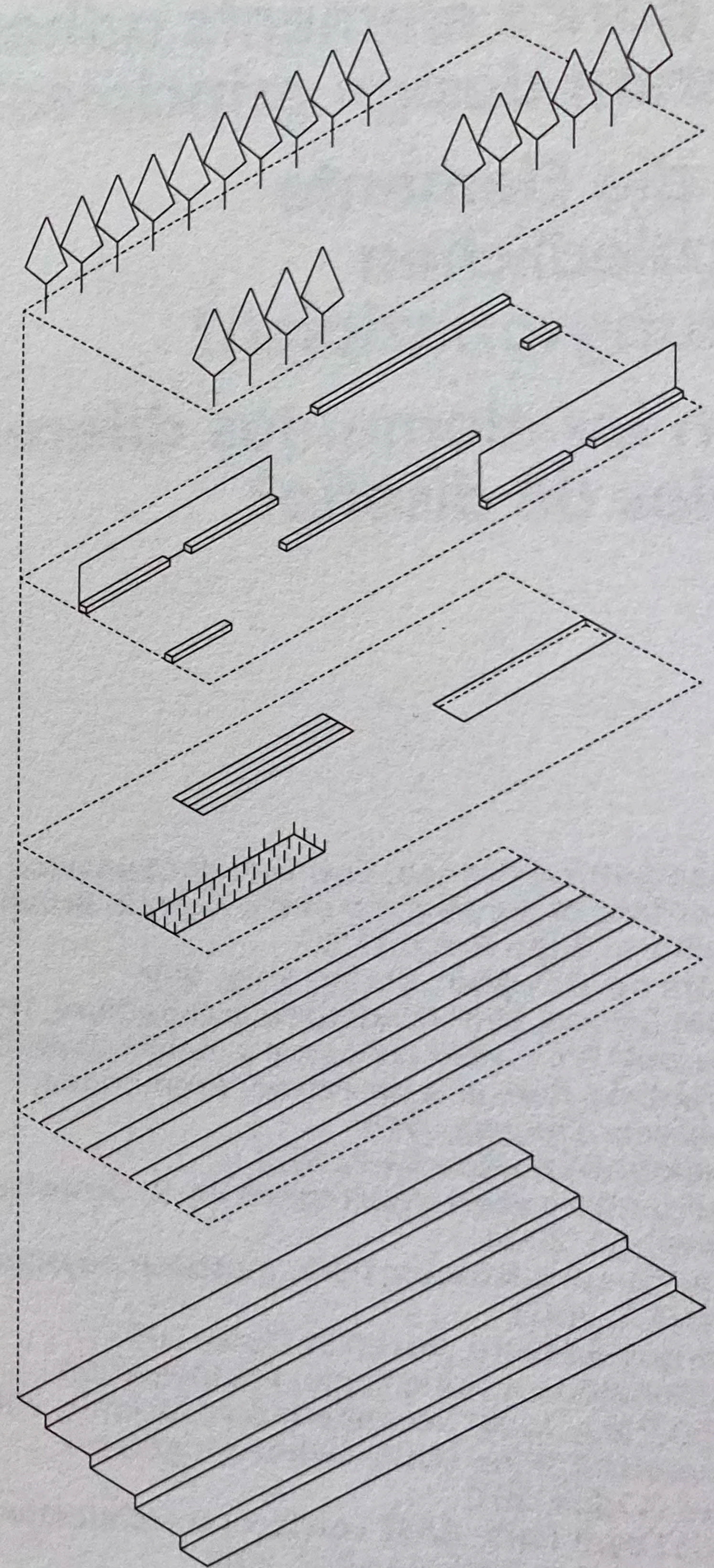

2.3

How can existing elements be incorporated into the design?

Wie kann Vorhandenes gestalterisch einbezogen werden?

¿Cómo puede lo existente integrarse de forma creativa?

- Tide Pool Saint Malo, René Lesaunier, 1937
- 02 Il Grande Cretto, Alberto Burri, 1985–2015
- National Outline Plan for Afforestation, Shlomo Aronson, 1986
- Weg der Schweiz, Georges Descombes, 1991
- Storm King Wall, Andy Goldsworthy, 1997–98
- The Crazannes Quarries, Bernard Lassus, 1997
- 04 Route der Industriekultur, 1998
- 05 Barnimer Feldmark, Atelier LOIDL, Plancontext, Schirmer und Kernbach, 2001
- Orongo Station, Nelson Byrd Woltz, 2002
- Shenyang Architectural University Campus, Turenscape, 2004
- Sky Garden, James Turrell, 2005
- Landschaftspark Riem, Latitude Nord, 2005
- Mountain Road Project, Jensen & Skodvin, 2005–2010
- Termas Geométricas, Germán del Sol, 2009
- Fort Honswijk, OKRA, 2009
- Jamaica Bay Project, Catherine Seavitt Nordenson, 2010
- Cap de Creus, EMF paisatge, 2010
- Adequació de l'espai natural del jaciment romà de Can Tacó, Toni Gironès Saderra, 2012
- Recuperació del sistema de reg a les hortes termals, Marta Serra Permanyer, Jordi Calbetó Aldomà, Elena Albareda Fernández, 2015
- 12 Renaturation of the River Aire, Studio Descombes Rampini, Superpositions, 2015
- Paiva River Boardwalk, Studio Trimétrica, 2015
- Bardolino Route, LAND, 2016–

