

David Bradley  
David W. Russell  
*Editors*

# Mechatronics in Action

Case Studies in Mechatronics –  
Applications and Education

 Springer

# Mechatronics in Action

David Bradley · David W. Russell  
Editors

# Mechatronics in Action

Case Studies in Mechatronics –  
Applications and Education

 Springer

*Editors*

David Bradley, Prof.  
University of Abertay Dundee  
Bell Street  
Dundee, DD1 1HG  
United Kingdom  
d.bradley@abertay.ac.uk

David W. Russell, Prof.  
The School of Graduate Professional Studies  
Penn State Great Valley  
30 East Swedesford Road  
Malvern, PA 19355  
USA  
drussell@psu.edu

ISBN 978-1-84996-079-3

e-ISBN 978-1-84996-080-9

DOI 10.1007/978-1-84996-080-9

Springer London Dordrecht Heidelberg New York

British Library Cataloguing in Publication Data

A catalogue record for this book is available from the British Library

Library of Congress Control Number: 2010924433

© Springer-Verlag London Limited 2010

The Trademark Blackberry is owned by Research In Motion Limited and is registered in the United States and may be pending or registered in other countries. Springer is not endorsed, sponsored, affiliated with or otherwise authorized by Research In Motion Limited.

COSMOSWorks® and SolidWorks® are registered trademarks of Dassault Systèmes SolidWorks Corp. da Vinci and Zeus are registered trademarks of Intuitive Surgical, Inc., 1266 Kifer Road, Building 101 Sunnyvale, CA 94086-5304, <http://www.intuitivesurgical.com/>

Inventor is a registered trademark or trademark of Autodesk, Inc., and/or its subsidiaries and/or affiliates in the USA and/or other countries. All other brand names, product names, or trademarks belong to their respective holders. Autodesk reserves the right to alter product offerings and specifications at any time without notice, and is not responsible for typographical or graphical errors that may appear in this document. © 2010 Autodesk, Inc. All rights reserved.

Windows Vista is either a registered trademark or trademark of Microsoft Corporation in the United States and/or other countries.

Apart from any fair dealing for the purposes of research or private study, or criticism or review, as permitted under the Copyright, Designs and Patents Act 1988, this publication may only be reproduced, stored or transmitted, in any form or by any means, with the prior permission in writing of the publishers, or in the case of reprographic reproduction in accordance with the terms of licences issued by the Copyright Licensing Agency. Enquiries concerning reproduction outside those terms should be sent to the publishers.

The use of registered names, trademarks, etc. in this publication does not imply, even in the absence of a specific statement, that such names are exempt from the relevant laws and regulations and therefore free for general use.

The publisher makes no representation, express or implied, with regard to the accuracy of the information contained in this book and cannot accept any legal responsibility or liability for any errors or omissions that may be made.

*Cover design:* eStudioCalamar, Figueres/Berlin

Printed on acid-free paper

Springer is part of Springer Science+Business Media ([www.springer.com](http://www.springer.com))

# Foreword

## The History of the Mechatronics Forum

Memiş Acar<sup>1</sup>

### *Origins*

The Mechatronics Forum came into existence at a meeting held at the Institution of Mechanical Engineer's (IMechE) London headquarters on the 30th of October, 1990, and was attended by over 70 individuals. The Forum was the first organisation in the Western world to recognise the importance of mechatronics and to promote it as an integrating engineering discipline.

Although the word Mechatronics has been around since 1969 – the term was coined by Mr. Tetsuro Mori, a senior engineer of the Japanese company Yaskawa – it was only in the early 1990s that it began to be used to any great extent in the UK. However since then, through the activities of the Mechatronics Forum, the term mechatronics and the engineering design philosophy that it encompasses has become widely recognised.

Mechatronics today extends beyond the integration of mechanical, electronic and computer engineering. Many engineers now see it as embracing a wider range of engineering activities, from design through manufacture to the market place. Hence, they regard mechatronics as a major influence in pulling together and integrating the many aspects of engineering which increased specialisation has tended to push apart over recent years.

It was in an attempt to solve this increasingly difficult problem that the Mechatronics Forum was conceived as a first step towards the building of bridges between the many technologies, philosophies and disciplines which comprise mechatronics and the professional institutions that are committed to their own particular specialised subjects.

In this context, the Mechatronics Forum initially operated under a series of inter-institutional arrangements, with secretarial and administrative services provided alternately by the Institution of Mechanical Engineers (IMechE) and the Institution of Electrical Engineers<sup>2</sup> (IEE). However, in recent years, this

---

<sup>1</sup> Loughborough University, UK

<sup>2</sup> Now the Institution of Engineering and Technology (IET)

relationship has changed on a number of occasions and it currently operates under the auspices of the IMechE.

### *Mechatronics Forum Committee and Its Chairs*

The founding Committee of the Mechatronics Forum was charged with a comprehensive portfolio of objectives including setting up and establishing a publication of a regular Newsletter, popularising mechatronics, focusing on educational issues, and seeking ways of bringing together all those interested in mechatronics, and especially of promoting closer links between industry and academia. These are still the objectives today, and significant advances have been made in relation to a number of them.

Today, the committee includes a number of members from outside the UK who help with the internationalisation of the Mechatronics Forum and its activities. To this end, the majority of its international biennial conferences have been held outside the UK.

The first Chair of the Mechatronics Forum was Professor Jack Dinsdale of the University of Dundee; the complete list of Chairs to the time of writing is:

1990	Professor Jack Dinsdale	University of Dundee
1993	Professor Jim Hewit	Loughborough University
1994	Professor Rob Parkin	De Montfort University
1995	Professor Tim King	The University of Birmingham
1996	Professor Phil Moore	De Montfort University
1997	Dr Memis Acar	Loughborough University
1998	Dr Klaus Selke	University of Hull
2000	Dr Memis Acar	Loughborough University
2004	Professor Geoff Roberts	Coventry University
2008	Professor Phil Moore	De Montfort University

### *Mechatronics Forum Conferences*

The Mechatronics Forum was the first professional group to organise conferences on this engineering field. The first conference was organised at Lancaster University in 1989 by Dr David Bradley<sup>3</sup> who was, along with Prof. Jack Dinsdale and Prof. Jim Hewit, one of the three leading founders of the Mechatronics Forum. Although the Mechatronics Forum did not exist then as an organisation, the concept was in the minds of its founders at the time of the Lancaster conference. Hence, it is proper to count this conference as the first of the Mechatronics Forum Conferences.

This first conference was followed by conferences in Cambridge (1990) and Dundee (1992). After holding the first three conferences in the UK, in 1994 the Mechatronics Forum held its first conference outside the UK, organised in

---

<sup>3</sup> Now Prof. David Bradley and one of the editors of this book

collaboration with the Technical University of Budapest, Hungary. With this initiative, Prof. Jim Hewit played a pivotal role in the internationalisation of the Mechatronics Forum Conferences. All subsequent conferences have been held outside the UK. The following is the complete list of the biennial Mechatronics Forum Conferences to the time of writing:

1989	1st Conference <sup>4</sup>	<i>Mechatronics in Products and manufacturing</i> Lancaster University
1990	2nd Conference <sup>3</sup>	<i>Mechatronics – Designing Intelligent Machines</i> IMEchE conference at Robinson College, Cambridge
1992	3rd Conference	<i>Mechatronics – The Integration of Engineering Design</i> University of Dundee, Dundee, Scotland
1994	4th Conference	<i>Mechatronics: the Basis for New Industrial Development</i> Technical University of Budapest, Budapest, Hungary
1996	5th Conference	University of Minho, Minho, Portugal
1998	6th Conference	University of Skövde, Skövde, Sweden
2000	7th Conference	Georgia Institute of Technology, Atlanta, USA
2002	8th Conference	University of Twente, Twente, The Netherlands
2004	9th Conference	Middle East Technical University, Ankara, Turkey
2006	10th Conference	Penn State University, Great Valley Campus, Malvern, USA
2008	11th Conference	University of Limerick, Limerick, Ireland
2010	12th Conference	ETH, Zurich, Switzerland

In addition, the Mechatronics Forum is organising the 10th International Workshop on Mechatronics Education and Research in (REM). This is a European network of universities active in mechatronics and the conference will be held in 2009 at the University of Strathclyde in Glasgow.

### *Mechatronics Forum Prestige Lectures*

One of the principal activities of the Mechatronics Forum has been the organisation of a series of Prestige Lectures. The lectures in this series to the time of writing are:

1995	<i>The Role of Xero-Mechatronics in New Product Development</i> Dr John F Elter of the Xerox Corporation
1996	<i>Advances in Mechatronics: the Finnish Perspective</i> Vesa Salminen of FIMET

---

<sup>4</sup> Both the 1st and 2nd conferences were held before the Mechatronics Forum was formally constituted, but were instrumental in its establishment and hence are included in the list of conferences. After the Robinson College conference, it was agreed that subsequent conferences should come under the auspices of the Mechatronics Forum and be held biennially.

- 1997 *The Industrial Benefits of Mechatronics: the Dutch Experience*  
Professor Job van Amerongen of the University of Twente
- 1998 *Virtual Worlds – Real Applications: Industrial and Commercial Developments in the UK*  
Professor Bob Stone of the University of Birmingham,
- 2000 *Mechatronic Solutions for Industry*  
Professor Rolf Isermann of the University of Darmstadt
- 2001 *Intelligent Mechatronics: Where to go?*  
Professor Toshio Fukuda of Nayaga University
- 2003 *Bionics: New Human Engineered Therapeutic Approaches to Disorders of the Nervous System*  
Professor Richard Normann of the University of Utah
- 2004 *GM's Approach to Eliminating Complexity and Making the Business More Successful*  
Dr Jeffrey D Tew of General Motor's R&D Center
- 2005 *Mechatronic Design Challenges in Space Robotics*  
Dr Cock Heemskerk & Dr Marcel Ellenbroek of Dutch Space
- 2006 *Cyborg Intelligence: Linking Human and Machine Brains*  
Professor Kevin Warwick of the University of Reading
- 2007 *Iterative Learning Control – From Hilbert Space to Robotics to Healthcare Engineering*  
Professor Eric Rogers of the University of Southampton
- 2008 *World Water Speed Record Challenge – The Quicksilver Project*  
Nigel Macknight, Team Leader and Driver, Quicksilver (WSR) Ltd
- 2009 *Meeting the Challenges and Opportunities of Sustainability Through Mechatronic Product Development*  
Professor Tim McAloone of the Technical University of Denmark

### *Mechatronics Forum Events*

The Mechatronics Forum also organises short one-day events on specific topics of interest for the benefit of its members. The following is a selection of the topics covered over the years:

- 1991 *Mechatronic Design for the Machining of Exotic Materials*  
Seminar held at Leicester Polytechnic<sup>5</sup>
- 1994 *Mechatronics – the Japanese Way*  
Colloquium held at the IMechE in London
- 1995 *Innovative Actuators for Mechatronics Systems*  
Colloquium held at the IEE Savoy Place in London

---

<sup>5</sup> Now De Montfort University



- 1996 *Mechatronics Education*  
Colloquium held at Manchester Metropolitan University
- 1996 *Mechatronics in Automated Handling*  
Royal Mail Technology Centre, Swindon
- 1996 *The Industrial Benefits of Mechatronics: The Scandinavian Experience*  
Colloquium held at the IEE headquarters at Savoy Place in London
- 1996 *Process Control and Robotics*  
IMechE in London
- 1997 *Mechatronic Systems*  
Workshop with Professor Rolf Isermann of Darmstadt University held at the IEE headquarters at Savoy Place in London
- 1997 *Intelligent Machines and Systems: the Implications for Mechanical Engineering*  
Workshop with Professor George Rzevski of the Open University held at the IMechE in London
- 1997 *Design of Modern Manufacturing Machinery*  
Colloquium held at the IMechE in London
- 1997 *Total Design of Mechatronics Systems*  
Workshop held at the University of Bath
- 1998 *Choosing and Using PLCs*  
Colloquium held at the IEE Savoy Place and the University of Birmingham
- 1998 *Learning from the Japanese Experience*  
Colloquium held at the IEE Savoy Place in London
- 1998 *Mechatronics Mini Symposium*  
Symposium at the IMechE Control 98 Conference at the University of Wales, Swansea
- 2002 *Future Trends in Robotics*  
Seminar at the IMechE in London
- 2003 *Mechatronics in Medicine*  
Symposium at Loughborough University
- 2008 *Robotics in Medicine*  
Symposium at the IMechE in London

### *Mechatronics Forum Technical Visits*

Over the years, the Mechatronics Forum organised a number of technical visits to leading companies for its members. The following is a selection of some of the companies visited:

Alcan (Bridgenorth)	Analog Devices (Limerick)
BAe Warton	Brinton Carpets, Kiddeminster
British Aerospace (Brough)	British Nuclear Fuels (Springfields)

British United Shoe Machinery (Leicester)	Cirrus Technologies (Redditch)
Control Techniques (Newtown, Powys)	Cranfield University CIM Institute
Cybernetics Institute, University of Salford	Defense Research Agency (Chertsey)
Exitech (Oxford)	FeONIC Plc, University of Hull
Flymo (County Durham)	Ford (Dagenham)
IBM (Greenock)	Komatsu (Redditch)
Lucas Advanced Engineering Centre (Shirley)	Mars Confectionery (Slough)
Mitsubishi Technology Centre (Hatfield)	Motorola (Easter-Inch, Edinburgh)
NCR (Dundee)	National Oceanographic Centre (Southampton)
Pioneer Electronics (Castleford)	Rank Taylor Hobson (Leicester)
Renishaw Metrology (Wotton-under-Edge)	Rover Powertrain Division of Rover Cars Ltd.
Royal Mail Technology Centre (Swindon)	Salford Advanced Robotics Research Centre
Siemens (Oxford) Magnet Technology	University of Hull
Yamazaki Mazak Machine Tools (Worcester)	

### *Mechatronics Student of the Year Award*

The Mechatronic Forum also offers the Mechatronics Engineering Student of the Year Award, which has been specifically designed to help raise the profile of mechatronics design philosophy and mechatronics engineering education. The award provides a showcase for educational excellence by publicly recognising and rewarding the exceptional achievements of both students and universities. The competition is based around a submission of student's individual final year project report, or the group project report.

Entries are required to demonstrate:

- the application of mechatronics design philosophy to a specific engineering problem;
- an economically feasible solution in terms of its potential application in industry;
- excellent research and development practice, and final presentation.

The top three to five entrants are normally invited to the Finals where each student is required to present their project to the judges, who themselves are all engineers working in mechatronics.

# Preface

Geoff Roberts<sup>1</sup>

Worldwide interest in *mechatronics* and its associated activities continue to grow annually. One indicator of this growth is the large number of mechatronics-based conferences on offer. When the first of what became the Mechatronics Forum conferences was organised in 1989, this was the only conference series which had mechatronics in its title. Searching the internet today reveals a myriad of national and international groups and organisations promoting mechatronics events

As Memiş Acar says in his history of the Mechatronics Forum which appears as the Forward to this book, the word *mechatronics* is generally taken as having being coined in the early 1970s by Tetsuro Mori of the Yaskawa Electric Co. in Japan. Interestingly, from 1972 to 1982, *mechatronics* was a registered trademark of the Yaskawa Electric Co. It was not until the early 1980s that other organisations began to use the term in order to describe the philosophy of design teams.

Long before the word mechatronics came into general use it was recognised in industry that in order to facilitate innovation and increased efficiency in manufacturing and product design, it was vital for engineers and technicians from the disciplines of *mechanics* and *electronics* to work in synergy as teams rather than independently.

In my particular research area of marine systems, it is well known that the pioneering work of both Minorski [1] and Sperry [2] during the first quarter of the 20th century led to the development of automatic steering, or the ship steering autopilot. The evolution of the autopilot was itself made possible by the parallel development of powered rudders, or steering machines, and especially the electrically driven gyrocompass which overcame the problems associated with magnetic compasses which had their readings corrupted by local magnetic fields and the electrical systems in ships. Indeed, the invention of the electrically driven gyrocompass is arguably the most important breakthrough in ship control systems design, and its incorporation into the ship steering autopilot is probably one of the first examples of *mechatronics in action*.

The important legacy of Sperry and Minorski's innovative work and their seminal publications is the three-term or proportional-integral-derivative (PID)

---

<sup>1</sup> Coventry University, UK

controller which continues to be the industry preference and standard for automatic control systems.

Whilst the above focuses on marine systems, it is evident that the mechatronics philosophy encompasses many disciplines and applications, a fact which is not only succinctly reinforced by David Bradley and David W. Russell's introductory chapter to this book, but also by the range of topics presented in the accompanying chapters. John Millbanks's chapter covering the interrelationship of mechatronics and sustainability is a timely reminder that the mechatronics philosophy is more than simply ensuring the initial product design is right; it is equally applicable for whole life/cradle-to-grave considerations. Other important and key applications of *mechatronics in action* which are at the leading edge of technological developments pertain to road, rail and air transportation systems, i.e., fly-by-wire, steer-by-wire, brake-by-wire, tilting trains, aircraft and space vehicles, where embedded microprocessor systems facilitate and augment the necessary interface between electrical and mechanical components and subsystems.

The book also contains two chapters which address mechatronics education, an area that is often popular and well-attended at sessions at the Mechatronics Forum and other conferences. It is pleasing to see that mechatronics courses at pre-degree, degree and post graduate levels offered by universities in Europe, the Far East and America are on the increase, but disappointing that in the United Kingdom, mechatronics courses have not been as popular as would be expected. This is the case despite the UK industry's well-publicised requirements for engineers and technicians who are well-versed in both electrical and mechanical engineering.

A solution to this is for bodies such as the Mechatronics Forum to continue to promote the mechatronics philosophy through its conferences, seminars lectures and books. I therefore commend the authors for producing this extremely informative combination of topics, which taken together, demonstrate the importance of mechatronics and the significant impact that *mechatronics in action* has on our daily lives.

## References

1. Minorski N (1922) Directional stability of automatically steered bodies, J. American Society of Naval Engineers, 34;280–309.
2. Sperry EA (1922) Automatic steering, Trans. Society of Naval Architects and Marine Engineers;61–63.

# Contents

<b>1 Introduction</b> .....	1
<i>David Bradley and David W. Russell</i>	
1.1 Background .....	1
1.2 What Is Mechatronics? .....	1
1.2.1 Mechatronics and Design Innovation .....	4
1.2.2 Mechatronics and Manufacturing .....	5
1.2.3 Mechatronics and Education .....	7
1.3 Mechatronics and a Sustainable Future .....	9
1.3.1 Sustainability .....	9
1.3.2 Mechatronics and Sustainability .....	11
1.4 The Book .....	13
References .....	14
<b>2 Consumption to Contribution: Sustainable Technological Development Through Innovation</b> .....	19
<i>John H. Millbank</i>	
2.1 Introduction .....	19
2.2 The Interpretation of Meaning for Sustainability and Innovation .....	20
2.3 Deconstructing Technological Innovation as a Driving Force for Sustainable Engineered Systems .....	21
2.4 Forecasting, Foresight and Technology Assessment .....	23
2.5 The Influence and Impact of Information and Communication Technologies .....	24
2.6 Consumption, Obsolescence and Moves Towards Future Proofing ....	26
2.7 Complexity Paradigms Within a Sustainability Context .....	28
2.8 Rationalising Material Selection and Processing .....	29
2.9 Conclusion – From Responsible Design to Resource Recovery .....	31
References .....	34
<b>3 The “Revolution”: a Small Company Revived</b> .....	43
<i>David Dawson</i>	
3.1 Some History of the UK Industry-Academic Link, the “KTP” .....	43
3.2 Some Observations on the Acceptance of Computer-aided Engineering (CAE) in Smaller Companies.....	44
3.3 The Ducker Engineering Case Study .....	45
3.3.1 Problem or Opportunity?.....	45

3.3.2	The “Revolution” .....	49
3.3.3	Further Benefits Demonstrated in the CAE Application .....	51
3.4	Conclusions .....	53
	References .....	54
<b>4</b>	<b>A Mechatronic Design Process and Its Application</b> .....	<b>55</b>
	<i>Xiu-Tian Yan and Rémi Zante</i>	
4.1	Introduction to Mechatronic Design .....	55
4.2	Mechatronic Design Process Model .....	55
4.3	A Mechatronic Case Study .....	59
4.3.1	Mechatronic System Design Problem Description .....	59
4.3.2	Design Concept Development .....	59
4.3.3	Detailed Design .....	61
4.3.4	Electronic Control Unit.....	67
4.4	Conclusions .....	69
	References .....	70
<b>5</b>	<b>A Mechatronic Design of a Circular Warp Knitting Machine</b> .....	<b>71</b>
	<i>Memiş Acar</i>	
5.1	Introduction .....	71
5.2	Warp Knitting Cycle.....	72
5.3	Circular Warp Knitting Machine Concept.....	73
5.4	The Needle Reciprocating Mechanism.....	75
5.5	The Patterning Mechanism.....	75
5.5.1	Servo Motor Selection .....	76
5.6	The Prototype .....	78
5.6.1	Servo-controlled Needle Motion .....	79
5.6.2	The Yarn Feed Mechanism.....	80
5.6.3	Truncated-cone Optimisation .....	80
5.7	Conclusions .....	80
	Acknowledgements.....	81
	References .....	81
<b>6</b>	<b>Mechatronics and the Motor Car</b> .....	<b>83</b>
	<i>Derek Seward</i>	
6.1	Background.....	83
6.1.1	Vehicle Mechatronic Systems .....	83
6.1.2	Drivers for Change .....	86
6.2	Engine Basics .....	88
6.3	The Mechanical Solution for Ignition Timing and Fuel Delivery .....	89
6.3.1	Traditional Mechanical Ignition Timing.....	89
6.3.2	Fuel Delivery – the Carburettor .....	90
6.4	The Mechatronic Solution to Engine Management .....	92
6.4.1	Sensors.....	92

6.4.2	Actuators .....	93
6.4.3	Processing.....	94
6.5	Anti-lock Braking System (ABS).....	97
6.5.1	Background to the Theory of Braking .....	97
6.5.2	ABS Components .....	99
6.5.3	ABS Diagnostics .....	101
6.6	Conclusions .....	101
	References .....	101
<b>7</b>	<b>Multi-mode Operations Marine Robotic Vehicle – a Mechatronics Case Study</b> .....	<b>103</b>
	<i>Daniel Toal, Edin Omerdic, James Riordan and Sean Nolan</i>	
7.1	Introduction .....	104
7.2	MPPT Ring System Overview .....	105
7.2.1	Main Features .....	105
7.2.2	The Virtual Underwater Laboratory .....	107
7.2.3	Architecture and Implementation .....	108
7.2.4	Imaging Sonar Simulator.....	110
7.2.5	Laboratory Configuration.....	111
7.3	University of Limerick (UL) Thrusted Pontoon/ROV .....	112
7.3.1	Base Vehicle.....	112
7.3.2	High-resolution Imaging Tool Skid.....	114
7.3.3	Onboard Electronics and Computer Control .....	114
7.3.4	Fault Tolerant Thruster Control.....	115
7.3.5	Autotuning of Low-level Controllers .....	116
7.3.6	High Frequency Sonar Enabling at Seabed Operation .....	117
7.3.7	Interchangeable Inshore and Deep Water Winch System.....	118
7.4	System Testing .....	118
7.5	Conclusions .....	118
	References .....	119
<b>8</b>	<b>Wireless Communication Technology for Modular Mechatronic Controllers</b> .....	<b>121</b>
	<i>Glen Bright, Nkgatho S. Tlale and Christopher M. Kumile</i>	
8.1	Introduction .....	121
8.2	Modular Mechatronic Controllers .....	122
8.3	Communications Technology.....	124
8.4	Model-based Mechatronic Controllers .....	125
8.5	Wireless Mechatronic Controller for the Camera Platform.....	128
8.5.1	Requirements for the Wireless Mechatronic Controller .....	129
8.6	Modelling of the Camera Platform.....	130
8.7	Results .....	132
8.7.1	Performance of the System.....	133
8.8	Conclusions .....	134
	References .....	134

<b>9 The Utility Function Method for Behaviour Selection in Autonomous Robots .....</b>	<b>135</b>
<i>Mattias Wahde</i>	
9.1 Introduction .....	135
9.2 Behaviour Selection.....	136
9.3 The Concept of Utility .....	137
9.3.1 A Biological Example .....	139
9.4 The Utility Function Method.....	141
9.4.1 Motivation .....	141
9.4.2 Method.....	141
9.4.3 Optimisation Procedure .....	146
9.4.4 Application Example – a Transportation Task .....	151
9.5 Ongoing Work .....	154
9.5.1 Extended UF Method.....	154
9.5.2 Data Preprocessing and Artificial Emotions.....	154
References .....	155
<b>10 Force Sensing in Medical Robotics.....</b>	<b>157</b>
<i>Kaspar Althoefer, Hongbin Liu, Pinyo Puangmali, Dinusha Zbyszewski, David Noonan and Lakmal D Seneviratne</i>	
10.1 Background.....	157
10.2 Force Sensing Techniques in Medical Robotics.....	159
10.3 The Use of Force Sensing in Medical Robotics.....	163
10.3.1 Haptic Feedback During Robotic Surgery .....	163
10.3.2 Soft Tissue Diagnosis Through Tissue Mechanical Property Identification .....	164
References .....	171
<b>11 Intelligent Prostheses – a Biomechatronics Approach.....</b>	<b>173</b>
<i>Abbas Dehghani</i>	
11.1 Introduction .....	173
11.2 Biomechatronics and Biological Systems.....	174
11.2.1 Biomechatronics .....	174
11.2.2 The Human Body.....	175
11.3 Prosthetics .....	175
11.3.1 Human Locomotion .....	177
11.3.2 Current Prosthetics .....	179
11.3.3 Future Prosthetics .....	191
11.4 Conclusions .....	193
References .....	193



<b>12 Education in Mechatronics</b> .....	197
<i>Vladimir V. Vantsevich</i>	
12.1 Introduction and Background .....	197
12.2 The Development of the Master of Science in Mechatronics Systems Engineering at Lawrence Technological University .....	203
12.2.1 Rational for Course Development .....	203
12.2.2 Programme Structure and Implementation .....	206
12.3 Summary .....	216
References .....	217
<b>13 Mechatronics Education</b> .....	219
<i>Job van Amerongen</i>	
13.1 Introduction .....	219
13.2 Historical Context.....	220
13.3 Curriculum .....	222
13.3.1 Mechatronic Designer Programme .....	223
13.3.2 BSc Curriculum .....	224
13.3.3 MSc Curriculum .....	228
13.4 Modelling of Mechatronic Systems.....	229
13.4 Conclusions .....	231
References .....	232
<b>14 A Personal View of the Early Days of Mechatronics in Relation to Aerospace</b> .....	235
<i>Bill Scarfe</i>	
<b>15 Mechatronic Futures</b> .....	241
<i>David Russell and David Bradley</i>	
15.1 Introduction .....	241
15.2 Challenges .....	242
15.3 Home Based Technologies .....	243
15.4 Medicine and eHealth.....	244
15.5 Transportation .....	245
15.6 Manufacturing, Automation and Robotics .....	246
15.7 Communications.....	247
15.8 Nanotechnologies .....	247
15.9 Advanced Algorithms.....	248
15.10 Artificial Intelligence .....	248
15.11 Conclusions .....	249
References .....	249
<b>Authors</b> .....	251

# Chapter 1

## Introduction

David Bradley<sup>1</sup> and David W. Russell<sup>2</sup>

### 1.1 Background

Since 1989, the Mechatronic Forum conferences have provided practitioners and educators working in the field of mechatronics with the opportunity to meet and discuss not only technical developments, but also aspects of course design and delivery. As mechatronics has developed as a subject, and as more and more students are exposed to the underlying concepts through courses at undergraduate and master's levels [1–3], there is an increasing requirement to provide both students and practitioners with access to examples of functioning systems in order to reinforce the concepts and structures which underpin the mechatronic concept.

This book essentially arose from discussions at the Mechatronics Forum conferences, and in particular at Penn State Great Valley in 2006 where the education workshops made it clear that despite the growth in the number and availability of mechatronic textbooks, there was a need for something which drew attention to issues associated with and impacting on the design and implementation of mechatronic systems rather than the underlying technologies.

The aim of the book is therefore to provide, through the medium of case studies by leading practitioners in the field, an insight for all interested in the mechatronic concept and the ways in which mechatronic systems and the associated educational programmes are designed, developed and implemented [4–7].

### 1.2 What Is Mechatronics?

As a discipline, mechatronics is faced with the problem that though it has the evolutionary path suggested by Figure 1.1, it does not represent a single technological domain, but rather the integration of a number of such domains at

---

<sup>1</sup> University of Abertay Dundee, UK

<sup>2</sup> Penn State Great Valley, USA

the systems level. This means that there is no single, clear and agreed upon definition of mechatronics around which practitioners and educators can align themselves and develop courses and programmes. Indeed, as John Millbank, one of the contributing authors has commented [8]:

By definition then, mechatronics is not a subject, science or technology *per se* – it is instead to be regarded as a philosophy – a fundamental way of looking at and doing things, and by its very nature requires a unified approach to its delivery.

This perspective is illustrated in part by Figure 1.2 which places mechatronics at the centre of a network of engineering functions ranging from aesthetics to marketing. In reviewing this network it is, however, important to recognise and understand that mechatronics is not solely about technology but relies on people, and in particular on the interaction between individuals to make it work.

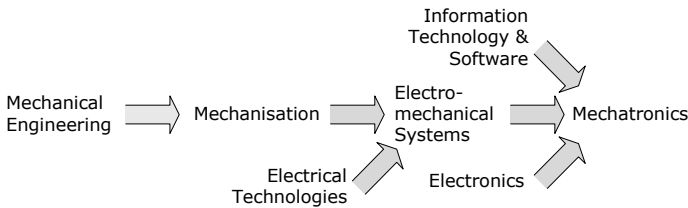

**Fig. 1.1** The evolution of mechatronics [9–12]

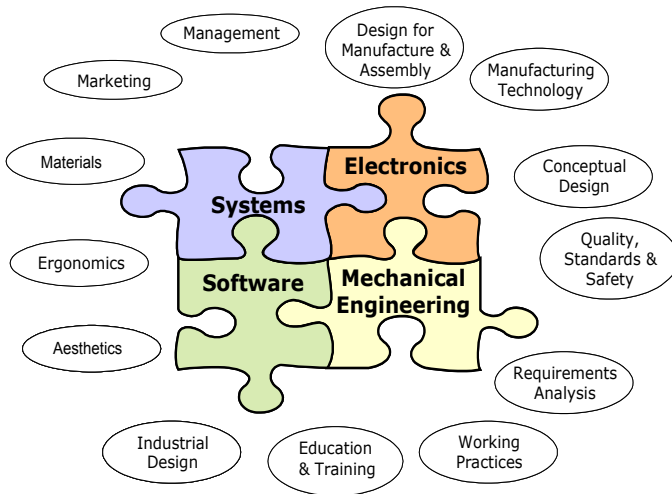

**Fig. 1.2** Mechatronics and some of its related domains

Mechatronics can therefore be considered as being, in essence, a systems approach to the design, development and implementation of complex engineering systems which takes as its foundation the transfer of functionality from the physical domain to the information domain. The strength of the approach is that it supports the understanding of the nature of the embedded complexity by ensuring that the different engineering and other disciplines are considered together from the start of the design process. A mechatronic approach to system design and development therefore has much in common with the Concurrent Engineering model of Figure 1.3 in that it emphasises parallelism and implies an integrated path from concept to implementation in which there is a balance between all activities within the design process.

This parallelism is important as new products traditionally generate the most revenue early in their life cycles, particularly if the products offer new features not present in their competitor's products. As the product matures and competitors enter the market, profit erosion will begin to occur as the competition for available customers increases. It is therefore important that products are designed and produced on time, and that production rates are rapidly ramped up to mature levels. Any delays in the release of the product to the market will translate into lost sales that will not be recovered over the life of the product.

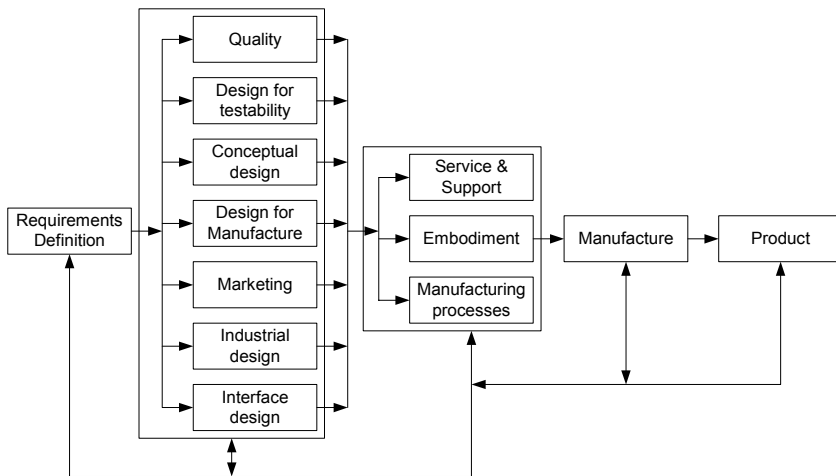

**Fig. 1.3** Concurrent engineering work flow

As indicated by Figure 1.4 [13, 14], a key element of this profile is the need to convince the pragmatists that the system is of value to them once the innovators and early adopters have opened up the market. The introduction of a mechatronic approach to technology integration allied to a concurrent engineering development strategy has resulted in products which are inherently more capable, and hence more attractive to users than their predecessors at reducing real costs.

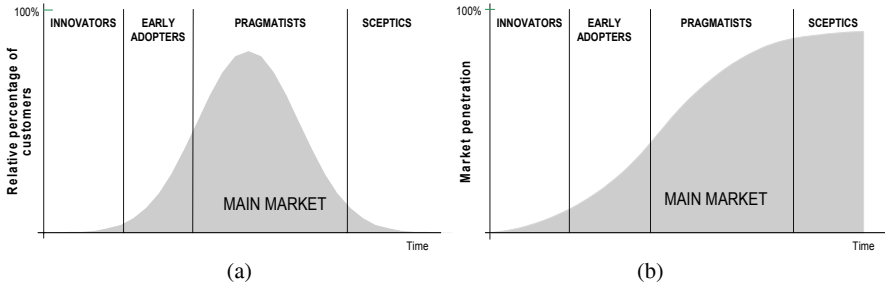

**Fig. 1.4** Profiles of technology adoption and market penetration: (a) adoption, and (b) market penetration

### 1.2.1 Mechatronics and Design Innovation

In recent years, products and systems of all types from domestic appliances to vehicles have become increasingly complex. This complexity is in turn defined by the combination of local and distributed processing power with mechanical design, and is driven by the increased availability of such processing power allied to enhanced communications strategies and protocols. Thus, at one level a system such as the Wii games console [15] utilises three-axis accelerometers to record motion and to translate that motion into an on-screen response by means of a Bluetooth [16] communications link. At another level, a modern car will integrate multiple systems ranging from engine management to environmental controls for driver and passenger comfort, and potentially even autonomous navigation [17].

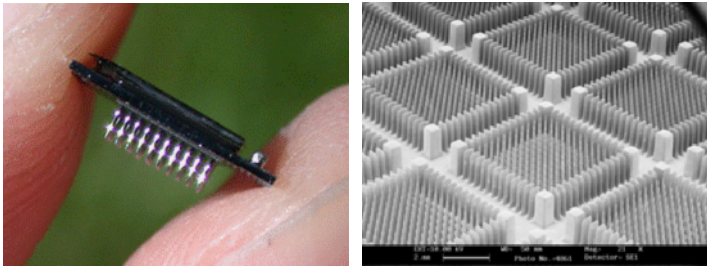

**Fig. 1.5** University of Utah *Integrated Neural Interface* chip<sup>3</sup>

These developments are supported by the increasing availability of ‘smart components’ such as the SunSPOT<sup>4</sup> system from Sun Microsystems [18], which in turn facilitate the construction of larger systems utilising the embedded processing power of their distributed elements. The increasing availability of system elements

<sup>3</sup> Courtesy of the University of Utah

<sup>4</sup> Sun Small Programmable Object Technology

such as SunSPOTs and RFID tags is resulting in increasingly complex systems in which the ability to analyse and interpret the data then becomes the major source of added value.

While mechatronics has been historically associated with system products such as vehicles and manufacturing technologies such as robots, these same mechatronic concepts are now appearing in applications such as healthcare. Considering this latter area in more detail, developments in prosthetics are resulting in artificial limbs of increasing capability. These ultimately have the potential to be linked to a neural interface such as that of Figure 1.5 [19], making them capable of decoding nerve impulses and returning a feedback signal to the user to achieve more realistic control than is currently possible.

In physiotherapy, the development of systems such as MANUS [20, 21], Locomat [22] and NeXOS [23] aim to support physiotherapists working with a wide range of individuals and conditions. At the systems level, the development of telecare systems based on a distributed network of sensors to monitor individual behaviour within their home environment to support independent living is attracting increasing interest, particularly when combined with advanced analysis techniques to interpret such behaviour [24, 25].

### ***1.2.2 Mechatronics and Manufacturing***

Engineers from most disciplines will quite understandably associate mechatronics with robotics and factory systems. Systems that move, machine and assemble “hard” substances are really only classifiable as ‘mechatronic’ to the degree that they contain elements of reasoning and agility. A flipper paddle on a production line barely counts as a robot! As manufacturing systems have evolved across the world despite the plentiful labour supply, the inclusion of virtually unattended automation components is growing. Areas of mechatronic involvement in manufacturing include assembly, machining, inspection, dangerous material handling and disassembly.

The modern automobile contains many of the same technologies, including all-wheel drive and electronically-actuated fuel injection. Since the inception of the production line illustrated in Figure 1.6 [26, 27], automobile assembly plants have led the way in robotic painting, welding and heavy material handling.

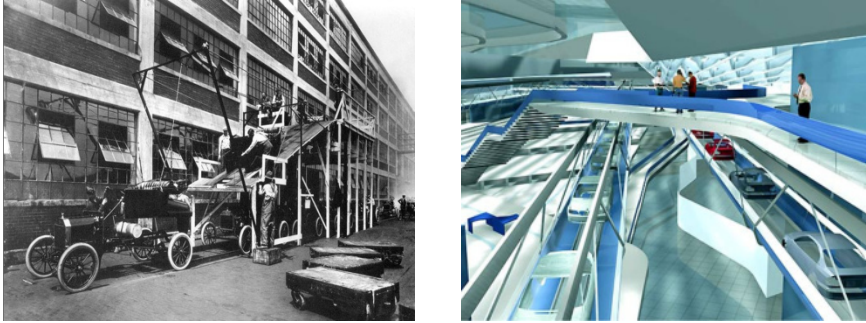

**Fig. 1.6** The evolution of automotive assembly lines

With the introduction of the ‘make to order’ paradigm, manufacturing is now far more sophisticated than simply mass producing items for inventory. Buyers now want to customise everything and to do so at almost the unit level. This has necessitated an agility of operations that was previously unimagined. Manufacturing groups can now be created [28] ‘on-the-fly’ in response to job specifications, which may involve autonomous work-cells moving into varying positions as part of a dynamic collaboration. In addition to containing many degrees of freedom, each manufacturing cell may also be multi-faceted and provide a variety of job functions on a piece by piece basis. For example, a unit that is customarily used as a gripper to move completed work-pieces from assembly to a conveyor may also from time to time insert a component, and all within the same production run.

Because of the combinational complexity of such systems, the scheduling of flexible architecture work groups has attracted the interest of methodologies that include game theory [29] and self-organisation [30, 31]. The problems associated with flexible groupings are manifold. Any operation that involves autonomous vehicular movement must allow for unobtrusive inactive parking, dynamic path and scene analysis, unit return and recovery strategy, and self reporting of malfunctions and maintenance intervals. All of these are commonplace mechatronic system issues.

The pharmaceutical and power generation industries are also heavily dependent on mechatronic devices to provide skilled operations in environments where it is either unsafe or inconvenient for humans to work. This includes the handling of toxic and radioactive materials and maintenance in heavily polluted atmospheric conditions. Automated inspection systems provide 100% quality control and dramatically outperform humans in such boring and repetitive tasks.

While mechatronic systems are an obvious area of interesting research, they are also gaining acceptance and popularity in manufacturing processes and are becoming an integral part of a greener and more sustainable industrial world. Along these lines, there is a current trend to design commodity items such as cell phones for disassembly and component reuse. Manufacturers are usually concerned with securely fastening units together, which consequently makes for

safer use but condemns the product to the landfill. By careful design for remanufacturing, it will become economically feasible as well as environmentally prudent to produce goods that are truly recyclable with no loss in quality. Mechatronics will feature heavily in this arena!

### 1.2.3 Mechatronics and Education

In the development of mechatronics education, the concern in course design has always been that of achieving an appropriate balance between providing the necessary depth of understanding of core technologies and the ability to develop solutions which integrate those technologies. This may be compared with a subject based approach to engineering education where the emphasis is on ensuring a depth of understanding within the subject area.

The education of a mechatronics engineer thus has to place a greater emphasis on the ability to work across and between individual areas of technology. This is not, however, to suggest that a mechatronics engineer does not have to have a depth of knowledge in certain specialist areas, rather that such depth is balanced by an understanding and appreciation of the contributions of other areas of technology as is suggested by Figure 1.7.

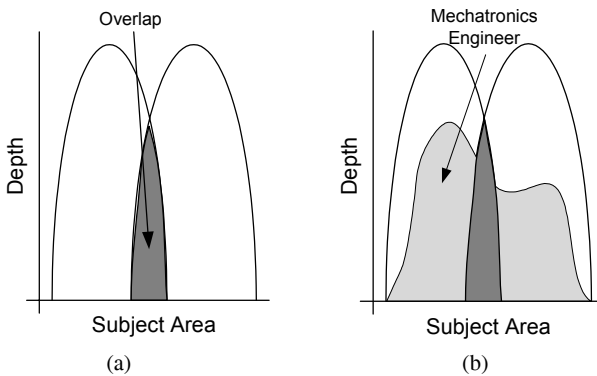

**Fig. 1.7** Balance of technical expertise for specialist and mechatronics educated engineers: (a) specialist education, and (b) mechatronics education

The achievement of a balanced programme of mechatronics education must therefore ensure that individuals are provided with sufficient depth in at least one area of technology in order to allow them to make an effective contribution to that area, whilst ensuring the breadth of understanding necessary to give them credibility in regard to other subject specialists. The key challenge then facing mechatronics course designers is that of ensuring that there is an appropriate balance between depth and breadth within the course, as well as providing opportunities to enable students to practice integration.



Though mechatronics emphasises integration, it may also be perceived as encompassing a number of themes such as design, manufacturing or automation. In relation to course development, the choice of theme is generally dictated by a number of factors including:

- the backgrounds and interests of the staff involved in teaching;
- industrial requirements, both locally and nationally;
- student perceptions and interests;
- availability of resources, particularly human and financial;
- research activity.

While it is unlikely that any one of these considerations will dominate course development to the exclusion of others, any one of these factors may well be the defining influence for a particular programme or course. Generally, however, they will all play some role in determining the structure of any course.

For instance, resource implications will often mean that teaching of specialist material will require that mechatronic engineers are incorporated as part of a larger group of subject specialists for this purpose, with the courses then being structured to meet the needs of the subject specialists rather than the mechatronics students. Also, the increasing modularisation of programmes can tend to mitigate against the ability to introduce the necessary integrating material, particularly where modules are seen as having to be complete and entire within themselves.

In light of the above challenges, how might the designers of a mechatronics course respond? What is clear is that they are faced with a number of questions including:

- Should a theme be chosen or should it emerge as a result of the local expertise and enthusiasms?
- How are the integration aspects of mechatronics to be introduced and managed?
- How are external requirements, as for instance the Bologna Agreement in Europe [32, 33], to be managed?
- What is the local market for graduates, and is the proposed course going to meet those requirements?

Mechatronics has always suffered to some degree from an identity crisis both within the academic community and elsewhere, and indeed this is likely to continue to be the case given the diversity of approaches and emphasis that are found within the community. At the same time, there is a need for graduate engineers with the particular integration skills that are provided by a mechatronics education. The challenge facing mechatronics course designers is therefore that of achieving an effective balance between the requirements for detailed knowledge and engendering of the ability to act in an integrating role in a wide range of engineering environments.

The achievement of this balance is itself subject to a whole range of pressures ranging from the rapid advance of technology to external factors impacting on

course management and design such as the moves to implement sustainable systems or increase student mobility. The underlying precepts presented here will, however, remain as a constant for course designers and developers.

### 1.3 Mechatronics and a Sustainable Future

It is clear that the future development of mechatronics will need to be integrated with the need to meet and respond to a range of challenges in areas including energy systems, transport, health care, medicine and manufacturing. Indeed, it can be argued that the achievement of sustainable systems in these and other areas will depend on the ability to integrate a mechatronic approach to system design and development into corresponding developments in areas such as materials technology. This will impact not only on specific products, but on the ways they are made.

This will in turn cause present considerations of design for manufacture and assembly which are often in conflict with the requirements of design for disassembly or maintenance to be brought into question. Consider, for instance, the use of snap assembly methods for joining components. These are easy to assemble but can make access problematic without the destruction of the item in question.

#### 1.3.1 Sustainability

In the 1987 report of the Brundtland Commission, *Our Common Future*, sustainable development was defined as [34]:

Development that meets the needs of the present without compromising the ability of future generations to meet their own needs.<sup>5</sup>

In the UK, the Department of Trade and Industry has stated that [35]:

Sustainable development is about achieving economic growth, environmental protection and social progress at the same time.

The paper *A Way with Waste* from the Department of the Environment, Food and Rural Affairs (DEFRA) states that [36]:

Sustainable waste management means using material resources efficiently to cut down on the amount of waste we produce. And where waste is produced, dealing with it in a way that actively contributes to the economic, social and environmental goals of sustainable development.

---

<sup>5</sup> Formerly the World Commission on Environment and Development and chaired by the then Prime Minister of Norway, Gro Harlem Brundtland

There is increasing recognition of the importance of environmental sustainability to industry, as reflected in a number of indices that have been developed to try to express levels of sustainability in product development. This is reflected in legislation which seeks to control the environmental impact of products through the regulation and control of their disposal and the management of the associated waste materials.

Within the EU, some of these key legislative elements introduced, or in the process of being introduced are [37]:

- waste from electrical and electronic equipment [38];
- restriction of the use of certain hazardous substances in electrical and electronic equipment [39];
- end of life vehicles [40];
- packaging and packaging waste [41].

Other legislation seeks to control the production of pollutants such as greenhouse gases, as for instance the EU Emissions Trading Scheme which came into being on January 1, 2005 [42, 43]. This brings about the possibility of trading in ‘pollution certificates’, such as the *Clean Development Method* certification under the auspices of the United Nations *Framework Convention on Climate Change* (UNFCCC) [44–46].

All of the above lead to an increasing recognition that there is a requirement to adopt a more holistic approach to the design and use of a wide range of products and systems, and that whole life considerations need to be taken into account as part of the design process [47–49]. This has led to the concept of Life Cycle Assessment and the ISO 14040 [50] series of standards which sets out 4 key elements for consideration, namely:

- goal and scope definition;
- impact assessment;
- inventory of extractions & emissions;
- interpretation.

Despite the considerations above, however, it cannot be said that environmentally friendly strategies and approaches to whole life cycle design have been widely adopted. Indeed, in his keynote address to the ICED03 conference, Dr Tim McAlloone of the Technical University of Denmark commented that:

There are now a number of centres of excellence in EcoDesign practice, both in industry and academia, where tools and methods have crystallised into positive changes to the environmental performance of the product under development. However, there are even more instances where the tools and methods developed fail to be integrated into real life product development, due to shortcomings of either academia or industry whilst developing the tools, or when attempting their integration.

There is indeed a range of activity worldwide with subjects under investigation including [51–55]:

- environmental sustainability;
- EcoDesign;
- EcoDesign tools;
- design for sustainability;
- environmental technology;
- lifecycle assessment;
- environmentally conscious manufacturing;
- environmentally friendly product design;
- environmentally friendly products.

Industry has taken the lead in some of these areas as for instance in the work undertaken in Germany by the Verein der Automobilindustrie [56] (VDA) and through the *Blue Angel* programme [57]. In Italy, Fiat instituted the *FARE* (Fiat Auto Recycling) programme [58] in 1992, which by 1997 had 251 recycling centres while in Sweden. Volvo has developed their EPI (Environmental Product Information) system [59] as a means of informing users as to the environmental impact of their cars. Similar strategies have been followed by many other car manufacturers. In other areas, companies such as Dell [60] and HP [61] have instituted major environmental management programmes in association with their product range.

There have also been attempts to develop tools to support environmentally friendly design, the best known of which is probably that of Boothroyd & Dewhurst that uses the MET (Materials, Energy, Toxicity) points system developed by TNO in Holland [62].

### ***1.3.2 Mechatronics and Sustainability***

As suggested, mechatronics should have a considerable role in achieving sustainable products and systems. Some of the potential areas where mechatronics is likely to have a major impact are outlined below and some will be considered in more detail in subsequent chapters.

#### *Design*

In relation to developments mechatronics and the design process, approaches such as EcoDesign<sup>6</sup> encompass a wide range of issues which will impact upon the general mechatronic concept, particularly the means of achieving sustainable outcomes in ways which support trade-offs between system elements. Thus, the adoption of a manufacturing process which has associated with it slightly increased levels of waste may support actions elsewhere in the product lifecycle which lead to an overall reduction in waste production.

---

<sup>6</sup> Also Green Design, Sustainable Design and Environmentally Friendly Design, etc.

### *Transport*

This is likely to be an area where mechatronics will significantly influence design, development and operation. For instance:

*Rail* – The further development of tilting trains, active suspensions, driven and steered wheelsets and traction and braking control are all likely to feature to some degree in future train systems, along with enhanced drive technologies and controller strategies [63]. Other potential areas of development include high-speed trains and the use of maglev technologies [64, 65].

*Road Transport* – The move towards hybrid vehicles and the use of fuel cell technology [66, 67] as well as on-board systems for driver assistance and management support a wide range of potential developments. Developments at the vehicle level would then be supplemented and supported by enhanced traffic management and routing systems that would look at route loading and capacity to optimise journey times and minimise pollution.

*Aircraft* – Aircraft, the growth of air transport and the impact on the environment is undoubtedly one of the most contentious areas in which mechatronics is likely to play a role. Issues include the design of aircraft that are quieter, more fuel efficient and have a lower environmental impact than those currently in use [68–71].

This shift is seen with the introduction of the Airbus A380 and the Boeing 787 Dreamliner. More radical developments and concepts include the ‘blended wing’ [72, 73] and enhanced engine technologies.

### *Energy Technologies*

The deployment and use of alternative energy sources such as wind and wave power [74, 75], the introduction into the home of micro combined heat and power (microCHP) systems [76], heat pumps [77] and fuel cells as well as new generations of appliances and energy management options within the home will all be influenced by mechatronic approaches to their design, operation and control.

### *Manufacturing*

Mechatronics will continue to support the development of advanced manufacturing systems involving autonomously reconfigurable machine tools [78] and dynamic decision making [79] as an integral part of the process. Such developments will in turn support the implementation of production facilities that are more energy efficient and have lower environmental impact than those currently in use.

### *Health*

This is an area where mechatronics might be expected to have a major impact. Specific instances include the development of enhanced and intelligent prostheses for both the upper and lower limbs [80–82], the introduction of systems to support the rehabilitation of a range of conditions [83, 84], the provision of new surgical methods and techniques involving the deployment of robotic systems and telecare, telemedicine and telehealth strategies based around enhanced sensors, networking and data analysis [85]. In each of these and related areas, the deployment of a mechatronic approach is likely to be key in achieving robust, reliable and effective systems.

### *Materials*

The choice of materials is becoming increasingly important in relation to the design and operation of systems of all types, as for instance in the increased use of composite materials in vehicles such as cars and aircraft as well as in consumer products. The provision of new types of materials has itself made it possible to develop these products in a way which supports the general mechatronic concepts of integration at the systems level [86–88].

### *Economics, Standards and Legislation*

Issues such as those raised by the Kyoto Protocol and the subsequent Bali Action Plan [89, 90], and in the UK by the Stern Report [91] as well as legislation coming out of Europe and elsewhere and including topics such as carbon trading will all have an impact on the way in which mechatronic systems are designed and implemented.

## **1.4 The Book**

As indicated, the aim of the book is to provide mechatronics practitioners and students with added insight into the way in which mechatronic systems have evolved and developed through the medium of case studies. These studies encompass a range of approaches to and views on mechatronics covering the design process and sustainability, the need to involve the system users in the process of implementation, the importance of the interface, machine intelligence, manufacturing technology, robotics, medical applications and course design. Each case study is written by an individual or group of individuals who have been involved with mechatronic systems for a number of years. In many cases, this involvement has been at a number of levels incorporating research, implementation and course design. The book therefore provides a unique insight into the world of the mechatronic engineer and supports the wider understanding

of the subject as an approach to the design, development and implementation of complex systems.

Following the introduction of Chapter 1, Chapter 2 considers the question of sustainability and how the issues arising in this area are likely to impact the design and implementation of future mechatronic systems. Chapter 3 then provides an example of how CAD tools can be used to support ‘3D-thinking’ in relation to the design and implementation of mechatronic systems. Chapters 4 and 5 then provide specific examples as to how the mechatronics approach can be and has been applied to different industrial systems.

Chapter 6 looks at the impact that mechatronics has had and, still is having on the design and operation of motor vehicles, and shows how mechatronic systems and sub-systems are increasingly being integrated at all levels within vehicles. Chapter 7 looks at the application of mechatronics to sub-sea vehicles, the requirements for operating in harsh environments and the use of virtual environments in design, simulation and testing.

Chapter 8 examines how a mechatronics approach can be used to support the development and implementation of a remotely operated system, whilst Chapter 9 considers the deployment of machine intelligence and its implementation in a particular context. Chapters 10 and 11 consider the growing role of mechatronics in medicine and healthcare by looking at applications in surgery and prosthetic design.

Chapters 12 and 13 consider the development of mechatronics education programmes and the design of such programmes. Chapter 14 provides a retrospective view of the early development of mechatronics within the aerospace industry and the challenges to its adoption.

The book then concludes with Chapter 15, which attempts to provide an outlook that identifies and establishes the future challenges that mechatronics will be required to meet.

## References

1. Bradley D (2004) What is Mechatronics and Why Teach it? *Intl. J. Electrical Engineering Education*, **41**(4):275–291
2. Bradley D (1997) The What, Why and How of Mechatronics. *IEE J. Science & Education*, **6**(2):81–88
3. Bradley D (2000) Mechatronics – An established discipline or a concept in need of direction? *Mechatronics2000*, Atlanta, CDROM
4. Habib MK (2008) Interdisciplinary Mechatronics engineering and science: problem-solving, creative-thinking and concurrent design synergy, *Int. J. of Mechatronics and Manufacturing Systems*, **1**(1):4–22
5. Craig K (2001) Is anything really new in mechatronics education?, *IEEE Robotics & Automation Magazine*, **8**(2):12–19
6. Siegwart R (2001) Grasping the interdisciplinarity of mechatronics, *IEEE Robotics & Automation Magazine*, **8**(2):27–34

7. Doppelt Y (2005) Assessment of Project-Based Learning in a Mechatronics Context, *J. Technology Education*, **16**(2) ([scholar.lib.vt.edu/ejournals/JTE/v16n2/doppelt.html](http://scholar.lib.vt.edu/ejournals/JTE/v16n2/doppelt.html))
8. Millbank J (1993) Mecha-what?, *Mechatronics Forum Newsletter*, Summer
9. Tomizuka M (2002) Mechatronics: from the 20th to 21st century, *Control Engineering Practice*, **10**(8):877–886
10. Harashima F, Tomizuka M, Fukuda T (1996) Mechatronics—what is it, why, and how? *IEEE/ASME Transactions on Mechatronics*, **1**:1–4
11. Kyura N, Oho H (1996) Mechatronics—an industrial perspective, *IEEE/ASME Transactions on Mechatronics* **1**:10–15
12. Brown A, 2008, Who owns Mechatronics, *Mechanical Engineering*, American Society of Mechanical Engineers, June ([www.memagazine.org/contents/current/features/whoowns/whoowns.html](http://www.memagazine.org/contents/current/features/whoowns/whoowns.html))
13. Moore G (1991) *Crossing the chasm: marketing and selling high-tech products to mainstream customers*. HarperCollins, New York
14. Rogers E (1995) *Diffusion of Innovation*. 4th edn, The Free Press
15. Marshall D, Ward T, McLoone S (2006) From chasing dots to reading minds: the past, present, and future of video game interaction. *Crossroads* **13** (2):10
16. [www.bluetooth.com](http://www.bluetooth.com)
17. Thrun S *et al.* (2006) Stanley: The Robot that won the DARPA Grand Challenge, In: Buehler M, Iagnemma K, Singh S (eds) *The 2005 DARPA Grand Challenge*, Springer
18. [www.sunspotworld.com](http://www.sunspotworld.com)
19. [www.inip.utah.edu/index.php?page=index](http://www.inip.utah.edu/index.php?page=index)
20. Krebs HI, Hogan N, Volpe BT, Aisen ML, Edelstein L, Diels C (1999) Overview of clinical trials with MIT-MANUS: a robot-aided neuro-rehabilitation facility. *Technology and Health Care*, **7**(6):419–423
21. Volpe BT, Krebs HI, Hogan N (2001) Is robot-aided sensorimotor training in stroke rehabilitation a realistic option?. *Current Opinion in Neurology*. 14:745–752
22. Lokomat System, Hokoma Medical Engineering Company, [www.hocoma.ch/](http://www.hocoma.ch/)
23. Bradley DA, Acosta-Marquez C, Hawley M, Brownsell S, Enderby P, Mawson S (2009) NeXOS – The design, development and evaluation of a rehabilitation system for the lower limbs, *Mechatronics*, **19**:247–257
24. Bradley DA, Williams G, Brownsell SJ, Levy (2002) Community Alarms to Telecare – The need for a systems strategy for integrated telehealth provision, *Technology and Disability*, **14**(2):63 – 74
25. Glascock AP, Kutzik DM (2006) The Impact of Behavioral Monitoring Technology on the Provision of Health Care in the Home, *J. Universal Computer Science*, **12**(1):59–79
26. [en.wikipedia.org/wiki/Image:A-line1913.jpg](http://en.wikipedia.org/wiki/Image:A-line1913.jpg)
27. [www.designbuild-network.com/projects/bmw/bmw3.html](http://www.designbuild-network.com/projects/bmw/bmw3.html)
28. Katz R (2007) Design Principles in Reconfigurable Machines. *Int. J. of Adv. Manufacturing Tech* **34**: 430–439.
29. Qiu R, McDonnell P, Joshi S, Russell DW (2005) A Heuristic Game Theoretic Approach to Resource Sharing in Reconfigurable Manufacturing. *Int. J. of Adv. Manufacturing Tech* **25**(1-2): 78–87
30. Rao A, Gu P (1994) Expert self-organizing neural network for the design of cellular manufacturing systems. *J. of Manufacturing Systems* **13**(5):346–359.
31. Kubota N, Fukoda T (1999) Structured intelligence for self-organizing manufacturing systems. *J. Intelligent Manufacturing* **10**(2):121–133
32. [www.eua.be:8080/eua/en/policy\\_bologna.jsp](http://www.eua.be:8080/eua/en/policy_bologna.jsp)
33. [www.engc.org.uk/international/bologna.asp](http://www.engc.org.uk/international/bologna.asp)
34. [www.anped.org/media/brundtland-pdf.pdf](http://www.anped.org/media/brundtland-pdf.pdf)
35. [www.dti.gov.uk/sustainability/sus/index.htm](http://www.dti.gov.uk/sustainability/sus/index.htm)
36. [www.defra.gov.uk/environment/waste/strategy/part1/1.htm#why](http://www.defra.gov.uk/environment/waste/strategy/part1/1.htm#why)
37. [europa.eu.int/pol/env/index\\_en.htm](http://europa.eu.int/pol/env/index_en.htm)



38. EU directive 2002/96/EC on waste electrical and electronic equipment (WEEE), Official J. of the European Union, 13 Feb 2003
39. EU directive 2002/95/EC on the restriction of the use of certain hazardous substances in electrical and electronic equipment, Official J. of the European Union, 13 Feb 2003
40. EU directive 2000/53/EC on end-of-life vehicles, Official J. of the European Union, 21 Oct 2000
41. EU directive 94/62/EC on packaging and packaging waste, Official J. of the European Union, 31 Dec 1994
42. EU directive 2003/87/EC on establishing a scheme for greenhouse gas emission allowance trading within the Community, Official J. of the European Union, 25 Oct 2003
43. [www.defra.gov.uk/news/latest/2004/climate-1027.htm](http://www.defra.gov.uk/news/latest/2004/climate-1027.htm)
44. CO2e.com
45. [ageco.tamu.edu/faculty/woodward/ET.htm](http://ageco.tamu.edu/faculty/woodward/ET.htm)
46. [cdm.unfccc.int/](http://cdm.unfccc.int/)
47. Rosemann B (2003) Hidden patterns of innovative environmental designed products. ICED03, Stockholm, pp 197–198
48. Tanskanen P, Takala R (2003) Engineering paradigms for sustainable design of mobile terminals. ICED03, Stockholm, pp 199–200
49. Nuij R (2001) Eco-innovation: Helped or hindered by Integrated Product Policy J. Sustainable Product Design 1(1):49–51
50. [www.iso-14001.org.uk/iso-14040.htm](http://www.iso-14001.org.uk/iso-14040.htm)
51. Global System for Sustainable Development, MIT, [gssd.mit.edu/GSSD/gssden.nsf](http://gssd.mit.edu/GSSD/gssden.nsf)
52. [www.shu.ac.uk/r2u](http://www.shu.ac.uk/r2u)
53. [www.io.tudelft.nl/research/dfs/research/researchset.html](http://www.io.tudelft.nl/research/dfs/research/researchset.html)
54. [www.iabg.de/presse/aktuelles/mitteilungen/200409\\_V-Model\\_XT\\_en.php](http://www.iabg.de/presse/aktuelles/mitteilungen/200409_V-Model_XT_en.php)
55. [www.defra.gov.uk/environment/waste/strategy/part1/1.htm#why](http://www.defra.gov.uk/environment/waste/strategy/part1/1.htm#why)
56. [www.vda.de/index\\_en.html](http://www.vda.de/index_en.html)
57. [www.blauer-engel.de/englisch/navigation/body\\_blauer\\_engel.htm](http://www.blauer-engel.de/englisch/navigation/body_blauer_engel.htm)
58. [www.uneptie.org/energy/act/tp/amf/documents/Fiat.pdf](http://www.uneptie.org/energy/act/tp/amf/documents/Fiat.pdf)
59. [www.volvocars.com/AboutVolvo/EPI/Europe/](http://www.volvocars.com/AboutVolvo/EPI/Europe/)
60. [www1.us.dell.com/content/topics/global.aspx/corp/environment/en/prod\\_design\\_main?c=us&l=en&s=corp](http://www1.us.dell.com/content/topics/global.aspx/corp/environment/en/prod_design_main?c=us&l=en&s=corp)
61. [www.hp.com/hpinfo/globalcitizenship/environment/](http://www.hp.com/hpinfo/globalcitizenship/environment/)
62. [www.ind.tno.nl/product\\_development/sustainable\\_concepts/dfe/dfehome.html](http://www.ind.tno.nl/product_development/sustainable_concepts/dfe/dfehome.html)
63. Goodall RM, Kortüm W (2002) Mechatronic developments for railway vehicles of the future. Control Engineering Practice, 10(8): 887–898
64. Hyung-Woo Lee, Ki-Chan Kim, Ju Lee (2006) Review of maglev train technologies. IEEE Trans. Magnetics, 42(7):1917–1925
65. Vuchic VR, Casello JM (2002) An evaluation of Maglev Technology and its comparison with High Speed Rail. Transportation Quarterly, 56(2):33–49
66. Emadi A, Rajashekara K, Williamson SS, Lukic SM (2005) Topological overview of hybrid electric and fuel cell vehicular power system architectures and configurations. IEEE Trans. Vehicular Technology, 54(3):763–770
67. [en.wikipedia.org/wiki/Fuel\\_cell](http://en.wikipedia.org/wiki/Fuel_cell)
68. Green JE (2005) Future aircraft – greener by design? Meteorologische Zeitschrift 14(4):583–590
69. Åkerman JA (2005) Sustainable air transport — On track in 2050. Transportation Research Part D: Transport and Environment, 10(2):111–126
70. Thomas C, Raper D (2000) Sustainable mobility and the air transport industry – Comments on the European Commission's views, Air & Space Europe, 2(3):13–16
71. Daviss B (2007) Green sky thinking, The New Scientist, 193(2592):32–38
72. Leifsson L, Mason WH, The Blended Wing Body Aircraft, Virginia Polytechnic Institute, [www.aoe.vt.edu/research/groups/bwb/papers/The\\_BWB\\_Aircraft.pdf](http://www.aoe.vt.edu/research/groups/bwb/papers/The_BWB_Aircraft.pdf)
73. [en.wikipedia.org/wiki/Blended\\_wing\\_body](http://en.wikipedia.org/wiki/Blended_wing_body)

74. Ackermann, T, *Wind Power in Power Systems*. John Wiley and Sons
75. Clément *et al.* (2002) Wave energy in Europe: current status and perspectives. *Renewable and Sustainable Energy Reviews* 6(5):405–431
76. Peacock AD, Newborough M (2006) Impact of micro-combined heat-and-power systems on energy flows in the UK electricity supply industry. *Energy* 31(12):1804–1818
77. [en.wikipedia.org/wiki/Heat\\_pump](http://en.wikipedia.org/wiki/Heat_pump)
78. Bi ZM, Lang SYT, Shen W, Wang L (2008) Reconfigurable manufacturing systems: the state of the art. *Int. J. Production Research* 46(4):967–992
79. Shu-Hsien Liao (2005) Expert system methodologies and applications—a decade review from 1995 to 2004. *Expert Systems with Applications* 28(1):93–103
80. Biddiss E, Beaton D, Chau T (2007) Consumer design priorities for upper limb prosthetics. *Disability & Rehabilitation: Assistive Technology* 2(6):346–357
81. Ohnishi K, Weir RF, Kuiken TA (2007) Neural machine interfaces for controlling multifunctional powered upper-limb prostheses. *Expert Review of Medical Devices* 4(1):43–53
82. Bonato P (2005) Advances in wearable technology and applications in physical medicine and rehabilitation. *J. NeuroEngineering and Rehabilitation* 2(2), doi:10.1186/1743-0003-2-2
83. Riener R, Nef T, Colombo G (2005) Robot-aided neurorehabilitation of the upper extremities. *Medical & Biological Engineering & Computing* 43(1):2–10
84. Ball SJ, Brown IE, Scott SH (2007) MEDARM: a rehabilitation robot with 5DOF at the shoulder complex. *IEEE/ASME Int. Conf. Advanced Intelligent Mechatronics*: doi: 10.1109/AIM.2007.4412446
85. Wootton R, Dimmick SL, Kvedar JC (editors) (2006) *Home Telehealth: Connecting Care with the Community*. Royal Society of Medicine
86. Ashby MF, Bréchet YJM, Cebon D, Salvo L, (2004) Selection strategies for materials and processes. *Materials & Design* 25(1): 51–67 doi:10.1016/S0261-3069(03)00159-6
87. Sapuan SM (2001) A knowledge-based system for materials selection in mechanical engineering design. *Materials & Design* 22(8):687–695 doi:10.1016/S0261-3069(00)00108-4
88. [www.grantadesign.com/products/ces/](http://www.grantadesign.com/products/ces/)
89. [unfccc.int/2860.php](http://unfccc.int/2860.php)
90. [unfccc.int/files/meetings/cop\\_13/application/pdf/cp\\_bali\\_act\\_p.pdf](http://unfccc.int/files/meetings/cop_13/application/pdf/cp_bali_act_p.pdf)
91. Stern N (2007) *The Economics of Climate Change: The Stern Review*. Cambridge University Press
92. [www.imeche.org/industries/mic/about/mechatronics-working-group/](http://www.imeche.org/industries/mic/about/mechatronics-working-group/)

# Chapter 2

## Consumption to Contribution: Sustainable Technological Development Through Innovation

John H. Millbank<sup>1</sup>

### 2.1 Introduction

Sustainability issues have been driven to the top of the political, economic and societal agenda, particularly in regard to unremitting consumption of finite resources and its impact on environmental degradation.

In her landmark, but at the time (1962) controversial book, *Silent Spring* [1], Rachel Carson drew to the world's attention the impact of pesticide use on wildlife, opening the debate on environmental degradation. This was followed a decade later by *The Limits to Growth* [4], an equally controversial study on behalf of the Club of Rome.<sup>2</sup>

However, it was not until the Brundtland Report appeared in 1987<sup>3</sup> that issues of sustainable development began to be taken seriously. These issues were taken up by the business world with respect to:

How the business community can adapt and contribute to the crucial goal of sustainable development which combines the objectives of environmental protection and economic growth.

This occurred under the auspices of the Business Charter for Sustainable Development in the publication *Changing Course* [5].

The aim of the present chapter is to provide an introduction to 'applied' sustainable approaches to technological development through innovation designed to secure 'triple bottom line' outcomes<sup>4</sup>.

---

<sup>1</sup> Technology Transfer Consultant, UK

<sup>2</sup> Other notable commentary from around that period was by Commoner in *The Closing Circle* [2], and Dubos and Ward in *Only One Earth* [3].

<sup>3</sup> See Chapter 1

<sup>4</sup> The triple bottom line is defined as: society depends on the economy and the economy depends on the global ecosystem, whose health represents the bottom line [6].

## 2.2 The Interpretation of Meaning for Sustainability and Innovation

The terms innovation and sustainability have become widely appropriated in academic literature as well as by the popular press to convey an imperative related to future economic, social and environmental wellbeing. Moreover, these terms are very often juxtaposed to imply change from the *status quo* to more conducive conditions. Unfortunately, in this context they are amorphous and consequently their definitions have come to mean different things to different people. For example, the business community may regard innovation as a means by which to secure longer term sustainable commercial advantage and leverage whereas societal interpretations will, in general, be wholly concerned with affecting change leading to stability and global longevity. Understandably, therefore, there is a need to adopt an interpretation for both sustainability and innovation which in the case-based approach of the present book meets the needs of science, technology and engineering practitioners as applied to mechatronic system development.

The (UK) Department of Trade and Industry<sup>5</sup> offered a simplistic and rather anodyne definition of innovation as [7]:

The *successful* exploitation of new ideas, products, materials, techniques and processes.

In contrast, the Brundtland definition<sup>6</sup> of sustainability is more emphatic. However, for the purpose of this discussion, both definitions remain inconclusive. Therefore, an attempt to follow the more rigorous interpretations offered by the Council for Science and Technology [8] for innovation, and Charter for sustainable innovation [9] provides the basis for delineating the consumption to contribution debate.

Innovation is the process by which ideas and knowledge are exploited for business purposes. It encompasses not only the creation of a new product, process or service, but also the systems, processes, organisations, structures and all other aspects of a company's existing or future competitive edge such as distribution, marketing, branding and indeed the creation of a brand new market. The process draws on a range of intellectual and other inputs including knowledge of markets, customers, competitors, science, engineering and technology (CST).

Sustainable Innovation is a process where sustainability considerations (environmental, social, and financial) are integrated into company systems from idea generation through to research and development (R&D) and commercialisation. This applies to products, services and technologies as well as new business and organisational models [9].

---

<sup>5</sup> Now remodelled as the Department for Business, Enterprise & Regulatory Reform, whose innovation home page defines the process as '*the successful exploitation of new ideas*'; a further dilution of meaning. The original DTI online document has been deleted; the archive of which is reported to be with the British Library.

<sup>6</sup> Chapter 1 Op. cit.

Thus, a context is established from which to explore the contribution that mechatronic engineering and technology practitioners can provide towards reducing consumption of finite resources, selecting appropriate technologies, ensuring minimum energy usage, eliminating unnecessary waste, extending reliability and endurance, avoiding undesirable duplication, future proofing, end-of-life recovery of component stocks, reducing/negating pollution and toxicity and simplifying functionality through the rationalisation of complexity. Mechatronics is a synergistic discipline which seeks to secure integrated solutions. Under these conditions, a more holistic approach to creating ‘sustainable’ products, processes and systems can result, and thereby engage a perception that:

The whole is more than the sum of the parts – and each part is more than a fraction of the whole [10].

For mechatronic applications, there are several instances where this philosophy may be seen to already be making an impact including:

- combining electroencephalography (EEG) with magnetic resonance imaging (MRI) [11];
- control software integration [12] for investigations into epilepsy [13];
- the Combined Active and Passive Safety System (CAPS) for automotive applications under development by Bosch and others [14, 15];
- micro-electromechanical systems (MEMS) arrays offering the possibility of thousands of individual components to function in isolation or combined to enable complex actions [16–18].

### **2.3 Deconstructing Technological Innovation as a Driving Force for Sustainable Engineered Systems**

Innovation, as such, is regarded as both a cause and solution to much of the structural, environmental and social impact issues surrounding economic development [19]. Yet, it is argued that technological innovation lies at the heart of attempts to secure sustainable ‘engineered’ system outcomes for longer term social and economic gain and in turn should be appropriated to advance environmental sustainability. This contrasts with systems innovation where broader concerns are primarily directed towards organisational, architectural, socio-political, and socio-technical issues within the sustainability framework [20].

In recent years, linear models of innovation<sup>7</sup> have been largely discredited [22] as inadequate descriptors for differentiating the various and often complex processes in translating concepts to a marketable conclusion. While the

---

<sup>7</sup> As a sequential and unidirectional process having five functional phases comprising: idea generation > invention > R&D > application > diffusion [21]

interactive, systems-based model offered by Rothwell [23] does overcome many of the shortcomings of its predecessors, it still fails to take account of the need to incorporate environmental impact and sustainability considerations, or indeed the influence of moral imperatives [24]<sup>8</sup>. This is further aggravated by the requirement, for instance, to absorb within the process energy demands [26] and water consumption [27] both during system configuration and lifetime usage (and possibly disposal). As Rosenburg [28] points out with respect to energy consumption:

Nor is it sufficient to examine only the energy efficiency involved in the manufacture of a product; equally important are the energy-using requirements of the product over the course of its own life cycle.

One of the early attempts to address environmental concerns and sustainability within an entrepreneurial framework of technological innovation was characterised in the work of Martin [29, 30], which provided an outline of ‘technological assessment processes and environmental impact statements’.

As Herkert *et al.* [31] observed:

One of the crucial elements of sustainable development lies in understanding the role that technological innovation plays in the process. Because technology often drives the way in which humans consume resources, create waste, and structure society, its role is significant.

By implication, the transition of a discrete technological innovation to the applications, exploitation and diffusion arena<sup>9</sup> is probably the most important issue for the design engineer as far as sustainable outcomes are concerned. It engages a set of processes where life cycle assessments, materials utilisation, energy efficiencies, and other imports should be addressed both upstream and downstream<sup>10</sup> of the ‘technological transfer’ domain [37].

Rogers and Valente [38] have described technology transfer as:

The process by which technological innovations are exchanged between individuals and organisations who are involved in R&D (but not exclusively) on the one hand, and putting technological innovations into use on the other hand.....Traditionally, it was conceptualised as the transfer of hardware objects, but now often involves information.

Unfortunately, this description omits any reference to fitness-for-purpose, economic configuration, societal acceptance, or indeed environmental and ecological impact factors. Moreover, demonstration of technology in one area of application may not necessarily hold up in another. Thus, the design engineer is faced with the problem of attempting to secure robust functional solutions within

---

<sup>8</sup> Ethical determinants with respect to mechatronic product development have been explored by Searing and Rabins [25].

<sup>9</sup> There are several sources of information on taking ideas to exploitation available. Readers are particularly encouraged to consult [32–36].

<sup>10</sup> Incorporating forecasting, foresight and technological verification assessments

ever more restrictive regimes of outcome conformity, moral conduct, and sustainability promotion.

## 2.4 Forecasting, Foresight and Technology Assessment

Although often regarded as one and the same, there are unique distinctions between forecasting and foresight [39]. The techniques and visualisation tools they employ have special significance for sustainability criteria in technological exploitation for economic, societal and environmental benefit. Both processes are important adjuncts in the technological innovation paradigm [40], and bring urgency to the issues of future consumption, technological progress and environmental tensions surrounding the sustainability debate.

Foresight studies have been advanced over the last twenty years [41], whereas forecasting and technology assessments have been part of the strategic armoury of industrial organisations and government agencies for considerably longer, invoking techniques such as the Delphi methodology, morphological analysis and relevance trees [42, 43]. Nowadays, forecasting might be more closely aligned with that of ‘applications’ foresight to assess, for example, the impact of a well-defined and potentially transferable technology into applications which might not otherwise have been envisaged or intended, such as laser interventions in surgery. Consequently, whereas forecasting is an engagement that attempts to predict future impacts and outcomes precisely, foresight:

*Explores* possible future directions of technological progress and identifies forces that might drive certain developments, and thus provides decision-makers in politics and companies with such types of strategic information [44].

This contrasts to some extent with technology assessments which Coates [45] defines as:

The exploration of primary and secondary consequences of the introduction into society of a new technology or the expansion of an already existing technology.

For the mechatronics system developer and practitioner, the technology assessment approach arguably offers the most appropriate and accessible mechanism in which to incorporate life cycle and environmental impact analysis, for example, into design studies [46] for the promotion of sustainable outcomes. This can be summarised as an exercise of gathering sufficient information about the technological development in terms of resource appropriation, processing, energy premium, anticipated durability, etc. and:

It’s likely future consequences for all those who interact with it, *before* embarking upon developing or deploying this technology [47].

Van den Ende *et al.* [48] offer a classification of the approaches and methods of technology assessment for unification into a common framework, whilst other contributions which have particular significance for mechatronic systems

developers and problem solvers are provided by Gausemeier [49], Fey and Rivin [50],<sup>11</sup> and Kuntze [51]<sup>12</sup>.

Foresight evaluations, by contrast, remain more speculative when attempting to secure practical and robust technical solutions and, in general, remain within the domain of policy and executive decision makers. However, the context with which mechatronics is perceived as a synergistic and unified multi-dimensional discipline embraces the wider imports of social, political, economic and environmental issues.

Nowadays, delineation of foresight perspectives has evolved into a third generation, the first having been ‘driven by the internal dynamics of technology’, the second embracing ‘technology and markets’, and the third being ‘enhanced by the inclusion of the social dimension’ [53]. Within this paradigm, the critical issue of sustainability becomes all too apparent. Borup [54] deals with these concerns within a framework of principles, which addresses:

Production/consumption systems, eco-efficiency, risks & uncertainty, institutional reflexivity, values and visions.

## **2.5 The Influence and Impact of Information and Communication Technologies**

Developments in computer and telecommunications technology have transformed virtually every aspect of economic and social activity in the ‘developed’ world, and increasingly so within developing nations. Whilst it is not possible to deconstruct the pervasiveness, and some would argue invasiveness, of the constituent technologies, there is much to debate in terms of sustainability issues relating to both functional implementation and, more particularly, to environmental impact.

In 1978, Sloman [55] declared that:

It can be argued that computers, or to be more precise, combinations of computers and programs, constitute profoundly important new toys which can give us a new means of expression and communication and help us create an ever-increasing new stock of concepts and metaphors for thinking about all sorts of complex systems, including ourselves.

For the mechatronics practitioner or for that matter anyone else who routinely uses computer-aided, internet-enabled, microprocessor-derived technologies, the consumption to contribution imperative becomes difficult to reconcile and negotiate. A few application-specific examples illustrate just how challenging it is

---

<sup>11</sup> Incorporation of the Theory of Inventive Problem Solving (TRIZ) within forecasting to remove ‘trial and error’ ambiguities

<sup>12</sup> Detailed evaluation and comparison with earlier studies has been carried out by Cuhls *et al.* [52].



to ensure sustainable outcomes which affect net gain for society, the economy and, ultimately, environmental wellbeing.

For instance, email and internet-derived resources *should* have led to the ‘paperless office’ through digital storage and archiving [56]. In fact, evidence strongly suggests otherwise, particularly in the exponential growth in paper consumption for email archiving [57]. Moreover, the provision of internet resources through the World Wide Web and its access to specific topics is only sustainable as long as it remains available and viewable (see footnote 4)<sup>13</sup>. This presents something of a dichotomy in the consumption to contribution debate. However, information flows through email and resources accessed through the World Wide Web do have many advantages as a medium for distributing tacit knowledge, although, whilst information management is well established, the management of knowledge remains in its infancy [58].

There is a notable difference between actively seeking out information and the passive receipt of it. As has been pointed out [59], the Web requires people to actively seek out the information, usually through search engines, whereas email and web blog discussion provides and promotes delivery of information without effort, thus providing an interactive mechanism of knowledge exchange. Furthermore, as a means to document knowledge, internet technologies makes an impact on virtually all aspects of technological development and organisational performance, ranging from scientific enquiry to sustained business and societal administration. Hence, the concept of knowledge and its transference through electronic means reveals distinct attributes as well as limitations.

This is explored by Davenport and Prusak [60], who assert that spontaneous, unstructured knowledge transfer is vital to a firm’s success, and that they should shift their attention from ‘documents to discussion’. They go on to describe the ‘velocity’ and ‘viscosity’ of knowledge transfer; velocity being the speed at which knowledge moves through an organisation and viscosity referring to the richness (or quality) of the knowledge transferred, and that these components are often at odds with each other. This can result in information overload and in the context of email, which was originally designed as a communications application, is often used for task management and personal archiving for which it was never intended [61].

The knowledge-based economy, through the implementation of information and communication technologies, has been described routinely as ‘weightless’ [62] since it was supposed to reduce dependence upon physical stocks of natural resources. However, this argument has been challenged in a societal as well as industrial economic context [63] and, more critically, within a sustainability setting [64] due to rebound effects of consumption. These are created by the proliferation of computer hardware, its obsolescence and redundancy, energy

---

<sup>13</sup> For this reason, hyperlink referencing within this chapter is, in general, confined only to documentation which would otherwise not be available through published ‘sustainable’ (*sic*) paper format. Another shortcoming is that, even with full html, pdf, etc. citing, direct access may be limited by filtering or by subscription registration by the user.

requirements for both powering and cooling an ever increasing demand for processing capacity as well as an expanding array of short life span consumer devices. Munn *et al.* [65] have examined the environmental and social implications of these issues and draw attention to the fact that in 1999, the average lifespan for a computer in the USA was between four and six years, whereas by 2005, it had dropped to less than two years <sup>14</sup>.

Energy consumption also features as a primary concern not only in the power requirements to run massive data servers, but also in the need for cooling such installations [67]. Energy aware thermal management approaches [68] that deal holistically with the path of heat flux from the chip, through the system enclosure and out to the environment provide a mechanism for taking energy consumption issues seriously.

## 2.6 Consumption, Obsolescence and Moves Towards Future Proofing

Consumption and growth have been synonymous since the beginning of the first industrial revolution and, indeed, some economists would argue that it remains nothing less than the purpose of the economy [69]. Now in the ‘information age’, the world is faced with tensions of unprecedented demand for ‘material’ consumption to support technological progress together with ever increasing energy requirements, with which to stimulate consumer demand as well as to encourage take-up of newer technological artefacts and processes as they emerge. Inevitably, attendant resource depletion, waste generation and disposability problems have become *the* major contemporary sustainability issue [70] although, from a historical perspective, dealing with waste together with the concepts of Reduce – Recycle and Reuse over the past century [71] can be traced back thousands of years [72].

The impacts of the (current) IT revolution and its technological antecedents and derivatives were anticipated three decades ago when the notion of ‘responsible consumption’ [73] was first proposed. However, it is also now widely recognised that a transition to sustainable consumption demands greater urgency to ensure that quality of life and lifestyle can be maintained and enhanced [74, 75]. This is a subtle distinction since, whilst responsible consumption reflects rational and efficient use of resources, sustainable consumption invokes net societal and environmental gain. In order to support such objectives, it is essential to encourage more radical innovative approaches in the use and application of materials,

---

<sup>14</sup> The Deploy project (funded through the European Commission) aims to provide formalised engineering methods to secure dependable and more robust hardware across a range of industrial sectors, including transportation, automotive, space (satellites), telecommunication (mobile phones) and business information (computers), in particular dealing with pervasiveness and complexity [66].

technology and energy inputs. Therefore, an embedded business model and societal culture should be encouraged which seeks to eliminate unnecessary waste altogether, invoke only wholly renewable energy contributions<sup>15</sup> and rationalise essential natural resource extraction to avoid depletion. This is an ideal which may only occur through a revolutionary approach and outcome.

Reducing obsolescence and redundancy is a primary area to address since disposability has been the hallmark of the business world as well as that of consumers for too long. Its perceived survival and continued growth has been dependent on encouraging continued patterns of consumption [78] through limited life-cycle functionality (intended or otherwise), or the adoption of newer technologies as they become viable. Moreover, the acceleration of obsolescence, particularly in ICT, results in a loss of valuable knowledge as well as creating social disruption [79]. By contrast, customised low volume capital intensive products and processes (such as can be found in ships, aircraft, industrial plants and other large scale equipment) have problems with reconciling obsolescence, since they remain in service for many decades [80]. This, in itself, necessitates a step-change innovation in organisational response to secure product life longevity, to eliminate redundancy and, ultimately, demonstrate sustainable business practices. Understanding the factors which determine product obsolescence is an important consideration [81] and integrating obsolescence forecasting into the product design process can secure more sustainable outcomes [82].

Future proofing<sup>16</sup> is the generic form of ‘obsolescence forecasting’ and as such is a relatively new concept. It has evolved mainly through the business world to anticipate organisational needs and responses to changing business environments [83]. However, application specific areas – such as ICT industries seeking to ensure future compatibility of software for extended applications or system integration – indicate that the concept can be applied to more basic technological development areas such as sustainable automotive mobility [84]. Naturally, this offers an opportunity for the design practitioner to engage and integrate many of issues posed by earlier arguments surrounding environmental impacts and consequences of consumption and waste, by invoking foresight exercises [85] into decision processes as well as other approaches such as technology roadmapping [86, 87]<sup>17</sup>.

Unfortunately, demand only aggravates the consumption problem and the economy response to stimulate that demand through promotion of more than is actually wanted or necessary [88] by the business community in order to secure

---

<sup>15</sup> An example of efforts to address these issues [76] together with a wider ranging brief to promote Technologies for Sustainable Development may be found within an initiative set up in 2001 by the Austrian Federal Ministry of Transport, Innovation and Technology [77].

<sup>16</sup> Describes the ambiguous process of attempting to anticipate future developments, such as to avoid obsolescence

<sup>17</sup> Roadmapping is a requirements-derived technology planning process which assists in the identification, selection and development of technology alternatives to satisfy a set of product outcomes, and is particularly suitable for evaluation against environmental impact and sustainability criteria.

profit ‘bottom line’ objectives (See footnote 3). These are complex economic and sociological issues involving both product and process innovation, detailed examination of which remains beyond the scope of this chapter.

## 2.7 Complexity Paradigms Within a Sustainability Context

Technological innovation is increasingly concerned with complex products and processes [89], and even components and subsystems such as microprocessors or aircraft jet engines have evolved into highly complex technologies in their own right [90]. A failure in subsystems and components within a fully integrated mechatronic system will inevitably result in malfunction or inoperability of the whole product, process or equipment. Of course, a subsystem or component may not have failed, but just need replacement as part of an upgrading or improvement in functionality. In highly customised, capital intensive products (such as aircraft), many organisations and resources will be mobilised [91] to resolve the subsystem failure or upgrade. Moreover, a range of core capabilities will be retained and enhanced to deal with subsystem improvements and further system integration as they are developed over time [92].

By contrast, in mass produced commodity systems such as personal computers, for economic reasons, there may be no incentive or even possibility to attempt repair due to the complex nature of the failed component. This applies equally to a working system which may be perceived as having become functionally inadequate as a result of greater demands being placed on its processing capacity. This poses a moral dilemma [93], particularly in abandonment and disposal of the failed or working component (microprocessor) or, indeed, the whole system.

Adoption of concurrent engineering methodologies for complex systems may to some extent offer benefits of sustaining balanced stakeholder satisfaction over time [94], together with the adoption of platform-based development of product families [95] to improve longevity. Moreover, there are indications that efforts are being made to reduce the increasing energy premiums associated with the massive growth in processing capacity for ICT applications particularly within data server domains. For example, voltage and frequency scaling for computer hardware and HVAC<sup>18</sup> cooling infrastructure lowers energy consumption by reducing microprocessor performance during periods of low utilisation [96]. New generations of multi-core processors are being marketed for improved multi-tasking performance which also offer substantially reduced power consumption [97]. Of course, this all tends to add to the complexity paradigm, although even here, there are indications that attempts are being made to reduce complexity both in product design [98] as well as across the software-driven user interface [99]. However, obsolescence, redundancy and deficiency cannot be eliminated

---

<sup>18</sup> Heating, ventilation and air conditioning

completely. Consequently, the burden of consumption and its associated waste generation as well as the need for process handling remain inconclusive.

## 2.8 Rationalising Material Selection and Processing

Material consumption, along with its raw resource extraction and industrial processing, underlies and influences all technology-based outcomes whether they manifest themselves as consumer products or major capital intensive structures. Rationalising material selection to meet environmental objectives is, therefore, of greatest concern in product life cycles in terms of production, manufacture, use and disposal [100].

Manufacturers are beginning to adopt more sustainable material selection practices with the automotive sector, for instance, engaged in utilising more recycled materials into vehicles [101] as well rationalising design approaches to recycle-ability through its use of software tools such as *euroMat* [102]. However, of particular environmental concern is the widespread use of hydrocarbon derived plastic materials and the extent to which they lend themselves to recycling, reuse or, in the worst scenario, abandonment in landfills.

As an engineering material, plastics are the fastest growing group of bulk materials used in high income economies and have overtaken aluminium and glass in terms of mass quantities used [103]. Unfortunately, in sustainability terms, attempting to substitute plastic materials used, for example, in packaging applications with materials such as paper, glass or aluminium may be perceived as more eco-friendly, but adds to the overall weight, volume, cost and energy consumption [104]. Thus, the ubiquitous plastic-injection moulding together with more basic sheet and film variants form major structural components of virtually all consumer-oriented and industrial/commercial use products nowadays. Moreover, due to its versatility, form and function complexity, cheapness, reproducibility, range of engineering properties and mass-produceability, it enables structural configurations that would not be possible to create by any other 'one-shot' application. As such, plastic injection mouldings have become ever more sophisticated in their applications over the past 60 years. Therefore, the method of bulk material processing or recycling [105] together with injection moulding techniques (hydraulic, hybrid, all-electric) also becomes significant, particularly in terms of energy consumption [106].

Although conventional plastics are derived from finite hydrocarbon sources, they do lend themselves to energy recovery potential at the end of product life in certain instances [107], particularly where they cannot be recycled or reused. However, a more rational approach for the system designer is to adopt a cradle-to-

grave analysis to material flows [108], whereby energy and waste are considered at each stage of development and processing<sup>19</sup>.

Biodegradable polymers [112, 113], by contrast, afford an alternative to ‘conventional’ plastics altogether, whereby environmental impacts are virtually eliminated through natural decomposition over a given timeframe. However, some early attempts within the European community to encourage industry to promote and prescribe the use of bio-plastics were not successful due to ‘structural tensions’ [114]<sup>20</sup>; a particular example being starch-based plastic coatings of electrical wiring which, in service, suffered premature decomposition. However, much progress is being made in improving structural performance in the case of electric wiring [116] and in consumer products in general, particularly injection-moulded electrical goods such as DVD players, computer casings, etc. [117]<sup>21</sup>.

A major health issue associated with using, for example, conventional (PVC) polymers is that the vinyl chloride monomer is a known carcinogen. Additionally, in wiring applications, for instance, the inclusion of lead compounds (which produces good heat stabilisation characteristics) is considered both a health and environmental hazard [120]. Unfortunately, lead (together with several other widely used heavy metals commonly found in products and processes) require special considerations for disposal, due to toxicity. Consequently, elimination of lead and other heavy metals altogether from routine use is seen as an imperative<sup>22</sup> and, as such, forms a central plank of recent EU legislation. Under its directive on the restriction of the use of certain hazardous substances [122], it calls for substitution of various heavy metals and, more particularly, on waste electrical and electronic equipment (WEEE) which addresses the fast increasing waste stream of electrical and electronic equipment [123]. Nonetheless, there are instances where good intentions associated with the elimination of heavy metal compounds have resulted in unintended outcomes. For example, the requirement to use only lead-free solder in electrical circuit applications [124] can result in a phenomenon known as ‘tin whiskers’ [125, 126]. Over time, the condition sometimes results in catastrophic short circuits in electronic components, rendering complete system failures and possible abandonment; hardly a move towards sustainability.

Thus, rationalising material selection and processing necessitates a holistic approach to integrating sustainability, as typified within the MATISSE project [127]. As Ritthof [128] points out:

---

<sup>19</sup> More general reference to plastics and polymeric product life cycle assessment within the context of environmental impact and sustainable outcomes can be found in [109–111].

<sup>20</sup> Further explanation on the origins and interpretation of the term ‘structural tension’ within an innovation context is given by Carlsson *et al.* [115].

<sup>21</sup> Current research into the utilisation of polymer-clay nanocomposites aims at improving structural properties such as tensile strength [118] and thermal plasticity [119] as well as offering more bespoke timeframes for biodegradability.

<sup>22</sup> The E-waste recycling of printed circuit boards is a recent example [121].

The principal task for engineers, designers, architects and natural scientists is to create products and systems that allow the extraction of a maximum amount of utility from the least possible quantity of nature for the longest possible time with the least possible use of space. In short: in products for sustainability, mass, space, need and energy have to be replaced by brainpower.

This begs the question of to what use will the product be applied and what are the material requirements [129]? In either situation, it suggests that in its broadest sense [130], dematerialisation considers reductions in base material consumption, whilst retaining, enhancing and maximising utility value.

One such example considers the microchip, where perceived utility value is high but product weight remains negligible [131]. However, secondary influences impact overall sustainability value<sup>23</sup> due to the ‘complementary assets’ [133] and consuming infrastructure needed to create the product in the first place, whether in small or massive quantities. These constraints might equally be applied to whole new ranges of ‘smart structures’ and technologies being developed for industrial and consumer applications [134–136], many of which fall within the armoury of the mechatronics systems developer or practitioner. However, their utility value must be verified in absolute terms through generic dematerialisation, if practicable, whilst retaining or improving functionality and minimising environmental impact. This calls for innovative procedures in systems development that explores complete life cycle and sustainability assessments as a priority and likewise for subsequent manufacturing and distribution in the marketplace.

## 2.9 Conclusion – From Responsible Design to Resource Recovery

For the mechatronics practitioner, the facility to incorporate whole life parameters into product developments and application should be seen as a fundamental objective in order to promote and secure sustainable system outcomes. The synergistic nature of the discipline, whereby the whole is perceived as greater than the sum of its parts, naturally leans towards integrated solutions. However, there are both positive and negative aspects of this synergy which can impact the quest for seeking sustainable mechatronic systems and products [137] such as reliability, maintainability and supportability; an example is the influence of structural fatigue and its damage consequences for whole life system performance [138]. Moreover, intentional ‘short-life’ product design, in order to encourage and simulate end user consumption, has no place in the eco-design philosophy [139].

In many ways, this poses yet another ethical dilemma for the system designer which had been alluded to some thirty years ago by Overby [140] who asked:

---

<sup>23</sup> Computer chips have a high environmental impact relative to weight [132] in terms of energy input throughout their manufacturing cycle.

Is the idea of product design for a more sustainable future a matter of ethics, or is it simply a response to pragmatic circumstance – or is it some of both?

Pragmatism dictates that products and processes will evolve as newer functional technologies emerge, which may (or may not) be superior in performance terms from their predecessors, but are exploited to promote efficiency gains, manufacturing cost reductions, competitive advantage, etc. However, the system designer, and engineers in general, hold a duty of care and responsibility to ensure that technologies they prescribe meet ethical discourse criteria [141]. In order to ensure sustainable technology outcomes [142], engineers should ask themselves which types of situations require ethical reflection, and to what extent they should assume moral responsibility in the practice of their profession?. This can be summarised in terms of the sometimes onerous obligations placed on engineers to protect both the environment and public interest, where Alpern [143] declared:

Engineers have a duty to make personal sacrifices in calling attention to defective design, questionable tests, dangerous products, and so on...

Thus, sustainable engineering incorporates ethical, social and ecological dimensions into the design of products and processes that will benefit society in general, and environmental imperatives in particular. By invoking not only moral questions of ‘fitness for purpose’, fundamental issues of environmental impact assessment, lifecycle thinking, preventing waste, minimising the depletion of natural resources and so on, in a holistic manner [144], also holds sway. This philosophy then aggregates with the Brundtland dictum of development that meets the needs of the present without compromising the ability of future generations to meet their own needs.

For the design engineer and, more particularly, the mechatronic system developer, there are now a growing number of online resource tools available to deal with these challenging issues [145, 146] as well as hardcopy sources for application specific areas of design and manufacturing for sustainable development; examples include [147–149]. However, of all the design and application challenges that the developer faces, life cycle assessment (LCA) perhaps poses the most arduous of tasks since it incorporates many contrasts in adaptation and interpretation that can extend from sustainable consumption and resource recovery through self-disassembling products, to products that are never discarded [150]. Moreover, the now accepted standard approach to LCA tends to be directed downwards towards lower system levels resulting in optimised components within products rather than optimised products within their surroundings [151]. It is therefore necessary to invoke the broader perspective of industrial eco-systems [152]<sup>24</sup> which Tibbs [154] attributes to being:

---

<sup>24</sup> Frosch and Gallopoulos, in their seminal article [153], introduced the notion of the industrial ecosystem which would function as an analogy to biological ecosystems, that is, *‘plants synthesise nutrients that feed herbivores, which in turn feed a chain of carnivores whose wastes and bodies eventually feed further generations of plants.’*



...a logical extension of life-cycle thinking, moving from assessment to implementation. They involve ‘closing loops’ by recycling, making maximum use of recycled materials in new production, optimising use of materials and embedded energy, minimising waste generation, and revaluating ‘wastes’ as raw material for other processes.

Naturally, end of life treatment for products and processes is only a reactive response to considerations which should be addressed much earlier in the formation and manufacturing phase (and preferably from the design stage [155]), particularly material flows [156], dematerialisation [157] and energy flows (during configuration and anticipated lifetime usage) [158]. Nonetheless, the designer may be constrained by the path dependent nature of technology evolution [159, 160], whereby complex technologies become interactive and dependent upon the availability of complementary technologies<sup>25</sup> for their final system integration [162]. However, technological evolution often provides for many step change enhancements over predecessor technologies. They can result in substantial reductions in material consumption and product configuration complexity without loss of functionality and, in some instances, additional functional improvement. Two recent promising examples are a ‘\$10 microscope’ based on opt-fluidics and optics [163] and a ‘bionic eye’ based on compressible silicon optoelectronics [164]<sup>26</sup>. Both developments appear to offer substantial utility value combined with significant dematerialisation, although it remains unclear whether the associated complementary technologies needed contribute an overall sustainability improvement.

For the most part, the concept of environmentally benign and optimally sustainable product outcomes remains a pipe dream, and the system developer will be forced to accommodate contingency for end of life handling provision (particularly under legislative directives, such as WEEE, etc.). Nonetheless, there are some *inter alia* assessment criteria that can be called upon to delay the advancement of end of life provision such as incorporating reliability [165] and maintainability [166] into the design evaluation process as well as attempting to ‘future proof’ or at least seek to predetermine useful product life [167]. Beyond this, the designer will need to apply an armoury of techniques and disassembly modelling for recycling and reuse [168]. This then paves the way to deal with resource recovery in a structured manner when applied to product and material cycles [169].

Mechatronic and IT-based products and systems, particularly those in the consumer domain, tend to have shorter life spans nowadays and, as such, accelerate the urgency to accommodate ‘mass’ resource recovery [170, 171]. However, resource recovery also creates a dilemma in decisions affecting the extent to which products can be repaired, reconditioned, remanufactured or

---

<sup>25</sup> These are technological assets which are peripheral to the main ‘innovation’ thrust, but may [nonetheless] prove vital to complement and support ‘sustainability’ (*sic*) of the development programme. They may also require some adaptation to ensure ‘fitness for purpose’ which is typically found in mechatronic systems’ [161].

<sup>26</sup> Both developments were reported in the national and international press during 2008.

recycled. Moreover, new and emerging technologies tend to undermine attempts to optimise complete resource recovery for existent product stocks due to obsolescence. It would seem, therefore, that remanufacturing appears to offer the best strategy for mitigating unsustainable outcomes. For example, ‘it enables the embodied energy of virgin production to be maintained’ [172], although the full societal benefits will not be realised unless provision for remanufacturing is incorporated into the product development process in the first place [173].<sup>27</sup>

Looking further beyond ‘end of product life’ strategies is a wider socio-economic issue [176] and one that requires a radical approach to triple bottom line enquiry, particularly in terms of material selection [177]. Above all, however, is the need to adopt a systems thinking approach in order to push the sustainability agenda forward [178] and one which should sit well with the integrated and innovative nature of the mechatronics discipline. Thus, the connectivity between sustainability and innovation becomes a dominant theme [179] which can either facilitate or present barriers to sustainable futures [180]. Environmental technologies will make way for sustainable technologies where ‘environmental performance considerations will be fully integrated with economic, social and other operational issues so that the system as a whole is sustainable’ [181], *The Triple Bottom Line*.

## References

1. Carson R (2000) *Silent Spring*. Penguin Classics, London.
2. Commoner B (1972) *The Closing Circle: Confronting the Environmental Crisis*, Jonathan Cape, London.
3. Dubos R, Ward B (1972) *Only One Earth: The Care and Maintenance of a Small Planet*. Penguin, Harmondsworth.
4. Meadows DH *et al.* (1974) *The Limits to Growth*, Pan Books, London.
5. Schmidheiny S (1992) *Changing Course: A Global Business Perspective on Development and the Environment*, MIT Press.
6. Elkington J (1999) *Cannibals with Forks: The Triple Bottom Line of 21st Century Business*, Capstone Publishing, Oxford.
7. Department of Trade and Industry (1999) *Science and Innovation Strategy: Consultation Paper*, DTI, London.
8. Council for Science and Technology (2000) *Technology Matters: Report on the exploitation of science and technology by UK business*, Department of Trade and Industry, London, Annex C.
9. Charter M, Clark T (2007) *Sustainable Innovation*. Centre for Sustainable Design, University of Surrey: 9.
10. Elliott C, Dearsley P (2007) *Creating systems that work: Principles of engineering systems for the 21st century*. The Royal Academy of Engineering:14.

---

<sup>27</sup> A typical application of mechatronic remanufacturing in automotive components can be found in Steinhilper *et al.* [174] together with ‘Design for Remanufacture Guidelines’ augmented by UK industrial case-based examples [175].

11. Alper J (1993) EEG+MRI: A sum greater than the parts, *Science*, J. American Assoc. for the Advancement of Science) y, **261** (5121):529–633.
12. Sourceforge, Bioelectromagnetism MATLAB toolbox  
[www.eeg.sourceforge.net/bioelectromagnetism.html](http://www.eeg.sourceforge.net/bioelectromagnetism.html)
13. So EL (2000) Integration of EEG, MRI, and SPECT in Localizing the Seizure Focus for Epilepsy Surgery. *Epilepsia*, **41** (Suppl. 3):548–554.
14. Bosch Safety Network, Field Guide to Automotive Technology,  
[www.autofieldguide.com/articles/wip/0705wip09.html](http://www.autofieldguide.com/articles/wip/0705wip09.html)
15. De Lange, R. (2007) Intelligent Safety Systems Integrating Active and Passive Safety. 7th European Vehicle Passive Safety Conf., Maastricht:20  
[www.passivesafety.com/06\\_publications/proceedings.html](http://www.passivesafety.com/06_publications/proceedings.html)
16. Vittorio SA (2001) MicroElectroMechanical Systems. CSA  
<http://csa.com/discoveryguides/mems/overview.php>
17. Pons JL (2005) Emerging Actuator Technologies: A Micromechatronic Approach. Wiley, UK.
18. Madou M (2002) Fundamentals of Microfabrication: The Science of Miniturization. 2nd ed., CRC Press.
19. Berkhout F, Green K (2002) Managing Innovation for Sustainability: The Challenge of integration and Scale, *Int. J. of Innovation Management*, **6** (3):227–232
20. Elzen B, Geels FW, Green K (Eds.) (2004) System Innovation and the Translation to Sustainability: Theory, Evidence and Policy. Edward Elgar, UK.
21. Kelly P *et al.* (1986) Introducing Innovation. Product Design and Technological Innovation (Eds. Roy R, Wield D), Open University Press, UK.
22. Godin B (2006) The Linear Model of Innovation: The Historical Construction of an Analytical Framework. Project on the History and Sociology of STI Statistics: Working Paper 30, *Science, Technology and Human Values*, **31** (6): 639–667
23. Rothwell R (1992) Successful industrial innovation: critical factors for the 1990's. *R&D Management*, **22**(3):.236
24. Vesilind PA, Gunn AS (1998) Engineering, Ethics, and the Environment. Cambridge University Press, UK.
25. Searing DR, Rabins MJ (1999) Ethics in Product Design. *Mechatronics in Engineering Design and Product Development* (Eds. Popovic D, Vlačić L), Marcel Dekker, New York:585–606.
26. Goldemberg J *et al.* (1988) Energy for a Sustainable World. Wiley Eastern, New Delhi, India:85–93
27. Gerbens-Leens PW, Hoekstra AY (2008) Business Water Footprint Accounting: A tool to assess how production of goods and services impacts on freshwater resources worldwide. UNESCO-IHE Institute for Water Education, Delft, March  
<http://www.waterfootprint.org/Reports/Report27-BusinessWaterFootprint.pdf>
28. Rosenburg N (1994) Exploring the Black Box: Technology, economics, and history, Cambridge University Press,:188
29. Martin MJC (1984) Managing Technological Innovation and Entrepreneurship. Reston Publishing:106–117
30. Martin MJC (1994) Managing Innovation and Entrepreneurship in Technology-Based Firms. Wiley, New York:145–148
31. Herkert JR, Farrell A, Winebrake JJ. (1996) Technology Choice for Sustainable Development. *IEEE Technology and Society Magazine*, Summer
32. Bradbury JAA (1989) Product Innovation: Idea to Exploitation. Wiley, UK.
33. Dodgson M (2000) The Management of Technological Innovation: An International and Strategic Approach, Oxford University Press, UK.
34. Rogers EM (1995) Diffusion of Innovations 4th ed. The Free Press, New York.
35. Tether B (2003) What is Innovation?: Approaches to Distinguishing New Product and Processes from Existing Products and Processes. Centre for Research on Innovation and Competition (CRIC Working Paper No. 12), University of Manchester, August

36. Innovation: Key Innovation concepts & definitions, Institute for Manufacturing, Cambridge University, <http://www.ifm.eng.cam.ac.uk/ctm/idm/innovation/default.html>
37. Millbank JH (2002) A Framework for Technology and Knowledge Transfers as Primary Drivers for Competitive Advantage. 2002 IEEE Int. Engineering Management Conf., Cambridge:410
38. Rogers EM, Valente TW (1991) Technology Transfer in High technology Industries. *Technology Transfer in International Business* (Eds. Agmon T, Von Glinow MA), Oxford University Press, UK:104
39. Voß J-P, Truffer B, Konrad K (2006) Sustainability Foresight: reflective governance in the transformation of utility systems. *Reflective Governance for Sustainable Development* (Eds. Voß J-P *et al.*), Edward Elgar, UK:165–167
40. Cuhls K (2003) From forecasting to foresight processes – new participative foresight activities in Germany. *J. of Forecasting, Special Issue on Technology Foresight*, **22** (2-3):93–111.
41. Martin BR, Irvine J (1989) *Research Foresight: Priority-Setting in Science*. Pinter, London.
42. Martino JP (1992) *Technological Forecasting for Decision Making*. McGraw-Hill, New York.
43. Twiss BC (1992) *Forecasting for Technologists and Engineers*. Peter Peregrinus, UK.
44. Inzelt A, Coenen R (1996) Introduction. *Knowledge, Technology Transfer and Foresight* (Eds. Inzelt A, Coenen R), Kluwer, pXVI/XVII.
45. Coates JF (2001) Future and Technology Assessment Research for Business Clients. Inaugural Meeting of the Center for Impact Assessment Studies and Forecasting, Warsaw, October, [josephcoates.com/pdf\\_files/263\\_Future\\_Research\\_for\\_Biz.pdf](http://josephcoates.com/pdf_files/263_Future_Research_for_Biz.pdf)
46. Porter AL (1995) Technology Assessment, Impact Assessment. *Int. Association for Impact Assessment*, **13**, Summer
47. Braun E (1998) *Technology in Context: Technology Assessment for Managers*, Routledge, London.
48. Van den Erde *et al.* (1998) Traditional and Modern Technology Assessment: Towards a Toolkit – A Research Methodology and Learning Strategy for Social Impact Assessment. *Technological Forecasting and Social Change*, **58** (1):5–17.
49. Gausemeier J (2005) From Mechatronics to Self-Optimization: A New Approach to Shape the Future of Mechanical Engineering. *Enabling Technologies for the New Knowledge Society*, 3rd Int. Conf. on Information & Communication Technology, Cairo [www.hni.uni-paderborn.de/uploads/media/Manuskript\\_ICICT\\_Kairo.pdf](http://www.hni.uni-paderborn.de/uploads/media/Manuskript_ICICT_Kairo.pdf)
50. Fey VR, Rivin EI (1999) Guiding Technological Evolution. *TRIZ Journal*, January [www.triz-journal.com/archives/1999/01/c/default.asp?action=print](http://www.triz-journal.com/archives/1999/01/c/default.asp?action=print)
51. Kuntze U (1999) Resource-Efficient Technologies: Results and Methodological Aspects of the German Delphi '98 Survey. *Proc. of OECD Technology Foresight and Sustainable Development Workshop*, Budapest:26–48
52. Cuhls K, Blind K, Grupp H. (2002) *Innovations for our Future*. Physica-Verlag, Heidelberg, Germany.
53. Georghiou L (2001) Third Generation Foresight–Integrating the Socio-economic Dimension. *Proc. Int. Conf. on Technology Foresight*, National Institute of Science and Technology Policy (NISTEP), Japan [www.nistep.go.jp/archiev/ftx/eng/mat077e/html/mat0771e.html](http://www.nistep.go.jp/archiev/ftx/eng/mat077e/html/mat0771e.html)
54. Borup M (2005) Sustainability requirements for foresight–A suggestion of a framework of principles. *Int. Conf.: Foresight Management in Corporations and Public Organisations – New Visions for Sustainability*, Helsinki [www.risoe.dk/rispubl/SYS/syspdf/sys\\_2005.pdf](http://www.risoe.dk/rispubl/SYS/syspdf/sys_2005.pdf)
55. Sloman A (1978) *The Computer Revolution in Philosophy: Philosophy Science and Models of Mind*, The Harvester Press, UK.
56. Sellen AJ, Harper RHR (2002) *The myth of the paperless office*. MIT Press, MA.
57. Riley P (2001) E-mail's Contribution to Total Paper Consumption on the U.C. Berkley Campus: An Investigation of the Printing Behavior of both Students and Staff [www.socrates.berkley.edu/~es196/projects/2001final/Riley.pdf](http://www.socrates.berkley.edu/~es196/projects/2001final/Riley.pdf)

58. Blumentritt R, Johnson R (1999) Towards a Strategy for Knowledge Management. *Technology Analysis and Strategic Management*, **11**(3):287–300.
59. Rowland F (1999) Diffusion of information across the sciences. *Communicating Science: Professional Contexts* (Eds. Scanlan E *et al.*), Routledge:155
60. Davenport TH, Prusak L (1998) *Working Knowledge: How Organisations Manage What They Know*. Harvard Business School Press:88–106  
[www.nwlink.com/~donclark/knowledge/vv.html](http://www.nwlink.com/~donclark/knowledge/vv.html)
61. Whittaker S, Sidner C (1996) Email overload: exploring personal information management of email. *Proc. Conf. on Computer Human Interaction*, ACM Press, NY:276–283
62. Quah DT (1999) The Weightless Economy in Growth. *The Business Economist*, **30**(1):40–53
63. Huws U (1999) Material World: the Myth of the ‘Weightless Economy’. *Socialist Register*, Merlin Press/Monthly Review Press
64. Fuchs C (2008) The implications of new information and communication technologies for sustainability. *J. of Environment, Development and Sustainability*, **10**(3):291–309.
65. Munn A *et al.* (2007) *Computer Industry Impacts on the Environment and Society*. University of Michigan, [sitemaker.umich.edu/section002group3/home](http://sitemaker.umich.edu/section002group3/home)
66. Iliasov A (2008) Towards Rigorous Engineering of Resilient Pervasive Systems. 7th European Dependable Computing Conf. (EDCC-7), Kaunas
67. Koomey JG (2007) Estimating Total Power Consumption by Servers in the U.S. and the World. Stanford University/Lawrence Berkeley National Laboratory  
[blogs.business2.com/greenwombat/files/serverpowerusecomplete-v3.pdf](http://blogs.business2.com/greenwombat/files/serverpowerusecomplete-v3.pdf)
68. Patel CD (2003) A Vision of Energy Aware Computing from Chips to Data Centers. *Int. Symposium on Micro-Mechanical Engineering (JSME)*, December
69. Princen T *et al.* (Eds.) (2002) *Confronting Consumption*, MIT Press:4.
70. O’Brien M (2007) *A Crisis of Waste? Understanding the Rubbish Society*. Routledge
71. Cooper T (2007) Challenging the ‘refuse revolution’: war, waste and the rediscovery of recycling, 1900-50. *Historical Research*, Blackwell
72. Waste online (2004) History of waste and recycling information sheet  
[www.wasteonline.org.uk/resources/InformationSheets/HistoryofWaste.htm](http://www.wasteonline.org.uk/resources/InformationSheets/HistoryofWaste.htm)
73. Fisk G (1973) Criteria for a Theory of Responsible Consumption. *J. of Marketing*, **37**:24–31, [www.jstor.org/pss/1250047](http://www.jstor.org/pss/1250047)
74. Murphy J (Ed.) (2007) *Governing Technology for Sustainability*, Earthscan, London.
75. Spangenberg JH (2004) The Society, its products and the environmental role of consumption. *The Ecological Economics of Consumption* (Eds. Reisch LA, Röpke I), Edward Elgar:32–59
76. Faninger G (2003) Towards sustainable development in Austria: renewable energy contributions. *Mitigation and Adaption Strategies for Global Change*, **8**(2):177–188
77. BMVIT (2008) *Technologies for Sustainable Development*, Federal Ministry for Transport, Innovation and Technology, Vienna [www.bmvit.gv.at/en/innovation/sustainable.html](http://www.bmvit.gv.at/en/innovation/sustainable.html)
78. Slade G (2006) *Make a Break: Technology and Obsolescence in America*. Harvard University Press.
79. Ehrenfeld D (1999) The Coming Collapse of the Age of Technology, *Tikkun* (A Bimonthly Jewish Critique of Politics, Culture & Society), Jan/Feb  
[www.tikkun.org/magazine/index.cfm/action/tikkun/issue/tik9901/article/990111a.html](http://www.tikkun.org/magazine/index.cfm/action/tikkun/issue/tik9901/article/990111a.html)
80. Josias C *et al.* (2004) Component Obsolescence Risk Assessment. *Proc. of the 2004 Industrial Engineering Research Conference (IERC)*, Houston  
[www.enme.umd.edu/ESCML/ObsSGER/IERC2004-Josias-Terpenny-McLean-376.pdf](http://www.enme.umd.edu/ESCML/ObsSGER/IERC2004-Josias-Terpenny-McLean-376.pdf)
81. Burns B (2003) Improved Sustainable Product Life Options for Innovation through the re-evaluation of factors affecting Product Obsolescence. *Sustainable Innovation 03*, 8th Int. Conf. Towards Sustainable Product Design (CfSD), Stockholm
82. Feldman K, Sandborn P (2007) Integrating Technology Obsolescence Considerations into Product Design Planning. *Proc. of the ASME 2007 Int. Design Engineering Technical*

- Confs. & Computers and Information in Engineering Conf., Las Vegas  
[www.enme.umd.edu/ESCML/Papers/DFMLC-35881\\_Final\\_Manuscript.pdf](http://www.enme.umd.edu/ESCML/Papers/DFMLC-35881_Final_Manuscript.pdf)
83. Birchall D, Tovstiga G (2002) Future Proofing, Capstone
  84. Birch S (2005) Volvo 3CC is future-proofed. *Automotive Int.*, **113**(4):34.
  85. Birchall D, Tovstiga G (2005) Capabilities for Strategic Advantage: Leading Through Technological Innovation. Palgrave Macmillan:121–127
  86. Petrick IJ, Echols AE (2005) Technology roadmapping in review: A tool for making sustainable new product development decisions. *Technological Forecasting and Social Change*, **71**(1-2):81–100
  87. Farrukh C *et al.* (2003) Technology roadmapping: linking technology resources into business planning. *Int. J. of Technology Management*, **26**(1):2–19
  88. Witt U (2001) Consumption, demand, and economic growth – an introduction. *Escaping Satiation: The Demand Side of Economic Growth* (Ed Witt U), Springer Verlag:1–12
  89. Kash DE, Rycroft, R (2002) Emerging Patterns of Technological Innovation, *Technological Forecasting and Social Change*, **69**(6), July, 581–606
  90. Kash DE, Rycroft RW (2003) To Manage Complex Innovation, Ask the Right Questions. *Research-Technology Management*, **46**(5):29–33
  91. Hobday M (1998) Product complexity, innovation and industrial organisation. *Research Policy*, **26**(6):689–710
  92. Prencipe A (2000) Breadth and depth of technological capabilities in CoPS: The case of the aircraft engine control system. *Research Policy*, **29**(7-8): 895–911
  93. Vries MJ (2005) Ethics and the complexity of technology: a design approach. *Int. Symp. Assoc. for Reformational Philosophy in the Netherlands, Workshop Session III*
  94. Loureiro G *et al.* (Eds.) (2007) *Complex Systems Concurrent Engineering: Collaboration, Technology Innovation and Sustainability*, Springer Verlag, Germany.
  95. Hofer AP, Halman JIM (2004) Complex products and systems: Potential from using layout platforms. *Artificial Intelligence for Engineering Design, Analysis and Manufacturing*, **18**(1):55–69
  96. Lee BC (2007) *Flattening the World Efficiently: Digital Sustainability for the 21st Century*. St. Gallen Symposium: The Power of Natural Resources
  97. Parker R (2008) New Phenon CPU's Announced from AMD. *Techwatch*, 28 March
  98. Ayres D (2008) Reducing Design Complexity at Lucent. *Design News for Mechanical and Design Engineers*, Reed Business Information
  99. PTC White Paper 3453 (2008) Reducing Complexity: Synchronizing Software & Hardware Development. Parametric Technology Corporation, MA  
[www.ptc.com/WCMS/files/72260/en/3453\\_Red\\_Comple\\_WP\\_Final.pdf](http://www.ptc.com/WCMS/files/72260/en/3453_Red_Comple_WP_Final.pdf)
  100. Ashby MF (2005) Eco-selection: environmentally informed material choice, *IMEchE Seminar Proc.: Materials for a Greener Environment – Reduce, Reuse, Recycle and Recover*, London
  101. Ford (2008) Design for Sustainability: Choosing More Sustainable Materials, Sustainability Report 2007/8, [www.ford.com/microsites/sustainability-report-2007-08](http://www.ford.com/microsites/sustainability-report-2007-08)
  102. Rebitzer G *et al.* (2006) Design for the Environment in the Automotive Sector with the Material Selection Tool euroMat  
[www.euromat-online.de/englisch/Unterseiten-engl/method.html](http://www.euromat-online.de/englisch/Unterseiten-engl/method.html)
  103. Wolf O (2005) Techno-economic Feasibility of Large-scale Production of Bio-based Polymers in Europe. Technical Report EUR 22103 EN, European Commission, December
  104. Clark JH, Hardy JJE (2004) Towards Sustainable Chemical Manufacturing: Polylactic Acid – A sustainable polymer? *Sustainable Development in Practice: Case Studies for Engineers and Scientists* (Eds. Azapagic A *et al.*), Wiley:259
  105. Goodship V (2007) *Introduction to Plastics Recycling* (2nd Edition), Smithers Rapra
  106. Thiriez A, Gutowski T (2006) An Environmental Analysis of Injection Molding. *Proc. of the 2006 IEEE Int. Symp. on Electronics and the Environment*:195–200

107. Fisher MM *et al.* (2005) Energy Recovery in the Sustainable Recycling of Plastics from End-of-Life Electrical and Electronic Products. IEEE Int. Symp. on Electronics & the Environment, New Orleans
108. Hunt RG *et al.* (1992) Resource and environmental profile analysis: A life cycle environmental assessment for products and procedures. Environmental Impact Assessment Review, **12** (3):245–269.
109. Lundquist L *et al.* (2000) Life Cycle Engineering of Plastics: Technology, Economy and the Environment, Elsevier
110. O'Neill TJ (2002) Life Cycle Assessment and Environmental Impact of Polymeric Products. Rapra Review Reports **13**(12), Smithers Rapra Technology Ltd.
111. Azapagic A *et al.* (2003) Polymers, the Environment and Sustainable Development, Wiley
112. Tucker N, Johnson M (2004) Low Environmental Impact Polymers, ChemTec Publishing, Canada.
113. Bastioli C (2005) Handbook of Biodegradable Polymers, ChemTec Publishing, Canada.
114. Delaplace M, Kabouya H (2001) Some considerations about interactions between regulation and technological innovation: the case of a sustainable technology, biodegradable materials in Germany, European J. of Innovation Management, **4**(4):181
115. Carlsson B *et al.* (2002) Innovation systems: analytical and Methodological issues. Research Policy, **31**(2):235
116. Nakiri T *et al.* (2007) Development of Electrical Wire Using Biodegradable Polymer. IEEE Trans. on Industrial Applications, **43**(4):1069–1074
117. Rosato D (2008) Novel Bioplastic Consumer Product Developments. Omnexus, [www.omnexus.com/plastic-channels/green-bio-plastics/editorials.aspx?id=18461](http://www.omnexus.com/plastic-channels/green-bio-plastics/editorials.aspx?id=18461)
118. Okada K *et al.* (2003) Properties and particles dispersion of biodegradable resin/clay nanocomposites, Korea-Australia Rheological Journal, **15**(1):43–50
119. Ieko Y (2006) Nano clay reinforced biodegradable plastics of PCL starch blends. Polymers for Advanced Technologies, **17**(11-12):940–944
120. Greiner Environmental (2002) Environmental, Health and Safety Issues in the Coated Wire and Cable Industry (Technical Report No. 51), Toxic Use Reduction Institute, University of Massachusetts Lowell, [turi.org/content/download/913/4501/file/Wire\\_Cable\\_TechReport.pdf](http://turi.org/content/download/913/4501/file/Wire_Cable_TechReport.pdf)
121. Leung AOW (2008) Heavy Metals Concentrations of Surface Dust from e-Waste Recycling and Its Human Health Implications in Southeast China, Environmental Science & Technology, American Chemical Society, **42**(7):2674–2680.
122. European Union (2002) Directive of the European Parliament on the Restriction of the Use of Certain Hazardous Substances (2002/95/EC) [eu.int/comm/environment/docum/00347\\_en.htm](http://eu.int/comm/environment/docum/00347_en.htm)
123. European Union (2002) Directive on Waste Electrical and Electronic Equipment (2002/96/EC), [ec.europa.eu/environment/waste/weee/index\\_en.htm](http://ec.europa.eu/environment/waste/weee/index_en.htm)
124. Puttlitz KJ, Stalter KA (Eds.) (2004) Handbook of Lead-Free Solder Technology for Microelectronic Assemblies, Marcel Dekker
125. Dittes M *et al.* (2003) Tin Whisker Formation – Results, Test Methods and Countermeasures, 53rd IEEE Electronic Components and Technology Conf.: 822–826
126. Galyon GT, Gedney R (2004) Avoiding Tin Whisker Reliability Problems, Circuits Assembly, August:26–31
127. Weaver PM, Rotmans J (2006) Integrating Sustainability Assessment: What? Why? How? Matisse Working Paper 1, [matisse-project.net/projectcomm/uploads/tx\\_article/Working\\_Paper\\_1\\_03.pdf](http://matisse-project.net/projectcomm/uploads/tx_article/Working_Paper_1_03.pdf)
128. Ritthoff M *et al.* (2002) Calculating MIPS: resource productivity of products and services, Wuppertal Spezial 27e, Wuppertal Institute for Climate, Environment and Energy, Wuppertal
129. Schmidt-Bleek F (2004) No Sustainability without Dematerialisation, (Part based text for) 2004 Report of the Future Council of the German State of North Rhine-Westfalia

130. Von Weizsäcker EU (1998) Dematerialisation. Managing a Material world: Perspectives in Industrial Ecology (Eds. Vellinga P *et al.*), Kluwer:45–54
131. Williams ED *et al.* (2002) The 1.7 Kilogram Microchip: Energy and Material Use in the Production of Semiconductor Devices, Environmental Science & Technology. American Chemical Society, **36**(12):5504–5510
132. Environmental Literacy Council (2008) Computer Chip Life Cycle, 3 April, [enviroliteracy.org/article.php/1275.html](http://enviroliteracy.org/article.php/1275.html)
133. Teece DJ (1986) Profiting from technological innovation: implications for integration, collaboration, licensing and public policy. *Research Policy*, **15**(6), 285–305
134. Worden K. *et al.* (2003) Smart Technologies. World Scientific Publishing, Singapore.
135. Spencer Jr BF *et al.* (Eds.) (2007) World Forum on Smart Materials and Smart Structures Technology: Proc. of SMSST'07, Routledge
136. Schwartz M (2008) Smart Materials. CRC Press, Boca Raton, FL. (Forthcoming)
137. Tähemaa T, Reedik V (2001) Prognosis of the Competitive Dependability of Mechatronic Products. Design Methods for Performance and Sustainability (WDK 28) (Eds. Culley S *et al.*), Proc. of 13th Int. Conf. on Engineering Design, Professional Engineering Publishing:3–10
138. Giudice F *et al.* (2006) Product Design for the Environment. CRC Press, Boca Raton: 251–276
139. Baynes A *et al.* (2001) Environmental Technologies and their Business Drivers. Sustainable Solutions: Developing Products and Services for the Future (Eds Charter M, Tischner U), Greenleaf Publications:340–348
140. Overby CM (1980) Product Design for a Sustainable Future: A Matter of Ethics? American Society for Engineering Education (ASEE) Annual Conf. Proc.:511–519 [www.article9society.org/pp-14.pdf](http://www.article9society.org/pp-14.pdf)
141. Stahl BC (2000) Responsibility for Technological Development by Discourse. [www.cse.dmu.ac.uk/~bstahl/publications/2000\\_Resp\\_tech\\_dev.pdf](http://www.cse.dmu.ac.uk/~bstahl/publications/2000_Resp_tech_dev.pdf)
142. Grunwald A (2001) The application of ethics to engineering and the engineer's moral responsibility: Perspectives for a research agenda. *Science and Engineering Ethics*, **7**(3):415–428
143. Alpern KD (1983) Moral Responsibility for Engineers, Business and Professional Ethics Journal, **2**:39–48
144. Abraham MA (2005) Principles of Sustainable Engineering. Sustainability Science and Engineering: Defining Principles (Ed Abrahams MA), Elsevier Science:3–10
145. EcoDesign (2005) A Guide for EcoDesign Tools. 2nd Edition, August, [www.ecodesignarc.info/servlet/is/413/](http://www.ecodesignarc.info/servlet/is/413/)
146. Kurk F, McNamara C (2006) Better by Design – An Innovation Guide: Using Design Solutions, Minnesota Pollution Control Agency, St. Paul [www.engineeringpathway.com/ep/k12/BetterByDesign\\_2006.pdf](http://www.engineeringpathway.com/ep/k12/BetterByDesign_2006.pdf)
147. Allwood JM (2005) Distributed localised production as a strategy for sustainable manufacturing. 4th Int. Conf. on Design and Manufacturing for Sustainable Development, Newcastle
148. Baeyens J (2005) Challenges for Design Engineers in Sustainable Engineering. 5th Int. Conf. on Design and Manufacture for Sustainable Development, Loughborough
149. Tischner U, Charter M (2001) Sustainable Product Design. Sustainable Solutions: Developing Products and Services for the Future (Eds. Charter M, Tischner U), Greenleaf Publishing:118–137
150. Brissaud D *et al.* (2006) Innovation in Life Cycle Engineering and Sustainable Development, Springer
151. Bey N, McAloone T (2006) From LCA to PSS – Making leaps towards sustainability by applying product/service-system thinking in product development. Proc. of 13th Int. Conf. on Life Cycle Engineering (LCE 2006), Leuvin:571–576



152. Jelinski LW *et al.* (1992) Industrial Ecology: Concepts and Approaches. Proc. National Academy of Science (Colloquium Paper, NAS, Washington, DC. 20/21 May, 1991), 89, February:793–797
153. Frosch RA, Gallopoulos NE (1989) Strategies for Manufacturing. *Scientific American*, **189**(3):144–152
154. Tibbs H (1993) Industrial Ecology: An Environmental Agenda for Industry, Global Business Network, p.10. [www.hardintibbs.com/pdfs/gbn\\_ecology.pdf](http://www.hardintibbs.com/pdfs/gbn_ecology.pdf)
155. Gehin A *et al.* (2008) A tool to implement sustainable end-of-life strategies in the product development phase. *J. for Cleaner Technology*, **16**(5):566–576
156. Allen DT (2004) An Industrial Ecology: Material Flows and Engineering Design. *Sustainable Development in Practice* (Eds. Azapagic A *et al.*), Wiley
157. Wernick IK *et al.* (1997) Materialization and Dematerialization. *Technological Strategies and the Human Environment* (Eds. Ausubel J, Langford HD), National Academy Press: 135–156
158. Ehrenfeld JR (1997) Industrial Ecology: a framework for product and process design. *J. of Cleaner Production*, **5**(1/2):87–95
159. Berkhout F (2002) Technological regimes, path dependency and the environment. *Global Environmental Change*, **12**(1):1–4
160. Sandén B (2004) Technology Path Assessment for Sustainable Technology Development. *Innovation: Management, Policy & Practice*, 6 (Corporate Sustainability: Governance, Innovation Strategy, Development & Methods):316–330
161. Millbank JH (2001) Strategies for the Effective Management of Technology Transfer. M.Sc., Dissertation, University of Salford, UK:49
162. Rycroft RW, Kash DE (2002) Path Dependence in the Innovation of Complex Technologies. *Technology Analysis & Strategic Management*, **14**(1):28
163. Psaltis D *et al.* (2006) Developing optofluidic technology through the fusion of microfluidics and optics. *Nature (Insight Review)*, 427:381–386.
164. Ko HC *et al.* (2008) A hemispherical electronic eye camera based on compressible silicon optoelectronics. *Nature (Letters)*, 454:748–753
165. Dhillon BS (2007) Design for Reliability. *Environmentally Conscience Mechanical Design* (Ed. Kutz M), Wiley:161–184
166. Okogbaa OG (2007) Design for Maintainability. In:[165].
167. Kara S (2008) Assessment of products for useful life. *CIRP Annals – Manufacturing Technology*, **57**(1):1–4
168. Lambert AJD, Gupta SM (2005) Disassembly Modeling for Assembly, Maintenance, Reuse, and Recycling. CPC Press
169. Seliger G (Ed.) (2007) Sustainability in Manufacturing: Recovery of Resources in Product and Material Cycles, Springer Verlag, Germany.
170. Goggin K, Browne J (2000) Towards a taxonomy of resource recovery for end-of-life products. *Computers in Industry*, **42**(2/3):177–191
171. Yonghua X *et al.* (2008) Role of Resource Recovery of Waste Machinery and Electronic Products in Sustainable Development. *Int. Conf. on Bioinformatics and Biomedical Engineering (ICBBE 2008)*, Shanghai:4333–4335
172. King AM *et al.* (2005) Reducing waste: repair, recondition, remanufacture or recycle? *Sustainable Development*, **14**(4):257–267
173. Nasr N, Thurston M (2006) Remanufacturing: A Key Enabler to Sustainable Product Systems. Proc. of the 13th CIRP International Conference on Life Cycle Engineering, Engineering (LCE 2006), Leuvin:15–18
174. Steinhilper R *et al.* (2006) Product and Process Assessment for Remanufacturing of Computer Controlled Automotive Components. In: [169]
175. Ijomah WL *et al.* (2007) Development of robust design-for-remanufacturing guidelines to further the aims for sustainable development. *Int. J. of Production Research*, **45**(18/19):4513–4536

176. Carmichael C (2003) A Primer on Sustainable Technology and Development. ISTD, Georgia Institute of Technology, [www.sustainable.gatech.edu/resources/ISTDPrimer\\_1\\_7\\_02.pdf](http://www.sustainable.gatech.edu/resources/ISTDPrimer_1_7_02.pdf)
177. Ljungberg LY (2007) Materials selection and design for development of sustainable products. *Materials & Design*, **28**(2):466–479
178. Foxon TJ (2006) Applying systems thinking and practice for promoting sustainable innovation. (Science Policy Research Unit) SPRU 40th Anniversary Conf. University of Sussex
179. Lehmann-Waffenschmidt M (Ed.) (2007) *Innovations Towards Sustainability: Conditions and Consequences*, Physica-Verlag, Heidelberg.
180. Hines F, Marin O (2004) Building innovations for sustainability: 11th Int. Conf. of the Greening of the Industry Network (Editorial), *Business Strategy and the Environment*, **13**(4):201–208
181. Halls S (2006) Technology transfer and uptake of environmentally sound technologies. *The Int. Handbook on Environmental Technology Management* (Eds. Marinova D *et al.*), Edward Elgar Publishing:175

# Chapter 3

## The “Revolution”: a Small Company Revived

David Dawson<sup>1</sup>

### 3.1 Some History of the UK Industry-Academic Link, the “KTP”

In the late 1970s, there was a recognition in the UK that there needed to be closer links forged between industry and academia to foster innovation in companies and improve the relevance of teaching in academia and thereby enhance the motivation of students. Using a somewhat flawed analogy, the resulting concept was that of a “Teaching Company”, in effect a response to the query, “if doctors can be trained in a *teaching hospital*, why can’t engineers be trained in a *teaching company*?” A moment’s thought around matters of urgent necessity and economics soon highlighted the limitations of the analogy! However, enough of the concept remained for the then Department of Trade & Industry (DTI) in the UK to begin to facilitate with increasingly substantial funding a system for industry-academic collaboration which has proved successful for more than three decades.

In essence, the concept works in this manner:

- A company recognises a need to innovate in an area in which it lacks expertise.
- An academic institution is found which has the requisite expertise within specific individuals at faculty level.
- The two or more partners are brought together with assistance from a UK government<sup>2</sup> funded consultant and a detailed project proposal is made.
- On approval, the university and company jointly seek, on the world market if necessary, a mature graduate (typically age 25 to 30).
- The graduate is appointed on a two year contract with the university, but works on the company site under the joint supervision of the nominated academic and a person at the company, usually at board level.

---

<sup>1</sup> Consultant, UK

<sup>2</sup> This was at the time of the project being reported through the Department of Trade and Industry, since split into the Department for Business, Enterprise and Regulatory Reform and the Department for Innovation, Universities and Skills.

- The UK government typically funds around 50% of the total costs and the company funds the balance.
- On a successful completion of the project, the usual expectation is that the graduate will be taken on to the company payroll.

The arrangements used to be known as “Teaching Company Schemes”, later “TCS”, and are now under the official title of “Knowledge Transfer Partnerships” or KTP [1]<sup>3</sup>. These now operate on a very large scale with many hundreds of such links operating in the UK at any one time. This case study describes an outstanding example which attracted the premier award for such a link in the UK in 2002.

### **3.2 Some Observations on the Acceptance of Computer-aided Engineering (CAE) in Smaller Companies**

Towards the close of the second millennium, the larger proportion of expenditure on CAEware both hard and soft would have been found in industries such as aerospace, automotive and process plant contractors. Smaller companies manufacturing specialist products such as agricultural machinery, bread making machines or refuse vehicles were sometimes headed by senior managers and directors who viewed CAE as being for the “big companies” and costly in requiring sophisticated workstations and expensive and “difficult” software. Many will have invested in 2-CAD, but some would have insufficient appreciation of the benefits afforded by 3D, not just in the design stage, but in almost every area of the downstream business activity.

It has been said that:

Mechanical engineers think in terms of physical forms and motion,  
 electrical engineers think in terms of signals and circuits, and  
 software engineers think in terms of logic and syntax.

The perfect mechatronic engineer would of course be highly and equally competent across the psychological and technical profile! The fact is, however, that at the concept definition stage of a new product or system, such as a radically new domestic food mixer, it will often be the mechanical conceptual design (not disregarding industrial design and styling) which will predominate in the early stages. Often, it is with constructional toys and “taking things to bits” that spatial awareness is developed and embedded in childhood. Hence, those who eventually choose an educational path and career in mechanical engineering design and maybe henceforward in mechatronics, usually have no difficulty in imagining solid objects, mentally rotating and “viewing” them and observing the motion of

---

<sup>3</sup> The above presents the broad outline of the scheme. The precise structure and details have varied over the years the Teaching Company Programmes/Knowledge Transfer Partnerships have been operating.

even complex mechanisms. Therefore, the mechanical-mechatronic engineer needs software tools which enable “3D-thinking” to be seamlessly transferred on to the screen by creating and capturing in software the requisite geometry. Relatively inexpensive software such as SolidWorks® [2] and Inventor® [3] running on standard office PCs have now transformed the whole process of product innovation in smaller companies. No longer is it acceptable to draw parts in stand-alone 2D and modify ill fitting assemblies on the shop floor. Even so, in some companies with influential non-technical boards, a fear of innovation has been akin to a death-wish.

This case study shows how a small engineering company in the Lake District in the UK did, in fact, achieve a revival, indeed a “Revolution”, through 3D-CAE applied through the means of a Knowledge Transfer Partnership. Once the geometry of a product is established, so much else can follow with the accurate and less onerous transfer of data into essential downstream business areas as Figure 3.1 shows.

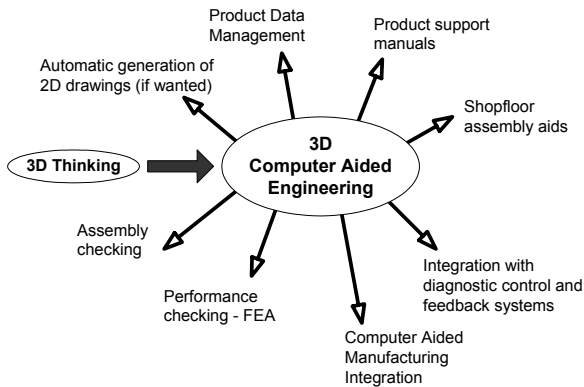

Fig. 3.1 3D-CAE and business integration

### 3.3 The Ducker Engineering Case Study

#### 3.3.1 Problem or Opportunity?

This story shows how a business success was brought about for a small company, Ducker Engineering, which is now incorporated as a division of Kannegiesser, the leading international company in the field of industrial laundry equipment and textile product work movement systems [4].

Some mechatronic purists may object and allege that the product to be described does not fulfil the idealistic definition of an intelligent system with highly sophisticated sensors and software such as an autonomous puddle-avoiding unicycle able to navigate its way home after the human rider has been taken off by

ambulance for personal repair! However, as a complex but integrated electro-mechanical system with many sensors, drives and actuators, it is in good company with many industrial products and systems controlled by programmable logic controllers (PLCs) and common motor control algorithms. Much published material already describes such systems as “mechatronic” without inhibition.

At the time the project was initiated, Ducker Engineering Ltd. was a privately owned company based in Kendal in the UK, and was well established in the field of designing, building and supplying equipment such as garment folding machines and heated tunnels like that of Figure 3.2 for drying and conditioning garments after washing. Clients were major industrial laundries, themselves having contracts with clients such as hospitals and supermarkets with large numbers of uniforms, overalls and suchlike garments to be processed.

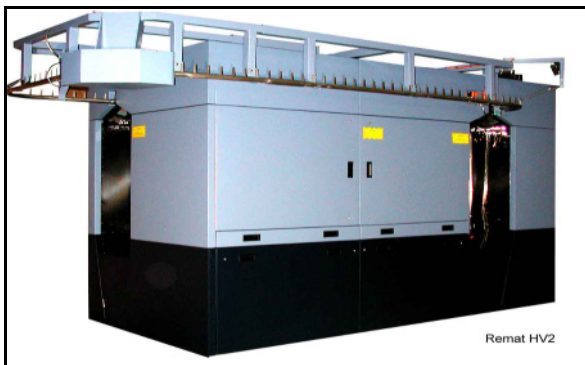

**Fig. 3.2** Garment conditioning tunnel

In 1999, however, the business position of the company was becoming fragile, with a declining turnover due to adverse currency exchange rates and increasing competition in the markets for their traditional products. Future profitability was in doubt. There was further vulnerability in the company’s knowledge base due to the retirement of a senior mechanical design engineer. Significant strengths remained in place, however, with a very experienced and effective small team in industrial drives and controls, and a skilled and well motivated shop floor assembly staff. The company CEO was highly knowledgeable in the company’s market areas, was alert to changes and developments, was not risk-averse and was willing to invest as necessary to improve the company’s position, and therefore was able concurrently to identify a new market opportunity for the company and the means of realising it.

All over the world in washrooms and restrooms in companies, supermarkets, hospitals, cafes and many other places, the hot-air hand drier is ubiquitous. However, these machines are noisy and there was an emerging view supported by some academic research that they could distribute pathogens by blowing them around the local environment. Two common alternatives presented themselves, the paper towel magazine-type dispenser resulting in mess and inconvenience and the traditional roller towel cabinet of Figure 3.3.



**Fig. 3.3** A typical towel cabinet

Of the three common methods of hand drying, the cabinet-type dispenser is therefore experiencing a resurgence. The towels are typically 40 m in length and when a soiled towel has run through, it remains in the cabinet as a tight roll for collection by the hygiene service provider and onward despatch to an industrial laundry. One washing method is simply to unroll and flake the towel and tie it in a bundle to be washed in a drum-type batch washer. This is clearly not very satisfactory in cleansing the inner parts of the bundle.

A proven alternative was a machine whose manufacture in the UK ceased over 25 years prior to the time of writing in 2008. This was based on a continuous process of unrolling, washing, rinsing, drying and re-rolling the towels. These machines incorporated a buffer for the reception of the towel as it was unrolled and flaked at the beginning of the process in such a way that the operative could, in a matter of seconds, use a simple hand-held sewing machine to stitch the soon-to-depart edge of the in-process towel to the leading edge of the next. A simple hook tool was used to remove the stitching from the then trailing edge of the rolled up processed towel and so on.

Fortunately, the requisite special process expertise was still accessible in the form of a retired engineer from the original machine company who had developed a successful second career in manufacturing bespoke parts for the significant working population of old machines and in travelling widely around Europe to maintain them. Such rare and valued expertise needs to be captured and exploited for the future, perhaps a lesson for many small companies. As can be seen in Figure 3.4, the tool boxes suggest frequent stoppages and breakdowns. Poor wash performance, excessive use of detergent (and high environmental impact), unappealing ergonomics and some health and safety issues all pointed to the need for a radically new approach if the essentially proven process principles were to be available to the industrial laundry market for much longer.

It was through this contact with the retired engineer that the CEO of Ducker Engineering was able to see a way to diversify and extend the product range and at the same time enhance the design company's processes and operations. The CEO then approached the Engineering Department at Lancaster University in the UK, located some 30km from Kendal where there was a strong tradition of engineering design and academic-industrial interaction. The chosen mechanism for developing

collaboration was through the KTP link, as described in Section 3.1. The project objectives were defined as:

To design, develop and launch a major product diversification programme, using the opportunities for Computer Aided Engineering (CAE) Applications and Integration to transform the whole business.

The search was then on to find the key player, the young but experienced engineering graduate who would be the principal agent of this transformation. Eventually, a graduate of a Computer Aided Engineering (CAE) undergraduate programme with 15 months experience in design & development with Parker Hannifin was appointed and proved to be the right person for the task. Among the software packages included in the undergraduate programme, SolidWorks® [2] was considered to be particularly suitable for the task ahead. After dealing with and overcoming blockages from the UK Immigration Service, a work permit was obtained (1999) for this non-UK national and they were able to start work, showing almost immediate acceptance in dealing with the shop floor culture of a small UK provincial company. This was helped in large part by their remarkable ability to pick up and employ to good effect the full range of English idiomatic language! At the time of writing in mid-2008, the individual concerned is a member of the Institution of Mechanical Engineers, a UK Citizen and an independent consultant in CAE with their own developed software for product data management, RevZone [4].



**Fig. 3.4** An “Old Machine” environment



The project was intended to last for two years, and thus started with a senior faculty member from Lancaster University<sup>4</sup> and Ducker Engineering’s managing director acting jointly as supervisors for the engineering graduate, who worked closely with the in-house electrical team and enjoyed frequent consultation with the process expert. No detail design information was available for the original machines, so a decision was taken to start with a “clean screen” retaining only the general operating principles, modified and improved as judged necessary. None of the original parts were re-used.

### 3.3.2 *The “Revolution”*

The above choice of name encapsulates not only the greatly improved performance of the new machine by comparison with the old, but also the radical effect upon the company’s business model. It had been generally acknowledged within the company that a machine of this complexity would historically have required at least 18 months or longer to progress from concept to a working prototype. The first machine was designed, the parts were sourced and manufactured, and the machine was assembled, tested, shipped and working within a commercial laundry within eight months. The customer satisfaction, awareness and expressions of intent that this achievement demonstrated convinced Ducker Engineering that, indeed, here was a significant market opportunity. Accordingly, further machines were authorised to be built and three of these are shown in Figure 3.5.

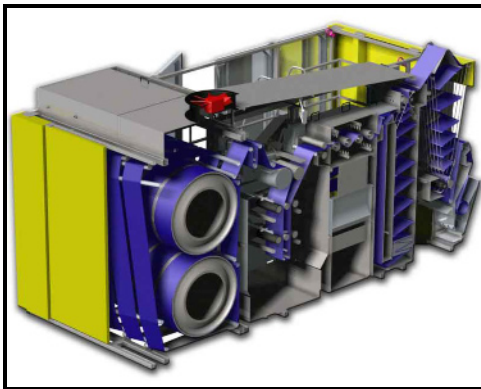

**Fig. 3.5** New machines in final assembly

---

<sup>4</sup> David Dawson, the author of this chapter

The power of CAE in areas such as information for marketing and customer support was shown when a potential client visiting the company asked if it would be possible to have some diagrams of the complex path of the towel through the machine. Clearly expecting that it could be days or even weeks before such a diagram, perhaps even a traditional 2D drawing, would be provided, they were astonished and gratified to receive during their visit the isometric vertical slice as shown in Figure 3.6.



**Fig. 3.6** “Revolution” sectional view

**Table 3.1** “Revolution” performance comparison

<b>Performance Criteria</b>	<b>Target</b>	<b>Achieved</b>
Machine Cycle Speed (km/hr)	3.6	4.2
Operator Output (towels/hr)	70	100+
Water Usage (litres/towel kg)	3	1.5
Total Processing Cost (UKpence/towel)	33	19
Concept to Prototype (years)	1.5	0.75

It is, of course, entirely feasible for such a diagram to have been generated for potential clients well ahead of committing to “cut metal”. The prototype machine was a complex assembly with multiple shafts and bearings, tanks and pumping systems and two steam heated drier drums around which the towel passes in multiple spiral laps on its way to the output buffer and re-winder. Within this, there are numerous control loops for water level and temperature, pumps and sprays, motor speeds and torque, web tension and breakage detection. In service, the machine demonstrated the extent of the improvement of performance compared to the design target based on the very best of the old machines then-current performance, as can be seen from Table 3.1. The advantage over the other competing forms of wash process was even more significant as shown in Figure 3.7.

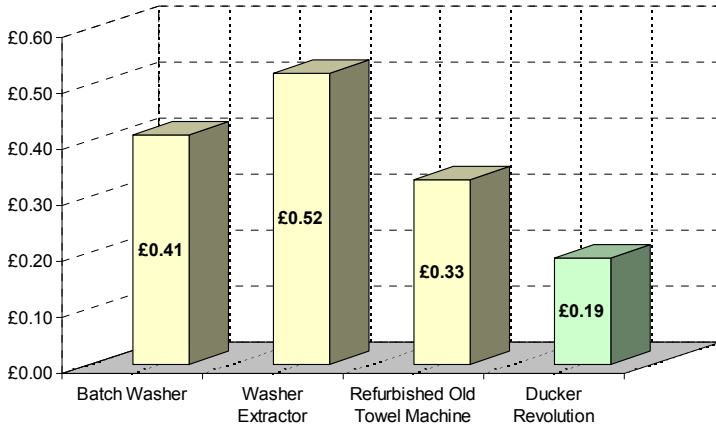

Fig. 3.7 Comparison of process costs per towel

### 3.3.3 Further Benefits Demonstrated in the CAE Application

In a job-shop or batch manufacturing shop floor environment where the predominant activity is the assembly of complex machines from largely bought-in components as subassemblies, the provision of assembly aids can help to avoid misidentification and achieve “right first time”. On the Ducker Engineering shop floor, large numbers of laminated sheets showing exploded views of renditions of important assemblies were hung on easily accessible display frames for consultation by the fitters. Two examples of these are shown in Figure 3.8.

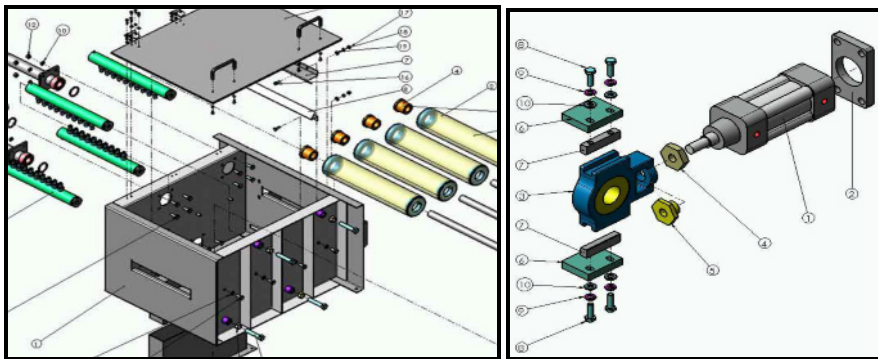
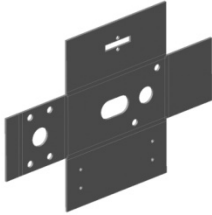

Fig. 3.8 Guide sheets for assemblies

Such assemblies often include subassemblies bolted to casings made of folded sheet metal. In such assemblies, the sheet conventionally has all the requisite holes and apertures punched out on the flat as in Figure 3.9. It is evidently necessary that when the sides are folded up to form a box, the opposing location holes are

aligned to an acceptable tolerance. Software modules can directly link the basic geometry within the primary CAE package into programmes which calculate the position for holes to be punched in the flat, taking into account the effect of bend radius, elastic spring back for defined materials and other significant criteria. If suppliers can be persuaded to adopt the necessary software for their cutter-punch machines, then easy data transfer is achieved and errors can be avoided.



**Fig. 3.9** Component in the flat

Further benefits are obtained with links to Finite Element Analysis modules for the checking of parts which may be critical in terms of stress. Here, the *proviso* must always be that the load cases are correctly defined. Otherwise, the results become useless and even dangerously misleading. In this project, COSMOSWorks® [6] was used to good effect. The montage of Figure 3.10 shows some important subassemblies with parts extracted for display.

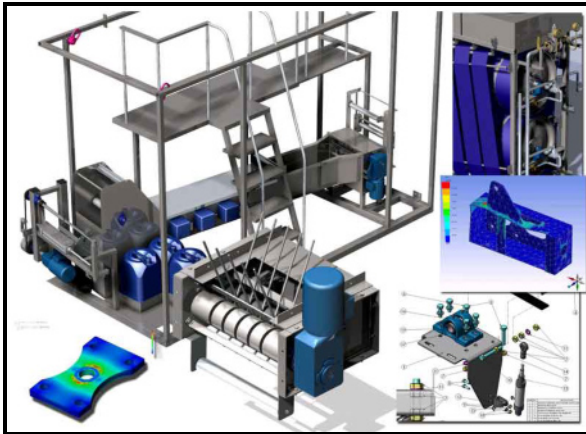

**Fig. 3.10** FEA display montage

The design of the operator interface was a particularly important part of the “Revolution” concept and specification. Such machines tend to be operated by unskilled employees who work under time pressures and who have neither the opportunity nor the technical ability to carry out fault finding and troubleshooting. However, they must carry out routine tasks such as the topping up of the detergent. To aid the operators’ task, a robust touch screen was designed and incorporated at the work station as shown in Figure 3.11. Here, a system of “flags”

is employed in the display. These are normally ticks on a green background but turn to crosses on a red background when a fault occurs or attention is required at a corresponding location. These are linked to error/action messages which then display advice or the required action.

The machines also have a self-reporting capability linked directly to the manufacturer for both engineering and commercial purposes so that help could be given on technical questions, supplies and utilities consumption.

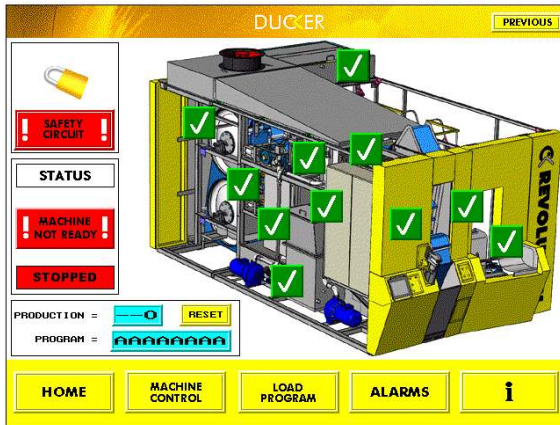

Fig. 3.11 Operator interface

### 3.4 Conclusions

Within a few months of the conclusion of the 2 year project, a complete turnaround had been achieved by the company:

- a new world-wide market with export turnover doubled;
- product development time halved;
- a completely new product under consideration;
- CAE skills disseminated to additional staff;
- reduced manufacturing costs, re-design and manufacturing re-work;
- existing jobs secured and payroll increased by 30%;
- supply chain management improved;
- academic links strengthened;
- profitable operation for the first time in 4 years.

The key to this achievement was indubitably the ready acceptance of the company to bring in and implement the full potential available from a capable CAE package, along with the people to apply it. Substantial effects were also felt in the Lancaster University Engineering Department with a parallel installation of SolidWorks® for all design activities, including the morale-boosting participation in the international “Formula Student” race car competition.

In December 2002 at a presentation by Lord Sainsbury, the then Ducker Engineering Limited was given a UK national award for the best link between an academic institution and a small company, and also an “Engineering Excellence Award” by the Royal Academy of Engineering. This transformation in the company thus made it a most attractive proposition for it to become incorporated in 2005 as Kannegiesser UK, a strategic part of the world’s leading manufacturer of industrial laundry equipment who continues to use SolidWorks® and RevZone® in the design, manufacture and assembly of a range of other innovative machines.

## References

1. [www.ktponline.org.uk/](http://www.ktponline.org.uk/)
2. [www.solidworks.com/](http://www.solidworks.com/)
3. <http://usa.autodesk.com/adsk/servlet/index?siteID=123112&id=4246282>
4. [www.kannegiesser.de](http://www.kannegiesser.de)
5. [www.eltonsolutions.com/](http://www.eltonsolutions.com/)
6. [www.solidworks.com/Pages/products/cosmos/cosmosworks.html](http://www.solidworks.com/Pages/products/cosmos/cosmosworks.html)

# Chapter 4

## A Mechatronic Design Process and Its Application

Xiu-Tian Yan and Rémi Zante<sup>1</sup>

### 4.1 Introduction to Mechatronic Design

As with conventional engineering design, mechatronic system design is normally considered to be a sequential process in which a design solution to a given design problem is generated, explored and evaluated following a series of prescribed steps. These relatively prescriptive design structures can be found in traditional design process models as found in many classic design text books such as those by French [1] and Pahl & Beitz [2], and have more recently been placed in a wider mechatronic context by Bradley *et al.* [3] and Bracewell *et al.* [4].

A new mechatronic design process model is proposed and introduced here and is intended to support a holistic view of the mechatronics system or product design by considering functional as well as life-cycle issues during the design phase. The application of the model is then illustrated through its application to the design of a high-precision mechatronic oil dispensing system with a very low flow rate. The associated life-cycle considerations and associated approaches are then as set out in Borg *et al.* [5].

### 4.2 Mechatronic Design Process Model

The proposed mechatronic design process model is based on an enhancement of French's model by introducing stages addressing the design needs of mechatronic systems and products. This model is further enhanced by introducing concurrent engineering design principles and proactive design support concepts using life-cycle mechatronic system knowledge into the model structure. This will then provide a comprehensive model for mechatronic system design, employing modern design methodologies and techniques to enable mechatronic system

---

<sup>1</sup> University of Strathclyde, UK

designers to rapidly produce solutions for a given design problem. The key design stages in this model consists of:

- product market research;
- system conceptual design;
- system embodiment/detailed design.

This latter consisting of three substages:

- i) model construction process;
- ii) component matching and sizing, and virtual system simulation evaluation;
- iii) comparative analysis.

These fully evaluated mechatronic system design solutions can then be prototyped and tested, and manufactured and assembled.

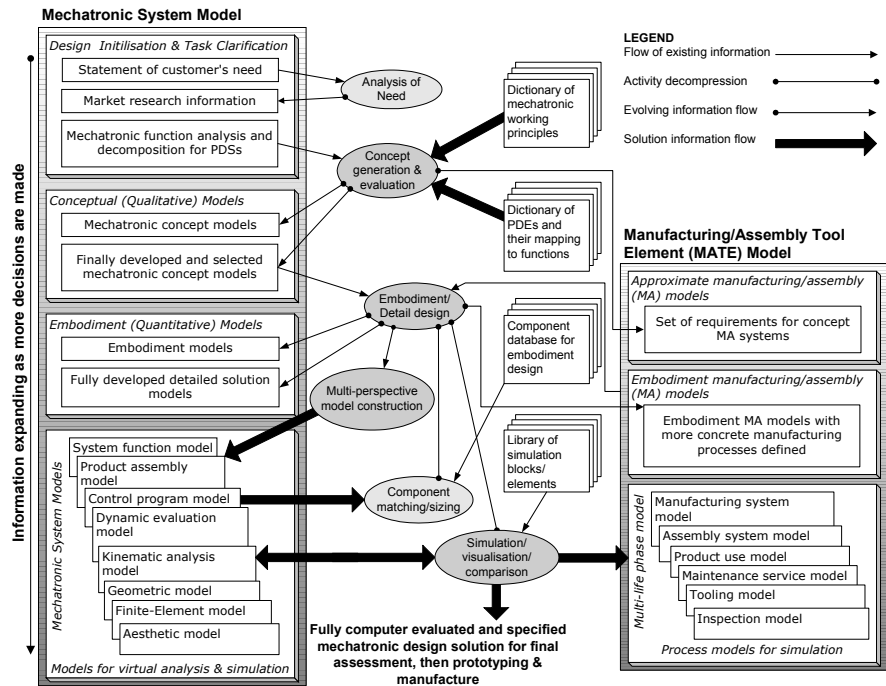

**Fig. 4.1** Concurrent mechatronic system and manufacturing/assembly design process model

In contrast to traditional engineering design approaches, a new concurrent mechatronic system design and manufacturing/assembly design process model is proposed as shown in Figure 4.1. This model is based on the integration of the life-cycle design model [5] and a mechatronic system design model [6] and depicts the use of an ideal computer support design environment for mechatronic



product development. The development of a mechatronic product using such an ideal computer support system goes through the following stages: *design initialisation and task clarification* stage through the analysis of need, *concepts and qualitative modelling* through concept generation, computer based modelling and evaluation, *embodiment and quantitative modelling* taking place at the traditional embodiment/detailed design stage, but characterised here by iterative simulation of mechatronic product performance through the use of several simulation tools and techniques.

These design solutions are further analysed and evaluated from the structural and dynamics points of view by firstly constructing and evaluating finite element analysis (FEA) and dynamic analysis models, and then by evaluating the behaviour of chosen mechatronic design solution using these models. To take an even more holistic design approach using the multi-perspective modelling and simulation approach [7], further evaluation of the mechatronic solutions can be undertaken by investigating the multi-perspective models covering geometry, costs, and so on. Evaluations of design alternatives can also be carried out to facilitate designers in making informed design decisions.

During the above process, mechatronic product definition models are gradually evolving and expanding from the simple models at the initial design stage to a fuller model at the final embodiment/detail design stage. This is due to the fact that during this process, more and more design decisions are made to concretise and quantify design solutions. During this process of generating design solutions, a design evolves from being abstract, qualitative and vague to being detailed, quantitative and concrete. As the design develops, the associated design information expands to a richer level as a result of the increasing number of decisions made and recorded within the design process.

A set of dictionaries, e.g., mechatronic working principles, Product Design Elements and their mapped functions and libraries of past well-proven design modules and proven simulation models of past design solutions, can be reused to assist designers in generating a working solution. These can be in the form of a computer supported design database containing useful and proven partial solutions to mechatronic design problems. Examples of this approach include the Schemebuilder project and *Dymola* software [8], supported by the open language structure *Modelica* [9]. The latter has attracted considerable research and development interest in recent years. The contents of the libraries and dictionaries can also be sought from various sources of textbooks, internet searches and company specific collections of past products.

A modular approach should be adopted and the basic component/product building blocks can be generalised to construct the libraries. Once this set of dictionaries and libraries is compiled, they can be used to support the generation of product models.

The final outcome from the idealised computer support system is a set of multi-perspective mechatronic design models which collectively describe and define the behaviour of a mechatronic system. These models include, among others<sup>2</sup>:

- A model defining the functional behaviour of the intended mechatronic product or system<sup>3</sup>.
- A model defining the control architecture and the associated algorithms for the mechatronic product or system.
- A model containing the geometric information about the mechatronic product or system.
- An assembly model specifying a list of components and their relationships.
- A finite-element analysis model for structural integrity analysis.
- A dynamic behaviour evaluation model if the system dynamics are a major concern.
- A kinematic model to evaluate the motion related system behaviour.
- An aesthetic model for evaluating the visual aspects of the mechatronic product or system.

Each of these models describes a particular view of the mechatronic system within certain levels of accuracy and detail, though collectively, these models fully define the properties of the system in terms of its physical definition, its intentional purpose and life use and disposal. The behaviour of a system in its various anticipated life-cycle environments can also be predicted even if the system only exists as a virtual product in its virtual computer model.

For mechatronic system design, equally important is the concurrent modelling of life-cycle considerations. This is specifically represented by manufacturing /assembly (MA) modelling in the design process model of Figure 4.1. On the right of this figure<sup>4</sup>, an evolving Manufacturing/Assembly Tool Element (MATE) model is represented. This representation is intended to show that concurrent product and MATE modelling can be established from the interaction of component/product models with available MATE knowledge by extracting relevant product information.

For example, knowing that a sheet metal component requires a hole-feature as part of its design decision, a punch-die tooling design can be derived to form a tooling model. This deduction leads to the concurrent development of tooling for the product. It can also be seen that MATE models are also expanding and evolving as more MATE model details can be added with more product design decisions made.

To illustrate the principles and potentials of the above design process model, the case study and associated mechatronic design solution are representative of the approach described. However, the life-cycle considerations of the design problem

---

<sup>2</sup> This is not a comprehensive list of models. It is however indicative of the range and scope of the modelling involved.

<sup>3</sup> See Figure. 4.6 for an example of this type of model.

<sup>4</sup> The tooling element is included here in the Process models for simulation group of models.

are not discussed and implemented, and the study focuses on functional design, concept generation and evaluation followed by prototyping and testing.

### **4.3 A Mechatronic Case Study**

#### ***4.3.1 Mechatronic System Design Problem Description***

The automatic application of lubricant to industrial machinery provides a background for discussing the implementation of a mechatronic system. These systems are characterised by the need to accurately and consistently supply very small continuous volumes of lubricating oil and is often accomplished by means of a needle valve.

The initial statement of need is for the design of an automatic stand-alone oil lubricating system for industrial chain lubrication applications with an accurate and very low flow rate (of the order of 2 to 20 drops per minute) operating at ambient temperature in the factory environment.

#### ***4.3.2 Design Concept Development***

While there are single discipline solutions available to implement this task, it is more beneficial to generate a mechatronic solution for the problem. This becomes clear when the functional requirements for an automatic and adjustable oil dispensing system are considered.

The interdisciplinary and integrated nature of a mechatronic system means that the design process must be viewed from a number of standpoints. These include (but are not limited to) understanding functional requirements, user requirements including user interaction, the dynamics of the systems to be controlled and the interaction of the individual systems and subsystems. Each individual system or sub-system must be considered and understood in detail in order for the final integrated system to operate as a single entity to meet the end objective.

The aim here is to prove the general architecture of the design. Problems encountered can then be fed back into the design process to support improvements and enhancements. The design has to reflect the role that it performs and the environment in which it is used. Hardware and software have to work in harmony in order to be able to produce the desired effect in response to changes to the environment. An incorrect specification of the software or hardware, or an incorrect interpretation of the environment can result in an undesirable outcome. As a consequence of this interdependency, a problem in one area can have

repercussions in others. This, in turn, can create other downstream effects. Figure 4.2 describes the interrelated nature of a mechatronic system.

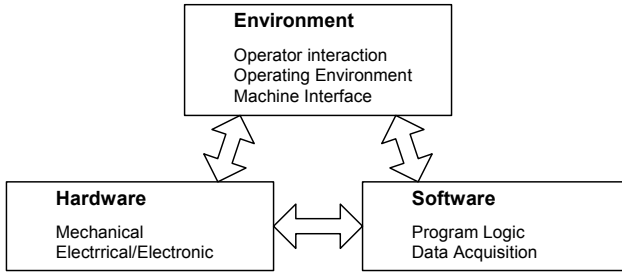
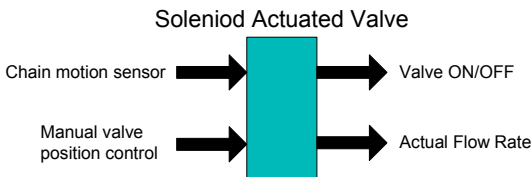

**Fig. 4.2** The interrelationship of environment, software and hardware

As the system architecture is heavily influenced by the environmental factors of Figure 4.2, it was necessary to test the oiler system in an appropriate operational environment. Described here is an approach by which the general operating requirements could be explored through the evaluation of a working prototype when tested in a real operating environment.

To this end, a number of local manufacturing companies were assessed to identify a chain driven machine that would benefit from automated lubrication. The machine selected was a ‘cooling tower’ at a local biscuit manufacture. This a chain driven rack that transports biscuit wafers through a refrigerated tower. The application is characterised by an abrasive environment caused by broken and crushed biscuit wafers interspersed with periods of high moisture due to the frequent high intensity cleaning regime.

Figure 4.3 shows a black box diagram of the system requirements. The main elements consist of a chain motion sensor enabling the unit to start and stop lubricant flow in response to the chain movement and a manually operated controller to adjust the flow rate through a needle positioning mechanism on the valve.

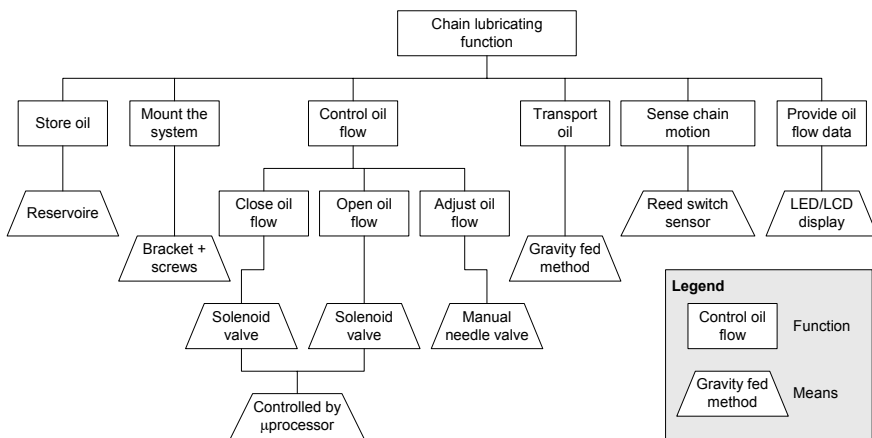

**Fig. 4.3** Black box function of the prototype oiler system

The key to being able to accurately and consistently control low fluid flow is the ability to establish the link between valve geometry and the flow characteristics of the valve. Once this has been accomplished, it is then possible to develop a mechatronic solution consisting of the mechanical and control elements required to manipulate the valve geometry to achieve the desired flow. What

makes this problem such a rich source of investigative subject matter is that there are many other factors that conspire to adversely affect the flow rate. These factors need to be identified, quantified and accounted for in the mechanism and control system. Their interrelationship is then what characterises a mechatronic system.

A mechatronic system can be broken down or decomposed into subsystems and sub-models for the purpose of analysis, but these cannot be used in isolation when determining the performance of a complete system. The decomposed functional representation for the oil lubricating system is shown in the functional block diagram of Figure 4.4. In this type of diagram, the highest level function, typically the complete system, is successively decomposed into its functions and sub-functions until a means or a method is found to realise the decomposed functionality.



**Fig. 4.4** A functional block diagram for an industrial oil lubricating system

This diagram can be further refined and quantified to produce a behavioural simulation model. Some parts of the system model are described in detail here. However, as part of the mechatronic design philosophy, it is important to be aware of the overall system and of the contributions of other key sub-models. In this case, these includes but are not limited to; the interaction of the fluid flow with the geometry of the needle valve, the effects of temperature on the geometry of the valve and the linear motion characteristics of the needle positioning device.

### 4.3.3 Detailed Design

Due to its simplicity and relatively low cost, the obvious choice for activating the valve is a solenoid. The use of a magnetically latching solenoid significantly reduces the power required compared to a regular solenoid by removing the need

to maintain current flow while the valve is open. This limits the current drawn from the supply to pulses when switching the flow on or off.

There are two important characteristics of latching solenoids that must be considered when incorporating them in a mechanical system. Firstly, by definition, a latching solenoid sits in one of two positions, with the plunger either *in* or *out*. In the *in* position, the plunger is held by an internal magnet but must be stopped by an external mechanism to prevent the plunger from exiting the body completely when the current is reversed. As such, it is not designed to be able to regulate the extent of plunger travel. Secondly, the ability of the solenoid to successfully move the plunger decreases exponentially as the plunger exits the solenoid body. This means that it is able to exert a strong force for very short travel applications, but displays a very weak force when fully extended.

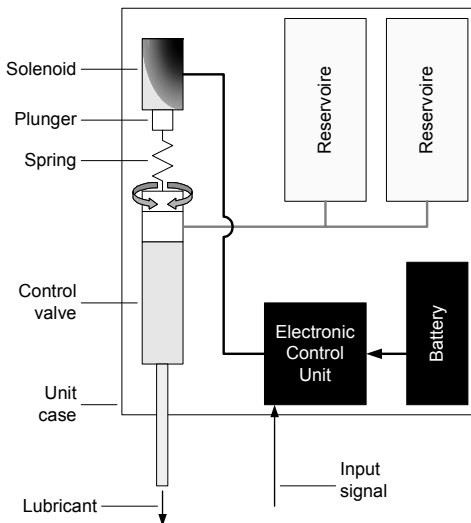

**Fig. 4.5** Oil lubricating system layout

Because of these characteristics, there is an immediate problem when trying to interface a latching solenoid with the needle valve. The needle valve requires a range of travels corresponding to the amount of needle lift available as set on the adjuster dial. This is approximately 3 mm, corresponding to the available travel of the needle between the closed and prime positions of the valve. As can be seen from the basic architecture diagram of Figure 4.5, a spring must be inserted between the needle valve and the solenoid to allow the solenoid full travel while the needle valve needle travel is restricted.

This now leads to the problem of matching the solenoid force and travel to the force and travel of the needle valve. As can be seen from Figure 4.6, the total distance required to travel by the solenoid plunger,  $x_T$ , is:

$$x_T = x_{RMV} + x_C \quad (4.1)$$

where  $x_{RMV}$  is the compression on the internal needle valve spring and  $x_C$  is the extension of the centre spring. The needle valve spring travel is limited by the adjustable stop and the total travel of the solenoid is the sum of needle valve spring compression and centre spring extension.

As the spring constant  $k$  can be defined by  $F = kx$ , where  $F$  is the force applied and  $x$  is the spring extension, the total spring extension can be defined as:

$$x_T = F/k_{RMV} + F/k_C \tag{4.2}$$

where  $k_{RMV}$  and  $k_C$  are the spring constants of the needle valve and centre spring respectively.

If the spring constants are known, it is possible to plot the total extension against applied force. Combined with the pull force/stroke information provided by the solenoid manufacturers, it is then possible to see the effect of different spring constants.

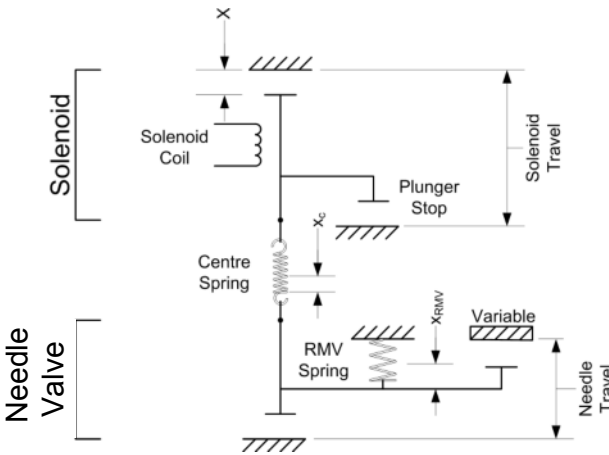

**Fig. 4.6** Mechanism diagram including valve and solenoid with intermediate spring

Plotted in Figure 4.7 are the force/extension characteristics for the needle valve spring on its own (RMV spring), the centre spring on its own (centre spring) and the combined effects of the needle valve spring and centre spring (composite). Also shown is the force/extension curve for a 20 W solenoid as provided by the manufacturer. The minimum stroke required of the solenoid is equal to the maximum extension of the composite spring as per Equation 4.1.

In the example given, it can be seen that the minimum stroke required of the solenoid to ensure the needle valve has moved through the full amount of travel possible is 3.75 mm as indicated by the change in angle of the composite curve and by the *Max extension* line. This is achieved with the needle valve spring and centre spring in series and corresponds to the needle valve spring reaching its limit of travel.

The centre spring line represents the case when the needle valve is closed and thus allows no compression of the needle valve spring. In this case, all the force is through the centre spring and a much higher force is required to achieve the same travel. As the minimum solenoid stroke length is set by the minimum needle valve stroke, this is the situation that places the highest load on the solenoid and it can be seen from the dashed lines that a force of 2.45 N is required to move the centre spring through the minimum stroke of 3.75 mm.

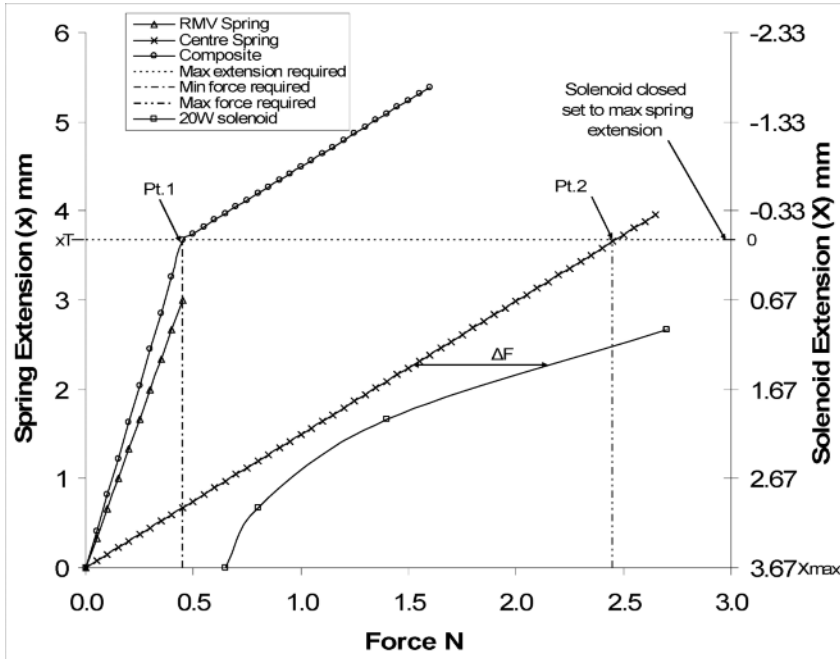

Fig. 4.7 Spring extension and force in relation to solenoid force

As the valve travel adjustment is achieved by limiting the travel of the needle valve spring, all possible force/extension combinations lie between the composite and centre spring lines and so the force range is 0.45 to 2.45 N. Changing either of the two spring constants alters the minimum stroke length required, which in turn alters the maximum force required.

The solenoid data shown on Figure 4.7 is presented relative to the plunger fully engaged position and has been converted from the force/stroke data supplied by the manufacturer. Taking this as a datum, the stroke = 0 point is set to the maximum spring extension line. This means that for all spring force plots above the solenoid force line, the solenoid should be able to work against the spring. If the centre spring line (also the worst case) were to cross the solenoid curve, it would indicate that the solenoid would start to move but then not be able to generate enough force to fully engage the plunger.



The benefits of a relatively high  $k_C$  spring constant relative to  $k_{RMV}$  are that this limits the total extension required, which in turn reduces the total force required when the needle valve is in the closed position.

However, there are consequential effects associated with changing the centre spring constant, as the solenoid power curve is linked to the total extension point. As the total extension reduces, the total travel required by the solenoid reduces, putting it in a more favourable power band.

This interrelationship means that there is a range of spring constants that could be suitable for this application. In practice, it was found that while the system was fairly insensitive to specific  $k_C$ , it was very sensitive to the particular position of the solenoid and plunger stop. This is because of conflicting positional requirements. The position of the solenoid is such that the following requirements must be fulfilled:

1. In the engaged position there is enough tension in the centre spring to be able to fully lift the needle valve while in the prime position.
2. There is enough tension in the centre spring to aid the disengagement of the solenoid plunger when the current is reversed. This is at a minimum when the needle valve is at the prime position.
3. There is no residual tension in the centre spring when the plunger is disengaged, as this will prevent the valve from fully closing and allow it to leak.
4. When conditions 1–3 are achieved, there remains enough power in the solenoid to move the plunger when the needle valve is in the closed position.

While it could be argued that condition 4 is unnecessary, it would be considered good practice, as the system needs to be able to operate when the RMV is ‘nearly closed’, and as this position is impossible to define, it is prudent to design the mechanism to activate when the RMV is closed.

The points above and Figure 4.7 can be formalised in terms of the difference between the force available from the solenoid and that required to open the valve,  $\Delta F$ , as marked on Figure 4.7.

The maximum force required to open the valve is determined by the position of Point 2 on the centre spring line, which in turn is determined by Point 1. If the needle and centre spring displacement is denoted by  $x$  and the maximum displacement required of the needle valve and the centre spring is referred to as  $x_T$ , this then marks the position of Point 1 when  $x_T$  and Point 1 can be determined by:

$$x_T = x_{RMV} + \frac{F_{\min}}{k_C} \quad (4.3)$$

where  $x_{RMV}$  is the needle movement required to fully open the valve,  $k_C$  is the spring constant of the centre spring and  $F_{\min}$  is the minimum force required to close the valve, taking into account the opening force of the fluid pressure head. In this way, the valve opening distance and the shut force of the valve determines the

spring constant required of the needle valve. The maximum force required to open the valve is determined by Point 2;

$$F_{\max} = k_C x_T \quad (4.4)$$

The force  $F_S$  generated by a solenoid is:

$$F_S = \frac{1}{2} \frac{N^2 I^2}{X^2} A_a \xi \quad (4.5)$$

where  $N$  is the number of turns of the solenoid coil,  $I$  is the current through the coil,  $\xi$  is the permeability of air,  $A_a$  is the cross-sectional area of the air gap and  $X$  is the displacement of the plunger.

For simplicity, all the values other than the plunger displacement can be amalgamated into a single term  $\tau$  that can be considered as the solenoid coefficient. The  $F$  value is dependent on the position of the solenoid relative to the valve and  $X$  is a vector in the opposite direction to  $x$  (as represented by the opposing scales on Figure 4.7). However, if the maximum travel of the solenoid is taken to be equal to the maximum travel required of the valve and centre spring;

$$|x_T| = |X_{\max}| \quad (4.6)$$

$X$  can be converted to  $x$  as:

$$X = x_T - x \quad (4.7)$$

Using a combination of Equations 4.5 and 4.7, it is possible to define  $\Delta F$  in terms of valve displacement  $x$  such that:

$$\Delta F = \frac{\tau}{x_T - x} - k_C x \quad (4.8)$$

It is interesting to note that the solenoid curve moves as the solenoid is moved relative to needle valve and that  $\Delta F$  is smallest in mid-stroke. It was noticed during testing that the operation of the system was particularly sensitive to the position of the solenoid relative to the needle valve and that the solenoid would stall mid-stroke if positioned too far from the needle valve. This corroborates the theoretical analysis.

It becomes difficult to prescribe predetermined parameters for future manufacture as there are a number of uncontrolled variables that mean each system has to be selectively assembled. Due to the manufacturing tolerances of the needle valve components, the needle valves themselves are individually tuned to

set the closed position relative to the adjuster dial. This means that the total travel for each needle valve is subtly different for each assembly. It has also been noted that there are notable differences in performance between solenoids, particularly for the plunger release force.

#### 4.3.4 Electronic Control Unit

The primary purpose of the Electronic Control Unit (ECU) is to control the lubricant flow in response to chain operation. The ECU inputs and outputs are summarised in Figure 4.8.

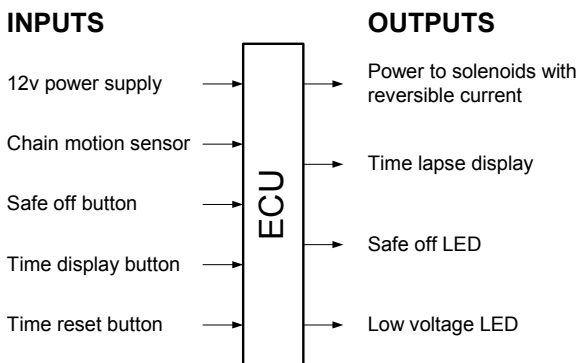

**Fig. 4.8** ECU inputs and outputs

This translates to form the following primary control operations based on the inputs and outputs for the controller:

- activate the lubricant flow when the chain is running and deactivate when the chain stops;
- monitor the chain running time and display run time when requested.

Secondary operations include:

- monitor battery level and display warning signal when low;
- provide a function to safely deactivate solenoids and store time counter to memory;
- allow time counter to be reset.

A PIC16C84F microprocessor was chosen for implementation in the prototype system as it supported a high level of functionality at low cost and is also relatively easy to update and allows the oiler to work as an independent unit. This

means that bulky and expensive PC based controllers are not required and the oiler does not rely on the presence of such a controller.<sup>5</sup>

As a result of the user trial of the finalised prototype system, it was found that a flexible architecture was essential to allow the base system to be adapted to the variety of user needs found in industry. The bespoke nature of each application requires a flexible architecture that can be quickly and easily adapted to meet the application requirements. For this, it is necessary not only to have a scalable physical architecture but a flexible logic control system that can be adapted to user needs. The adoption of the mechatronic design process shown in Figure 4.1 can help to establish a more rigorous and flexible product platform from which a number of design variants can be derived to meet the user's specific needs.

In addition to the mechatronic modelling of the lubricating system and to illustrate the other modelling techniques used in designing a mechatronic system such as this one, fluid behaviour has been modelled and studied using a computational fluid dynamic software system to provide precise control algorithms.

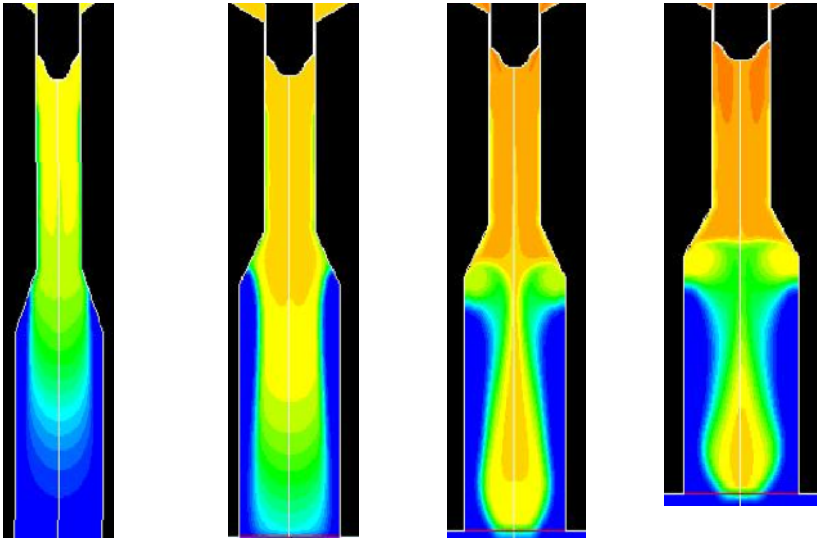

**Fig. 4.9** Simulated formation of oil drops

Figure 4.9 shows some screen captures of simulation results, clearly showing the formation of oil drops. Table 4.1 then lists some key properties of the particular type of oil used for this application. This study alone has reduced time significantly through ensuring an understanding of oil flow behaviour for different

---

<sup>5</sup> For further information about the full design and investigation of this mechatronic system, please refer to: Zante R (2008) *A mechatronic investigation and design synthesis of very low flow needle valves*, Ph.D. Thesis, Department of Design, Manufacture and Engineering Management, University of Strathclyde.

temperatures. This modelling technique has been used to assess the impact of temperature on the oil flow and the results can then be used in the control algorithms to precisely adjust the valve behaviour when a change of temperature is detected.

**Table 4.1** Lubrication oil properties

Temperature	Density	Absolute viscosity	Surface tension	Wall adhesion
35°C	814kg/m <sup>3</sup>	0.1476p	0.023N/m	85°

## 4.4 Conclusions

The development and adoption of a formal mechatronic system design process is an effective way of improving the mechatronic system design process. A benchmark study relating to the design of a similar product within the chosen company indicates that the development time has been reduced from seven years to one year for a high precision oil lubricating system such as the one illustrated in this chapter. This case study clearly demonstrates that the system structure and the effectiveness of the final design are greatly influenced by the design methodology used to create it. Specifically for this case study example, the following process has been used:

- create a working concept supported by working principles and product design elements;
- development of functionality through function decomposition in response to perceived user requirements;
- detail design and analysis to ensure the concept is fully embodied by using available techniques such as behavioural energy based, kinematic simulations;
- prototype testing in lab a using duty cycle;
- implementation of a working system in a user environment;
- modification in response to actual user requirements.

Using the simplified approach above allows for the development of a flexible modular structure derived from the functional decomposition and with a scalable power circuit. This allows the mechatronic solution to adapt to the different types of valves required for different applications. The programmable logic and associated codes can be easily modified to adapt to varying user and hardware requirements.

Modelling can be an important part of the mechatronic system design process. This includes understanding the major subsystems at work within the overall system and the role played by each subsystem in respect to its effect on the overall system structure. In the case study reported, it was necessary to identify and model a hierarchy of sub-systems in order to be able to develop a coherent design

rational for the problem at hand. This clarifies the main parameters that influence the control of very low fluid flows.

## References

1. French M (1985) *Conceptual design for engineers*, 2nd ed, Design Council
2. Pahl G, Beitz W (1996) *Engineering design – a systematic approach*, 2nd ed, Springer Verlag
3. Bradley DA, Dawson D, Seward D, Burge S (2001) *Mechatronics and the Design of Intelligent Machines and Systems*, CRC Press
4. Bracewell RH, Chaplin RV, Langdon P, Li M, Oh V, Sharpe JEE, Yan XT (1995) *Integrated Platform for AI Support of Complex Design (Part 1)*, AI System Support for Conceptual Design, ed. Sharpe JEE, ISBN 3-540-76000-8.
5. Borg J, Yan XT, Juster NP (2000) Exploring decision's influence on life-cycle performance to aid 'Design for Multi-X', *Artificial Intelligence for Engineering Design, Analysis and Manufacturing*, **14**; 91–113
6. Yan XT, Sharpe JEE (1994) A system simulation platform for mechatronic product design, *European Simulation Multi-Conference*; 789–793
7. Yan XT (2003) A multiple perspective product modelling and simulation approach to enhancing engineering design decision making, *Int. Journal Concurrent Engineering*, **11** (3); 221–234
8. Dymola, [www.dynasim.se/index.htm](http://www.dynasim.se/index.htm)
9. Modelica, [www.modelica.org/](http://www.modelica.org/)

# Chapter 5

## A Mechatronic Design of a Circular Warp Knitting Machine

Memiş Acar<sup>1</sup>

### 5.1 Introduction

The application of mechatronics is not limited to the range of consumer products encountered in everyday life. Large scale industrial machines such as those used in the textile industry also benefit from the adoption of an integrated and mechatronic approach to their design and operation. This chapter tells the story of the application of such an approach to the design and development of an innovative method of producing warp knitted fabrics using a circular configuration of needles.

Commodity knitted garments such as t-shirts are made using *weft knitting machines* which are of circular configuration. Typically, there are hundreds of needles around the circumference of the machine and only one end of yarn is fed to all the needles spiralling around the machine and forming knitted loops to produce the fabric. In comparison, warp knitting differs from weft knitting in that each needle has its own individual yarn feed, rather like the warp yarns of a weaving machine, and also is performed by linear (flat-bed) *warp knitting machines* containing two needle bars, one for each side of the two-layered fabric-joined on the edges by yarns knitting on each bar to produce a circular fabric.

Warp knitting has generally been considered as practicable only with linear (flat-bed) machines with needle bars that swing the yarns to and fro at each cycle. By operating in a circular configuration, a warp knitting machine requires a more complex configuration. Thus, until recently, it has not been possible to successfully design, build and operate a warp knitting machine in the circular format. A mechatronic approach to design and implementation makes the application of circular warp knitting technology feasible.

---

<sup>1</sup> Loughborough University, UK

## 5.2 Warp Knitting Cycle

Flat-bed warp knitting machines employ three main mechanisms to produce stitches. Namely, (i) a *reciprocating* motion of the needles in the vertical plane to form and cast off stitches, (ii) a *swinging* motion to move the yarns from the front to the back of the needles (and *vice versa*), and (iii) a *shogging* motion to produce overlaps and underlaps parallel to the plane in which the needles are laid.

The knitting needle cycle for a flat-bed warp knitting machine can be described in relation to the six stages shown in Figure 5.1. Starting with the needles at their highest position and having the previous loops around their stem, at stage (1), the threads are swung from the back to the front of the needles. At the *overlap* stage (2), a thread is laid under the hook of the needle by performing a sideways *shog* from one needle space to the next. The threads are then swung to the back of the needle at stage (3). The needles then start to move downwards at stage (4).

The loops from the previous cycle that are located under the needle latch cause the latches to close as the needles continue to move down, eventually reaching the top of the needles when they are *cast-off* and pulled down by the fabric tension. At the *underlap* stage (5), the threads are shogged again, this time behind the needles. As the needles rise again at stage (6), the threads in the hooks push open the latches, move further down with respect to the needles and hence become the newly formed loops.

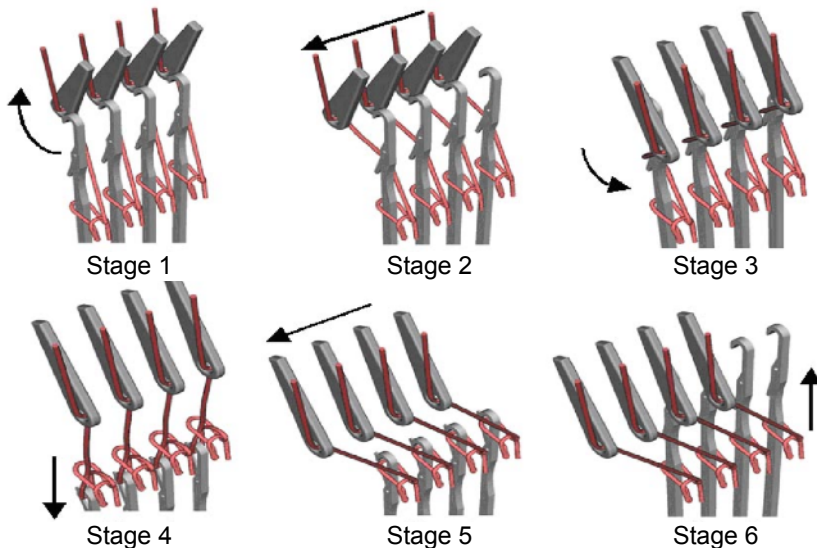

**Fig. 5.1** Stages of warp knitting as performed on a flat-bed machine



During the *underlap* period, the needles are in their lowest position. Each thread should travel from the point where the last stitch has been cast off to the new position just past the target needle. Its end position should be such that the target needle rises in front of the thread. It should also be at an appropriate height to enable the thread to pass under the needle hook when the overlap is performed.

The *overlap* motion begins after the needle has risen to its highest position. During the overlap which wraps the yarn around one needle only the thread is positioned under the needle's hook and sufficiently near the stem to ensure the needle picks up the thread on its downward motion.

### 5.3 Circular Warp Knitting Machine Concept

Referring to Figure 5.2, the patterning mechanism requires the synchronised motions of a number of different machine functions. On a circular machine, the yarns are threaded through the radially perforated rings when the shogging movement becomes a rotation of these rings. A pattern chain then comprises a number of rotational movements of the rings in synchronisation with the mechanism responsible for the vertical reciprocating motion of the needles. The rings must therefore perform two distinct rotations and two dwells during a machine cycle. The needles then reciprocate in the vertical plane to form and cast stitches.

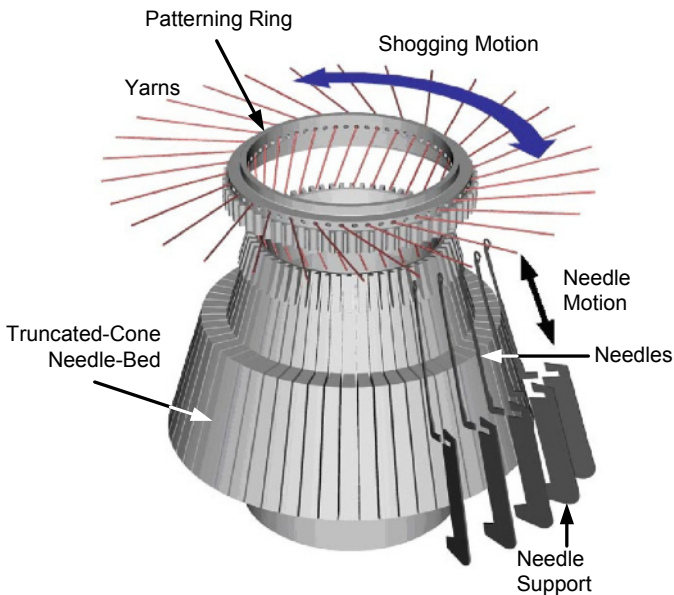

**Fig. 5.2** Patterning ring and needles on a truncated-cone needle-bed

The swinging motion that moves the yarns from the front to the back of the needles (and *vice versa*) is provided by the needle bars in the flat-bed machines, something which is not possible with the circular machines. This provides a major challenge in the design of circular warp knitting machines and a totally novel approach is therefore required to achieve this component of motion of the yarn.

The slotted (or *tricked*) truncated-cone needle-bed shown in Figure 5.2 is such a novel concept which, rather than the traditional cylindrical needle-beds used in circular weft knitting machines, offered a feasible solution. This design enabled the needles to slide in the tricks (slots) cut in the surface of a truncated conical needle-bed. The needles sliding in the inclined tricks on the conical surface would then move their hooked end radially inward as they ascend and outward as they descend, combining the two of the successive motions required for the knitting cycle in one; namely, a reciprocating motion of the needles in the vertical direction and the swinging of the threads in the radial direction. The advantage of this concept is that there is no need for an extra mechanism to perform the swinging motion of the needles that is required for a warp knitting cycle.

The tricked truncated-cone is an approach whereby the whole swinging mechanism can be avoided as it combines both the swing and the vertical reciprocation in one simultaneous motion of the needles, making it a unique solution to the problem thus outweighing all other possible concepts considered. It not only increases the speed at which a stitch is produced, but more importantly, it also simplifies the movement of the yarns as it involves only the tangential motion of threads relative to the needles.

The shogging motion (moving threads in the circular direction across a certain number of needles to the desired needle position) can be achieved by rotation of patterning rings that guide the yarns that are themselves threaded through radially perforated eyelets. The rings must perform two distinct rotations (overlap and underlap) during a machine cycle. The direction and amplitude of the rotations will depend upon the fabric structure being created. However, an overlap will always be carried out only over one needle, while an underlap can be under several needles and could therefore require a larger rotation of the rings.

A knitting pattern chain comprises a number of rotational movements of the rings in synchronisation with the main mechanism responsible for reciprocating the needles in the tricks on the truncated conical needle-bed. The greater the number of rings present, the greater the patterning possibilities. However, the amount of space available for them and the complexity of the yarn paths generally restrict the number of patterning rings that can be accommodated in a machine.

The whole system, including the actuators, software and controls requires synchronisation and therefore had to be considered at this conceptual stage. The mechatronic design philosophy then needs to be applied.

## 5.4 The Needle Reciprocating Mechanism

A cam and follower mechanism was chosen to reciprocate the needles because it is a simple and precisely repeatable method of transforming rotational motion into a combination of linear rises, dwells and returns. This mechanism reciprocates the needle support ring in the vertical plane, which in turn moves the needles by sliding them along the inclined needle-beds.

The design of the rise-dwell characteristic of the cam is very important as it provides the synchronisation with the patterning mechanisms and the maximum speed of the machine depends on its optimisation. The dwells correspond to the underlaps and overlaps of the patterning mechanisms. During the dwell period, the set of needles remains stationary as the threads are wrapped around them by the patterning rings.

## 5.5 The Patterning Mechanism

A knitting pattern consists of a number of varying lengths of underlaps each followed by an overlap that wraps the thread over one needle each time. The main function of the patterning mechanism is to provide the needles with threads at the appropriate points in the knitting cycle following a specified sequence which would produce a given knitted pattern. The previously patented patterning mechanism concepts [1, 2] are all mechanically controlled, use two patterning rings driven by cams and have a maximum pattern length of twelve machine cycles.

The patterning rings through which the yarns are threaded radially (Figure 5.3) need to be rotated in order to provide the required shogging motion which is the most important function in a warp knitting machine as it determines the machine's patterning capability. Having isolated the swinging problem from the shogging one, the latter is now simplified to that of designing a means to rotate threaded rings about their centre in the smallest possible space while allowing for easy threading of the rings. The flexibility of the patterning depends on the ease of modifying the motion performed by its shogging mechanism and the length of the pattern chain.

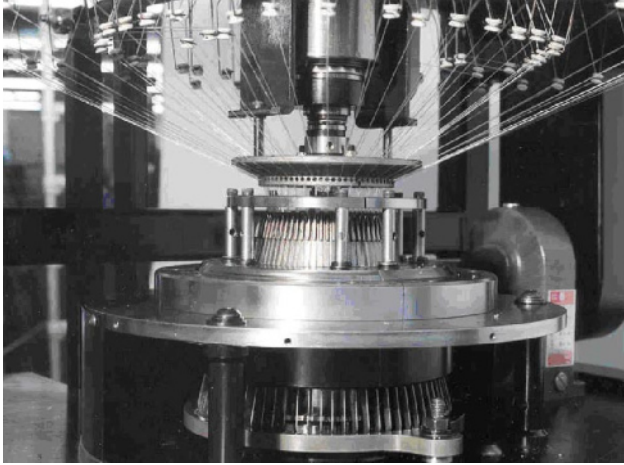
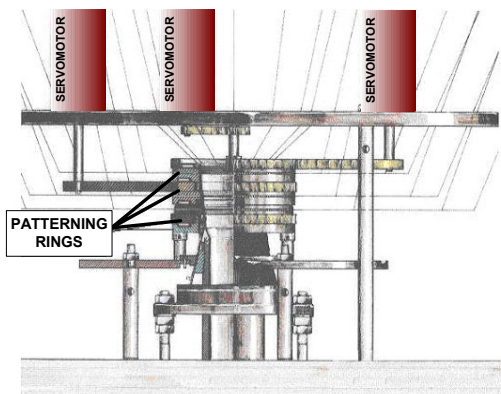

**Fig. 5.3** Prototype showing truncated-cone needle-bed and patterning rings

### ***5.5.1 Servo Motor Selection***

The patterning mechanism for an innovative mechatronic solution requires very fast responses and accurate position control. AC brushless servo motors configured as in Figure 5.4 could meet these requirements at high machine speeds of 1,000 rpm to rotate the three patterning rings. The servo motor controllers can store programs with the series of movements required by a given fabric design. This solution offers considerable reduction in the machine parts used.

The servo motor program should include the appropriate dwells in the ring rotation when the needles are being raised or lowered and a means for synchronisation between the shogging movement and the knitting mechanism should be devised.



**Fig. 5.4** Servo motor drive concept

The main parameters involved in the selection of a servo motor are the torque required by the system (including the servo motor itself) and the speed at which the motor will run. Different angular velocity profiles can be used to perform a given rotational movement within a set time. Using a triangular speed profile for a 20 ms underlap or overlap motion corresponding to 1000 rpm machine speed (see Figure 5.5), the minimum angular acceleration that the system would require and the angular velocity which it would reach can be calculated.

If the time allowed for accelerating and decelerating is reduced, the speed curve would turn into the trapezoidal shape shown in Figure 5.5; the acceleration would increase as would the torque and power requirements. The peak angular velocity, however, would decrease. The area under both curves is the same as it represents the angular position achieved after the displacement.

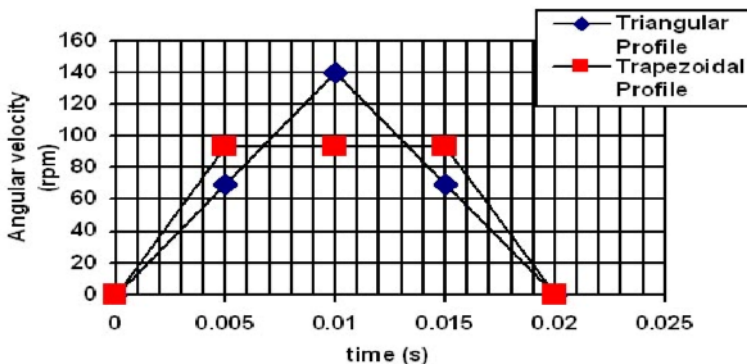

Fig. 5.5 Motor requirements

Physical motor size (and rotor inertia) is directly proportional to power capability. In order to obtain the smallest motor capable of fulfilling the system requirements, the power used to perform the move must be minimised.

Although the selection process ensures that the motor has sufficient power to accelerate the load in the calculated time, the motor response might not be fast enough to achieve the motion required within the specified time. It was therefore necessary to first test the servo drives (motor and motion controllers) without load to ensure that they were capable of reacting as fast as was necessary. The difference in the performance of the servo drives could be related to the difference in the mechanical construction of the motors as well as to the control algorithms used. The motor with the best performance without the applied load was then tested with a disc manufactured to simulate the same reflected inertia as the real system would produce. This simplified test procedure ensures that the motor can respond within the required time [3].

## 5.6 The Prototype

In the prototype circular warp knitting machine, one-third of the machine cycle was deemed to be sufficient for the needles' movement. This leaves two-thirds of the knitting cycle to perform the underlap and overlap. Assuming that the maximum speed of the machine is 1,000 rpm and that a single knitting cycle takes place in 60 ms, this leaves only 20 ms for each of the underlap and overlap rotations. The prototype used a 72-needle truncated-cone (Figure 5.3) with a ring rotation of  $80^\circ$ , equivalent to 16 needle spaces. Each  $80^\circ$  motion is then equivalent to accelerating from zero to 139 rpm in 10 ms and decelerating to zero again in the remaining 10 ms,

The patterning mechanism for the knitting machine was then designed, built and tested without yarns. This mechanism consists of three rings each controlled by a servo motor (Figure 5.6). The motors are connected to the load by timing belts, ensuring an appropriate gear ratio. The maximum rotation of  $80^\circ$  was achieved repeatedly with alternating directions in the specified time of 20 ms, illustrating a very fast response. The complete prototype machine of Figure 5.7 was then built to industrial standards, tested and has since gone through successful industrial trials.



**Fig. 5.6** Servo motor controlled patterning mechanism

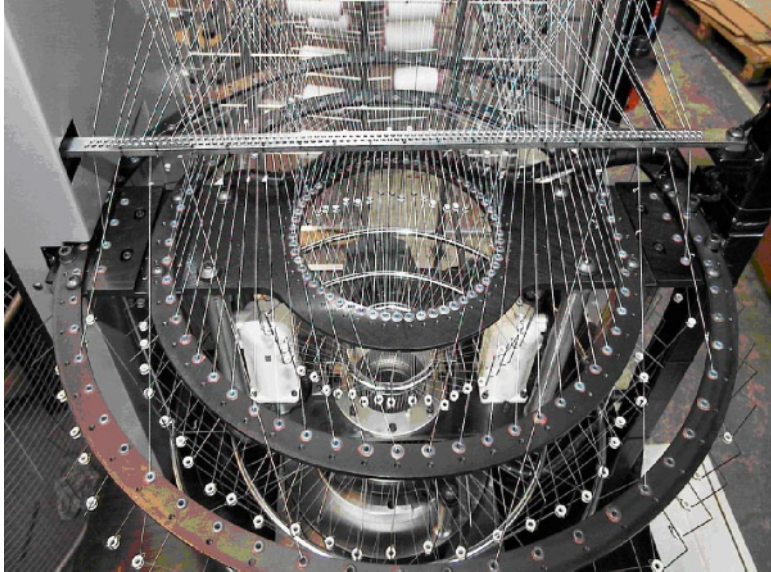

**Fig. 5.7** The servo motor driven patterning rings on the prototype machine

The development of a new knitting pattern is reduced to stepping the motor until it reaches the desired position for each motion and recording those values into the motion controller memory. The mechatronic shogging has the potential of creating pattern chains that are only restricted by the size of the memory of the hardware used, allowing hundreds of machine cycles. The patterning flexibility and the simplicity of design that was achieved by the mechatronics approach offered an optimum solution.

### ***5.6.1 Servo-controlled Needle Motion***

The main knitting mechanism, that is, the one responsible for the needle motion, could also be servo-controlled giving further control over the synchronisation between needles and yarns. This has not been implemented in the current design, but it can deploy the method proposed by Yao *et al.* [4] to improve the motion characteristics of a cam follower by controlling the cam speed through the use of servo drives.

### ***5.6.2 The Yarn Feed Mechanism***

A positive yarn feed mechanism was developed to control the feed rate of the yarns to the needles. By changing the feed rate and the knit pattern, the diameter of the knitted structure can be controlled and altered as required, offering new fabric formation opportunities. This novel concept opens up many industrial applications from medical textiles to fruit packaging.

### ***5.6.3 Truncated-cone Optimisation***

The use of a truncated-cone needle-bed to enhance the interaction between the needle and yarn movements is one of the main innovations of the circular warp knitting machine design. By using a tricked truncated cone to support the needles, two of the traditional displacements performed by the needles are merged into one.

The prototype machine used a 15° half-cone angle. However, it is essential that the optimum taper angle of the cone, a novel and unique feature of this design, needs to be investigated to find the most efficient interaction between the needle and yarn motions. The optimum inclination of the cone depends on a number of interrelated geometrical factors in the design of the patterning mechanism. A parametric mathematical/graphical model was developed to predict the equations that govern the relationship between these parameters and to find the optimum combinations [5].

## **5.7 Conclusions**

A new concept of producing warp knitted fabrics using of an innovative circular disposition of the needles was developed. The truncated-cone needle-bed concept, a novel approach that combined the needle reciprocation and swinging in one movement of the needles, was used in conjunction with the mechatronic design process.

A novel servo-controlled mechatronic patterning mechanism for a circular warp knitting machine was designed, built and tested. It requires very fast responses and uses AC brushless servo motors to control three patterning rings. Having proven the concept, a mechatronic system was developed using AC brushless servo motors to control three patterning rings. This novel concept has significantly reduced the machine parts required and enabled the knit pattern changes to be realised by only changing software parameters. The new design not only makes its patterning capabilities significantly better than any mechanical system, but also meets the response requirements that will allow the machine to be run at the 1000 rpm design speed. A prototype machine was manufactured and tested.



A method for the selection of servo motors was also developed. Based on minimising the power required to perform the fastest motion required by the application, it ensures the selection of the smallest servomotor suitable for the application. This is very significant as it minimises the cost of the system: servo motor power capabilities determine the frame size, which in turn governs the cost.

**Acknowledgments** This work was a joint project between Loughborough University and Tritex International Limited. The author is grateful for the financial and technical support received from the Teaching Company Directorate and Tritex International Limited. The design presented here was the products of team effort and university-industry collaboration. The author therefore gratefully acknowledges the contributions made by the Teaching Company Associates Dr. Sylvia Mermelstein and Mr. Darren Hale, his colleague Dr. Mike Jackson and the Tritex chief design engineer Mr. Kevin Roberts.

## References

1. Borenstein M (1986) *Rundstrickmaschine, European Patent*, Pat No. 0 200 094, Tel Aviv, Israel
2. Ragosa IV (1990) *Circular Warp Knitting Machine*, UK Patent, No. 2 039 544 A, 20 November.
3. Mermelstein SP, Hale D, Acar M, Jackson MR, Roberts K (2001) Patterning Servo-mechanism for a Circular Warp Knitting Machine', *Mechatronics Journal*, **11**(6); 617–630
4. Yao Yan-an, Zhang Ce, Yan Hong-Sen (2000) Motion Control of Cam Mechanisms, *Mechanisms and Machine Theory*, **35** (4); 593–607.
5. Acar M, Mermelstein SP (2007) Modelling the Pattern Creation Process for the Optimum Design of a Circular Warp Knitting Machine Using a Conical Needle-bed, *J of the Textile Institute*, **98**(5); 397

# Chapter 6

## Mechatronics and the Motor Car

Derek Seward<sup>1</sup>

### 6.1 Background

“Revolution” is an often overused word. However, it is no exaggeration to say that a mechatronic revolution took place in the world’s car industry during the mid to late 1980s and early 1990s. It has been estimated that during this period, for the first time, the cost of embedded automotive electronic and computer systems exceeded that of the metal in a typical executive car. It was also during this period that long established, multi-million pound (UK) industries, such as carburettor manufacturers, ceased to exist and other major companies were forced to reform and regroup to meet the mechatronic challenge.

#### 6.1.1 Vehicle Mechatronic Systems

The extent to which mechatronic systems have penetrated the modern motor vehicle is often not realised. Some examples are:

##### *Engine Management [1]*

A breakthrough in engine efficiency and reliability was achieved by the replacement of traditional mechanical ignition timing and fuel delivery systems with software-based engine management.

An important side effect of processor-controlled engine management is the ability to diagnose and log system faults which can then be downloaded by garage mechanics to guide repair and maintenance. One example is the routine performance of “reasonableness” checks on sensor output data.

---

<sup>1</sup> Lancaster University, UK

More advanced systems can compensate for system errors to keep the vehicle operational, often at reduced performance levels until proper repairs can be carried out.

### *Suspension*

Although not yet standard in most vehicles, mechatronics has enabled the production of active suspension systems that can optimise comfort and road holding by making subtle real-time adjustments to suspension geometry in response to displacement sensors and accelerometers. Some cars are now fitted with user-adjustable suspension settings so that the driver can choose between 'sport' or 'comfort' settings as well as tyre pressure monitors.

### *Brakes [2]*

Virtually all cars are now fitted with an Anti-lock Brake Systems (ABS). The system constantly monitors the rotational velocity of each of the four wheels on a vehicle. They are empowered to reduce the braking effort on an individual wheel if it is sensed that it is about to lock and hence induce a skid.

Closely related systems are 'traction control' which prevents wheel spin and 'stability control', which as the name suggests, can intervene and override driver input if the overall stability of the vehicle is threatened.

### *Transmission*

An increasing number of automatic and semi-automatic transmission systems use highly complex processing to generate smooth gear changes whilst optimising both performance and economy. In addition to giving the driver an element of choice over the degree of 'sportiness', some advanced systems claim to 'learn' the driving style of the user and provide the required responsiveness.

### *Air Bags [3]*

Air bags and other defensive mechanisms such as seat-belt tensioners are increasingly recognised as essential for mitigating the effects of collisions. Air bag technology has changed from being an extra item on expensive cars to a standard item on everyday cars, and the number of such devices per car has increased significantly. Whereas a single air-bag utilised a simple inertial sensor to trigger its actuation, multiple air-bag systems, as shown in Figure 6.1, use a dedicated controller to coordinate the most appropriate response in a crash.

### *Security*

The majority of cars are now fitted with an integrated access and security system that includes remote central locking together with alarm and engine

immobilisation in the event of unauthorised entry. A common facility is ‘keyless entry’ whereby Bluetooth technology is used to identify an approaching owner. Increasingly, cars are also being fitted with hidden GPS-based tracking devices to locate the vehicle in the event of theft.

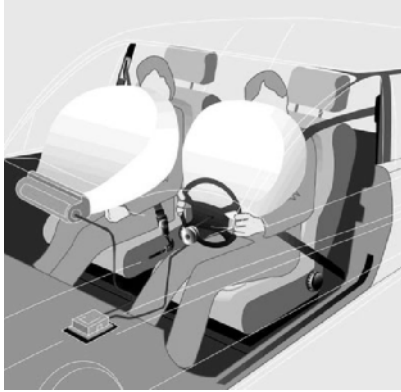

**Fig. 6.1** An airbag system

### *Comfort, Communications and Entertainment*

These are the areas where car users are most aware of the impact of mechatronic systems. Climate control senses the internal temperature and adjusts heater, air conditioning and fan levels to maintain desired preset conditions. The driver’s seat position is remembered and automatically adjusted to suit a new driver based on data stored in the car keys. The volume of the radio increases to compensate for increased road noise as the vehicle accelerates. Telephone calls can be voice activated and the entertainment system detects incoming phone calls and mutes the music accordingly.

### *Driver Aids and Information*

The driver is increasingly supported by many advice and guidance systems. Lights and wipers contain sensors that switch them on and off to suit the weather and road conditions. Warning and advice are provided on such matters as frost on the road, coolant level and service interval. Parking sensors provide drivers with an audible warning to prevent a collision during reversing. A trip computer gives information on fuel consumption and average speed, and cruise-control monitors vehicle speed and sends commands to the engine management system to maintain a desired speed under varying road conditions. GPS navigation systems communicate with satellites and provide the driver with detailed navigation instructions, congestion, and accident black-spot warnings. When an air bag is deployed, an automated call can be placed to an emergency processing centre and a conversation with the driver initiated so that emergency vehicles can be despatched as appropriate.

### *Drive-by-wire*

Many modern aircraft have now made the transition to “fly-by-wire” which involves the replacement of mechanical linkages to the control flaps by electronic signals generated by multiple computers. Cars have already started to move in this direction with electrical power steering, parking brakes, communications buses and wire-controlled throttles. The trend is expected to continue, however, there are clear safety concerns over removing the physical links to such items as the main brakes. An extension of this concept, the ‘smart wheel’ as developed by Siemens, is shown in Figure 6.2. [4].

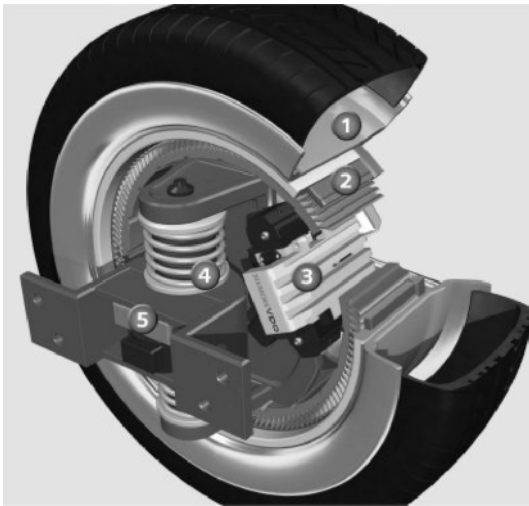

**Fig. 6.2** Siemens *eCorner* ‘smart wheels’ future concept. The hub motor (2) is located inside the wheel rim (1) and the electronic wedge brake (3) uses pads driven by electric motors. An active suspension (4) and electronic steering (5) replace conventional hydraulic systems

### **6.1.2 Drivers for Change**

It is interesting to consider why, after a hundred years of car production, the mechatronic revolution took hold in the way that it did. It is possible to identify a series of powerful drivers that coincided at that time:

#### *Reliability*

It is generally accepted that the modern motor car is now more reliable than ever before. This is partly due to pressure from the car-buying public and competition between manufacturers. However, a key enabling technology is the widespread adoption of electronic ignition and fuel injection. By far, the majority of problems associated with poor starting or bad running were related to the mechanical wear

of components in the ignition and fuel delivery systems. Modern electronic engine management systems largely cured these problems.

### *Economy and Performance*

It was traditionally recognised that a car's engine can be optimised for either economy in terms of fuel consumption or performance in terms of power output. The standard approach for increasing performance was to increase the flow of air/fuel mixture through the engine by means of larger and multiple carburettors which invariably had a deleterious effect on fuel consumption.

Paradoxically, the first commercial adoption of electronic fuel injection was on high performance 'GTI' models where the main emphasis was on further increases in power. However, it was quickly realised that the much enhanced control over the fuel/air mixture that electronic fuel injection afforded could also be exploited for significant benefits in economy. More recently, this technology has enabled a major transformation in both the economy and performance of diesel engines.

### *Security*

Pressure from insurance companies and the police led to a demand for significant improvements in vehicle alarm and immobilisation systems.

### *Environmental Protection*

Once it became clear that there was a valid technical solution, legislation was introduced by governments to reduce harmful emissions from vehicles. Apart from the complete abolition of lead additives in petrol, the main emphasis was on the reduction of carbon monoxide from exhaust gases.

Exemptions were introduced for older vehicles because traditional mechanical carburettor systems are not capable of delivering the low levels demanded by the legislation. Thus, manufacturers were forced to move to mechatronic engine management.

### *Safety*

Customer demand for increased passenger safety led to the widespread adoption of stability enhancing technologies such as ABS brakes and traction control as well as measures to mitigate the effects of a collision such as air bags and seat belt tensioners.

### *Enhanced Functionality*

Mechatronics has provided manufacturers with the ability to offer enhanced functionality across many aspects of the motor car. Manufacturers have used this opportunity to distinguish basic models from top-of-the-range models and to

generate additional income from the provision of factory-fitted extras. As specific systems have become more cost effective, competition between manufacturers has been an important driver in moving enhanced features down the model range.

## 6.2 Engine Basics

Before considering three automotive mechatronic systems in detail, it is necessary to understand the basic operation of the internal combustion engine. The rotating *crankshaft* at the bottom of the engine is connected to the piston and causes it to rise and fall in the *cylinder*. The valves at the top of the engine open and close at appropriate times in order to admit fuel to the cylinder and to allow burnt exhaust gasses to be expelled. The most common car engine uses the four-stroke Otto cycle [5].

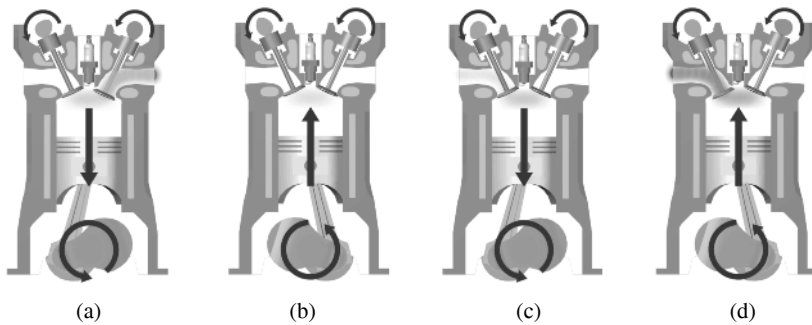

**Fig. 6.3** The four-stroke Otto cycle, (a) induction stroke, (b) compression stroke, (c) power stroke, and (d) exhaust stroke

The cycle starts with the *induction stroke* of Figure 6.3 (a). With the piston moving downwards in the cylinder, the inlet valve opens and the air/petrol mixture is sucked into the cylinder. When the piston is at the bottom, the inlet valve closes.

The piston then starts to move upwards, compressing the fuel mixture to about a tenth of its original volume. This is the *compression stroke* of Figure 6.3 (b). When the piston is close to the top, the spark plug ignites the fuel, causing combustion and the expanding gasses to drive the piston downwards in the *power stroke* as shown in Figure 6.3 (c). The final stage is the *exhaust cycle* of Figure 6.3 (d). The piston rises again and the exhaust valve opens to allow the burnt gases to escape. The cycle then repeats. Thus, the crankshaft makes two revolutions in each cycle.

The four-stroke engine can have from one to twelve cylinders, though the commonest number for passenger cars is four.

It can be concluded from the above that three key system requirements are:

1. The spark plug ignition must be precisely timed in relation to the movement of the piston. Sparking normally occurs just before the piston reaches the top (said to be advanced), though the precise position varies with fuel type.
2. The ratio of air/petrol fuel mixture must be carefully controlled. The 'ideal' mixture is known as the stoichiometric ratio and is 14.68 parts of air to one part of fuel by weight. A slightly lower ratio (12.6:1) is known to give maximum power and a higher ratio (15.4:1) is best for economy [6].
3. The valves must open and close at exactly the right stage of the cycle. This is one element of the system that is still under purely mechanical actuation (a *camshaft* driven by a belt or chain from the crankshaft). However, electronic valve control is an active research area and promises even more benefits in terms of economy and performance in future vehicles.

## 6.3 The Mechanical Solution for Ignition Timing and Fuel Delivery

### 6.3.1 Traditional Mechanical Ignition Timing

The main component in traditional mechanical ignition timing is the *distributor* of Figure 6.4 (a) [7]. The purpose of the distributor is to trigger a release of high voltage electricity from the coil and distribute it to the appropriate spark plug. The triggering is performed by the contact breaker or *points* shown in Figure 6.4 (b). An upper central shaft in the distributor is turned by a lower shaft connected to the engine which causes a multi-sided cam to revolve inside the body of the distributor. The cam separates the circuit breaker each time a spark is required. The *rotor-arm* on top of the rotating shaft then makes contact with the appropriate plug lead terminal to send the high voltage to the appropriate spark plug. The *condenser* (or capacitor) is present to prevent the initial spark jumping across the contact breaker gap and eroding the contact breaker surfaces.



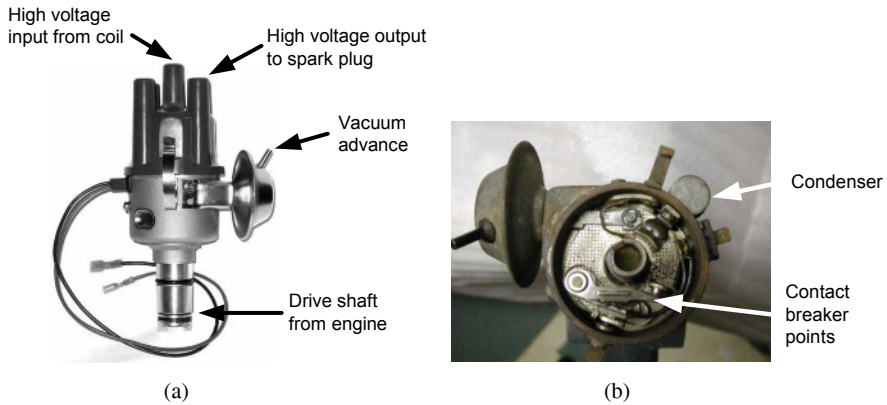

**Fig. 6.4** A 4-cylinder distributor, (a) external view, and (b) internal view

The initial ignition timing is set by rotating the body of the distributor around the central shaft so that the cams break the points at the correct time. However, for maximum efficiency and performance, the spark plug needs to fire increasingly in advance of the piston reaching the top of the cylinder (*Top Dead Centre* or TDC) as the engine speeds up. This is achieved by the incorporation of centrifugal weights that vary the angular relationship between the upper and lower shafts. The aim is for the spark plug to fire so as to give the relatively slow combustion process enough time to develop maximum pressure just as the piston is starting to descend. If the spark timing is too early, there is the danger that the maximum cylinder pressure is developed whilst the piston is still rising. This produces huge stresses in the engine and is known as *knocking*. Paradoxically higher octane fuels burn slower and so the ignition timing needs to be more *advanced* to allow more time for combustion. The danger however is that if the owner fills-up with lower octane fuel, there is the likelihood of knocking.

Yet another refinement is the *vacuum advance*. At idle, when little air/fuel mixture is available to the engine, the inlet manifold will be at negative pressure. This is used via a diaphragm to slightly rotate the plate that supports the contact breaker points to again advance the spark.

As previously stated, many reliability problems with cars originated with the ignition system. The contact breaker points in particular are subject to both wear and the accumulation of dirt. They require routine replacement and adjustment to keep the engine running smoothly and efficiently.

### **6.3.2 Fuel Delivery – the Carburettor**

The carburettor was invented in 1895 by Karl Benz and was still in use a hundred years later. Its basic function is to deliver the optimum mix of air and petrol to the

cylinder prior to combustion. Referring to Figure 6.5, the basic operating principle is as follows [8]:

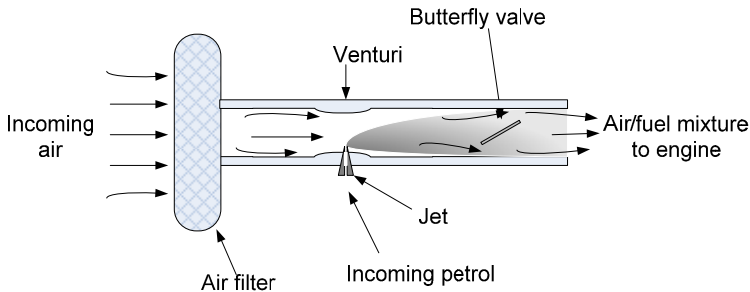

**Fig. 6.5** The basic carburettor

1. When a piston descends in the cylinder of an engine in the induction cycle, the inlet valve is open. This sucks in a volume of air/fuel mixture roughly equal to the displaced volume of the cylinder.
2. This action pulls in air through a filter and into the body of the carburettor. This is in the form of a Venturi tube in order to accelerate (and hence reduce the pressure) of the incoming air. The tube also contains a butterfly valve and a fuel jet. The butterfly valve, which determines the volume of the air flow, is connected to the accelerator pedal and is the means by which the driver controls the output of the engine and hence the speed of the car.
3. As the air flows past the jet at reduced pressure, it draws in fuel which divides into a spray of small droplets and mixes with the air (an aerosol)<sup>2</sup>. The fuel is supplied from a reservoir built into the body of the carburettor, the level of which is controlled by a float.

In the simplest form of carburettor, the proportions of the air/fuel mixture are determined by the jet diameter and its position in the air flow. This works reasonably well for steady power output at high engine speeds, though there are problems at other times:

- When the engine is cold the mixture needs to be much richer in order to get the engine to start.
- When the engine is ticking over at low speed, the air flow through the venturi is not sufficient to produce adequate fuel flow.
- During sudden acceleration of the car, the air can gain speed quicker than the heavier fuel producing a *lean* mix when a *rich* one is required.

Over time, the mechanical complexity of carburettors was increased in order to address these problems and to attempt to produce an optimum mix for all conditions. One such refinement is the variable choke carburettor where a damped

<sup>2</sup> The same principle as is used in a scent spray

piston rises and falls in the Venturi tube in an attempt to keep the speed of air flow across the jet constant [9]. At the same time, a tapered needle connected to the piston moves in and out of the jet, altering its effective diameter. In addition, some carburettors use a pump to boost fuel flow during rapid acceleration.

The problem of cold starting was resolved by means of a *choke* which simultaneously reduces air flow and increases fuel flow. For many years, these were hand operated, but eventually became automatic based on some kind of temperature sensor.

It is clear that the carburettor evolved to become a relatively complex and expensive piece of precision mechanical engineering. However, even in its most advanced form, it could not deliver the precision of fuel metering required to meet the demands of the modern car engine. This is also the case for a new carburettor. Older carburettors, where the needles and jets have been subjected to wear or poor adjustment, present even greater problems. Only an electronic fuel injection system can consistently deliver adequate fuel control in terms of performance, economy and environmental emissions.

## 6.4 The Mechatronic Solution to Engine Management

The first component to be replaced by mechatronics was the troublesome contact breaker points. From the 1970s onwards, these were replaced by a non-contact sensor inside the distributor that consisted of a rotating toothed armature (one tooth for each cylinder) that induces a signal from an electromagnetic transponder each time a tooth passes in front of it [7]. This signal was then sent to an electronic ignition control unit that triggered the firing of the coil and hence the spark. This simple innovation produced a stronger and more reliable spark and removed the need for the replacement and maintenance of points. At this stage, the mechanical centrifugal and vacuum advance systems remained.

The real revolution came in the mid-1980s when advances in electronic fuel injection and microprocessor technology enabled complete control over both ignition and fuel delivery to be contained within a single *Engine Control Unit* (ECU). This allows for a much clearer separation between sensing, processing and actuation in accordance with mechatronic principles. Both the distributor and the carburettor have now become redundant [6, 10].

### 6.4.1 Sensors

*Crankshaft and camshaft sensors* generally consist of toothed wheel armatures passing an electromagnetic Hall Effect sensor. By counting the pulses, the ECU can evaluate firstly engine speed in rpm, and secondly, the actual current position of the pistons and the stage in the four-stroke cycle. The armatures generally

contain a missing tooth so that the ECU can identify this and synchronise with a specific piston position. Because the crankshaft rotates twice within each four-stroke cycle and it is important for the ECU to know the current stage of the cycle, some indication is also required from the camshaft as to which spark plug is about to fire.

A *knock sensor* is essentially a microphone fitted to part of the engine block to listen for the distinctive sound of engine knocking, indicating that the spark is too far advanced. The microphone is associated with a bandpass filter to identify the relevant knocking frequencies and inform the ECU.

A *Lambda* or *oxygen sensor* is placed in the exhaust system to measure any unburnt oxygen in the waste gasses. They are primarily used to control the air/fuel mix ratio as richer fuel mixes tend to burn quicker, requiring less ignition advance. A lambda sensor contains a ceramic layer which produces a current in the presence of excess oxygen. This current can then be detected by the ECU. They only work effectively when hot, and hence the ECU may be told to ignore the output when the exhaust system is cold. In order to reduce the waiting time, some sensors are fitted with heaters and are known as *Heated Exhaust Gas Oxygen sensors* or HEGOs.

A *throttle position sensor* is a simple rotary potentiometer usually connected to the end of the butterfly valve in the air induction system. Knowing the degree to which the valve is open gives the ECU a good indication of the driver's intentions. By looking at direction of movement and rates of change of the valve, the ECU can determine if the vehicle is accelerating, decelerating or cruising; all of which influence ignition timing and fuel ratio.

The *mass air flow sensor (MAF)* is contained in the air induction system and provides information on the mass of air entering the engine which is obviously key to determining the appropriate amount of fuel to inject. The sensor consists of a heated wire element that is maintained at constant temperature in the varying air flow. The current required to maintain this temperature is directly proportional to the mass of air flowing.

Earlier sensors measured *volume* of flow, but as the density of air reduces with temperature, additional temperature information was required to calculate the mass of air with sufficient accuracy.

A *water temperature sensor* allows the ECU to detect a cold start and hence enrich the fuel. The normal fuel mixture is then adopted when the temperature reaches a pre-set value.

## 6.4.2 Actuators

Ignition coils still provide the high voltage for the spark plugs, but in the absence of a distributor, modern systems often use individual coils for each plug or pair of plugs. The triggering signal comes directly from the ECU.

Fuel Injectors add a spray of fuel through a nozzle to the incoming air flow in order to achieve the appropriate air/fuel mix ratio. Current practice is to use one injector per cylinder, all of which are fed by a constant-pressure fuel line. Variation in the amount of fuel added is determined by very precise control over the time that the injector valve is opened on each induction cycle. The opening of the valve is affected by a signal from the ECU that powers a solenoid within the injector. Closure is by means of a return spring and the fuel line pressure.

### 6.4.3 Processing

The ECU generally takes the form of a module such as that of Figure 6.6 within the engine compartment. The module contains:

- all the electronics for receiving and conditioning the signals from the sensors;
- a powerful processor for interpreting the signals and determining the outputs;
- output circuits and amplifiers for driving the ignition coils and fuel injectors.

In addition, the ECU will contain a fault memory that can be read when the vehicle is serviced. The essence of determining the most appropriate system outputs is the reading of values from look-up tables or *maps* such as that of Table 6.1.



**Fig. 6.6** A typical 'black box' *Engine Control Unit* (ECU) module

**Table 6.1** A portion of the fuel map for a high-revving motorcycle engine

<b>Fuel Map</b>								
	Throttle Position							
RPM	0.00	4.00	7.00	11.00	16.00	22.00	29.00	
500	3.06	3.65	3.65	4.64	4.80	5.00	5.14	
1000	2.08	2.78	3.34	3.34	4.45	4.85	5.12	
2000	2.07	2.78	3.34	3.34	4.45	4.85	5.12	
3000	1.85	2.78	3.34	3.34	4.45	4.85	5.12	
4000	1.75	2.62	3.15	3.15	4.20	4.58	4.83	
4500	1.75	2.62	3.15	3.20	4.25	4.71	5.05	
5000	1.75	2.62	2.60	2.97	4.04	4.43	4.73	
6000	1.72	2.57	2.11	2.64	3.33	3.77	4.14	
6500	1.63	2.44	2.31	2.64	3.41	3.80	4.11	
7000	1.61	2.42	2.59	2.76	3.62	4.00	4.27	
7500	1.60	2.40	2.72	2.43	3.37	3.80	4.15	
8000	1.58	1.90	1.90	2.09	3.13	3.61	4.03	
9500	4.67	5.08	5.21	5.26	5.10	5.32	5.19	
10000	4.67	5.08	5.27	5.33	5.29	5.45	5.19	

Injector opening time (μs)

Aftermarket ECUs that are reprogrammable are available for car developers and in this case, the engine maps will be stored on a separate EPROM chip within the ECU. Such ECUs are provided with software that can be used in conjunction with a laptop to tune the engine while running. The basic tables are the *ignition map* and the *fuel map*. In both cases, one axis of the map represents the speed of the engine (rpm) and the other some indication of engine load. Table 6.1 shows an example of the fuel map for a motorcycle engine. In this case, the vertical axis is rpm and the horizontal axis represents the percentage of throttle opening. The figures in the cells indicate the time in microseconds that the injector should remain open for.

The data in the above table is often represented as a 3D surface, as shown in Figure 6.7, which is clearly the origin of the term engine ‘map’. Figure 6.8 then shows a typical architecture for an engine management system. At the heart is a powerful processor such as the Motorola MPC 500 32-bit chip [11].

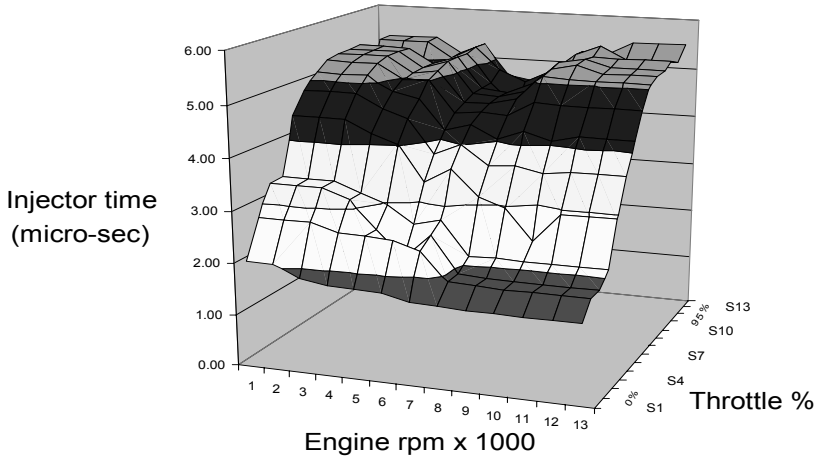

Fig. 6.7 3D surface fuel map

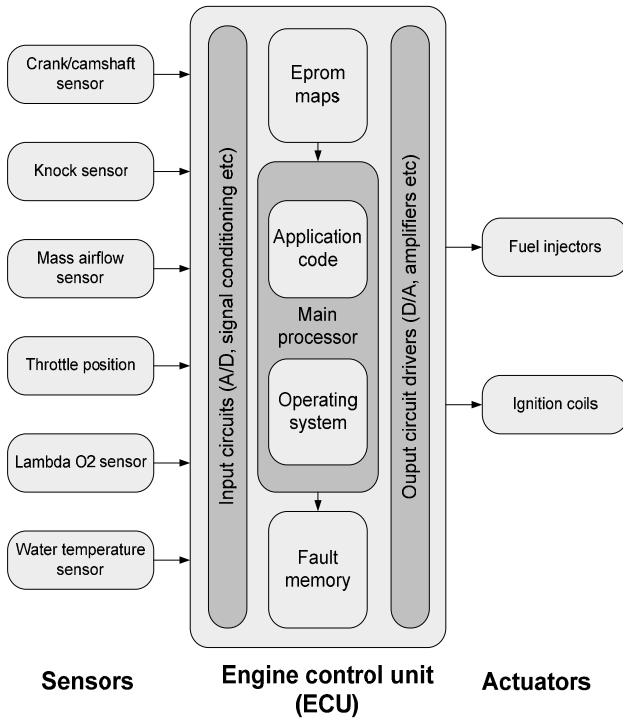

Fig. 6.8 Engine management system architecture

## 6.5 Anti-lock Braking System (ABS)

Anti-lock Braking Systems (ABS) are sometimes called *anti-skid* brakes. The systems use mechatronic technology to individually control the four brakes on a vehicle, which would clearly be impossible for a human driver. The main purpose is to control the stability of a vehicle and maintain steering response either during very hard emergency braking or for normal braking under wet or icy conditions. The braking distance required to bring a vehicle to a stop can also be reduced, but this is really a secondary bonus effect of the system.

The ABS employs a mechatronic system comprised of wheel speed sensors, electro-hydraulic valves and a central processing unit. The system constantly monitors the rotational speed of all four wheels and when it detects one wheel slowing down faster than all the others, it reduces the braking force at that wheel by blocking or even reversing the flow of hydraulic fluid to the wheel. It is thus a system which if it malfunctioned, is capable of immobilising the entire brake system of the vehicle. For this reason, it must clearly be regarded as safety critical.

### 6.5.1 Background to the Theory of Braking [2]

When a vehicle moves at constant speed, the distance moved by the vehicle in one revolution of a wheel is, as expected, equal to the circumference of the wheel. However, when the vehicle is accelerating or braking, this simple relationship does not apply. There is relative movement between the tyre tread and the road surface known as “slip”. When braking, it is known as “brake slip”. Under normal braking, the amount of brake slip increases linearly as the braking force increases. This is known as the stable region. However, under hard braking when the brake slip reaches a value of about 20%, the braking force stops increasing and thereafter actually decreases. This is the unstable region.

When a wheel is fully locked (brake slip = 100%), the effective coefficient of friction between the tyre and the road is reduced to about 80% of its maximum value. Wet road conditions exaggerate the effect.

ABS endeavours to keep the slip in the stable region for all wheels at all times. It does this by monitoring the relative speeds of all the wheels and comparing them with an average reference value obtained from diagonally opposite wheels. When it detects a wheel slowing down faster than it should, it momentarily holds or releases the brake pressure on that wheel.

When a wheel enters the unstable region, the peripheral deceleration increases rapidly and this can be detected by the ABS controller. The normal peak coefficient of friction between a modern tyre and the road is about 1.0. This means that a vehicle can decelerate (and accelerate) at a maximum of about 1 g. Of course, if there was no brake slip, the perimeter of the wheel would also decelerate at about 1 g. However, a wheel can lock within only 110 ms. For a car travelling at



60 mph, this represents a deceleration of about 20 g and hence can easily be detected by a fast processor. This is shown in Figure 6.9.

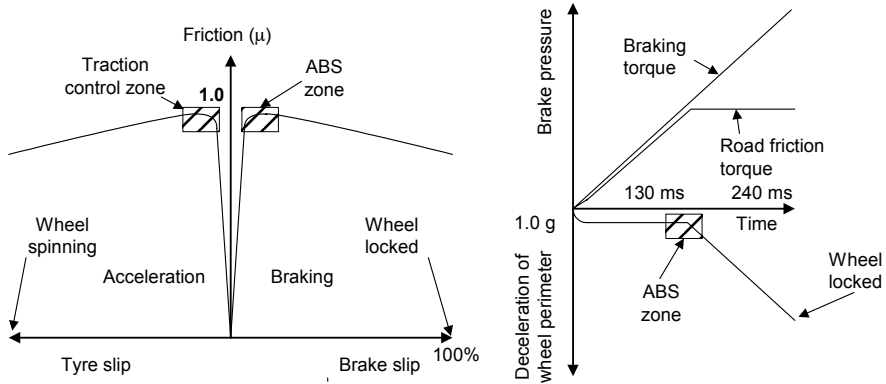

**Fig. 6.9** Brake slip

ABS systems achieve the above by means of complex software logic (rules). A typical sequence for dry braking is described below:

*Phase 1* – The wheel peripheral deceleration moves beyond the defined threshold ( $-a$ ) and the ABS valve is instructed to “maintain brake pressure”.

*Phase 2* – The wheel perimeter velocity continues to reduce until it falls below a reference value which is based on extrapolation of previous vehicle speed. The valve shifts to “pressure release” mode.

*Phase 3* – The brake pressure drops and the deceleration rate of the wheel also drops until it again rises above the threshold value ( $-a$ ). The brake pressure is then maintained.

*Phase 4* – The wheel actually starts to accelerate again and eventually reaches a certain threshold ( $+A$ ).

*Phase 5* – The brake pressure is allowed to increase again until the acceleration again falls below the threshold ( $+A$ ).

*Phase 6* – The brake pressure is maintained until the acceleration drops to the lower threshold ( $+a$ ).

*Phase 7* – The wheel is now “underbraked” so the pressure is slowly ramped up until the deceleration drops below ( $-a$ ).

*Phase 8* – The cycle is repeated from phase 3 until normal braking is detected.

### 6.5.2 ABS Components

#### Hydraulic Control Valves – One for Each Wheel

These are 3-position valves that employ an electrical solenoid to move between positions. The first position allows fluid to pass between the brake master cylinder and the wheel brake cylinder in the normal way (see Figure 6.10). The second position (50% of maximum current) prevents movement of fluid between the brake master cylinder and the wheel brake cylinder. The third position (maximum current) connects the wheel brake cylinder to the fluid return line and with the aid of a pump, can reduce the brake pressure at the wheel.

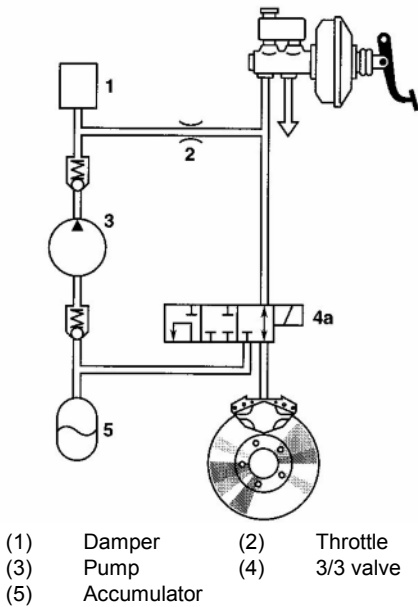

Fig. 6.10 ABS hydraulic components [2]

#### Wheel Speed Sensors

The wheel speed sensors consist of an electromagnetic proximity sensor fixed in a stationary position to the wheel hub. The sensor is positioned about 1 mm from a rotating toothed ring which is connected to the moving wheel shaft. Each time a tooth passes the sensor, a signal is sent to the ECU.

The Electronic Control Unit

This is configured as shown in Figure 6.11 and comprises the following major subsystem:

Input circuit – conditions the signals from the wheel speed sensors and forwards them to one of two microcontrollers.

Microcontrollers – Two identical but separate integrated circuits. Each one connected to two diagonally opposite wheels. They process the wheel speed signals to decide on the appropriate ABS action. Commands are sent to an output circuit.

Output circuits – In response to commands from the microcontrollers, two-stage output circuits use power transistors to amplify the signals to provide enough current to energise the solenoids on the hydraulic valves.

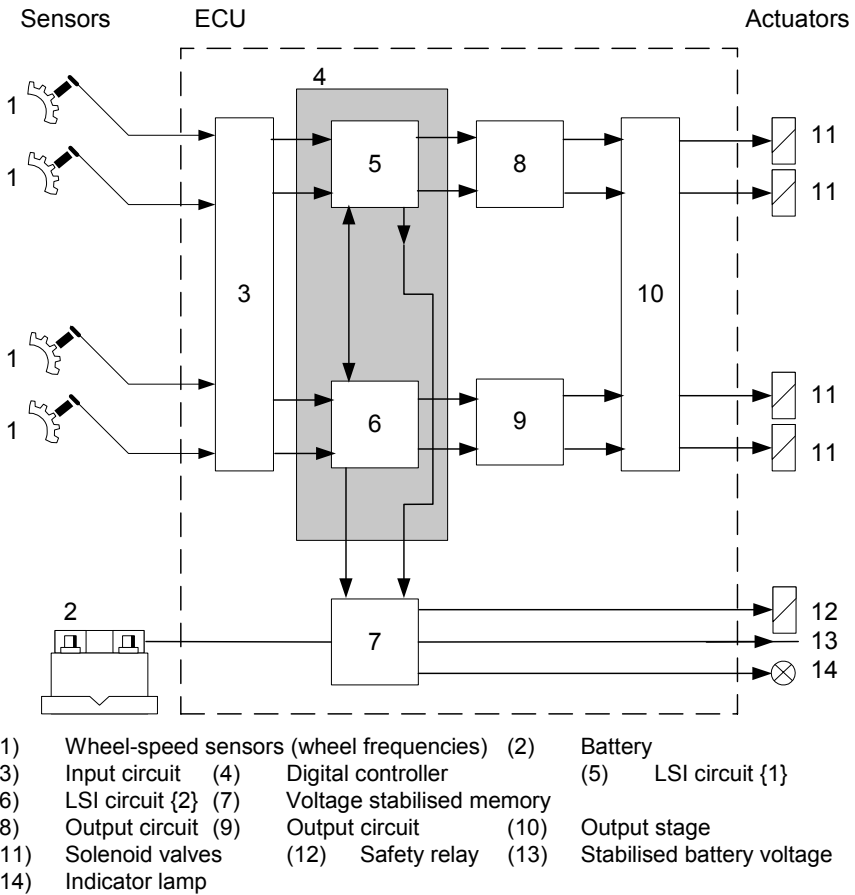

Fig. 6.11 ABS control unit [2]

### 6.5.3 ABS Diagnostics

Partly because of the safety critical nature of ABS, the system contains extensive diagnostic functionality which operates at several stages of the vehicles operation:

- When first switching on the car ignition, the ABS controller will send signals to the four three-way valves and the wheel speed sensors. By monitoring the current consumed, the controller will be able to predict whether the hydraulic valve spools have stuck or if either a short or an open circuit exists in a component.
- In general, if a defect is discovered, the ABS system will be disabled and a warning light will be illuminated on the dashboard.
- When first pulling away, the output from the four wheel speed sensors is monitored and a reasonableness check applied.
- All defects and spurious behaviours are recorded in a fault memory within the controller for downloading when the vehicle is serviced.

## 6.6 Conclusions

Consideration was given to three automotive mechatronic systems. The first two, *electronic ignition* and *electronic fuel injection*, are integrated within the engine management system. They provide examples of how the superior performance of mechatronics displaced traditional (and relatively unreliable) electrical and mechanical systems. The third, the *anti-lock braking system (ABS)*, is an example of mechatronics offering a new opportunity to improve the controllability and hence safety of vehicles. This is typical of the mechatronic process. It first supplants traditional technologies and then offers vastly increased functionality because of the flexibility afforded by software control.

## References

1. Schwarz H *et al.*, (1995), *Automotive Electric/Electronic Systems*, Robert Bosch GmbH
2. Siegert E *et al.*, (1999), *Driving safety systems*, Robert Bosch GmbH
3. [www.kunhadi.org/main/?q=node/74](http://www.kunhadi.org/main/?q=node/74)
4. [www.vdo.com/-+archive+/-e-corner/technology-behind-ecorner/technology-behind-e-corner.htm](http://www.vdo.com/-+archive+/-e-corner/technology-behind-ecorner/technology-behind-e-corner.htm)
5. [www.gill.co.uk/products/digital\\_ignition/Introduction/6\\_4stroke.asp](http://www.gill.co.uk/products/digital_ignition/Introduction/6_4stroke.asp)
6. Banish G, (2007), *Engine Management – Advanced Tuning*, Brooklands Books Ltd.
7. [www.familycar.com/Classroom/ignition.htm](http://www.familycar.com/Classroom/ignition.htm)
8. [www.iop.org/EJ/article/0305-4624/10/1/304/ptv10i1p20.pdf?request-id=5559c3fd-a4b0-4320-865b-c8bf9f4ad8eb](http://www.iop.org/EJ/article/0305-4624/10/1/304/ptv10i1p20.pdf?request-id=5559c3fd-a4b0-4320-865b-c8bf9f4ad8eb)

9. [www.zparts.com/zptech/articles/mal\\_land/ml\\_sucarb2/images4/SUcarb\\_111601b.htm](http://www.zparts.com/zptech/articles/mal_land/ml_sucarb2/images4/SUcarb_111601b.htm)
10. Hartman J, (2003), How to Tune and modify Engine Management Systems, Motorbooks International
11. [www.motorola.com/mediacenter/news/detail.jsp?globalObjectId=767\\_523\\_23&page=archive](http://www.motorola.com/mediacenter/news/detail.jsp?globalObjectId=767_523_23&page=archive)

# Chapter 7

## Multi-mode Operations Marine Robotic Vehicle – a Mechatronics Case Study

Daniel Toal, Edin Omerdic, James Riordan and Seán Nolan<sup>1</sup>

### Acronyms and Abbreviations:

AUV	Autonomous Underwater Vehicle
DGPS	Differential Global Positioning System
DOF	Degree of Freedom
DVL	Doppler Velocity Log
GAPS	Ultra Short Base Line made by ixSea
GPS	Global Positioning System
GUI	Graphical User Interface
HT	Horizontal Thruster(s)
INS	Inertial Navigation System
INSS	Irish National Seabed Survey
LLC	Low Level Controller(s)
MMRRC	Mobile and Marine Robotics Research Centre
MPPT Ring	Multi-Purpose Platform Technologies for Subsea Operations
NI-PSP	National Instruments Publish-Subscribe Protocol
PHINS	Inertial Navigation System made by ixSea
RIO	Reconfigurable Input-Output
ROV	Remotely Operated Vehicle
SVP	Sound Velocity Probe
UDP	User Datagram Protocol
USBL	Ultra Short Base Line
UUV	Unmanned Underwater Vehicle
VR	Virtual Reality
VT	Vertical Thruster(s)
VUL	Virtual Underwater Laboratory

---

<sup>1</sup> University of Limerick, Ireland

## 7.1 Introduction

This chapter details the development of a novel, multi-mode operation marine robotics vehicle designed using mechatronic principles for operational flexibility in high-resolution near-seabed surveys from shallow inshore waters out to the continental shelf edge. The vehicle can be operated in surface-tow mode or as a thrusted pontoon. With the buoyancy module released, the vehicle becomes neutrally buoyant and is operated as a survey class remotely operated vehicle (ROV) depth rated to 1,000 m.

Special features of the system include:

- deployment interoperability for small inshore boats and larger research vessel;
- fault tolerant thruster control;
- novel high frequency short range sonar;
- onboard computer control enabling real-time disturbance reaction;
- topside augmented reality system support.

The background which motivated the vehicle development is presented, including the parallel development of vehicle models and simulations with concurrent physical vehicle design construction and testing. The associated development of the virtual reality/augmented reality instantiation in tandem with the physical vehicle design and construction has had many benefits for the overall system design, optimisation, flexibility and robustness.

Based on the experience gained in previous projects, the challenges met, the solutions developed and the inherently high costs associated with marine technology and offshore operations [1–4], work started on the design and development of a flexible multi-mode of operation survey class thrusted pontoon/ROV as part of the MPPT Ring project [5]. This is aimed at developing multi-purpose platform technologies for subsea operations, which will in turn serve as a generic solution in addressing the following challenges:

- easy integration of survey equipment, efficient planning and mission simulation;
- training of ROV pilots;
- fault-tolerant control of ROVs;
- enhanced operator environment and survey tools during mission execution;
- offline analysis of acquired data.

The MPPT Ring (see Figure 7.1) is implemented as a hardware/software platform and web service to enable product demonstration both offline (e.g., in a lab or trade show) and online (for run-time survey application).

This duality of operations opens new frontiers for the applications of modern control, modelling and simulation tools in marine technology development. It provides a framework for researchers to develop, implement and test advanced control algorithms in a simulated virtual environment under conditions very similar to the real-world environment. Recent advances in computer technology

have made it possible to perform data acquisition, processing, analysis and visualisation with high speeds previously considered infeasible. A review of activities in the field of hardware-in-the-loop simulators is given in Ridao *et al.* [6].

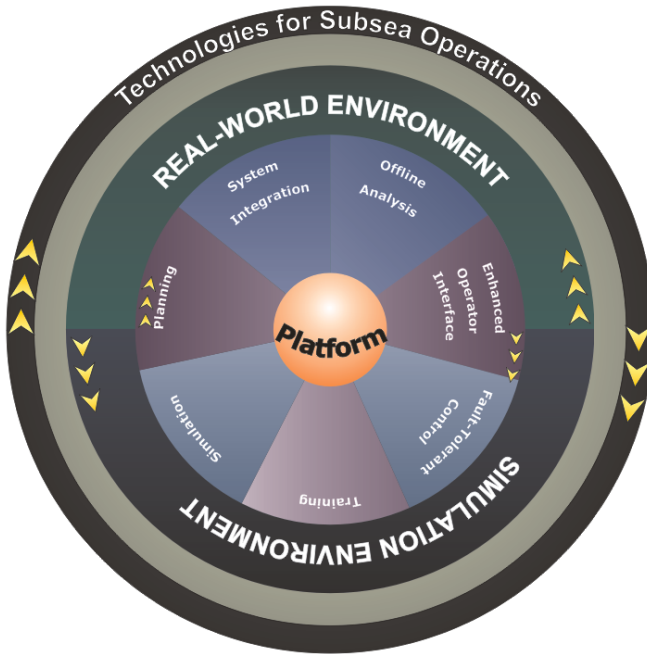

Fig. 7.1 MPPT Ring

## 7.2 MPPT Ring System Overview

### 7.2.1 Main Features

The main features of the MPPT Ring are:

- signal-level compatibility between simulated and real-world environments;
- 3D real-time visualisation of navigation data;
- real-time vessel and sonar simulators;
- advanced, flexible fault-tolerant control system with autotuning capabilities;
- open architecture for rapid control prototyping and hardware-in-the-loop development;
- set of aiding tools for ROV pilot;
- survey planning and operation tool.



Other system properties are highlighted in the following:

### *System Integration*

- Check connection and make system integration before mission execution.
- Detect and resolve problems in advance.
- Find optimal positions for onboard equipment.
- Make fast connection with ship and ROV resources and save costly ship time.

### *Planning*

- Build complex underwater scenarios using an expandable database of objects (ROV and ship models), structures and custom components (moorings, buoys, etc.).
- Prepare mission plan, including routes, trajectories and way points.
- Generate marketing “proof of concept” visualisations.

### *Simulation*

- Simulate run-time behaviour in normal and critical situations under disturbances (waves, currents, umbilical effect) using full 6 DOF real-time simulators.
- Develop and test advanced fault-tolerant control system with autotuning features.
- Use hardware-in-the-loop to evaluate the performance of embedded controllers.
- Simulate system response to different faults (thruster faults, leakage in the wet bottle).

### *Training*

- Provide real-feel training without exposing personnel and equipment to hazards while simultaneously saving expensive ship-based training.
- Train pilots to control the vehicle in normal and harsh conditions, including strong currents, waves, thruster faults and system errors with no risk of system damage or loss.
- Provide interaction with dynamic objects using standard input interfaces.

### *Fault-tolerant Control*

- Provide optimal and robust vehicle control in the fault-free case, which minimises control energy cost function.
- In faulty cases, detect, isolate and accommodate faults by distributing control energy among operable thrusters and continue missions with minimum loss of performance and manoeuvrability.

- Using a set of aiding tools, allow operators to be more concentrated on other tasks.

#### *Enhanced Operator Interface and Auto-enhanced Survey Execution*

- Expand existing operator display with real-time 3D VR visualisation.
- Create virtual view points and view the VR scene from different angles.
- Eliminate decision uncertainties due to bad visibility and harsh weather conditions.
- Log run-time data for later replay and analysis.
- Synchronise sonars and ship auto-tracking based on real-time captured digital terrain.

#### *Offline Analysis*

- Replay the mission looking at the scenario from any angle or viewpoint.
- Use advanced features of real-time simulators and statistical tools to calibrate instruments and improve accuracy of sonar images.
- Determine factors that need to be improved to make future missions even better.

The MPPT Ring thus has three innovative components which can function in a stand-alone mode and/or be used in a fully integrated system. These are:

1. real-time simulator for high-resolution sonar mapping of survey scale environments;
2. integrated ship and ROV operations assessment, planning, and execution tool;
3. offshore operations planning and real-time operation control tool.

### ***7.2.2 The Virtual Underwater Laboratory***

These developments are supported by the implementation of the Virtual Underwater Laboratory or VUL [7]. This, a crucial component of the MPPT Ring, is a mixed hardware/software augmented reality marine operations support tool designed to resolve the weak points associated with traditional survey mobilisation and operations strategies and to simplify overall system integration.

The VUL uses an open architecture, providing a framework for researchers to develop, implement and test advanced control algorithms in a safe, simulated environment before tests are performed in a real-world environment. The signal-level compatibility between the simulated and real-world environment provides the opportunity for rapid control prototyping and hardware-in-the-loop development techniques to be used in system design.

### 7.2.3 Architecture and Implementation

Interconnection between the VUL and existing ship and ROV resources, real-world environment is shown in Figure 7.2. In the simulated environment, real-world components from the ship (GPS1, GAPS) and the ROV (PHINS, external sensors, power lines and leak detectors) are replaced with hardware/ software simulators, as shown in Figure 7.3. More details about the roles, input/output interface and function of the main hardware VUL components can be found in Omerdic *et al.* [7].

All simulators are synchronised with real-time. Full 6 DOF vessel dynamic models are implemented, including thruster DC-motor dynamics with non-linearities such as saturation, slew-rate limiter, friction, non-linear propeller load and so forth. Different components of ship and ROV simulators are simulated as parallel loops executed with different speeds depending on the dynamics of components. Payload imaging sonars are simulated remotely on a dedicated PC. The inputs to and outputs from the virtual instruments (simulators) are compatible with corresponding real-world instruments at the signal level. In this way, all communication delays and latencies are present during the control design stage which then provides a framework to support the design of robust control systems in a realistic environment.

All software is implemented in LabVIEW, Matlab and Visual Studio C++. Data (outputs of individual components) are bundled into clusters and transmitted using network-published shared variables based on the National Instruments Publish-Subscribe Protocol (NI-PSP). The NI-PSP protocol uses less network bandwidth and is more efficient than TCP/IP for the given requirements of the NI-PSP protocol. However, unlike the User Datagram Protocol (UDP), the NI-PSP protocol guarantees delivery by implementing an additional layer of functionality on top of the raw UDP structures.

A simulation block diagram including ROV dynamics and kinematics is given in Figure 7.4. If desired, system states can be “contaminated” with sensor noise. Hence, in the simulated environment, two types of navigation data are available: noise-free and noisy data (states). However, only noisy data are available in the real-world environment. Real-time access to noise-free and noisy data in simulation mode provides tools to investigate the influence of sensor error measurements on the performance of the overall control system and to assess the quality of side-scan and multibeam imagery [8, 9].

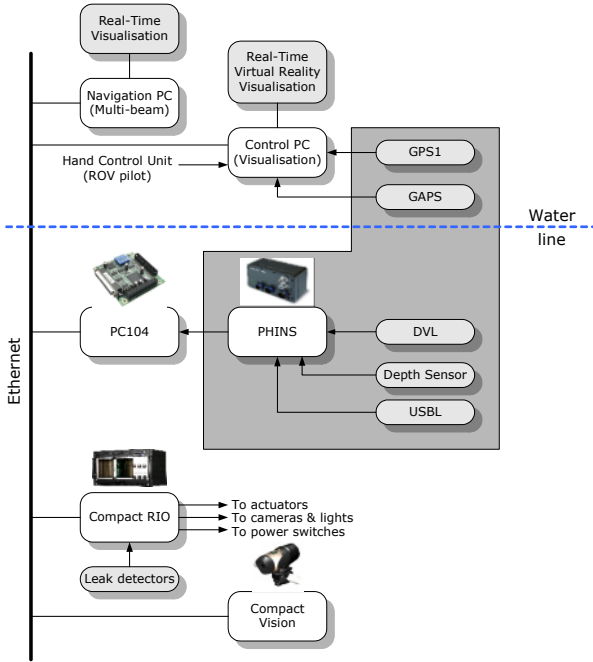

Fig. 7.2 VUL in real-world environment

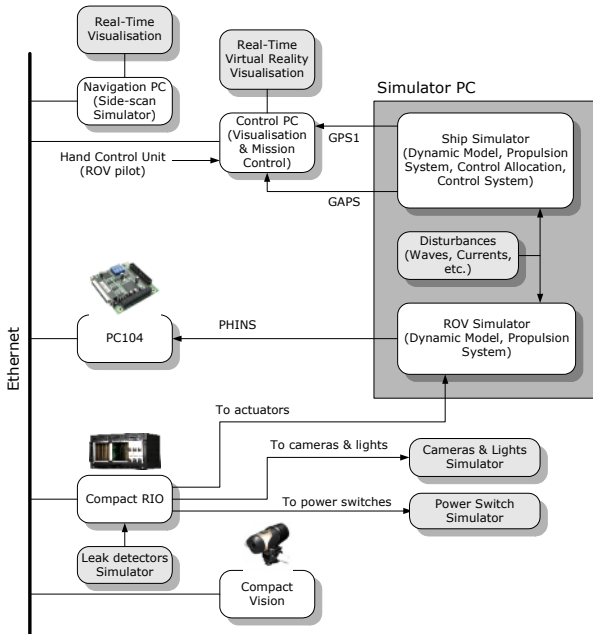

Fig. 7.3 VUL in simulated environment

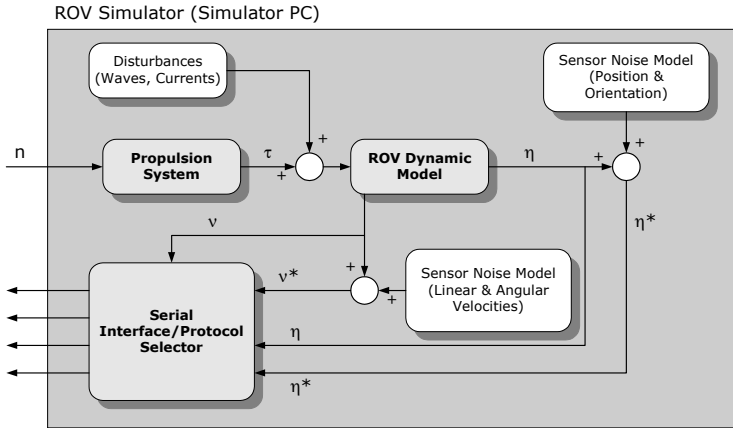

Fig. 7.4 ROV dynamics and kinematics simulation loop

Table 7.1 Implemented serial output protocols

ASCII output protocols	Binary output protocols
Gyrocompass	DORADO OUT
Gyrocompass II	Simrad EM
HYDROGRAPHY	Navigation Short
INDYN	Control
OCTANS Standard	
PHINS Standard	
POSIDINIA 6000	

A serial output interface is used to transform noise-free and noisy states into INS-compatible messages which are sent through available communications ports. Currently, seven ASCII and four binary output protocols have been implemented, as indicated in Table 7.1.

### 7.2.4 Imaging Sonar Simulator

While mathematical models to simulate the pertinent physical processes governing subsea acoustic imaging have existed for decades, to date, no instance of a PC based real-time sonar simulator has appeared commercially [10]. This is a direct result of the limited computational capacity of PC technology combined with both the massive scale of the oceanographic databases required to initialise and evaluate meaningful mission scenarios and the numerically intensive nature of acoustic simulation models. Capable of processing only a minute fraction of the acoustic transmission-reception cycle in real-time, an hour of simulation time may typically translate to one minute of real-time using current state-of-the-art acoustic

simulation technology [10]. Consequently, existing sonar simulation models operate in simple idealised environments and do not address the complexity of the environmental model or they operate offline.

Both instances represent significant drawbacks for the end user as the key issue with marine systems modelling and simulation is the capability to rapidly and exhaustively test the effectiveness of proposed methodologies in a realistic model of the underwater operating environment. For cost-effective sonar research, education, and offshore training applications, the ideal solution is a single integrated model with the requisite resolution and fidelity to accurately perform real-world representative simulation in real-time on commercial-off-the-shelf PC technology. Synthetic side-scan sonar imagery generated by simulator is shown in Figure 7.5.

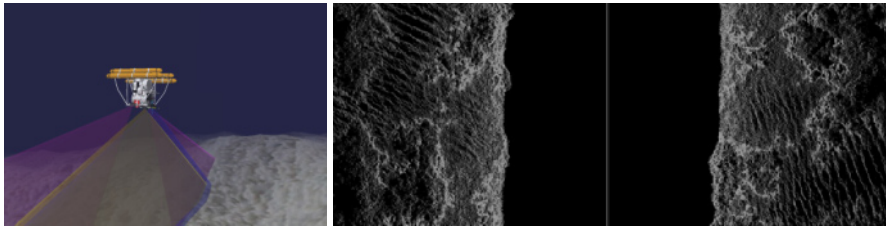

**Fig. 7.5** Synthetic side-scan sonar imagery generated by simulator

### ***7.2.5 Laboratory Configuration***

The laboratory interconnection of the VUL components is shown in Figure 7.6. Two VUL applications run in parallel on the control PC. The first is the Graphical User Interface (GUI) of Figure 7.7 for an ROV pilot using a joystick, keyboard and mouse for interaction with the GUI. The second is the Virtual Reality display of Figure 7.8, used to visualise a VR scene<sup>2</sup> in real-time, using measurements from virtual sensors (simulation environment) or real sensors (real-world environment). Figure 7.9 displays a part of the main screen of the ROV simulator. A part of the PC104 display is shown in Figure 7.10. This display is not available in the real-world environment. However, the PC104 can be accessed and remotely administered from the Control PC through the network using the remote administrator.

---

<sup>2</sup> Ship, ROV, ocean surface, seabed and so forth



Fig. 7.6 VUL – Overall lab setup

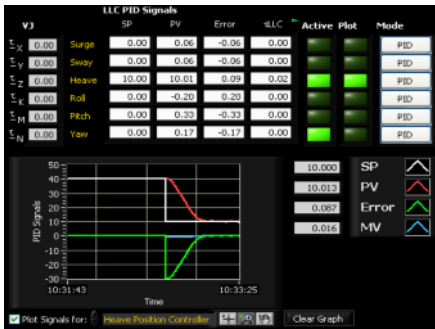

Fig. 7.7 VUL – GUI (Control PC)



Fig. 7.8 VUL – Virtual Reality display (Control PC)

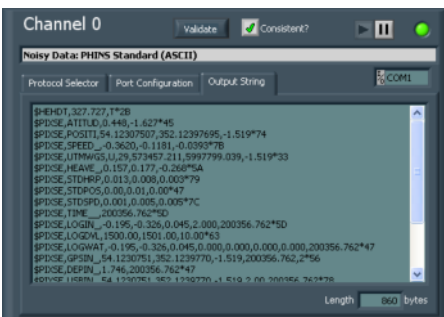
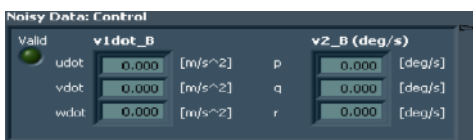

Fig. 7.9 VUL – ROV simulator (Control PC)



Fig. 7.10 VUL – PC104 shared data



## 7.3 University of Limerick (UL) Thrusted Pontoon/ROV

### 7.3.1 Base Vehicle

The Thrusted Pontoon/ROV is a multi-mode of operation vehicle. It can be operated on the surface (Figure 7.11) as a survey platform either towed (by an extra towing cable) or thrusted by 4 horizontal thrusters to allow surge, sway and

yaw which is useful in confined spaces or near hazards where a boat and tow cannot operate. It can also be operated as an ROV (Figure 7.12). In these various modes of operation, it is used in conjunction with an umbilical and associated winch; the umbilical carrying vehicle power, control and data from sensors and instruments.

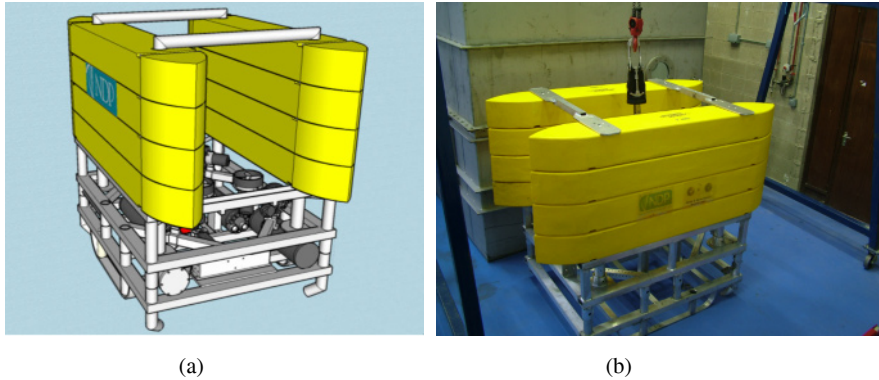

**Fig. 7.11** Model (a) and real vehicle (b) with surface operation buoyancy configuration – positively buoyant

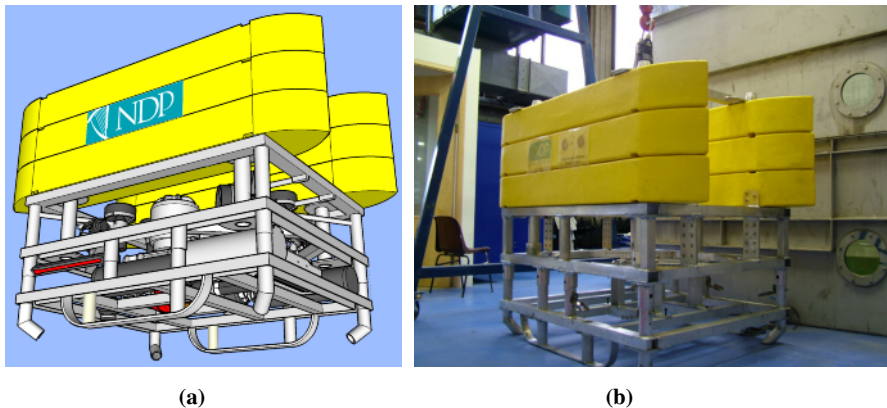

**Fig. 7.12** Model (a) and real vehicle (b) with ROV operation buoyancy configuration – neutrally or marginally positive buoyancy

In the surface-tow or surface thrust modes of operation, overall vehicle buoyancy is maintained strongly positive by 8 buoyancy modules mounted on the pontoon upper frame. While in surface-tow mode, a “Quick Release” arrangement allows the two top most buoyancy modules to be detached from the vehicle, reducing overall vehicle buoyancy to neutral or slightly positive. The vehicle can then be operated in ROV mode for submerged survey with control in six degrees of freedom (surge, sway, yaw, heave, pitch and roll). The syntactic foam buoyancy modules are depth rated to 1,000m, while all the other components



integrated on the vehicle including payload sensors are depth rated beyond 2,000m.

The vehicle is designed and constructed in modules. This is for ease of handling in inshore surveys on small boats with small crews and each component in this modular design (buoyancy modules, upper frame, lower tool skid, etc.) is kept to a two man dry weight lift. The upper frame mounts eight thrusters – four horizontal and four vertical. The lower tool skid frame carries the payload sensors.

### ***7.3.2 High-resolution Imaging Tool Skid***

The sensor systems integrated on the survey tool skid include: black and white and colour video cameras, Reson 7125 multibeam sonar, Tritech side-scan sonar and an ixSea fibre gyro-based navigation system with Kalman filter and aiding sensors (RDI DVL, Digiquartz pressure depth sensor). When deployed off research vessels in deep operations, a transponder for USBL acoustic positioning is also integrated on the vehicle to give the best possible navigation/positioning up to target depths of 1,000 m. The multibeam and side-scan sonar pings are controlled centrally to avoid the instruments' transmission reception cycles interfering with each other [11].

### ***7.3.3 Onboard Electronics and Computer Control***

Electronics and controllers (two PC104 controllers and National Instruments Compact RIO system) are included within wet bottles on the vehicle rather than on the topside. This facilitates real-time control loop operation without the latency of the communications channel/network to the surface. All parameters are monitored topside and command level instructions communicated to the onboard controllers.

Another advantage of this onboard controller setup is that it facilitates autonomous vehicle development experimentation for near-intervention scenarios without the risk of losing expensive AUV systems. AUV development testing can thus be performed on the vehicle while tethered and operations can be monitored from the surface.

Electronics, controls and sensor systems are integrated across four computer networks for reasons of separation of the time critical control functionality, payload sensor system control and data logging and high bandwidth imaging sonar requirements. These networks are as follows:

*Net1* – Reson Multibeam Network (Bespoke). The 7125 multibeam system as supplied calls for a dedicated network to provide deterministic latency for fusion of sonar imagery and motion reference data.

*Net2* – Control and Navigation Network (100BaseT): Devices on this network include National Instruments Compact RIO system for low-level control and I/O interface with devices (leak detectors, cameras and actuators), National Instruments Compact Vision system and a PC-104 for control.

*Net3* – Survey Network (1000BaseT): Devices on this network include: PC-104 for sensors (video and sonars); 8 x serial I/O channels; 4 x video channels for ROV composite/HD cameras.

*Net4* – Video Network Option: 4 x video channels for extra science payload camera expansion.

### ***7.3.4 Fault Tolerant Thruster Control***

A hybrid control allocation approach [12] is implemented inside the Control Allocation Express VI (Figure 7.13). In the fault-free case, optimal control allocation is guaranteed for all possible command inputs since the hybrid approach for control allocation finds the exact solution on the entire attainable command set. This solution is optimal in that it minimises a control energy cost function, the most suitable criteria for underwater applications.

In fault situations, the fault diagnosis part of the system immediately detects and isolates any fault in a thruster using fault detection units and delivers knowledge about faults in the form of a fault indicator vector. The fault accommodation part of the system uses this vector to accommodate the fault and eventually switch off the faulty thruster. At the same time, control reallocation is performed by redistribution of control energy among remaining operable thrusters such that the mission can be continued with a minimal loss of control performance. All inputs to the Control Allocation Express VI are normalised to standard intervals. Depending on user-defined settings inside the dialog box, the outputs (actuator settings) can be compensated for non-symmetrical propeller T-curves and adapted (scaled and/or rounded, if necessary) to meet requirements of thruster input interfaces. Degree of usage of each thruster is controlled by sliders HT (VT) Saturation Bounds. The position of these sliders is determined by the ROV pilot or fault diagnosis system depending on the state of thrusters (healthy, partial fault or total fault).

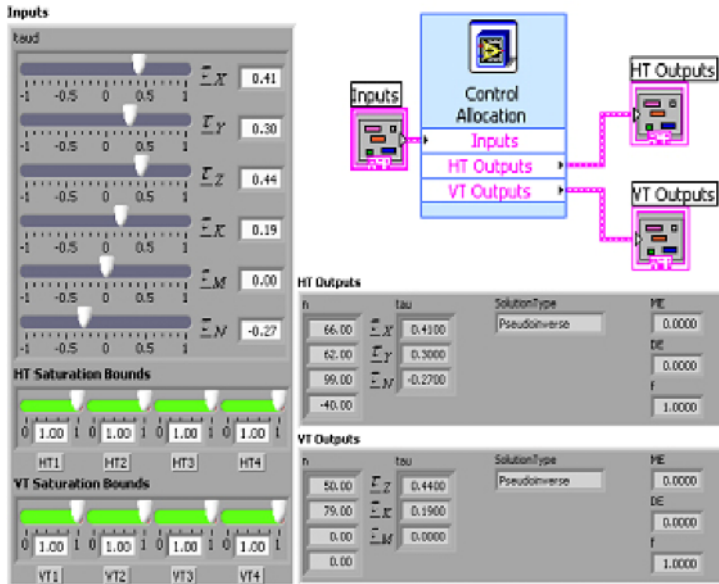

Fig. 7.13 Control Allocation Express VI

### 7.3.5 Autotuning of Low-level Controllers

Between successive ROV missions, it is likely that some onboard instruments/sensors/equipment will be added/removed/replaced, leading to changes in the dynamic properties of the ROV (mass, moments of inertia, drag properties, etc.). Controllers optimally tuned for a particular vehicle configuration will not give the optimal performance in the case of a change in configuration.

The autotuning of Low-Level Controllers (LLCs) is an advanced feature of the control system, yielding optimal controller performance regardless of configuration changes. It is recommended that the autotuning is performed at the beginning of a mission. Autotuning algorithms described by Miskovic *et al.* [13] have been expanded for six DOF controllers. The autotuning process is performed for each LLC (surge, sway, heave, roll, pitch, yaw) separately and in the case of the last four DOFs, involves the following steps:

1. generate self-oscillations;
2. wait for transient stage to be finished;
3. measure amplitude and period of steady-state oscillations;
4. find new values of controller gains using tuning rules.

A novel set of tuning rules for underwater applications has been developed which provides the optimal performance of low-level controllers in the case of

configuration changes and presence of disturbances (waves and ocean currents). Autotuning of the Heave LLC is shown in Figures 7.14 and 7.15. The ROV is oscillating (moving up and down) around a set point of 30 m.

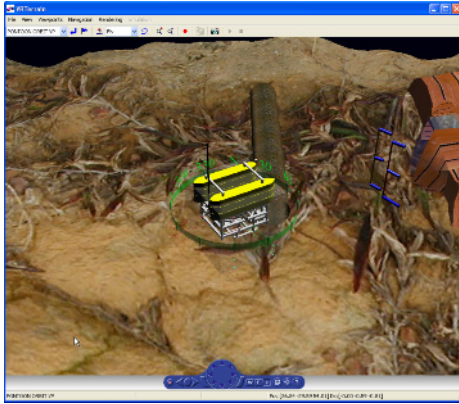

Fig. 7.14 VR display during heave autotuning

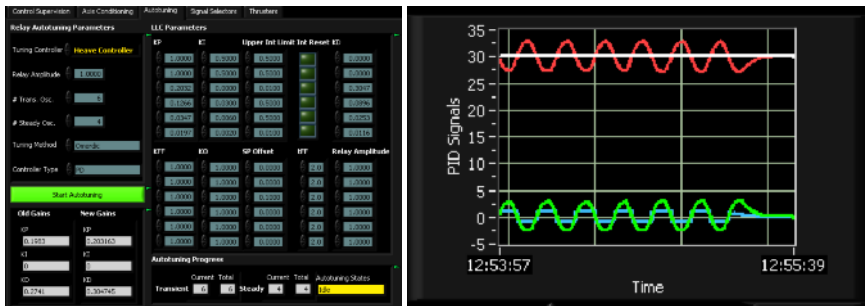

Fig. 7.15 Autotuning parameters and real-time data monitoring

### 7.3.6 High Frequency Sonar Enabling at Seabed Operation

When operating in near-seabed mode for video camera footage acquisition, DVL and altimeter sonar become unreliable due to the minimum blanking range of the instruments (typically 0.5–1.0 m) and this is at the point of most threat from seabed hazards. To give reliable height off bottom readings in this critical near-seabed zone, special optical fibre whisker sensors [14] and high frequency (1 MHz) wide beam angle (30°) sonar which give range readings down to 2 cm [15] have been developed.

### ***7.3.7 Interchangeable Inshore and Deep Water Winch System***

The system has an ROV umbilical winch with a small footprint and weight suitable for deploying the ROV from inshore vessels of opportunity. Depending on survey boat size, the ROV is either towed to site (small boat) or craned in and out of the water (medium sized boat). By design, the inshore winch system can be swapped out with a second deep water ROV winch system and the overall system operation remains unaffected enabling ROV operational flexibility from inshore to the edge of the continental shelf. The winch is of an all-electric design. The umbilical on this winch is specified to include 2x20 A, 250 VDC circuits, 3 x 5 A 220 VAC circuits, and four single-mode optical fibre cores.

Optical fibre passes are unusual on inshore ROV winch systems. However, they are included to enable seamless switching from inshore (winch) operation to deep water (winch) operation. The deep-water ROV umbilical winch allows for deploying the ROV from vessels of opportunity. The winch can accommodate 1,500 m umbilical length.

## **7.4 System Testing**

The integrated payload systems and navigation positioning instruments have all been integrated and operated on previous surveys on ROVs and surface-towed pontoons. The vehicle control systems, low level controllers, fault tolerant control, and instrument controllers have been developed, integrated and tested in the Virtual Underwater Lab, an integral part of the MPPT Ring [16] which facilitates hardware in the loop testing. The systems have further been tested in a test tank at the University of Limerick.

Payload sensor systems are integrated and prepared for marine offshore operations in the test tank which facilitates a full power-on wet test of the integrated systems prior to mobilisation. Testing of the complete integrated system (vehicle and payload sensors) is planned for Foynes Dock on the Shannon estuary prior to trials onboard the vessel *Celtic Explorer*.

## **7.5 Conclusions**

This chapter presents the concurrent development of the University of Limerick thrusted pontoon/ROV, a novel, multi-mode of operation marine robotics vehicle, and MPPT Ring, a novel development platform featuring easy integration of survey equipment, efficient planning and mission simulation, training of ROV pilots, fault-tolerant control of ROVs, enhanced operator environment and survey tools during mission execution and offline analysis of acquired data. The main

features, architecture and implementation issues are described in a compact way. The MMRRRC is building a flexible multi-mode of operation survey vehicle (thrusting pontoon/ROV) for surface and underwater operations based on the technologies and the architecture proposed in this chapter.

The vehicle has been designed with operational flexibility as a key criterion for high-resolution near-seabed survey from shallow and inshore coastal waters out to the continental shelf edge. The vehicle can be operated in surface deployment mode either as a towed platform or as a thrusting pontoon. With the release of buoyancy modules, the vehicle becomes neutrally buoyant and is operated as a survey class ROV depth rated to 1,000 m.

Special features of the system include deployment system interoperability with interchangeable winch and umbilical systems for both small inshore boats and larger research vessel deployment in offshore operations. The vehicle has many other advanced features to allow near-intervention/near-seabed operation, including fault tolerant thruster control, novel high frequency sonar enabling at-seabed operation and onboard electronics and computer control enabling real-time reaction to environmental change/disturbance. The vehicle is also deployed, operated and pilot controlled with a topside augmented reality system, giving a pilot interface benefiting from virtual environment enhancement of the real world operating scenario. The first sea test trials are expected to be performed in Winter 2008.

## References

1. Grehan A, Wilson M, Guinan J, Riordan J, Molnar L, Omerdic E, Ullgren J, Le Guilloux E, Toal D, Brown C (2005) ROV Investigations of Cold-Water Coral Habitats along the Porcupine Bank Margin, West Coast of Ireland. 3rd Int. Symp. on Deep-Sea Corals, Miami
2. Grehan A, Toal D, Brown C (2006) ROV Investigations of Cold Water Coral Habitats in the Porcupine/Rockall off the west coast of Ireland. *The Irish Scientist Yearbook*, **14**:96
3. Molnar L, Omerdic E, Toal D (2005) Design of advanced AUV for deployment close to seabed and other hazards. *Ocean 2005 Europe*, Brest
4. Toal D, Omerdic E, Nolan S, Al-Shamma'a A (2006) Intervention AUVs for permanent seabed observatories, addressing some of the key technical challenges, 4th IEEE Int. Workshop on Scientific Use of Submarine Cables & Related Technologies, Dublin
5. Omerdic E, Riordan J, Toal D (2008) MPPT Ring – Multi-Purpose Platform Technologies for Subsea Operations. *IFAC Workshop on Navigation, Guidance and Control of Underwater Vehicles*, Killaloe
6. Ridao P, Batlle E, Ribas D, Carreras M (2004) NEPTUNE: A HIL Simulator for Multiple UUVs, *Oceans'04*
7. Omerdic E, Riordan J, Molnar L, Toal D (2006) Virtual Underwater Lab: Efficient Tool for System Integration & UUV Control Development, 7th IFAC Conf Manoeuvring & Control of Marine Craft, Lisbon
8. Riordan J, Toal D (2008) Performance Optimised Reverberation Modelling for Real-Time Synthesis of Sidescan Sonar Imagery, *IEEE J. of Oceanic Engineering*, In print

9. Wilson MFJ, O'Connell B, Brown C, Guinan JC, Grehan AJ (2007) Multiscale Terrain Analysis of Multibeam Bathymetry Data for Habitat Mapping on the Continental Slope. *Marine Geodesy*, **30**:3–35
10. Riordan J (2006) Performance Optimised Reverberation Modelling for Real-Time Synthesis of Sidescan Sonar Imagery. Ph.D. University of Limerick
11. Thurman E, Riordan J, Toal D (2007) Automated Optimisation of Simultaneous Multibeam and Sidescan Sonar Seabed Mapping, Ocean 2007 Europe, Aberdeen
12. Omerdic E, Roberts GN (2006) Control Allocation for Over-Actuated Thruster-Propelled Underwater Vehicles, in *Advances in Unmanned Marine Vehicles*, IEEE publication
13. Miskovic N, Vukic Z, Barisic M, Tovornik B (2006) Autotuning Autopilots for Micro ROVs. *Proceedings of 14th Mediterranean Conf. Control and Automation (MED06)*, Ancona
14. Toal D, Flanagan C, Lyons WB, Nolan S, Lewis E (2005) Proximal object and hazard detection for autonomous underwater vehicle with optical fibre sensors. *Robotics and Autonomous Systems*, **53**(3-4):214–229
15. Nolan S, Toal D (2008) A low directivity ultrasonic sensor for collision avoidance and station keeping on inspection-class AUVs. *IMarEST Journal of Marine Engineering, Science and Technology*, Part A, In print
16. Omerdic E, Riordan J, Toal D (2007) Easing Offshore Ops Through the Use of Augmented Reality Support Tools, *Unmanned Underwater Vehicle Showcase*, Southampton

# Chapter 8

## Wireless Communication Technology for Modular Mechatronic Controllers

Glen Bright<sup>1</sup>, Nkgatho S. Tlale<sup>2</sup> and Christopher M. Kumile<sup>3</sup>

### 8.1 Introduction

Modular mechatronic systems are comprised of mechatronic subsystems that are functionally complete and can be independently operated. These subsystems can be readily fitted and connected to, or in combination with, additional subsystems [1]. Advantages of the modular mechatronic design of systems include flexibility to changing environmental needs, low cost due to standardisation of the subsystems, interconnect ability and interchangeability of subsystems with each other, and improved system reliability due to modular architecture [2].

Communication technology allows for the systematic integration of mechatronic subsystems in order to achieve a complex integrated mechatronic system which would be difficult to achieve without the use of information technology (IT). Communication technology allows for the remote, real-time control of mechatronic systems, e.g., the use of communication to send control signals from haptic device and feedback signals from a robotic manipulator in robotics-aided surgery where the surgeon and patient are in different locations (e.g., countries).

In Figure 8.1, three different levels of communications are illustrated. The choice of communication technology to be used is dependant on the complexity, size and response time requirements of the tasks to be controlled. It is important to match the time delay of the communication system with the time constant of the system/process being controlled. If the time delays of the communication system are not an issue, high level protocols can be used to control low level system components/subsystems. Generally, high level system tasks can be adequately controlled by use of a high level communication protocol (e.g., ethernet), while

---

<sup>1</sup> University of KwaZulu-Natal, South Africa

<sup>2</sup> Council for Scientific and Industrial Research, South Africa

<sup>3</sup> Tshwane University of Technology, South Africa



low level system tasks are adequately controlled with a low level communication protocol (e.g., CanBus).

Communication technology in mechatronic systems also allows the achievement of distributed control. However, this results in communication lags due to the distributed architecture. This further introduces problems that are concerned with timing, such as the lag effect associated with zero-order hold (ZOH) and problems with respect to motion control. Problems of time variation can be addressed in control design, e.g., by using robust control so that deviations from nominal timing can be tolerated [3]. This chapter focuses more on the modelling of such systems before the controller is implemented, i.e., the determination of the dynamics of mechatronic systems in order to determine the correct controller reaction time.

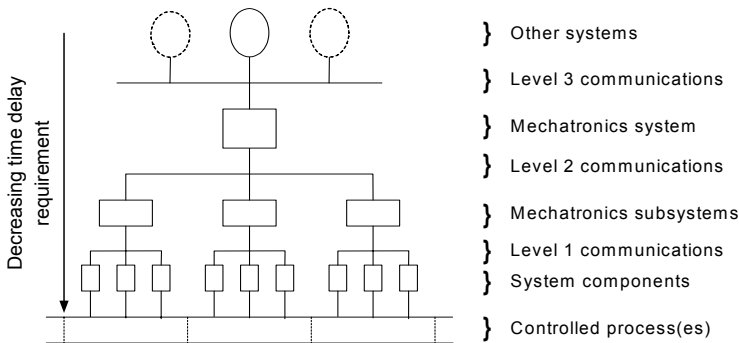
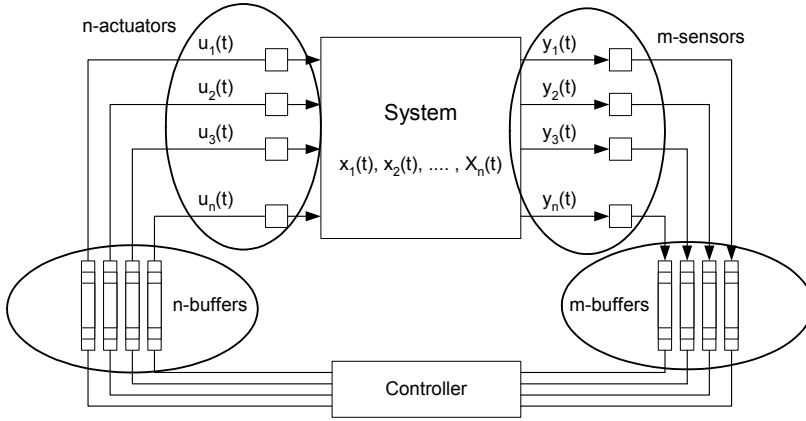

**Fig. 8.1** Classification of different mechatronic and communications levels

## 8.2 Modular Mechatronic Controllers

Mechatronic controllers are generally embedded controllers that use some form of model or heuristic rules for the underlying system in order to achieve optimal control of the system by monitoring sensor inputs and adjusting actuator outputs. The physical and software components of a mechatronic controller are then; signal conditioning hardware unit, signal processing software unit, central processing unit (CPU), power electronics unit, communication circuits and communication software unit.

Figure 8.2 shows a multiple-input multiple-output (MIMO) mechatronic system with sensors, controller and actuators controlling a system/process. The system can be described by its state variables  $\mathbf{x}(t)$ . The actuators outputs,  $\mathbf{u}(t)$ , are the inputs of the system, while the outputs of the system,  $\mathbf{y}(t)$ , are the inputs to sensors. A SISO system is comprised of only one sensor and one actuator.



**Fig. 8.2** Mechatronic controller on a process level

The use of communication technology requires communication nodes at sensors, controllers and actuator nodes. The communication network is used to transmit the information between sensors, controllers and actuators. The transmission of information over a communication network takes some time, which leads to communication lags. In many cases, the communication lags are varying in a random fashion.

Communication lags depend on the configuration of the network and the scheduling policy used. Factors like the network load, priorities of the other ongoing communications, and electrical disturbances affect the communication lags [4]. The communication lag at time interval  $k$  can be subdivided into three parts:

- the communication lags between the sensor and the controller,  $\tau_k^{sc}$  ;
- the computational lag in the controller,  $\tau_k^c$  ; and
- the communication lag between the controller and the actuator,  $\tau_k^{ca}$  .

The control delay,  $\tau_k$ , can then be defined as the time from when a sensor receives a signal to when it is used in the actuator as the control signal. Thus,

$$\tau_k = \tau_k^{sc} + \tau_k^c + \tau_k^{ca} . \tag{8.1}$$

The Nyquist theorem states that the controller reaction time must be at least half of the smallest time constant of the system to ensure proper system control [5].

Depending on how the sensors, actuators, and controller nodes are synchronised, several setups can be considered. Event-triggered controllers send information as soon as it is available to the nodes (i.e., sensors and controllers). The information is itself generated by some programmed activity (e.g., the signal

being monitored achieving some specified level). Time-triggered systems transmit the information based on some time model using the clock of the system as reference. The node is able to start its activity at a pre-defined time (e.g., node's activities can be periodic). By implementing communication technology, a distributed MIMO system can be achieved. Instead of centralising intelligence in one controller, intelligence can be distributed on and between the different sensors and actuators in the system.

Control and processing of data can only be done when data is available at the node. Vacant sampling occurs when data does not arrive at the communication node on time. To limit the level of vacant sampling, the buffers must be longer than the worst case communication lag [6]. Buffering can be used between the sensors, controllers, and actuators. This minimises the variation of the communication lags between the communicating nodes and can be used to produce constant communication lags. The disadvantage of using buffers is that the control delay can become longer than necessary. This can lead to decreased controller performance.

### 8.3 Communications Technology

Communications technology is used in mechatronic systems to achieve distributed real-time control systems. The choice of the communication technology implemented in a mechatronic system is dependent on the following:

- the spatial distances between the units of the system;
- the amount of information to be transferred via the communication technology (or bandwidth); and
- the response time that is required from the communication technology.

For long distances (> 10 m, level 3 communication), communication protocols such as the Transmission Control Protocol/Internet Protocol (TCP/IP), ProfiBus, DeviceNet, FieldBus, Modbus, etc. are used [7]. These technologies are normally used to connect one mechatronic system to a network of other mechatronic systems. For medium distances (< 10 m, > 1 m, level 2 communications), communication protocols such as the Controller Area Network (CAN), RS232, RS485, RS422, GBIP, etc. are used. These protocols are also used in instrumentation devices.

For short distances (< 1 m, level 1 communication), communication protocols such as CAN, Inter-Integrated Circuit (I<sup>2</sup>C), Serial Peripheral Interface (SPI), embedded TCP/IP, etc. are used. These protocols are normally used to connect one microprocessor to others.

## 8.4 Model-based Mechatronic Controllers

The difference between a model-based controller and a knowledge-based controller is that the latter uses rules or heuristics, while the former uses some model of the system in order to achieve control of the system.

For a SISO mechatronic system, let  $\mathbf{x}(t)$  ( $= [x(t_1), x(t_2), \dots, x(t_n)]$ ) be a state variable that can be used to fully describe a continuous-time varying system defined by  $f(t)$ . This infinite dimension system can then be described by Equation 8.2:

$$f(t) = g(\mathbf{x}(t)). \quad (8.2)$$

Let the controlled process be defined by:

$$\mathbf{x}(t) = \mathbf{A} \mathbf{x}(t) + \mathbf{B} \mathbf{u}(t) + \mathbf{v}(t) \quad (8.3)$$

where  $\mathbf{A}$  is the state constant

$\mathbf{B}$  is the input constant

$\mathbf{u}(t)$  describes the input

and

$\mathbf{v}(t)$  is white noise with zero mean and has covariance  $R_v$ .

The control loop of this mechatronic system can be formulated by sampling. Assuming that the sampling period,  $h$ , is constant and greater than the delay from the sensor to the actuator (i.e.,  $h > \tau_k^{sc} + \tau_k^{ca}$ ). Integrating Equation 8.3 over a sampling interval then results in Equation 8.4.

$$x_{k+1} = \Phi x_k + \Gamma_0(\tau_k^{sc}, \tau_k^{ca}) u_k + \Gamma_1(\tau_k^{sc}, \tau_k^{ca}) u_{k-1} + v_k \quad (8.4)$$

where

$$x_k = x(kh) \quad (8.5)$$

$$\Phi = e^{A h}$$

$$\Gamma_0(\tau_k^{sc}, \tau_k^{ca}) = \mathbf{B} \int_0^{h - \tau_k^{sc} - \tau_k^{ca}} e^{A s} ds \quad (8.6)$$

$$\Gamma_1(\tau_k^{sc}, \tau_k^{ca}) = \mathbf{B} \int_{h - \tau_k^{sc} - \tau_k^{ca}}^h e^{A s} ds \quad (8.7)$$

and a variance of

$$-v_k = R_1 = E[v_k^2] = R_v \int_0^h (e^{-\Lambda(h-s)})^2 ds. \quad (8.8)$$

This result is the same as those found in [7] and [8]. These are standard results for the sampling of systems with time-delays, where the infinite-dimensional continuous-time system is reformulated to the time-varying, finite-dimensional, discrete-time system. The output equation is then:

$$y_k = Cx_k + w_k \quad (8.9)$$

where  $C$  is the output constant and  $w_k$  is a random process of white noise which is uncorrelated to  $v_k$ . The mean of  $w_k$  is zero and its co-variance is  $R_2$ .

A linear controller for this system can be written as

$$x_{k+1}^c = \Phi^c(\tau_k)x_k^c + \Gamma^c(\tau_k)y_k \quad (8.10)$$

$$u_k = C^c(\tau_k)x_k^c + D^c(\tau_k)y_k \quad (8.11)$$

where  $\tau_k$  in  $\Phi^c$ ,  $\Gamma^c$ ,  $C^c$  and  $D^c$  means that the controller is aware of the network delays completely or partly, i.e.,  $\{\tau_0, \dots, \tau_k, h_0, \dots, h_{k-1}\}$  are known to the controller before  $u_k$  is calculated. This can be achieved by time-stamping of network messages and time synchronisation of the communicating nodes.

Substituting  $u_k$  in  $x_{k+1}$  and  $y_k$  in  $u_k$  and re-arranging, the closed-loop system can be written as

$$z_{k+1} = \Phi(\tau_k)z_k + \Gamma(\tau_k)e_k \quad (8.12)$$

where

$$z_k = \begin{bmatrix} x_k \\ x_k^c \\ u_{k-1} \end{bmatrix} \quad (8.13)$$

$$\Phi(\tau_k) = \begin{bmatrix} \Phi + \Gamma_0(\tau_k)D^c(\tau_k)C & \Gamma_0(\tau_k)C^c(\tau_k) & \Gamma_1(\tau_k) \\ \Gamma^c(\tau_k)C & \Phi^c(\tau_k) & 0 \\ D^c(\tau_k)C & C^c(\tau_k) & 0 \end{bmatrix} \quad (8.14)$$

$$\mathbf{e}_k = \begin{bmatrix} v_k \\ w_k \end{bmatrix} \quad (8.15)$$

and the variance  $R$  of  $e_k$  is

$$R = E(e_k, e_k^T) = \begin{bmatrix} R_1 & 0 \\ 0 & R_2 \end{bmatrix} \quad (8.16)$$

The form of  $\Phi(\tau_k)$  and  $\Gamma(\tau_k)$  is determined by the process, the communication network, and the controller structure. Here,  $\tau_k$  is a random process uncorrelated with  $\{e_k\}$  and can be a vector consisting of the delay from sensor to controller,  $\tau_k^{sc}$ , as well as the delay from controller to actuator,  $\tau_k^{ca}$ . It is assumed that  $\tau_k$  has a known distribution pattern and that  $\tau_k$  is independent from different  $k$ . If the sampling period,  $h$ , is not constant, this results in sampling interval jitter. Equation 8.4 then becomes:

$$x_{k+1} = \Phi x_k + \Gamma_0(h_k, \tau_k^{sc}, \tau_k^{ca}) u_k + \Gamma_1(h_k, \tau_k^{sc}, \tau_k^{ca}) u_{k-1} + \Gamma_v(h_k) v_k \quad (8.17)$$

For a MIMO system with  $m$  sensors and  $n$  actuators, the system equations are:

$$\mathbf{x}(t) = \mathbf{A}\mathbf{x}(t) + \mathbf{B}\mathbf{u}(t) + \mathbf{v}(t) \quad (8.18)$$

where  $\mathbf{A}$  and  $\mathbf{B}$  are now matrices.

The longest sensor to controller delay is defined as:

$$\bar{\tau}_k^{sc} = \max(\tau_k^{sc1}, \tau_k^{sc2}, \dots, \tau_k^{scm}) \quad (8.19)$$

and assuming that the old time delays are known to the controller and that that sampling period is greater than the delay from the sensor to actuator; i.e.,

$$\max(\tau_k^{sc1}, \tau_k^{sc2}, \dots, \tau_k^{scm}) + \max(\tau_k^{ca1}, \tau_k^{ca2}, \dots, \tau_k^{can}) < h \quad (8.20)$$

Equation 8.16 can be sampled into:

$$x_{k+1} = \Phi x_k + \Gamma_0(\bar{\tau}_k^{sc}, \tau_k^{ca1}, \dots, \tau_k^{can}) u_k + \Gamma_1(\bar{\tau}_k^{sc}, \tau_k^{ca1}, \dots, \tau_k^{can}) u_{k-1} + v_k \quad (8.21)$$

where

$$x_k = x(kh) \quad (8.22)$$

$$\Phi = e^{Ah} \quad (8.23)$$

$$\Gamma_0(\bar{\tau}_k^{sc}, \tau_k^{ca1}, \dots, \tau_k^{can}) = \left[ \Gamma_0^1(\bar{\tau}_k^{sc}, \tau_k^{ca1}) \quad \dots \quad \Gamma_0^n(\bar{\tau}_k^{sc}, \tau_k^{can}) \right] \quad (8.24)$$

$$\Gamma_1(\bar{\tau}_k^{sc}, \tau_k^{ca1}, \dots, \tau_k^{can}) = \left[ \Gamma_1^1(\bar{\tau}_k^{sc}, \tau_k^{ca1}) \quad \dots \quad \Gamma_1^n(\bar{\tau}_k^{sc}, \tau_k^{can}) \right] \quad (8.25)$$

$$\Gamma_0^i(\bar{\tau}_k^{sc}, \tau_k^{ca1}) = B \int_0^{h - \bar{\tau}_k^{sc} - \tau_k^{ca1}} e^{As} ds \quad (8.26)$$

$$\Gamma_1^i(\bar{\tau}_k^{sc}, \tau_k^{ca1}) = B \int_{h - \bar{\tau}_k^{sc} - \tau_k^{ca1}}^h e^{As} ds \quad (8.27)$$

and the variance of state noise

$$v_k = R_1 = E[v_k, v_k^T] = \int_0^h e^{A(h-s)} R_v \left( e^{A(h-s)} \right)^T ds \cdot \quad (8.28)$$

The output equation is then:

$$y_k = Cx_k + w_k \cdot \quad (8.29)$$

## 8.5 Wireless Mechatronic Controller for the Camera Platform

In this project, the aim was to replace the tether connection between a camera platform and the operator platform, see Figure 8.3, used in the film industry. The operator platform consisted of two hand-wheels (with their respective encoders) that controlled the roll and the yaw orientations. The joystick was then used to control the pitch orientation. The hand-wheels had adjustable viscous dampers to maintain the feel of a typical hand-wheel for conventional camera platforms. The hand-wheels, joystick and associated electronics were mounted on a separate box (operator side) from the camera platform (camera platform side). The hand-wheels and the joystick were used to determine the direction of turn, positional control, speed and acceleration [9].

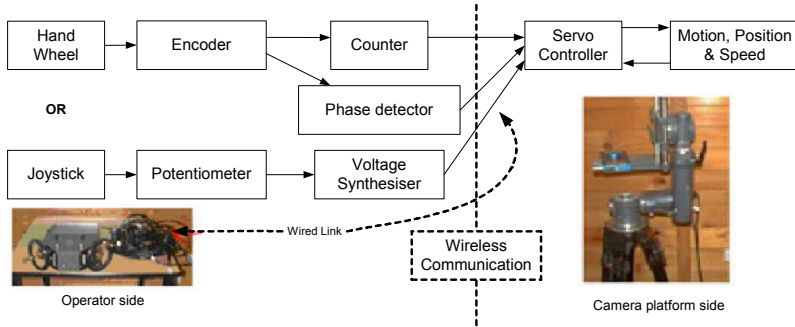

Fig. 8.3 A camera platform with tether connection

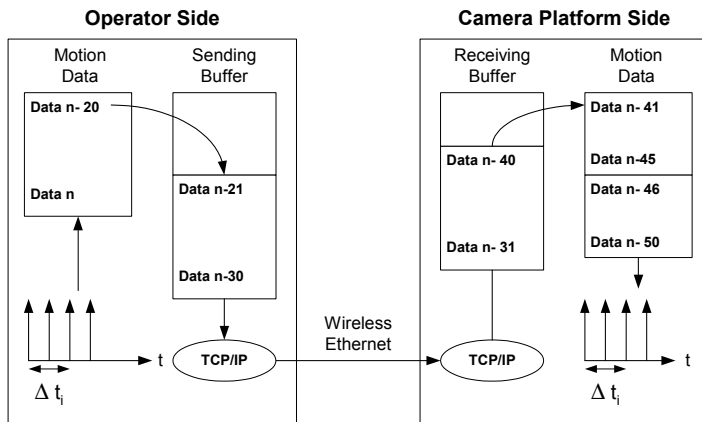

Fig. 8.4 Flow of data through the wireless mechatronic controller for camera platform

After acquiring the signal from the sensors, the servo-controller implemented a PID routine to control the position, velocity and acceleration of the camera platform motors within the required response time. The developed wireless communication system was required to send the position, speed, acceleration and time-stamp information to the camera platform’s servomotor controller. Figure 8.4 shows the data flow through the mechatronic control system.

### 8.5.1 Requirements for the Wireless Mechatronic Controller

Wireless communication was required to transmit the control commands only without the vision information from the camera. The average sight reaction time of trained camera operators of  $t_0 = 0.2466$  s was used as a benchmark for the minimum response time of the integrated system [10]. The developed hard-wired system was determined to have a satisfactory lag/response time of  $t_{sh} = 0.062$  s



(i.e.,  $t_o \gg t_{sh}$ ). For the developed wireless system,  $t_o$  must be less than 0.20 s (using a safety factor of 20%) in order to achieve satisfactory control of the camera platform.

The total number of bytes per second required to be handled by the wireless communication system in order to effectively control the camera platform was determined to be 20.00156 Kbytes per 1/60th of a second (i.e., sampling rate of 60 Hz). This included 25% more bytes for address, time-stamping and error-checking the data.

Wireless ethernet implemented at a carrier frequency of 2.4 GHz (or 300 000 Kbytes/sec) and IEEE 802.11 b standard was used on two single board computers (the sender and the receiver) was implemented as a solution. Analysis of network utilisation results in [11]:

$$U = \sum_i \frac{C_i}{T_i} = 4.00098 \times 10^{-3} \quad (8.29)$$

where  $i$  is the number of periodic transmissions on the bus,  
 $C_i$  is the transfer time for this message  
 and  
 $T_i$  is the period for sending of message (i).

The utilisation is a measure of how much load there is on the bus. A utilisation of  $4.00098 \times 10^{-3}$  indicates the bus load is very low. If the utilisation is greater than 1, the bus has overload. However, in practice, if  $T_i$  increases, there is a high network utilisation being experienced.

## 8.6 Modelling of the Camera Platform

In order for the camera operator to control the motion of the camera intuitively, a controller that could combine and resolve the various motions of the camera joint motors into separately controllable hand motions along the world coordinates axes was required. Such a control scheme is termed *resolved motion control*. This means that the several joint motors would run simultaneously at different time-varying rates in order to achieve desired coordinated hand motion along any world coordinate axis. This would enable the camera operator to specify the direction and speed of motion along any arbitrary oriented path for the camera to follow.

A typical camera platform used in the film industry can be described as a three degree of freedom (DOF), spatial revolute manipulator. Using the Denavit-Hartenberg technique, the coordinate axes of the three rotational axis of the camera platform were positioned and the kinematics parameters of the manipulator determined [12]. The homogenous transformation matrix that describes the orientation and position of the camera was determined as:

$$\text{base } \mathbf{T}_{\text{hand}}(t) = \begin{bmatrix} n_x(t) & s_x(t) & a_x(t) & p_x(t) \\ n_y(t) & s_y(t) & a_y(t) & p_y(t) \\ n_z(t) & s_z(t) & a_z(t) & p_z(t) \\ 0 & 0 & 0 & 1 \end{bmatrix} = \begin{bmatrix} \mathbf{n}(t) & \mathbf{s}(t) & \mathbf{a}(t) & \mathbf{p}(t) \\ 0 & 0 & 0 & 1 \end{bmatrix} \quad (8.31)$$

$${}^0\mathbf{T}_3 = \begin{bmatrix} C_1C_2C_3 - S_1S_3 & C_1C_2S_3 - S_1C_3 & C_1S_2 & C_1C_2(c+a) - dS_1 \\ S_1C_2C_3 + C_1S_3 & S_1C_2S_3 + C_1S_3 & S_1S_2 & S_1(cC_1 + aS_2) + dC_1 \\ -S_2C_3 & -S_2S_3 & C_1 & -S_2(c+a) \\ 0 & 0 & 0 & 1 \end{bmatrix}. \quad (8.32)$$

Where  $\mathbf{p}$  is the position vector of the camera,  
 $\mathbf{n}$ ,  $\mathbf{s}$ ,  $\mathbf{a}$  are the unit vectors along the principal axes of the coordinate frame describing the orientation of the camera, i.e., orientation of the hand coordinate system.

The non-linear equation that describes the camera platform is then:

$$x(t) = f(q(t)) = f(\theta_1(t), \theta_2(t), \theta_3(t)) \quad (8.33)$$

where  $\mathbf{x}(t)$  are the world coordinates ( $x, y, z, \alpha, \beta, \gamma$ ) and  
 $\mathbf{q}(t)$  are the generalised coordinates ( $\theta_1, \theta_2, \theta_3$ ).

Taking the first derivative of Equation 8.32 then gives:

$$\frac{d\mathbf{x}(t)}{dt} = \dot{\mathbf{x}}(t) = \begin{bmatrix} \mathbf{v}(t) \\ \boldsymbol{\Omega}(t) \end{bmatrix} = \mathbf{N}(\mathbf{q}) \dot{\mathbf{q}}(t) \quad (8.34)$$

where  $\mathbf{N}(\mathbf{q})$  is the Jacobian matrix with respect to  $\mathbf{q}(t)$ , i.e.,  $N_{ij} = \partial f_i / \partial q_j$ .

The acceleration of the camera platform can also be determined to be:

$$\begin{bmatrix} \dot{\mathbf{v}}(t) \\ \dot{\boldsymbol{\Omega}}(t) \end{bmatrix} = \mathbf{N}(\mathbf{q}, \dot{\mathbf{q}}(t)) \dot{\mathbf{q}}(t) + \mathbf{N}(\mathbf{q}) \ddot{\mathbf{q}}(t). \quad (8.35)$$

For redundant manipulators, the inverse  $\mathbf{N}^{-1}(\mathbf{q})$  cannot be determined. It can be found by minimising an error criterion formed by adjoining the previous equation with a Lagrange multiplier to a cost criterion,  $C$ :

$$C = \frac{1}{2} \dot{\mathbf{q}}^T \mathbf{A} \dot{\mathbf{q}} + \boldsymbol{\lambda}^T [x - \mathbf{N}(\mathbf{q}) \dot{\mathbf{q}}] \quad (8.36)$$

where  $\boldsymbol{\lambda}$  is a Lagrange multiplier vector and  
 $\mathbf{A}$  is an  $m \times m$  symmetric, positive definite matrix.

After minimising with respect to  $\lambda$ , the angular velocities of the joints can be determined to be:

$$\mathbf{q}(t) = \mathbf{A}^{-1} \mathbf{N}^T(\mathbf{q}) [\mathbf{N}(\mathbf{q}) \mathbf{A}^{-1} \mathbf{N}^T(\mathbf{q})]^{-1} \mathbf{x}(t). \quad (8.37)$$

Elements of the Jacobian matrix were then determined to be:

$$\mathbf{N}_1 = \begin{bmatrix} (C_1 + C_2)(c+a) - dS_1 \\ S_1(cC_1 + aS_2) + dC_1 \\ -S_1(c+a) \\ 0 \\ 0 \\ 1 \end{bmatrix}, \mathbf{N}_2 = \begin{bmatrix} (C_1 + C_2)(c+a) - dS_1 \\ S_1(cC_1 + aS_2) + dC_1 \\ -S_1(c+a) \\ S_1 \\ C_1 \\ 0 \end{bmatrix} \quad \text{and} \quad (8.38)$$

$$\mathbf{N}_3 = \begin{bmatrix} cS_1S_2^2 + acS_1S_2C_1 \\ cC_1S_2^2 + acC_1C_2S_2 \\ cS_1S_2C_1^2 + cC_1C_2S_1S_2 \\ C_1C_2 \\ S_1S_2 \\ -S_2 \end{bmatrix}$$

## 8.7 Results

A test involving round-trip times of different data packets over the wireless communication network was carried out. Round-trip time is the time a data packet takes to be received by the transmitter from the time of transmission, i.e., time from transmitter to receiver and back to transmitter [13]. This test emulates when the time-stamps are used during error checking of the system. This test indicated that the performance of the wireless communication system was inferior to the one shown in Figure 8.5 (a). Figure 8.5 (b) then shows the results of this test.

The results in Figure 8.5 (b) were obtained under ideal conditions. There was a line of sight between the transmitter and the receiver. As soon as the line of sight was lost, the system became unreliable. A response time of 0.72 s for a data packet of 120 Kbytes indicated that the system would not have had a satisfactory performance with data throughput of 160.0125 Kbytes/second as determined in the previous section. In order to improve the system reliability and performance, techniques for reducing the minimum data transfer rate acceptable to optimally control the camera platform had to be used. A mechatronic design of the integrated camera platform was implemented in order to achieve this.

### 8.7.1 Performance of the System

The total response time of the PID servo-controller and DC servomotor was determined by exciting the system with a ramp input of about 3000 Kbytes/second. This was twice the anticipated input signal as determined previously. Figure 8.6 shows the response times of the system and error. The error increased with increasing input signal. The system exhibited a degree of second order response to a ramp input. It can be seen that the response times were in milliseconds. The maximum response in lag occurred at 140 Kbytes/second and was equal to 25 ms. This was satisfactory for the considered application.

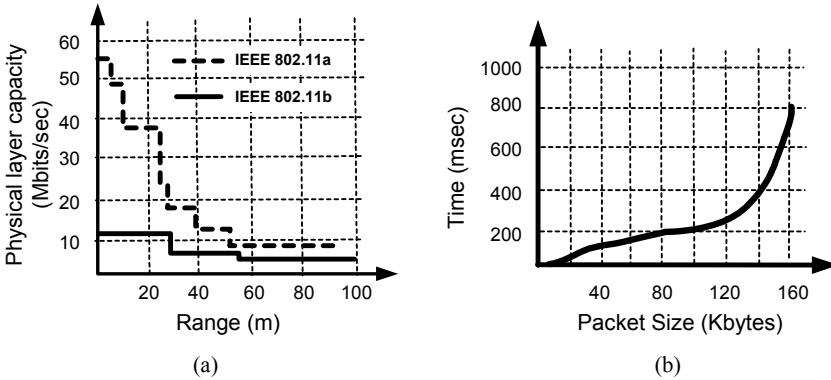

**Fig. 8.5** (a) Physical Layer Capacity of the Belkin Wireless Ethernet [14], and (b) Round-times for data packets of different sizes implementing TCP/IP with line of sight

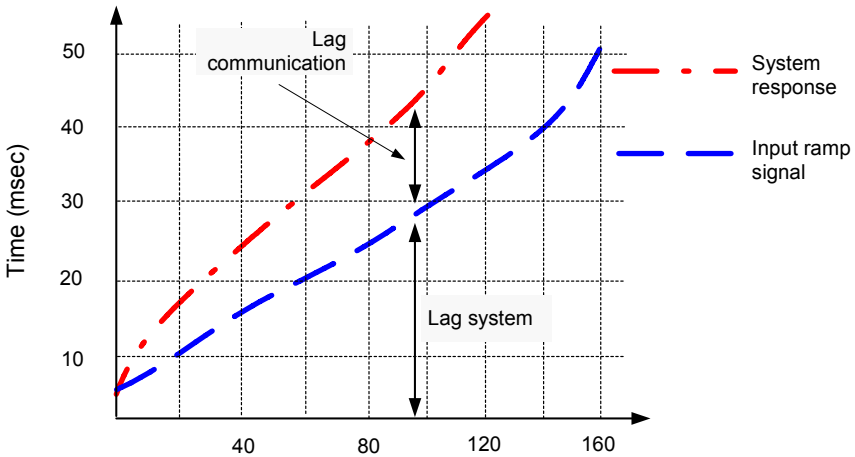

**Fig. 8.6** Performance of the wireless mechatronic controller

## 8.8 Conclusions

The concept of a wireless modular mechatronic system comprising of mechatronic subsystems has been presented. Communication technology has provided a wireless solution to achieve an integrated mechatronic system. Wireless technology has allowed for a remote, real-time control of a mechatronic system. A camera platform was successfully controlled using wireless communication technology. Communication nodes were used to facilitate the transfer of information from the modules/subsystems. The dynamics of the mechatronic control system was determined in order to determine the correct controller reaction time.

The wireless communication technology in the mechatronic controller provided distributed control. Delays of distributed control systems were minimised through the introduction of communication technology. Problems associated with timing, such as lag effect of ZOH and those with respect to motion control were addressed. Problems of time variations were also addressed in the control design by using robust control so that deviations from nominal timing could be tolerated.

## References

1. Virk GS (2003) CLAWAR modularity for robotic systems, *Int. Journal of Robotics Research*, **22** (3-4); 265–277
2. Bi Z (2002) On adaptive robot systems for manufacturing applications, Ph.D. Thesis, Dept. of Mechanical Engineering, University of Saskatchewan, Saskatoon
3. Chen D-J (2001) Architecture for systematic development of mechatronic software systems', Licentiate Thesis, ISSN 1400-1179, Mechatronic Lab, Department of Machine Design, Royal Institute of Technology, KTH, Stockholm
4. Ray A (1987) Performance evaluation of medium access control protocols for distributed digital avionics, *Trans. ASME Journal of Dynamic Systems, Measurement and Control*, **109**; 370–377
5. Nise NS (2008) *Control Systems Engineering*, 5th Edn, John Wiley and Sons
6. Luck R, Ray A (1990) An observer-based compensator for distributed delays, *Automatica*, **26** (5); 903–908
7. Åström KJ, Wittenmark B (1997) *Computer-controlled systems*, 3rd Edn, Prentice Hall
8. Neilson J (1998) Real-time control systems with delays, Ph.D. Thesis, Department of Automatic Control, Lund Institute of Technology
9. Tlale NS, Potgieter J, Bright G (2003) Wireless mechatronic controller for tele-operated camera platforms, *Mechatronic and Machine Vision 2003: Future Trends*, Ed. Billingsley J, Research Studies Press Ltd
10. Chudler (2008) Test your reaction time, [faculty.washington.edu/chudler/java/reacttime.html](http://faculty.washington.edu/chudler/java/reacttime.html)
11. Tindell, K, Hansson H (1995) Real time systems and fixed priority scheduling, Technical Report, Department of Computer Systems, Uppsala University
12. Hartenberg RS, Denavit J (1964) *Kinematic synthesis of linkages*, McGraw-Hill
13. Comer DE (2000) *Internetworking with TCP/IP: principles, protocols, and architectures*, Vol 1, 4th Edn, Prentice-Hall
14. Dorman A (2002), Emerging technology: wireless LAN standards, two new wireless LAN standards are cleared for takeoff. Should you climb aboard?, *Network Magazine*.

# Chapter 9

## The Utility Function Method for Behaviour Selection in Autonomous Robots

Mattias Wahde<sup>1</sup>

### 9.1 Introduction

In behaviour-based robotics (BBR), the *artificial brain* (or control system<sup>2</sup>) of a robot is built from a repertoire of basic behaviours which are activated or deactivated through a process of *behaviour selection* that uses the state of the robot (and, possibly, its environment) as input [1–3].

Many behaviour-based systems are strongly reactive, i.e., there is a more or less direct connection between perception and action unlike the systems defined in classical artificial intelligence (AI) which are more deliberative, but typically operate quite slowly. In practice, it is common that the definition of a robotic brain involves a combination of the bottom-up approach defined in BBR and the top-down approach defined in classical AI [1].

The field of BBR is in a stage of rapid development and steps are being taken to move away from the purely reactive realm [4, 5] while still maintaining the many positive aspects of the approach, e.g., the ability of a robot to respond quickly to changes in sensory input. However, in order for a behaviour-based robot to be capable of carrying out a complex task, it must be able to activate the appropriate behaviour(s) at any given time, i.e., to carry out decision-making in the form of behaviour selection.

At first glance, the problem of behaviour selection may not appear to be very difficult. In reality, however, the problem is quite hard, not least because it is notoriously difficult to predict, in advance, which situations the robot might face, and in what order. Behaviour selection systems designed by hand are sometimes very brittle and may break down completely if an unexpected event occurs, as is

---

<sup>1</sup> Chalmers University of Technology, Sweden

<sup>2</sup> In this chapter, when referring to the system (however simple) that provides the robot with intelligent behaviour, the term *artificial (robotic) brain* is used rather than the term *control system* since the latter term normally is applied when describing the more limited systems such as PID controllers and similar constructs employed in classical control theory.

invariably the case in the unstructured environments in which autonomous robots are normally intended to operate. Furthermore, the robot must commonly make its decisions based on noisy and incomplete information, and the actual outcome of a decision may often differ from the intended one. Incidentally, the problem of representing information in an appropriate way (to guide behaviour selection) is, in itself, a very challenging problem.

This chapter concerns the utility function (UF) method for behaviour selection [3, 6]. Section 9.2 gives a brief description of related work in the field of behaviour selection. The concept of utility, which forms the foundation for the utility function method is introduced in Section 9.3 and is then illustrated by means of a biological example. The UF method is described in Section 9.4 and the chapter concludes in Section 9.5 with a brief discussion of current work.

## 9.2 Behaviour Selection

In the literature, the term *behaviour selection* is sometimes referred to as *action selection* [7] or *behavioural organisation* [8]. Here, the term *behaviour selection* will be used throughout, and it will be assumed that the purpose of the behaviour selection system is to choose a behaviour for activation from a predefined set of *fixed behaviours*. Thus, the topics of *behaviour acquisition* and *behaviour modification* (i.e., learning) will not be covered<sup>3</sup>.

It should be noted that there is some confusion in the literature regarding the definition of behaviours and actions. Here, an *action* is considered to be an elementary operation and a *behaviour* to be a sequence (possibly recurrent, i.e., containing loops) of actions. Examples of (motor) actions include *move forward*, which involves setting the (desired) wheel speeds<sup>4</sup> of the robot to a given value  $v$ , and *rotate*, which amounts to setting the wheel speeds to equal magnitudes but opposite directions. Examples of behaviours include *obstacle avoidance* and *localisation*.

A full description of a behaviour requires, of course, the specification of exactly which actions it uses and under what circumstances the different actions are executed. Typically, a behaviour serves a specific purpose such as, for example, avoiding obstacles. Ideally, behaviours should be written in such a way that they can be used in an off-the-shelf manner so that, when building a robot, one may simply

---

<sup>3</sup> Note, however, that for a robot equipped with a repertoire of behaviours and a behaviour selection system, learning can take place in two different ways: Either through modification of the individual behaviours or through tuning of the behaviour selection system; both processes may change the response of the robot to any given situation, and are therefore instances of learning. As mentioned above, the behaviours will be assumed to be fixed and, once the behaviour selection system has been defined (through optimisation, see Section 9.4), it is also assumed to be fixed, i.e., it does not undergo any modifications while the robot is active.

<sup>4</sup> Here, only two-wheeled differentially steered robots will be considered.

add the appropriate behaviours to the repertoire and then generate a behaviour selection system.

Actions, by themselves, are more of a means to an end, even though there are special cases where a behaviour simply consists of a single action; an example is the *stop* behaviour which can be implemented as the single action *move forward*, with the set speed  $v$  equal to zero.

The topic of behaviour selection has been considered by many authors. In fact, in reviewing the literature, one may wonder why such a large number of different behaviour selection methods have been suggested. One possible reason might be the fact that unlike, say, physics or chemistry, in the topic of behaviour selection, there are no fundamental limitations on the methods and procedures that can be proposed. Of course, any motion of a robot will always follow the laws of physics, but the robotic brain need not have any counterpart in biology, chemistry or physics. In short, anything goes. A full review of the many behaviour selection methods suggested in the literature is beyond the scope of this chapter. Instead, a brief (and probably biased) list of examples will be given, which hopefully can then act as a guide to the literature.

Early examples of behaviour selection methods include the subsumption method [9], activation networks [10] and the potential field method [11]. A method based on dynamical systems theory was suggested by Bergener and Steinhager [8]. The use of emotions in robotic decision-making has also been considered for instance by Gadanho and Hallam [12]. The biological foundation of behaviour selection (and, to some extent, its application in robotics) has been considered by McFarland [13, 14] and more recently in Bryson, Prescott and Seth [15]. Surveys of behaviour selection can be found in Pirjanian [2] and Bryson [5].

Two important drawbacks with many (if not most) behaviour selection methods are the lack of generality and the need for parameter tuning. A loss of generality may occur if, for example, the user is required to specify, in detail, the interactions (activation or suppression, say) between different behaviours for a particular problem. Whenever a new problem is considered, the entire procedure may have to be repeated again from the beginning.

Also, as pointed out in, for instance, Wahde [3] and Blumberg [7], even if only parameter tuning is required, it is often very difficult to manually set the parameters of the behaviour selection system in an appropriate way. In fact, the motivations behind the development of the UF method have been to limit the amount of manual parameter tuning and to provide a behaviour selection method with general applicability, i.e., one that is not developed within the framework of one particular problem.

### 9.3 The Concept of Utility

Rational decision-making has been studied thoroughly in ethology (and, more recently, in robotics [3, 14]). The theory of rational decision-making was formalised



within the framework of economics, particularly in the important work of von Neumann and Morgenstern [16]. The choices facing a decision-maker can often be illustrated by means of *lotteries*, at least in cases where the number of consequences (or *outcomes*) is finite. In lotteries involving money (as they typically do!), one finds that the expected payoff alone is *not* sufficient to determine a person's inclination to participate in a given lottery. To illustrate this, consider a repeated lottery in which a fair coin (equal probability for heads and tails) is tossed repeatedly, and where the player receives  $2^k$  Euros if the first head, say, occurs after  $k$  tosses of the coin. The probability  $p_k$  of this event occurring equals  $(1/2)^k$ . Thus, the expected payoff from playing this lottery would be:

$$P = \sum_{k=1}^{\infty} p_k c_k = \sum_{k=1}^{\infty} \left(\frac{1}{2}\right)^k 2^k = \sum_{k=1}^{\infty} 1, \quad (9.1)$$

which is infinite!

Thus, if the expected payoff  $P$  was all that mattered, a player should be willing to pay any finite sum of money, however large, in order to participate in this lottery since the expected payoff would be larger. This is, of course, absurd; few people would be willing to bet their entire savings on a lottery.

The situation just described is called the *St Petersburg Paradox* and was formulated by Bernoulli, who also proposed a way of resolving the paradox, by postulating that, rather than the expected payoff itself, it is the player's perception of the amount of money gained that determines the actions taken. Bernoulli postulated that the subjective value of  $N$  currency units (e.g., dollars) varies essentially as the logarithm of  $N$ . Let  $W$  denote a person's wealth before participating in the lottery and  $r$  the cost of entering the lottery. Using Bernoulli's postulate, the subjective value  $P_s$  of the expected payoff can then be written as the change in wealth for different outcomes multiplied by the probability of the outcome in question. Thus:

$$P_s = \sum_{k=1}^{\infty} \left( \ln(W - r + 2^k) - \ln W \right) 2^{-k}, \quad (9.2)$$

which is finite. A person should, at most, be willing to pay an amount  $r$  that will make  $P_s$  positive in order to participate in the lottery. For example, for  $W = 1,000$ , the maximum value of  $r$  would be around 10.95 currency units.

The subjective value of a certain amount of money is a special case of the concept of *utility*, which can be used for weighing different situations against each other and, thus, to decide which action to take. In fact, it has been proven (rigorously) by von Neumann and Morgenstern [16] that, given certain assumptions that will be listed below, there exists a *utility function* that maps members  $c_i$  of the set of outcomes to a numerical value  $u(c_i)$ , called the (expected) utility of  $c_i$ , which has the following properties:

1.  $u(c_1) > u(c_2)$  if and only if the person prefers<sup>5</sup>  $c_1$  to  $c_2$ ,
2.  $u$  is affine, i.e.,

$$u(pc_1 + (1-p)c_2) = pu(c_1) + (1-p)u(c_2), \quad (9.3)$$

for any *mixed outcome*, with  $p \in [0, 1]$ .

The axioms on which these results depend<sup>6</sup> are:

*Axiom 1: (Ordering)* – Given two outcomes  $c_1$  and  $c_2$ , individuals can decide, and remain consistent, concerning their preferences, i.e., whether they prefer  $c_1$  to  $c_2$  (denoted as  $c_1 > c_2$ ),  $c_2$  to  $c_1$ , or are indifferent (denoted as  $c_1 \sim c_2$ ).

*Axiom 2: (Transitivity)* – If  $c_1 \geq c_2$  and  $c_2 \geq c_3$ , then  $c_1 \geq c_3$ .

*Axiom 3: (The Archimedean axiom)* If  $c_1 > c_2 > c_3$ , there exists a  $p \in ]0, 1[$  such that  $p c_1 + (1-p) c_3 > c_2$ , and a  $q \in [0, 1]$  such that  $c_2 > q c_1 + (1-q) c_3$ .

*Axiom 4: (Independence)* – For all outcomes  $c_1, c_2$ , and  $c_3$ ,  $c_1 \geq c_2$  if and only if  $pc_1 + (1-p)c_3 \geq pc_2 + (1-p)c_3$  for all  $p \in [0,1]$ .

Clearly, there is no unique set of preferences valid for all decision-makers. One person (or robot) may prefer a consequence  $c_1$  to another consequence  $c_2$ , whereas another person's preferences may be exactly the opposite. Thus, utility says nothing about a person's preferences. However, provided that Axioms 1–4 above hold, it *does* say that there exists a function  $u$  which can serve as a *common currency* in decision-making, i.e., when considering a choice between several different options.

### 9.3.1 A Biological Example

The concept of utility can be used for modelling decision-making both in biological and artificial organisms (e.g., robots). To illustrate the concept, we shall first consider a simple biological example, namely, the kinesis of *E. coli* bacteria. Such bacteria are able to move towards areas of higher concentration of some attractant (i.e., food), and then remain in those areas to feed. Essentially, the bacteria exhibit two locomotion behaviours, namely *straight-line movement* (henceforth denoted  $B_1$ ) and *tumbling* (denoted  $B_2$ ). As the name implies,  $B_1$  involves movement in a given direction. By contrast, in  $B_2$ , a bacterium essentially carries out a random motion, changing directions frequently. Since *E. coli* are very small, they are unable to detect spatial gradients in the food concentration. However, the bacteria are able to detect temporal gradients by comparing the food concentrations at two different *times*.

<sup>5</sup> If (and only if) the person is indifferent between  $c_1$  and  $c_2$ , then  $u(c_1) = u(c_2)$ .

<sup>6</sup> Note that von Neumann and Morgenstern used slightly different axioms, which, however, amounted to essentially the same assumptions as those underlying Axioms 1–4 listed here.

A simple mathematical model of kinesis based on the maximisation of utility can now be formulated [17]. Consider a bacterium faced with the choice of activating either  $B_1$  and  $B_2$  with the aim of finding as much food as possible.

Each behaviour can be associated with a utility function  $U_i$ ,  $i = 1, 2$ , and the maximisation of utility thus implies that  $B_1$  should be active if  $U_1 > U_2$ , and  $B_2$  otherwise. Clearly, only the relative utility values matter and therefore, it implies no restriction to set  $U_2 \equiv 0$ . In contrast,  $U_1$  can be modelled phenomenologically as:

$$U_1(t) = X(t) - V(t) \quad (9.4)$$

where  $X(t)$  is the current food concentration and

$$\frac{dV(t)}{dt} + aV(t) = bX(t) \quad (9.5)$$

where  $a$  and  $b$  are the (positive) parameters of the model.

Now, let  $U_1(t = 0) = 0$ . If the bacterium encounters a sudden increase in the food concentration  $X(t)$ , at time  $t > 0$ ,  $U_1(t)$  becomes positive, thus keeping  $B_1$  active. If  $X$  remains constant,  $U(t)$  slowly falls towards zero (but remains positive if  $a > b$ ). However, if there is a sudden decrease in  $X$ , i.e., if the bacterium begins to leave the region of high attractant concentration,  $U_1(t)$  can become negative and  $B_2$  is then activated, making the bacterium tumble until it again discovers an area with higher food concentration. It turns out that this simple model can adequately describe the motion of *E. coli* bacteria as illustrated by Figure 9.1, provided that the parameters  $a$  and  $b$  are properly chosen. Note that the overall performance of the bacteria has been reduced to a function of those two parameters; once the parameters have been set, the selection of behaviours is fully determined. The UF method, which will be described next, operates essentially in the same way.

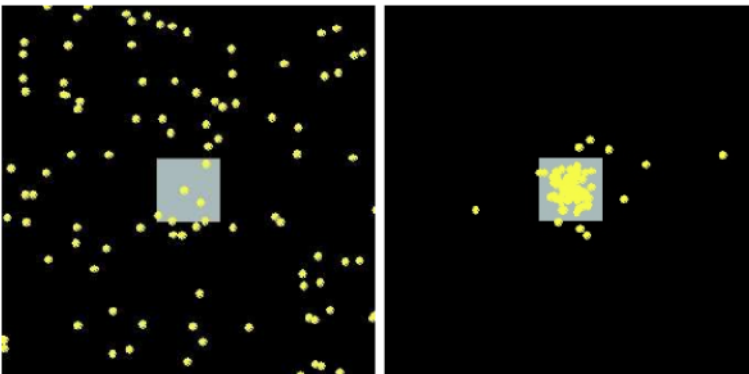

**Fig. 9.1** The motion of simulated *E. coli* bacteria based on the behaviour switch described in the main text. 100 bacteria were simulated and the parameters  $a$  and  $b$  were both equal to 1. The region of non-zero attractant concentration is shown as a square at the centre of each panel. The left panel shows the initial distribution of bacteria and the right panel shows the distribution at a later time

## 9.4 The Utility Function Method

The utility function (UF) method is a behaviour selection method that has been gradually developed over the last few years [3, 4, 6, 18]. The current version is a pure arbitration method, i.e., one that allows only a single behaviour to be active at any given time. Continuing developments, described briefly in Section 9.5, include the possibility of activating several behaviours simultaneously, provided that only a single behaviour controls any given actuator on the robot.

### 9.4.1 Motivation

The development of the UF method was based on the realisation that a common currency is needed in order to compare behaviours. The fact that this common currency must be available for all possible values of the robot's state variables motivates the introduction of utility functions (see below) taking the state variables as inputs.

Furthermore, unlike many other behaviour selection methods, the UF method has, from the beginning, been formulated with general applicability in mind. Thus, in the *development* of the method, no particular application has been considered. Once developed, however, the method has been applied successfully in several cases, most of which have involved motor behaviours [4, 18, 19].

As mentioned in Section 9.2, a drawback with many methods for behaviour selection is the requirement that the user should be able to set most, if not all, of the relevant parameters (determining the behaviour selection) by hand [3, 7]. A behaviour selection method should preferably include at least the possibility of some form of automatic parameter setting; such a procedure is included in the UF method in the form of evolutionary optimisation of the utility functions that determine the behaviour selection. On the other hand, it should also be noted that it is sometimes far from trivial to formulate an appropriate objective function for the optimisation procedure, implying that, in some cases, manual tuning of the behaviour selection system may be required.

### 9.4.2 Method

A central concept in the UF method is the robot's *state* that is obtained by measuring the values of a set of state variables ( $\mathbf{z}$ ). The state variables are of three different kinds:

*external variables* ( $\mathbf{s}$ ) such as the readings of IR sensors, sonars, cameras and laser range finders;

*internal physical variables* ( $\mathbf{p}$ ) such as the readings of a battery sensor; and *internal abstract variables* ( $\mathbf{x}$ ).

The internal variables (physical and abstract) measure the internal state of the robot. However, whereas the physical variables are, as their name implies, obtained through measurement of physical quantities, the abstract variables roughly correspond to signalling molecules (hormones) in biological systems.

Thus, the internal abstract variables (henceforth referred to as *hormone variables*) provide the robot with a rudimentary endocrine system, allowing a sort of short-term memory independent of the readings of physical quantities, internal or external. For example, an increase in the value of a hormone variable  $x$  in a given situation will alter the state of the robot and, depending on the dynamics of the variable (e.g., its decay rate), the robot might take a different action should it shortly thereafter find itself in the same situation again. The division of state variables into three categories is essentially based on the accuracy of measurement; external variables (sensor readings) are typically very noisy, whereas internal physical variables (such as the reading of a battery sensor), can normally be obtained with greater accuracy. Finally, the hormone variables can be specified with arbitrary accuracy.

The choice of state variables is certainly non-trivial. In simple cases where the robot is equipped with a few elementary sensors giving scalar readings such as IR proximity detectors or bumper sensors, the external variables can be taken as the set of all sensor readings. By contrast, in more complex cases involving, say, the readings of a (2D) laser range finder (typically giving an array of order  $10^3$  or more scalar values) or a camera (typically giving a matrix of, say,  $320 \times 240$  scalar values), some form of preprocessing must be carried out if the readings of those sensors are to provide a manageable number of state variables. These issues will be discussed briefly in connection with the description of the extended method in Section 9.5. Though for now, it will be assumed that the state variables are defined only by simple sensors, giving scalar readings. Note that this restriction does not exclude the possibility of using more complex sensors in the robot, such as laser range finders, as long as the readings of those sensors are not used for the definition of state variables.

Mathematically, the utility function for behaviour  $B_i$  is specified as  $U_i = U_i(\mathbf{s}, \mathbf{p}, \mathbf{x})$ . In principle, any functional form could be used, e.g., a Fourier expansion, a polynomial expansion, etc. Practical experience with the UF method has shown that it is commonly sufficient (at least for the applications considered so far) to use low-degree polynomials. Hence, a polynomial *ansatz*<sup>7</sup> (with a given polynomial degree  $d$ ) is used. As an example, the ansatz for a utility function  $U_i = U_i(s, p)$  of two variables, and with polynomial degree  $d = 2$  will take the form:

---

<sup>7</sup> In physics and mathematics, an *ansatz* is an educated guess that is verified later by its results. After an ansatz has been established, the equations are solved for the general function of interest.

$$U_i(s,p) = a_{00}^{(i)} + a_{10}^{(i)} s + a_{01}^{(i)} p + a_{20}^{(i)} s^2 + a_{11}^{(i)} sp + a_{02}^{(i)} p^2 \quad (9.6)$$

where the  $a_{jk}^{(i)}$  terms are constant coefficients to be determined<sup>8</sup>.

Note that not all utility functions must depend on all state variables. In many cases, the utility functions depend only on a subset of the available state variables, and different utility functions may use different subsets of the variables as inputs.

Behaviour selection is simple in the UF method: At any given time, the utility values  $U_i$  are computed for each behaviour, using the most recent values of the state variables as inputs, and the behaviour  $i_{\text{sel}}$  with the highest utility value is selected for activation. Thus:

$$i_{\text{sel}} = \operatorname{argmax}_i (U_i). \quad (9.7)$$

The problem, of course, is to determine the utility functions, i.e., to set the constants  $a_{jk}^{(i)}$  for all utility functions. Furthermore, the dynamics of the hormone variables must be specified as well since, unlike the other variables, their values are not obtained through measurements of physical quantities. In the early stages of the development of the UF method, the specification of hormone variable dynamics was carried out by hand [3]. However, in later applications, the constants determining the hormone variable dynamics have been included in the optimisation procedure as well. Thus, before describing the general optimisation carried out in the framework of the UF method, we shall consider the use of hormone variables.

### *Hormone variables*

As discussed above, hormone variables may, for example, serve to provide an otherwise completely reactive robot with a simple form of short-term memory. The following example is somewhat lengthy, but will hopefully help to motivate the introduction of hormone variables.

Consider a reactive robot equipped with two behaviours, namely, *path navigation* ( $B_1$ ) and *obstacle avoidance* ( $B_2$ ). Leaving aside the problem of localisation, i.e., assuming, in order to simplify the example, that the robot can determine its exact position using (unrealistically) noise-free odometry, the purpose of  $B_1$  is to generate and follow a path from the current location to some target location. By contrast,  $B_2$  should be activated if, say, the robot encounters a moving obstacle along its path. Furthermore, assume that the robot is equipped with a single, wide-angle proximity detector, the output of which decreases with increasing distance between the robot and an obstacle, out to a maximum detection range. Assuming that the UF method is used for selecting behaviours, one must specify the utility functions. Since there are only two behaviours available and all

---

<sup>8</sup> In general, the number of subscripts in the constants determining a utility function equals the number of variables used in the function.

that matters is the relative utility values, it implies no restriction to set  $U_1$  to zero, i.e.,:

$$U_1 \equiv a_0^{(1)} = 0. \quad (9.8)$$

Furthermore, the ansatz for  $U_2$  may include a dependence on the reading  $s$  of the proximity detector, for example, as:

$$U_2(s) = a_0^{(2)} + a_1^{(2)} s \quad (9.9)$$

where  $a_0^{(2)}$  and  $a_1^{(2)}$  are constants to be determined. If no obstacles are detected,  $B_2$  should, of course, be inactive. Thus, the constants must satisfy  $a_0^{(2)} < 0$  and  $a_1^{(2)} > 0$ . Now, when an obstacle appears, the exact moment at which the robot switches from  $B_1$  to  $B_2$  depends on the values of the two constants and, as soon as  $s$  drops to a sufficiently low value  $s_{\min} = -a_0^{(2)} / a_1^{(2)} > 0$ , then  $B_1$  is activated again.

However, with  $s$  as the only available state variable, several problems may occur. For example, the reactivation of  $B_1$  may cause the robot to approach the obstacle again (assuming that the obstacle moves slowly so that it remains in the vicinity of the robot), leading to an increase in  $s$  and, therefore, another activation of  $B_2$ , followed by a quick reactivation of  $B_1$  soon thereafter and so on. Thus, as a result of its completely reactive behaviour selection system, the robot might experience rapid behaviour swapping, resulting in poor overall performance.

Comparing this with biological organisms (even very simple ones), it is easy to see that the decision-making system of the robot is missing a crucial component, the ability to incorporate past experience. Typically, a biological organism following a close encounter with a dangerous obstacle will find itself in a state of sensitisation, such that it will react particularly strongly to another encounter with the same obstacle. Further, the memory (however brief) of the encounter, will allow the organism to extend the period of evasion beyond the duration of the direct sensory input.

Returning to the robot, such characteristics can be modelled using a hormone variable. Thus, consider a modified utility function for  $B_2$ , of the form:

$$U_2 = a_{00}^{(2)} + a_{01}^{(2)} s + a_{10}^{(2)} x \quad (9.10)$$

where  $x$  denotes the hormone variable.

The procedure for specifying the hormone variable dynamics is described below. For now, let us assume that  $x$  is equal to zero as the robot begins its operation (navigating using  $B_1$ ) and that, as a result of the robot activating  $B_2$ ,  $x$  is raised instantaneously (to 1, say), and then falls off slowly (with time) towards 0. It is easy to see that if the constants determining  $U_2$  are properly set, the increase in  $x$  will allow the robot to maintain  $B_2$  active (since  $U_2 > U_1$ ) even after  $s$  drops to 0, thus allowing it to clear the obstacle completely without behaviour swapping.

Furthermore, the robot will effectively be sensitised should it encounter another obstacle before  $x$  drops to zero: The sensory reading  $s$  needed to cause a switch to  $B_2$  will then be lower than if  $x$  had been equal to zero.

### *Hormone variable specification*

Due to the abstract nature of hormone variables, the specification of their dynamics cannot be derived from the physical properties of the robot or its environment. To some extent, the specification is arbitrary; it is up to the optimisation procedure described below to make use of the hormone variables in the utility functions in the best possible way, which includes the possibility of not using them at all if the information they provide turns out to be irrelevant<sup>9</sup>. Preferably, however, the hormone variables should provide some useful information, as in the example considered above.

Through the development of the UF method, several different procedures have been employed for specifying the dynamics of hormone variables. One such procedure which has been found to represent a suitable trade-off between the desire to limit the complexity of the representation and the requirement that the hormone variables should convey some useful information will now be described. In this procedure, the variation of each hormone variable  $x_i$ , in a given (active) behaviour  $B_j$  is determined by the five parameters  $\Delta x_{ij}^{\text{in}}$ ,  $\Delta x_{ij}^{\text{out}}$ ,  $\Gamma_{ij}$ ,  $\tau_{ij}$  and  $x_i^{\text{max}}$ . Upon activation of  $B_j$ ,  $x_i$  is set according to:

$$x_i \leftarrow x_i + \Delta x_{ij}^{\text{in}}. \quad (9.11)$$

If  $x_i$  exceeds  $x_i^{\text{max}}$ , it is set to  $x_i^{\text{max}}$ . Similarly, if  $x_i < 0$ , it is set to 0. Upon deactivation of  $B_j$  (i.e., an event just preceding the activation of some other behaviour  $B_k$ , remembering that exactly one behaviour is active at any given time, in the current version of the UF method),  $x_i$  is set as:

$$x_i \leftarrow x_i + \Delta x_{ij}^{\text{out}} \quad (9.12)$$

with similar limitations as in the case of activation.

Thus, the value of  $x_i$  may vary discontinuously when a behaviour switch occurs. When  $B_j$  is active,  $x_i$  varies according to:

---

<sup>9</sup> The user must of course decide how many hormone variables should be used. Since the optimisation procedure can choose to use some, or all, of the hormone variables, this specification rarely presents a problem. Including too many hormone variables has no adverse effects except, perhaps, slowing down the optimisation procedure a little.



$$\frac{dx_i}{dt} = \frac{\Gamma_{ij} x_i^{\max} - x_i}{\tau_{ij}}. \quad (9.13)$$

$\Gamma_{ij}$  is an integer parameter taking the value 0 or 1. If  $\Gamma_{ij} = 1$ ,  $x_i$  rises exponentially towards the maximum level  $x_i^{\max}$ . If instead  $\Gamma_{ij} = 0$ ,  $x_i$  falls off exponentially towards the minimum level ( $= 0$ ). In the example above, the parameters were:

$$\begin{aligned} \Delta x_{11}^{\text{in}} &= 0, \Delta x_{12}^{\text{in}} = 1, \Delta x_{11}^{\text{out}} = 0, \Delta x_{12}^{\text{out}} = 0 \\ \Gamma_{11} &= \Gamma_{12} = 0, \tau_{11} = \tau_{12} = \tau_1 \text{ (for some positive value of } \tau_1) \\ \text{and } x_1^{\max} &= 1. \end{aligned}$$

In a robot with  $m$  hormone variables and  $n$  behaviours, the total number of parameters determining the variation of the hormone variables equals  $N_h = m(4n + 1)$ . Note that  $N_h$  typically overestimates the number of parameters that must be determined. If, as in the example above, all hormone variables are specified with  $\Gamma_{ij} = 0$  (exponential fall-off rather than increase),  $x_1^{\max} = 1$  and, with  $\tau_{ij} = \tau_i$  (independent of  $j$ ), the number of parameters is reduced to  $m(2n + 1)$ .

### 9.4.3 Optimisation Procedure

Like any behaviour selection method, the UF method requires that certain parameters should be set to appropriate values. In the case of the UF method, those parameters are (1) the constants determining the utility functions, and (2) the constants determining the variation (with time) of the hormone variables. Setting all those parameters by hand can often be a daunting task, particularly in cases involving several behaviours. Thus, as indicated above, the UF method includes a procedure for *optimisation* based on an evolutionary algorithm to determine appropriate parameter values.

Of course, the specific choice of optimisation algorithm is somewhat arbitrary and should not be seen as an integral part of the method. For example, other optimisation methods such as particle swarm optimisation or simulated annealing could equally well have been used. An advantage with evolutionary optimisation is that the method can easily be modified to cope with structures of variable size, which will be relevant in cases where, for instance, the (polynomial) degree  $d$  of the utility functions is allowed to vary during optimisation. In cases where  $d$  is fixed, the evolutionary algorithm used by the UF method is reduced to a standard genetic algorithm (GA) [22], with real-number encoding.

However, once an optimisation procedure has been added, two questions appear, namely, (1) what should be the optimisation criterion, i.e., the objective function? (also known as the fitness function, in connection with evolutionary

optimisation) and (2) how should one evaluate any given parameter setting? ( i.e., a particular set of utility functions and a given specification of the hormone variable dynamics).

### *Specifying an objective function*

The solution to the first problem will naturally vary from problem to problem and, in the current version of the UF method, the objective function is scalar, i.e., multi-criteria optimisation is not considered even though the method certainly can be extended to include such features. Thus, the objective function must be specified as a single scalar, summarising the task of the robot. This is not always easy to do. However, in many applications, the robot will have one specific task. Any other actions carried out by the robot, such as localisation and obstacle avoidance, are not ends in themselves (and therefore need not be made part of the objective function).

As a specific example, consider the task of transporting objects between a sequence of target points (denoted A, B, C,...) in an arena in a given maximum time  $T$ . A robot given this task would, for example, be equipped with a navigation behaviour that generates a path (using for instance the A\* algorithm [20]) from the current location to the next target point. In order to achieve the first goal of reaching point B (starting from point A) and then moving on to point C etc., most likely the robot will have to avoid some obstacles along the way<sup>10</sup>, and it must also continuously keep track of its pose (position and heading). Now, from the user's point of view, the exact manner in which the robot carries out these auxiliary tasks is not relevant; all that matters is that the robot is able to reach the target points B, C, etc. in a reliable way.

Thus, a suitable fitness function for this problem (assuming maximisation as is common in evolutionary algorithms) may simply be one that gives an increment of 1 for each target point reached and, finally, adds a score based on the distance to the next target point in the sequence at the end of the evaluation (brought about either by a collision or simply because the  $T$  seconds of evaluation time have elapsed). Thus, mathematically, the fitness function may take the form:

$$f = j + e^{-cd} \quad (9.14)$$

where  $j$  is the number of target points reached,  $c$  is a positive constant and  $d$  is the distance to the next point (the  $(j + 1)$ th point) in the sequence at the end of the evaluation. If no target point is reached as is typically the case in the early stages of optimisation,  $j = 0$ . The exponential term provides the optimisation method with a smooth gradient towards better performance.

At first glance, the fitness measure given in Equation 9.14 may not seem to be sufficient, as it does not specify that the robot must keep track of its pose (through activation of a localisation behaviour) and also avoid obstacles (through activation

---

<sup>10</sup> In case of a collision, the evaluation of a robotic brain is normally terminated.

of a behaviour that does so). However, it is easy to realise that if the robot *does not* carry out those tasks, it is very unlikely that it will reach the target point and it will therefore obtain a rather low fitness value. Thus, the fitness measure *implicitly* requires that the robot should, from time to time, activate other behaviours than the task-achieving navigation behaviour. This, in turn, implies that the optimisation procedure must set the utility functions in such a way that those auxiliary behaviours are activated when appropriate.

### *Simulations versus real robots*

As for the second problem, it should be noted that the search space is typically quite large. For example, the number of parameters  $N_p$  needed to specify a general polynomial of  $k$  variables and with degree  $d$  is given by:

$$N_p = \binom{k+d}{d}. \quad (9.15)$$

Consider now a robot with  $n$  behaviours, each of which is associated with a polynomial utility function taking  $k_i$  variables as inputs,  $i = 1, \dots, n$ . Including also the number of parameters  $N_h$  needed to specify the  $m$  hormone variables, the total dimensionality  $v$  of the search space (i.e., the number of parameters) will be:

$$v = \sum_{i=1}^n N_p(i) + N_h = \sum_{i=1}^n \binom{k_i+d}{d} + m(4n+1). \quad (9.16)$$

As a specific example, consider a case with  $n = 3$  behaviours whose utility functions take  $k_i \equiv k = 4$  ( $i = 1, \dots, 3$ ) variables as inputs of which  $m = 2$  are hormone variables. Assuming that the degree  $d$  of the utility functions is equal to two, the dimensionality of the search space will be:

$$v = 3 \binom{6}{2} + 2 \times 13 = 71. \quad (9.17)$$

Thus, even for this rather simple case with only three behaviours, the dimensionality of the search space is quite large, implying that whichever optimisation method is used, a large number (thousands or more) of evaluations of the objective function will have to be carried out. This, in turn, essentially rules out the possibility of running the optimisation procedure in a real robot which, per definition, operates in real time and will also be prone to mechanical failures and other problems. Instead, in the UF method, simulations are used that typically run much faster than real time.

However, as is well known in robotics [21], using simulations has certain drawbacks, the most serious being that no simulation, however advanced, can

represent reality perfectly. Obviously, noise can (and should) be added to the simulator, but the behaviour of the simulated robots will still only approximate the performance of a real robot. Thus, the optimised behaviour selection system obtained in simulation should be considered as a first version which must then be fine-tuned further in the real robot. On the other hand, the discrepancy between the real and simulated robots should not be exaggerated. Some robotic components, e.g., laser range finder sensors, can be simulated quite accurately and the amount of fine-tuning needed when transferring results to a real robot is therefore manageable in many cases.

### *Generating the behaviour selection system*

The purpose of the optimisation procedure is to set the parameters determining the behaviour selection system, i.e., the utility functions and the hormone variable dynamics, so as to achieve the best possible performance as measured by the objective function described above. In order to do so, one needs a simulator capable of simulating both the robot (with its sensors and actuators and, of course, the behaviours and the behaviour selection system) as well as its interaction with objects in the arena. Furthermore, the simulator must also be equipped with an evolutionary algorithm (or some other optimisation algorithm), which will evaluate different behaviour selection systems during the course of optimisation. Such a simulator has been written [6] for the UF method.

### *Summary of the UF method*

The method can now be summarised as follows:

1. Specify the configuration for the simulations:
  - a) Define the characteristics of the robot, i.e., its shape as well as its sensors and actuators.
  - b) Define a set of suitable behaviours for the task at hand, for example *A\*-navigation* and *obstacle avoidance*.
  - c) Define a set of state variables, e.g., the readings of IR proximity sensors and a few hormone variables.
  - d) Define the structure of the utility functions, i.e., the polynomial degree and the input variables (for each function).
  - e) Define the arena in which the robot is supposed to operate.
  - f) Define a suitable objective function (fitness function).
2. Generate a random population of behaviour selection systems specified by the parameters determining the utility functions together with the parameters specifying the hormone variable dynamics.
3. Run the optimisation procedure:
  - (a) Evaluate the population of behaviour selection systems:

- (i) For each member of the population, upload the corresponding behaviour selection system (utility functions and hormone variable dynamics) onto the simulated robot.
  - (ii) Evaluate the robot, with the behaviour selection system provided in the previous step by running the simulator for a maximum of  $T$  s (or until some other event, such as a fatal collision, terminates the evaluation).
  - (iii) Store the fitness value, i.e., the performance measure, of the behaviour selection system.
- (b) Generate new behaviour selection systems through the evolutionary processes of selection (in proportion to fitness), crossover, and mutation.
- (c) Repeat Steps 3(a) and 3(b) until a user-specified termination criterion has been reached.

In Step 2, the set of parameters is specified in the form of an artificial genome in which each gene represents one parameter. Commonly, two chromosomes are used in the genome, one for representing the coefficients determining the utility functions and one for determining the hormone variable variation, as illustrated in Figure 9.2. If the number of parameters is constant, as is assumed here, Step 3(b) is straightforward and proceeds as in a standard GA [22].

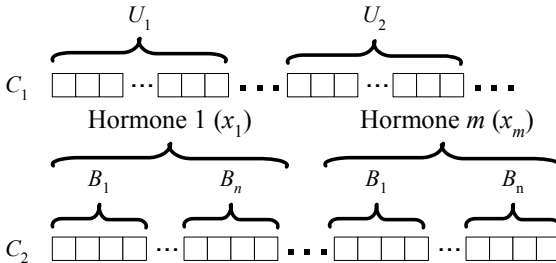
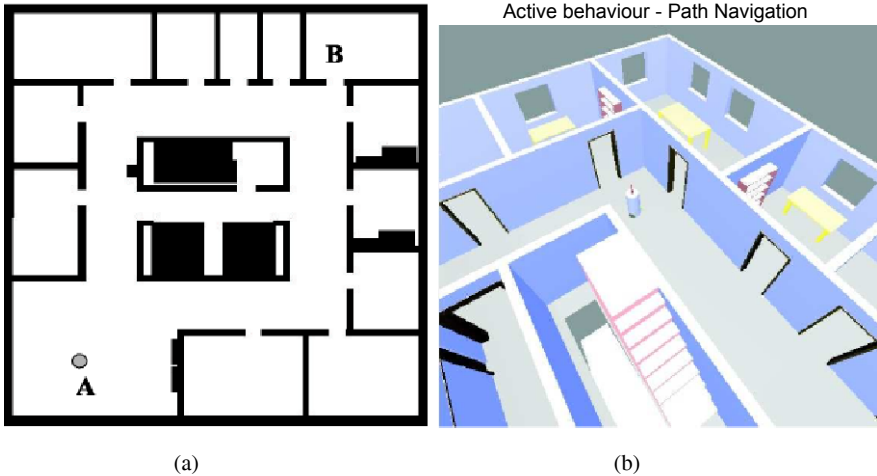

**Fig. 9.2** A schematic illustration of the two chromosomes determining the utility functions and the hormone dynamics. The upper chromosome ( $C_1$ ) encodes the utility functions. Each box in  $C_1$  represents the coefficient for one polynomial term<sup>11</sup>. The lower chromosome ( $C_2$ ) encodes the hormone dynamics. Here, each set of four boxes represents the parameters  $\Delta x_{ij}^{in}$ ,  $\Delta x_{ij}^{out}$ ,  $\Gamma_{ij}$  and  $\tau_{ij}$  that determine the variation of one hormone variable during periods of activity of one particular behaviour (The parameters  $\Delta x_i^{max}$  were not included in the chromosomes, as their values are typically set by hand, see the example presented in Section 9.4.4)

<sup>11</sup> See also Equation 9.6

### 9.4.4 Application Example – a Transportation Task

The UF method has been tested in several different applications. In order to clarify the description of the method, we shall consider a specific example, namely, a transportation task in which the robot is required to transport objects between given points in an arena representing a typical office environment<sup>12</sup>.



**Fig. 9.3** (a) A schematic illustration of the transportation robot in a typical arena. The task of the robot, shown as a disk near the lower left corner of the arena, is to transport objects from point A to point B (arbitrarily chosen). (b) A 3D snapshot from the simulator, showing the robot in action. The laser range finder is attached at the top of the pole protruding from the cylindrical body of the robot

The arena in which the (simulated) robot operates is shown in Figure 9.3. The centre of the arena contains a staircase and elevators. These two regions are off-limits for the robot. Thus, the robot is constrained to move in the corridors and offices. In the simulations, a differentially steered robot with cylindrical cross section was used. The robot was equipped with wheel encoders (for odometry), touch sensors, and a laser range finder (LRF) mounted on a pole (for odometry recalibration, i.e., localisation), see Figure 9.3 (b). During the simulations, noise was added both to motor torques and sensor readings.

#### Behaviours

In the experiments carried out in connection with this problem, three behaviours were included in the behavioural repertoire, namely, *path navigation* ( $B_1$ ), *localisation* ( $B_2$ ), and *obstacle avoidance* ( $B_3$ ). In  $B_1$ , the robot navigated through a

<sup>12</sup> The presentation here is quite brief. For a more complete description regarding this particular application, see the work by Wahde and Pettersson [4, 19].

sequence of waypoints generated by the combined use of a grid-based map and an A\* search algorithm [20]. The last waypoint coincided with the target location. Whenever the robot reached a target, a new target location was generated (and thus a new sequence of waypoints). Furthermore, if  $B_1$  was deactivated, a new sequence of waypoints was generated upon its reactivation, connecting the current (estimated) position to the target location. It should be noted that  $B_1$  relies solely on odometry.

Consequently, in order to successfully navigate to a designated target, the estimated position of the robot must be sufficiently accurate so as to avoid large deviations from the intended path which may lead to collisions with obstacles such as walls or tables. It is the purpose of the *localisation* behaviour ( $B_2$ ) to maintain odometric accuracy by recalibrating the odometric estimate of the robot's position and heading.  $B_2$  is based on the readings of the (2D) LRF which is mounted on a pole extending vertically from the top surface of the robot to avoid including moving objects (if any) in the scan. The basic idea is to match the current readings of the actual LRF to the readings of a virtual LRF placed (virtually) in various locations in the map in the vicinity of the estimated position of the robot<sup>13</sup>, and then to generate a new position estimate using the best-matching virtual LRF reading. The behaviour is described in detail in [23].

In contrast with the two behaviours just described, the obstacle avoidance behaviour is very simple: When activated by the behaviour selection system, this behaviour simply sets the speed of the motors to equal, negative values so that the robot will move backwards in a straight line. Note that it is the job of the behaviour selection system both to activate the behaviour by raising the corresponding utility value as a result of, for example, a non-zero reading of one or several touch sensors, and to deactivate it by lowering its utility as soon as the touch sensors no longer are in contact with an obstacle.

### *Behaviour selection*

In this investigation, two hormone variables  $x_1$  and  $x_2$  were introduced, and these were the only state variables used for  $B_1$  and  $B_2$ . For  $B_3$ , the readings of the three touch sensors ( $s_1$ ,  $s_2$ , and  $s_3$ ) were used as state variables, together with the two hormone variables. Thus, the utility function polynomials were specified as:

$$U_1 \equiv U_1(x_1, x_2) = a_{00}^{(1)} + a_{10}^{(1)} x_1 + \dots \quad (9.18)$$

$$U_2 \equiv U_2(x_1, x_2) = a_{00}^{(2)} + a_{10}^{(2)} x_1 + \dots \quad (9.19)$$

and

---

<sup>13</sup> Thus, the localisation behaviour assumes implicitly that the odometry has not drifted too much. Note, however, that it is up to the behaviour selection system to activate the localisation behaviour at the correct time.

$$U_3 \equiv U_3(x_1, x_2, s_1, s_2, s_3) = a_{00000}^{(3)} + a_{10000}^{(3)}x_1 + \dots \tag{9.20}$$

for  $B_1$ ,  $B_2$  and  $B_3$ , respectively. Following the results obtained in earlier studies [19], the polynomial degree was set to 3. The maximum value of the hormone variables ( $x^{\max}$ ) was set to 1 for both variables, eliminating two parameters from the optimisation procedure.

*Simulations and results*

In each evaluation, the robot was allowed to move for  $T = 150$  s. The time step length was set to  $dt = 0.01$  s, and simulations were terminated if the body of the robot collided with an object (e.g., a wall), but not, of course, in cases where only the touch sensors were in contact with the object.

In each time step, the values of the five state variables  $x_1$ ,  $x_2$ ,  $s_1$ ,  $s_2$ , and  $s_3$  were obtained, and the utility values  $U_1$ ,  $U_2$ , and  $U_3$  were calculated. Then, the robot activated (or kept active) the behaviour with the highest utility value.

During optimisation, the parameters determining the variation of the hormone variables  $x_1$  and  $x_2$ , as well as the parameters specifying the utility functions were encoded in two chromosomes as was illustrated in Figure 9.2. Thus, the behaviour selection system used in a given evaluation was obtained in a decoding step, during which the parameters were read off from the chromosomes. In this application, the total number of parameters was equal to 100.

A fairly standard EA (implemented in the simulator) was used for optimising the behaviour selection system. The population size (i.e., the number of behaviour selection systems being evaluated) was set to 30, and the crossover probability  $p_{\text{cross}}$  to 0.50. The mutation rate was equal to 0.03. The tournament selection parameter, i.e., the probability of selecting the better of the two individuals in a tournament, was equal to 0.70. The fitness measure was taken simply as the number of waypoints reached by the robot during its evaluation.

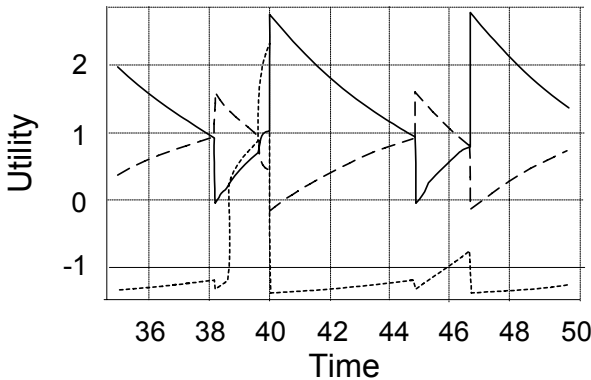

**Fig. 9.4** Variation in the utility values between  $t = 35$  and  $t = 50$  for a re-evaluation of the best individual found during optimisation.  $U_1$ ,  $U_2$ , and  $U_3$  are shown as solid, dashed, and dotted lines, respectively



After optimisation, the resulting robot was capable of carrying out the intended task, switching between the three available behaviours at the correct moment. The robot spent about 27 % of its time in  $B_2$  (localisation) and almost all the remaining time in  $B_1$  (navigation). On rare occasions, the obstacle avoidance behaviour was activated. An example of the variation (with time) of the utility functions during a typical run is shown in Figure 9.4. The results of the simulations are currently being implemented in a real robot which is very similar to the robot used in the simulations, except that infrared proximity sensors will be used instead of touch sensors.

## 9.5 Ongoing Work

### 9.5.1 *Extended UF Method*

The current version of the UF method described above is a pure arbitration method, i.e., it allows only a single behaviour to be active at any given time. In tasks centred on locomotion, such as navigation tasks, this approach is normally sufficient since a given actuator can only carry out one particular movement at any given time. However, in more complex tasks, a robot may be equipped with several non-motor (cognitive) behaviours that may very well run concurrently with a motor behaviour. Thus, work is underway to allow parallel activation of more than one behaviour. However, allowing parallel activation of behaviours makes the procedure of activating appropriate processes even more complicated and there are still many unresolved issues that must be solved before the extended utility function (EUF) method is completed.

### 9.5.2 *Data Preprocessing and Artificial Emotions*

The issue of representing states (of a robot) in an appropriate way is a problem that affects all methods for behaviour selection. The number of options available to a decision-maker must at any given instant be reduced to a manageable number and, as suggested by Damasio [24], one function of emotions may be to act as a filter, discarding many irrelevant options. The role of emotions in decision-making has indeed been considered in robotics as well, see, e.g., [12].

In order to include such ideas in the UF method, one may introduce a preprocessing system that takes as input all the raw data that, in the case of a robot, may consist of (say) laser range finder data (perhaps thousands of distance measurements, in various directions), visual data (e.g., an image of, say,  $320 \times 240$  grey scale values), auditory data, IR sensor data etc. The preprocessing system

would then reduce the number of variables from several thousands to, say, 10 or fewer. The variables would finally be used as the state variables determining the utility values for all behaviours; the reduction to a few variables would thus decrease the size of the space of possible decisions.

As an example, the preprocessing system may contain a multi-layered neural network that takes an image as input and generates a single scalar output, determining, for example, the degree of congestion (as detected from the image) in front of the robot<sup>14</sup>.

## References

1. Arkin RC (1998) Behaviour-based robotics, The MIT Press
2. Pirjanian P (1999) Behaviour-coordination mechanisms – State-of-the-art, Institute for Robotics and Intelligent Systems, University of Southern California, Technical report IRIS-99-375
3. Wahde M (2003) A method for behavioral organization for autonomous robots based on evolutionary optimisation of utility functions, *Journal of Systems and Control Engineering*, **217** (4); 249–258
4. Wahde M, Pettersson J (2006) A general-purpose transportation robot: An outline of work in progress, Proc. 15th IEEE Int. Symposium on Robot and Human Interactive Communication (RO-MAN 06); 722–726.
5. Bryson JJ (2007) Mechanisms of action selection: Introduction to the special issue, *Adaptive Behaviour*, **15** (1); 5–8
6. Pettersson J, Wahde M (2007) Uflibrary: A simulation library implementing the utility function method for behavioural organization in autonomous robots, *Int. J. on Artificial Intelligence Tools*, **16**; 507–536
7. Blumberg B (1994) Action-selection in Hamsterdam: Lessons from ethology, Proc. 3rd Int. Conf. on the Simulation of Adaptive Behaviour:108–117
8. Bergener T, Steinhage A (1998) An architecture for behavioural organization using dynamical systems, 3rd German Workshop on Artificial Life; 31–42
9. Brooks R (1986) A robust layered control system for a mobile robot, *IEEE J. of Robotics and Automation*, **RA-2** (1); 14–23
10. Maes P (1989) How to do the right thing, *Connection Science Journal*, **1** (3); 291–323
11. Khatib O (1985) Real-time obstacle avoidance for manipulators and mobile robots, Proc. IEEE Int. Conf. on Robotics and Automation; 500–505
12. Gadanho SC, Hallam J (2001) Emotion-triggered learning in autonomous robot control, *Cybernetics and Systems*, **32**; 531–559
13. McFarland D (1998) *Animal Behaviour: Psychobiology, Ethology and Evolution*, 3rd ed., Prentice Hall
14. McFarland D, Spier E (1997) Basic cycles, utility, and opportunism in self-sufficient robots, *Robotics and Autonomous Systems*, **20**; 179–190
15. Bryson JJ, Prescott TJ, Seth AK (Eds.) (2007) *Modelling Natural Action Selection*, Proc. of an International Workshop, AISB Press
16. von Neumann J, Morgenstern O (1953) *Theory of Games and Economic Behaviour*, 3rd ed., Princeton University Press
17. Staddon JER (2001) *Adaptive Dynamics: The Theoretical Analysis of Behaviour*, MIT Press

---

<sup>14</sup> Work along these lines is also currently underway in the author's research group.

18. Pettersson J, Wahde M (2006) Improving generalization in a behavioural selection problem using multiple simulations, Proc. SCIS & ISIS 2006, Tokyo; 989–994
19. Pettersson J (2006) Generation and organization of behaviors for autonomous robots, Ph.D. dissertation, Chalmers University of Technology
20. Hart PE, Nilsson NJ, Raphael B (1968) A formal basis for the heuristic determination of minimum cost paths in graphs, IEEE Trans. on Systems Science and Cybernetics, **SSC-4** (2); 100–107
21. Jakobi N, Husbands P, Harvey I (1995) Noise and the reality gap: The use of simulation in evolutionary robotics, Lecture Notes in Computer Science, **929**: 704–720
22. Holland J (1992) Adaptation in natural and artificial systems, MIT Press
23. Pettersson J, Hartono P, Wahde M (2007) A behaviour module of odometry recalibration in autonomous robots, Proc. 4th Int. Symp. on Autonomous Minirobots for Edutainment and Research, AMiRE2007
24. Damasio A (1994) Descartes' error: Emotion, reason and the human brain, Avon Books

# Chapter 10

## Force Sensing in Medical Robotics

Kaspar Althoefer, Hongbin Liu, Pinyo Puangmali, Dinusha Zbyszewski,  
David Noonan and Lakmal D Seneviratne<sup>1</sup>

### 10.1 Background

Medical robotics is at a relatively early stage compared to industrial robotics, which has a long historical background dating back to the 1960s when the first computer controlled manipulators were installed [1]. It is apparent that the number of medical robots installed for practical uses today is much smaller than the number of industrial robots employed in manufacturing. However, after various recent achievements in medical robotic research, people have begun to recognise the distinctive advantages of using robots for medical purposes. The main reasons that have drawn much attention to robotic systems results from their capability in carrying out a variety of surgical and other medical tasks with high accuracy and repeatability, and their ability to provide surgeons with enhanced visual feedback. Owing to their capabilities and benefits in clinical areas, the research and deployment of robots for medical applications has increased considerably over the last decade. To date, there have been a number of robots used in complex medical interventions including neurosurgery, cardiac surgery, orthopaedic surgery, urological surgery, bariatric surgery, prosthetic implantation, and rehabilitation. Today, medical robotic technology has dramatically improved, resulting in an increase of medical robots on the market along with their applications in real clinical scenarios. In the future, it is expected that robots will play very important roles in modern medical diagnosis, surgery, rehabilitation, *in vivo* inspection and drug delivery.

Orthopaedic surgery and neurosurgery were the very first clinical fields in which robots were employed [2]. In both cases, the target anatomy, either bone or neurological tissue, is assumed to be non-compliant and robotic systems initially demonstrated their usefulness as positioning devices; guiding surgical tools to desired locations within the operative site and exploiting their capabilities for conducting operations with a greater precision and repeatability than was

---

<sup>1</sup> King's College London, UK

previously possible using hand-held instruments. Integrated with an image-guided system, the computer software enables the robot's trajectories to be planned based on preoperative CT (computed tomography) /MRI (magnetic resonance imaging) images before movements to the desired target are executed. Due to the high stiffness of the robotic structure and the reliable performance of the computer-based controller, robots have a huge potential in providing steady positioning, accurate guidance, and intra-operative localisation capabilities. This allows complex surgical interventions which usually require very high accuracy for delicate tool manipulation to be carried out very effectively. Currently, accuracy in surgical tool manipulation is much superior to that in the last decade. Based on a well-defined preoperative planning and computer-guided control strategy, robots can perform surgical tasks such as, inserting a needle, cutting and drilling into bone with submillimetre accuracy [3].

Another application that has shown to be successfully enhanced through the introduction of robotics is minimally invasive surgery (MIS) (also called keyhole surgery). Before the arrival of medical robots in this field, surgeons faced many difficulties in performing procedures during MIS, including reduced dexterity of the surgical tools, reversal of directions *in vivo* due to the fulcrum effect created by the constraint of the small insertion holes (trocar ports) and the inability to directly visualise the operative site in 3D. Moreover, sensing the tool-tissue interaction remotely (i.e., outside the body) is severely impaired by the friction of the tool insertion port, inertia of the tool shaft, and reaction forces between tool shaft and the insertion port.

Master-slave robotic systems, such as the Zeus<sup>®</sup> Surgical System from Computer Motion, Inc., and the da Vinci<sup>®</sup> Surgical System from Intuitive Surgical, Inc., have been introduced to solve some of these problems by incorporating multiple degrees of freedom at the surgical tool tip and providing the surgeon with a more intuitive control interface. As a consequence, the 7-degrees of freedom available to the human operator (x,y,z translation; roll, pitch, yaw rotation and grip) are replicated by the robot *in vivo*. However, because current robotic systems do not have interaction force sensing capabilities, the learning curve for performing delicate procedures such as suturing and knot-tying increases significantly. Additionally, the surgeon loses the ability to perform organ palpation for the detection of abnormalities including tumours, nerves, vessels or other tissue stiffness variations, a practice commonly conducted during open surgery.

To overcome the problems introduced by this lack of force feedback, various sensing techniques have been developed to detect tissue interaction forces and transfer the force sensing information to the surgeon [4]. This paper provides an overview of emerging tool-tissue force sensing methods and recently developed force sensor prototypes, and then discusses applications of force sensing in medical robotic applications including haptic feedback and soft tissue identification via tissue-tool interaction.

## 10.2 Force Sensing Techniques in Medical Robotics

There are several force sensing methods that can be used in the field of medical robotics. The following overview of force sensing techniques is not exhaustive, but shows the most commonly employed force sensing methods and recent developments with respect to medical applications.

One approach to force sensing is to measure the amount an elastic component is deformed in response to an applied force. The employed sensor then operates based on the principle of detecting displacement variations. Utilising knowledge of the elastic properties of the deformable material (such as the inherent spring constant), the applied force can be computed as a function of the measured displacement. There are a number of displacement sensors that can be used to accurately measure the displacement when the elastic component is deformed, including digital encoders, potentiometers, linear variable differential transformers (LVDT) and optical fibre-based sensors. The elastic component can be made of elastic materials such as a spring or rubber, or can be made of a proportional-derivative servomechanism with similar “elastic” properties [4, 5].

In the case that a medical device has a motor-actuated joint, it is possible to estimate applied forces by measuring the current of the motor since the value of the generated torques or forces is proportional to the armature current of the motors over a wide range [6]. Based on this principle, Tholey *et al.* designed and developed a laboratory prototype laparoscopic grasper which estimates the grasping force as a function of the current supplied to the joint motor [7]. Because the device does not use a force sensor to measure the magnitude of the force, the manufacturing cost could be kept low. Unfortunately, due to friction of joints, inertia of all linkages, backlash and other non-linear effects including changes of the motor brush conductivity and winding resistance, the device does not show good accuracy in force estimation.

Similar to the current-based force sensing method in a tool actuated by electrical motors, pressure-based sensing methods can be employed in medical tools whose joints are driven by pneumatic actuators in order to estimate the forces at the tool’s end-effector with relatively high accuracy and sensitivity. This was demonstrated by Tadano *et al.* with a 4-DOF pneumatic driven forceps [8]. By making use of a neural network estimation scheme, the system possesses good performance in estimating forces applied to the forceps.

A more common way to measure forces (in medical devices and elsewhere) is based on strain measurement using strain gauges [9, 10]. This is known as a resistive-based sensing approach widely applied in industry. In general, the gauge is bonded to a flexible structure so that when a force is applied to the tool structure, the electrical resistance of the strain gauge will change, resulting in a change of the amplitude of the electrical signal used to evaluate the magnitude of the applied force. However, there is trade-off between the stiffness of the structure and the sensitivity of the measurement since the stiffer the structure of the tool is, the lower is the sensitivity in the force measurement that can be obtained [11].

In case that better sensitivity is essential, capacitive-based sensing methods represent an alternative since such methods are much more sensitive than the strain gauge sensing approach. By exploiting this specific advantage of the capacitive-based sensing technique, Gray and Fearing successfully developed an eight-by-eight capacitive sensor array which has a size of less than  $1 \text{ mm}^2$  [12]. Because of its small size and high resolution in detecting force signals, and its adequate distribution over all cells of the array, this sensor is particularly attractive for the integration in miniaturised MIS devices including miniaturised surgical manipulators and catheters.

The use of piezoelectric materials has led to another sensing technique known as piezoelectric-based sensing. If it is well fabricated, a piezoelectric material can produce voltage signals that are proportional to the deformation of the sensing structure. Even a small compression can generate a large output voltage, clearly indicating the sensitivity of this approach. A popular piezoelectric material used for developing tactile sensors is polyvinylidene fluoride (PVDF). For an application in MIS, Sokhanvar *et al.* employed PVDF to create a grasper that can be used to measure force, its distribution and the softness of the tissue being grasped simultaneously [13]. Due to the simple but effective sensing structure of the employed PVDF film, the prototype design shows a great possibility in miniaturising all of its sensing components to the required scale of MIS.

A further approach to measuring forces that has recently found increased attention is a sensing scheme that is based on optical principles. The main components of such a force sensor are a light source, a modulator and an optical detector. Light is initially generated by the light source and is transmitted to the modulator. This light is then modulated in proportion to the measured force before it is detected by the optical detector. When the modulated light signal is detected at the detector, it is converted into an electrical signal and processed by electronic circuitry for noise filtering, signal amplification and digitisation. Figures 10.1 and 10.2 illustrate recently developed optical-based force sensing devices designed for evaluating mechanical tissue property (e.g., tissue stiffness) during MIS [14, 15]. The device shown in Figure 10.1 consists of a light emitting diode (LED) which is used as a light source, a photodiode mounted on the opposite side of the tool's shaft and a sphere located at the distal end of the shaft [14].

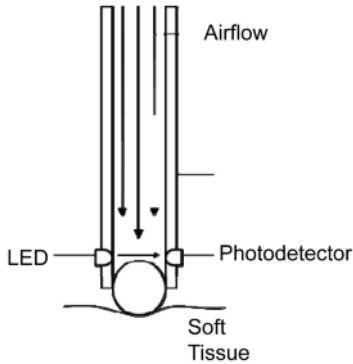

**Fig. 10.1** An optical-based force sensor designed for evaluating mechanical tissue properties during MIS

In use, the sphere is forced slightly out of the shaft by a continuous airflow and pressed against the soft tissue under investigation. Supported by the aircushion, the sphere can be rolled over the surface of the soft tissue in a virtually frictionless manner enabling relatively large tissue regions to be examined rapidly. During this rolling examination, the tissue is indented by the sphere causing the tissue's counteracting reaction force to displace the sphere slightly along the longitudinal shaft axis. This, in turn, partially interrupts the light projected from the LED to the photodiode. The intensity of the light signal is then modulated in proportion of the tissue interaction force. In this sensing system, the force applied onto the tissue can be varied over a wide range by altering the flow rate of the air passing through the shaft<sup>2</sup>. The output readings from the photodiode are amplified and transferred to a data acquisition system for further processing and analysis.

To overcome the miniaturisation problem in MIS, many optical-based force sensors make use of optical fibres to transmit light over large distances. This approach has the advantage that relatively bulky elements of the overall sensor system (such as light source and photo-detector) can be situated remotely, while the optics near the sensing region where the actual light signal modulation takes place can be miniaturised without too many difficulties. In such systems, the modulator usually contains a reflector which is attached to a flexible part. When a force causes the flexible structure of the sensor system to deform, the reflector position will be changed, causing the light signal used to evaluate the magnitude of the force to be modulated.

<sup>2</sup> Note that carbon dioxide gas which is usually used to insufflate the abdominal cavity during laparoscopic surgery can be used instead of air to generate the required aircushion.



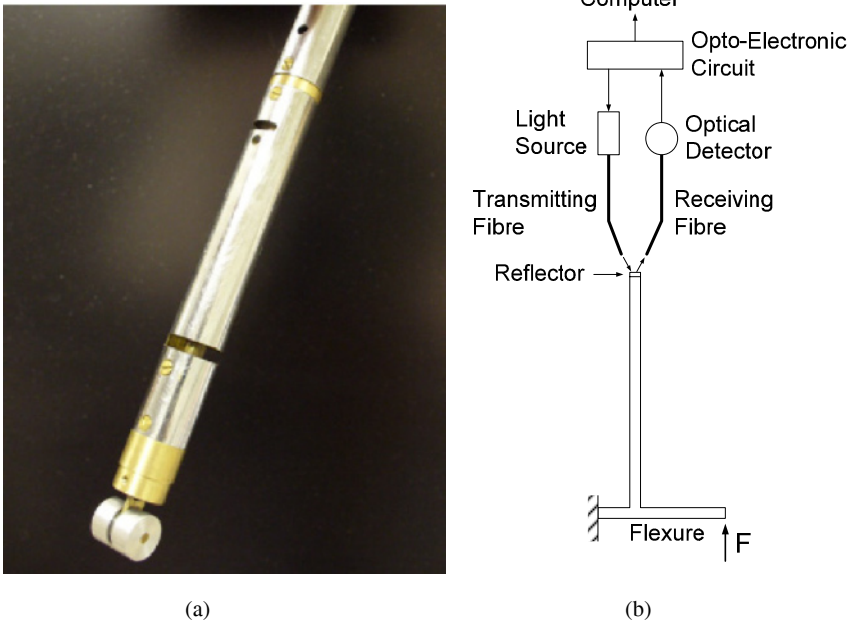

**Fig. 10.2** An optical fibre sensor designed to perform tissue stiffness investigation during MIS; (a) the sensor prototype which is equipped with a distal wheel for rolling over investigated tissue and (b) a schematic diagram of the sensor

Figure 10.2 (a) illustrates an optical fibre sensor which is designed to perform tissue stiffness investigation during MIS [15, 16]. The sensor operates based on a transmission-receive principle involving two optic fibres; one optical fibre transmits light to a reflector which in turn reflects light to the receiving fibre, as shown in the schematic diagram of Figure 10.2 (b). The reflector is located on a flexible structure or flexure. When a force is applied to the flexure, its structure will be deformed and the reflector will shift aside, causing the intensity of the light received at the receiving fibre to be modulated. This modulated light intensity can then be detected by using an optical detector and a force estimate can be obtained.

An important benefit of optical fibre sensors is that they can be used in conjunction with Magnetic Resonance Imaging (MRI). MRI is one of the numerous medical imaging techniques that offer a number of benefits including detailed soft tissue images with high contrast between different types of tissues. Due to its outstanding capability in providing soft tissue contrast images, it is frequently used in oncological, musculoskeletal, neurological and cardiovascular imaging. However, because MRI is based on the process of using strong magnetic and radiofrequency fields, sensors which operate based on electrical signals cannot be used in the MR-environment. Optical-based sensing systems using optical fibres remain one of the few methods that can be applied in MRI devices or MRI-guided robotic systems [17].

## 10.3 The Use of Force Sensing in Medical Robotics

### 10.3.1 Haptic Feedback During Robotic Surgery

The use of force sensing in medical robotics, and especially in soft tissue surgery, is an emerging research field and has been drawing increased attention worldwide. One of the applications of force sensing is to provide haptic feedback during robotic MIS. Haptic feedback represents both cutaneous (tactile) and kinesthetic (force) information, both of which are required to mimic the sensation felt by a human hand [18]. During open surgery and to a certain extent during standard laparoscopic surgery, the surgeon has the ability to gain haptic feedback from the surgical environment and use this information to make diagnostic, therapeutic and interventional decisions

Currently, the most established medical robot is the da Vinci<sup>®</sup> Surgical System from Intuitive Surgical. This provides surgeons with 7-degrees of freedom of *in vivo* dexterity via a teleoperated master-slave configuration. However, while this teleoperated control architecture is ideal for controlling miniature end effectors, it also decouples the surgeon from the surgical site. During any procedure performed with a robot aided surgery system such as the da Vinci Robot, all aspects of haptic feedback are completely absent. In fact, surgeons use the enhanced 3D vision provided by a stereo laparoscope to infer the interaction forces applied to the tissue to compensate for the loss of their sense of touch.

While haptic feedback during robotic surgery is still in its infancy, it has experienced a rapid advance over recent years. Examples include a miniature 6-axis force/torque sensor incorporated into an MIS forceps [19], sensory substitution to provide a visual indication of excessive force without rendering forces to the master console [20] and evaluating sensor/actuator asymmetries by only implementing haptic feedback on specific axes and thus allowing analysis of which forces are critical to the operator and which may be discarded [21].

Key difficulties in incorporating haptic feedback into such a system are the unavailability of sensors capable of measuring forces along each of the seven degrees of freedom and sophisticated control problems in how to intuitively render these to the operator and at the same time maintain system stability. This problem is further compounded by the miniaturisation and sterilisation requirements of minimally invasive surgery. While no suitable force sensor currently exists in a commercial capacity, research is being performed in several areas in an attempt to better understand the problem and overcome existing device limitations [22–24, 28–42].

### ***10.3.2 Soft Tissue Diagnosis Through Tissue Mechanical Property Identification***

Besides providing haptic feedback during robotic surgery, another application of force sensing is for biomechanical soft tissue identification, which is an important tool for tissue diagnosis with real prospects of improving the outcome of the surgery.

There are measurable differences in the mechanical characteristics between benign and malignant tissue [22–24]. *In vitro* experiments were conducted to examine the relationship between the pathology and the mechanical properties of prostatic tissues, and to develop a technique for the diagnosis of benign prostatic hyperplasia (BPH) [22, 23]. Results showed that measurable differences exist between the mechanical characteristics of benign and malignant prostatic tissue and that there is a statistically significant reproducible difference in stiffness between prostatic tumour tissue and normal healthy tissue. Additionally, Brock *et al.* reported that the stiffness of cancerous liver tissue is as much as 10 times larger than healthy liver tissue, providing further evidence that significant correlations exist between tissue pathology and mechanical characteristics [24].

Hence, biomechanical soft tissue identification via force measurement can be used to aid surgeons in performing both diagnostic and therapeutic interventions, compensating for the loss of haptic sensing experienced during laparoscopic or robot-assisted minimally invasive surgery.

#### *Biomechanics of Soft Tissue*

Non-load-bearing biological soft tissues are well known for their highly non-linear characteristics and viscoelasticity. Many soft tissues are anisotropic, heterogeneous, and nearly incompressible. They have a porous internal structure and variable mechanics depending on the environment such as pH, temperature and health. Due to their viscoelastic nature, they show hysteresis, creep and stress relaxation. Their stress-strain relationship is incrementally non-linear with strain. They exhibit hysteresis loops in cyclic loading and unloading. Under repeated cycles, they show preconditioning which is a steady state where the stiffness and hysteresis stabilise in successive cycles. The biomechanics of soft tissue is time and strain rate dependent. They are difficult to be characterised due to their inherent complexity, the degradation of mechanical properties after death and poorly known boundary conditions [25, 26].

#### *The Modelling of Non-linear Strain-stress Function*

Hyperelastic theory is widely used for describing the non-linear strain-stress function of soft tissue. Hyperelastic material is defined as an elastic material which has a strain energy function. The function models the stress-strain relationship of non-linear elastic material, disregarding the deformation history,

heat dissipation and stress relaxation. Fung described the stress and strain relationship using a strain energy function [25]:

$$S_{ij} = \frac{\partial(\rho_0 w)}{\partial \sigma_{ij}} \quad (i, j = 1, 2, 3) \quad (10.1)$$

where  $S_{ij}$  is the stress vector,  $\sigma_{ij}$  is the strain vector,  $\rho_0$  is the density and  $w$  is the strain energy per unit volume.

The strain-energy function  $\sigma_0 w$  can be written in many forms. Fung defined the 2D strain-energy function as:

$$\rho_0 w = f(\alpha, \sigma) + c.e^{[F(b, \sigma)]} \quad (10.2)$$

where

$$f(\alpha, \sigma) = \alpha_1 \sigma_{11}^2 + \alpha_2 \sigma_{22}^2 + \alpha_3 \sigma_{12}^2 + \alpha_3 \sigma_{21}^2 + 2\alpha_4 \sigma_{11} \sigma_{22}$$

and

$$F(b, \sigma) = b_1 \sigma_{11}^2 + b_2 \sigma_{22}^2 + b_3 \sigma_{12}^2 + b_3 \sigma_{21}^2 + 2b_4 \sigma_{11} \sigma_{22}.$$

The variables,  $\sigma_{ij}$ ,  $b_k$  and  $c$  are constants,  $\sigma_{12}$  ( $\sigma_{21}$ ) are the shear strain which could be considered zero when subjected to a 1D compression or stretch, and  $\sigma_{ii}$  is the normal strain.

### *The Modelling of Linear Viscoelasticity*

Linear viscoelastic mechanical models are often used to describe the viscoelastic behaviour of biological tissues. The development of the mathematical theory of linear viscoelasticity is based on a “superposition principle” [27]. This implies that the strain at any time is directly proportional to the stress. The general differential equation for linear viscoelasticity is expressed as follows [27]:

$$\left( 1 + \alpha_1 \frac{\partial}{\partial t} + \alpha_2 \frac{\partial^2}{\partial^2 t} + \alpha_n \frac{\partial^n}{\partial^n t} \right) \sigma = \left( \beta_0 + \beta_1 \frac{\partial}{\partial t} + \beta_2 \frac{\partial^2}{\partial^2 t} + \beta_m \frac{\partial^m}{\partial^m t} \right) \gamma \quad (10.3)$$

where  $n = m$  or  $m - 1$ ,  $\gamma$  is strain,  $\sigma$  is stress and  $\alpha_i$  and  $\beta_i$  are constants.

In mechanical models, Hookean elasticity is represented by a spring and Newtonian viscosity is presented by a dashpot. The basic models include the Voigt (spring and dashpot in series), Maxwell (spring and dashpot in parallel), and Kelvin (spring in parallel with a Maxwell) models [25–27]. By adding more elements to basic models, more complicated models can be obtained. In rheological theory, Roscoe described that all models, irrespective of their complexity, can be reduced to two canonical forms as shown in Figure 10.3

(without spring  $k_1$ ) [27]. Subsequently, Fung added a spring to each of the canonical forms to correct these models for biological soft tissue (shown in Figure 10.3), namely, the generalised Kelvin body and generalised Maxwell body [25].

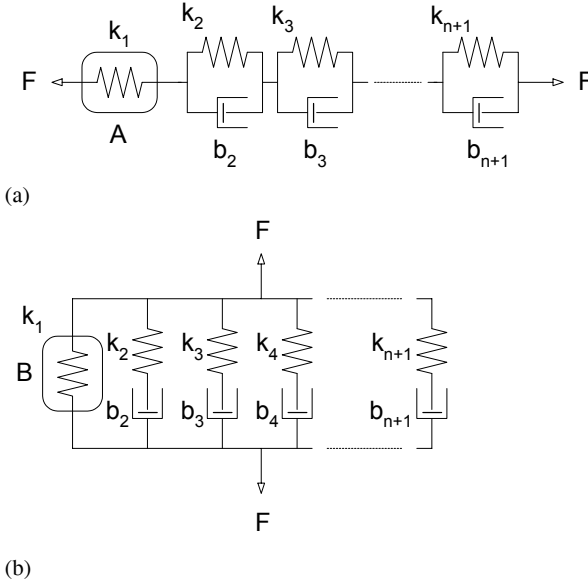

**Fig. 10.3** The generalised Maxwell body (a) and Kelvin body (b). The springs inside the blocks A and B are added by Fung. The models proposed by Roscoe are without these two springs

If  $d/dt$  is substituted by symbol  $D$ , then the differential equation of the generalised Kelvin body of order  $n + 1$  is [25]:

$$f_{n+1}(D)F = g_{n+1}(D)u \tag{10.4}$$

where

$$f_{n+1}(D) = f_n(D) \left( 1 + \frac{k_{n+1}}{b_{n+1}} D \right)$$

and

$$g_{n+1}(D) = g_n(D) \left( 1 + \frac{k_{n+1}}{b_{n+1}} D \right) + k_{n+1} f_n(D) D.$$

The generalised Maxwell Model of order  $n + 1$  is expressed as:

$$F = k_1 u + \sum_{i=2}^{n+1} \frac{D}{D/k_i + 1/b_i} u \tag{10.5}$$

where  $F$  is the force,  $u$  is the deformation and  $k_i$  and  $b_i$  are the elasticity and viscosity respectively.

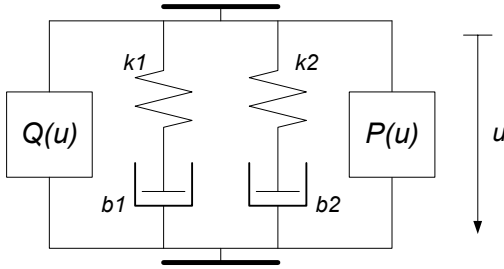

**Fig. 10.4** Dual Maxwell model with non-linear stress-strain functions

*The Modelling of Non-linear Viscoelasticity*

Recent research [28, 29] has shown that by adding non-linear functions into a linear dual Maxwell model, the non-linear viscoelastic characteristics of tissue samples can be simulated accurately and comprehensively, as long as the modelling parameters are properly calibrated.

The proposed model is as shown in Figure 10.4; two non-linear functions ( $P(u)$ ,  $Q(u)$ ), are added to each linear Maxwell model to cope with large deformations. Variable  $u$  is the tissue deflection (unit in meter),  $k_i$ ,  $b_i$  ( $i = 1, 2$ ) are the elastic modulus and material coefficient of viscosity respectively. Terms  $P(u)$  and  $Q(u)$  are third order polynomials of tissue deflection  $u$ .

The differential equation of the non-linear Dual Maxwell model has been deduced from Equation 10.5 and is expressed as:

$$f + \left( \frac{b_1}{k_1} + \frac{b_2}{k_2} \right) \dot{f} + \frac{b_1 b_2}{k_1 k_2} f = [P(u)b_1 + Q(u)b_2] \dot{u} + \left[ P(u) \frac{b_1 b_2}{k_2} + Q(u) \frac{b_1 b_2}{k_1} \right] u . \tag{10.6}$$

Under constant deformation  $u$ , the stress relaxation of the non-linear viscoelastic model is expressed as:

$$f = P(u)k_1 \cdot y \cdot e^{-\frac{k_1}{b_1}t} + Q(u)k_2 \cdot y \cdot e^{-\frac{k_2}{b_2}t} . \tag{10.7}$$

Under linear deformation ( $u = Ht$ ), the predicted tissue response is given as:

$$f = P(Ht)k_1 \cdot H \frac{b_1}{k_1} \left( 1 - e^{-\frac{k_1}{b_1}t} \right) + Q(Ht)k_2 \cdot H \frac{b_2}{k_2} \left( 1 - e^{-\frac{k_2}{b_2}t} \right) . \tag{10.8}$$

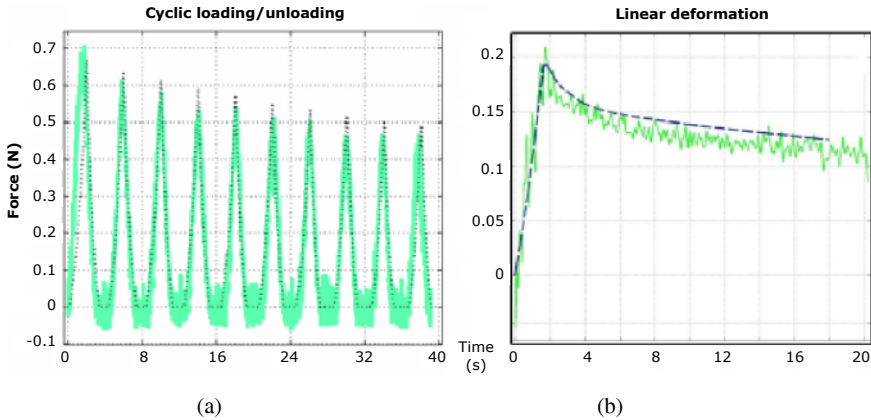

**Fig. 10.5** The comparison of the modelling results (*dashed line*) and experimental data for the cyclic loading/unloading condition (a) and linear deformation condition (b)

The developed model has been evaluated both statically and dynamically with different strain rates and cyclic loading/unloading conditions (Figure 10.5). By comparing simulation results and measured experimental data, it has been concluded that the proposed model is robust for modelling both static and dynamic indentation conditions [29].

#### *Soft Tissue Diagnosis Through Tissue-instrument Interaction*

Traditionally, the mechanical properties of soft tissues have been studied via force measurement from uniaxial tissue-tool interaction. A number of empirical formulae have been developed to predict the stress-strain characteristics of soft tissue indentation and to estimate the forces during soft tissue penetration [30–34].

More complex finite-element (FE) analyses have also been carried out to simulate 1D soft tissue deformation [35–39]. While these approaches are effective in a localised setting, they are incapable of providing a comprehensive overview of mechanical properties of tissue samples due to the tissue's heterogeneous and anisotropic nature [40].

In order to effectively diagnose tissue properties during robotic MIS or, more importantly, to indicate the presence of an underlying abnormality, a large area of an organ must be examined under reasonably constant conditions. One subset of research which aims to achieve a better insight into the mechanical properties of soft tissue organs despite their inhomogeneity is that of “Mechanical Imaging”. This is a new technology of medical diagnostics in which internal structures of soft tissue are visualised by sensing the mechanical stresses on the surface of an organ using tactile sensor arrays [40]. In contrast to other existing imaging modalities which use sophisticated hardware such as MRI or CT, current mechanical imaging devices only require a tactile sensor array and a positioning system. There are currently two applications of such a device being developed for the diagnoses

of breast [41] and prostate cancer [42]. In both of these cases, palpation has proven to be an effective method for detecting and monitoring pathological changes.

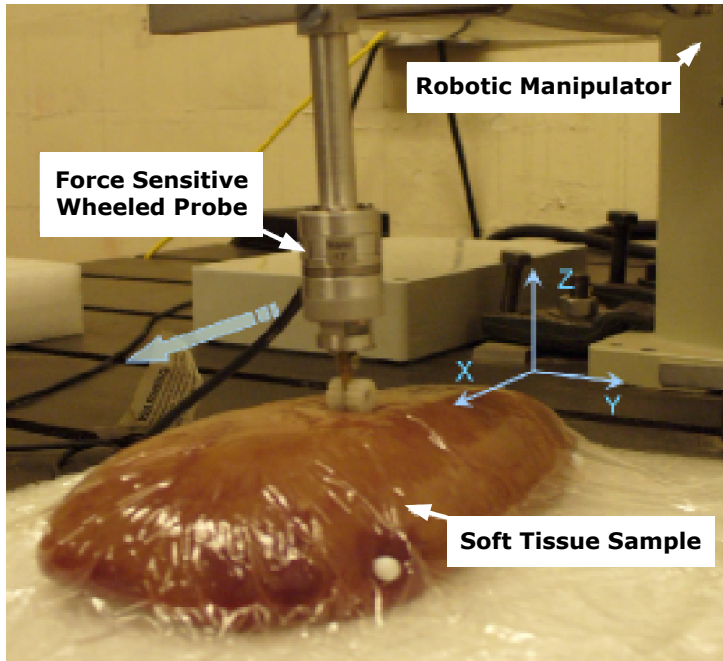

**Fig. 10.6** Wheeled force-sensitive probe in *ex vivo* liver experiments. The probe is attached to a robotic manipulator and rolled over the tissue. The indentation depth is kept constant during the experiment

While the results from both cases illustrate that tactile sensor arrays have potential as diagnostic tools, their adaptation to MIS is difficult due to the problems associated with miniaturisation and sterilisation.

Recent experimental studies show that the sensitivity of irregularity detection within a soft tissue can be increased by performing rolling indentation across the surface of a tissue sample using a wheeled force-sensitive probe (Figure 10.6) [28]. Moreover, by using multiple rolling paths to cover a large area, the inhomogeneity of the mechanical properties of the selected area can be mapped in form of a mechanical image [16]. This image can be used to either visualise the internal structure of the soft tissue and thus to identify abnormal tissue regions (Figure 10.7) or characterise the mechanical soft tissue properties in terms of their geometrical stiffness distribution (Figure 10.8) and force-tissue deflection characteristics.



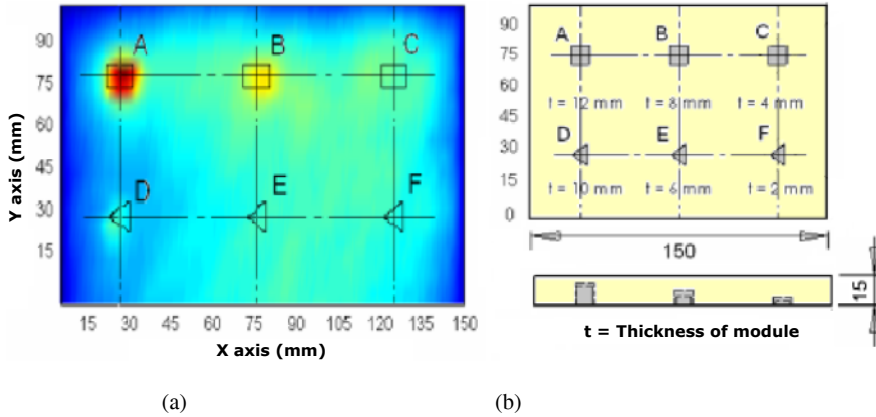

Fig. 10.7 Mechanical image (a) from rolling indentation on a silicone phantom (b)

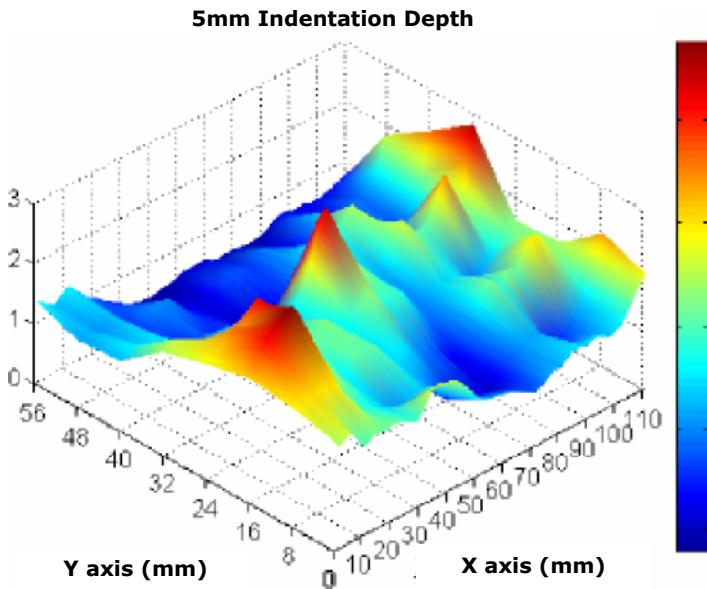

Fig. 10.8 The geometry of the stiffness distribution of a liver sample; the indentation depth during this rolling experiment was kept at a constant value of 5 mm. The units on the colour bar are in Newtons

Compared to uniaxial tissue-tool interaction, the primary advantage of the rolling indentation is that instead of performing a series of discrete measurements, the probe allows for the continuous measurement of the underlying mechanical response of the tissue as it rolls over the surface of an organ. This allows for rapid coverage of a surface and enhanced sensitivity to tissue irregularities. As only a force-sensitive probe and positioning system are required, the adaptation of the wheel-rolling indentation into robotic MIS is promising.

## References

1. Nof SY (1999) Handbook of Industrial Robotics, John Wiley and Sons
2. Davis B (2000) A Review of Robotics in Surgery, Proc Instn Mech Engrs, Part H, 214:129–140
3. Shoham M, Burman M, Zehavi E, Joskowicz L, Batkilin E, Kunicher Y (2003) Bone-Mounted Miniature Robot for Surgical Procedures: Concept and Clinical Applications, IEEE Trans. on Robotics and Automation, 19(5):893–901
4. Puangmali P, Althoefer A, Seneviratne LD, Murphy D, Dasgupta P (2008) State-of-the-Art in Force and Tactile Sensing for Minimally Invasive Surgery, IEEE Sensors Journal, 8(4):371–381
5. Rosen J, Hannaford B, MacFarlane MP, Sinanan MN (1999) Force Controlled and Teleoperated Endoscopic Grasper for Minimally Invasive Surgery – Experimental Performance Evaluation, IEEE Trans. Biomed. Eng., 46(10): 1212–1221
6. Klafter RD, Chmielewski TA, Negin M (1989) Robotic Engineering: An Integrated Approach, Englewood Cliffs, Prentice Hall, NJ
7. Tholey G, Pillarisetti A, Green W, Desai JP (2004) Design, Development, and Testing of an Automated Laparoscopic Grasper with 3-D Force Measurement Capability, Int. Symp. Medical Simulation, 3:8–48
8. Tadano K, Kawashima K (2006) Development of 4-DOFs Forceps with Force Sensing Using Pneumatic Servo System, IEEE Int. Conf. Robot. Autom., 2250–2255
9. Dario P, Hannaford B, Menciassi A (2003) Smart Surgical Tools and Augmenting Devices, IEEE Trans. Robot. Autom., 19(5):782–792
10. Tavakoli M, Aziminejad R, Patel RV, Moallem M (2006) Methods and Mechanisms for Contact Feedback in a Robot-Assisted Minimally Invasive Environment, Surg. Endosc., 20:1570–1579
11. Craig J (2003), Introduction to Robotics: Mechanics and Control, Prentice Hall, Harlow
12. Gray BL, Fearing RS (1996) A Surface Micromachined Microtactile Sensor Array, IEEE Int. Conf. Robot. Autom., 1–6
13. Sokhanvar S, Packirisamy M, Dargahi J (2007) A Multifunctional PVDF-Based Tactile Sensor for Minimally Invasive Surgery, Smart Mater. Struct., 16:989–998
14. Zbyszewski D, Liu H, Puangmali P, Althoefer K, Nunes CS, Seneviratne LD, Challacombe B, Murphy D, Dasgupta P (2008) Wheel/Tissue Force Interaction: A New Concept for Soft Tissue Diagnosis during MIS, submitted to IEEE Eng. Medicine Biol. Soc. Int. Conf.
15. Puangmali P, Liu H, Althoefer K, Seneviratne LD (2008) Optical Fiber Sensor for Soft Tissue Investigation during Minimally Invasive Surgery, IEEE Int. Conf. Robot. Autom., 2934–2939
16. Liu H, Noonan DP, Althoefer K, Seneviratne LD (2008) The Rolling Approach for Soft Tissue Modeling and Mechanical Imaging during Robot-Assisted Minimally Invasive Surgery, IEEE Int. Conf. Robot. Autom., 845–850
17. Tada M, Sasaki S, Ogasawara T (2002) Development of an Optical 2-Axis Force Sensor Usable in MRI Environments, Proc. IEEE Sensors, 2:984–989
18. Okamura AM (2004) Methods for Haptic Feedback in Teleoperated Robot-Assisted Surgery. Industrial Robot, An International Journal, 31(6):499–508
19. Seibold U, Hirzinger G (2003) A 6-axis Force/torque Sensor Design for Haptic Feedback in Minimally Invasive Robotic Surgery, 2<sup>nd</sup> VDE World Microtechnologies Congress
20. Kitagawa M, Dokko D, Okamura AM, Bethea BT, Yuh DD (2004) Effect of Sensory Substitution on Suture Manipulation Forces for Surgical Teleoperation, Medicine Meets Virtual Reality, 157–163
21. Verner LN, Okamura AM (2006) Sensor/Actuator Asymmetries in Telem manipulators: Implications of Partial Force Feedback, 14th International Symposium on Haptic Interfaces for Virtual Environments and Teleoperator Systems, 309–314

22. Phipps S, Yang THJ, Habib FK, Reuben RL, McNeill SA (2005) Measurement of Tissue – Mechanical Characteristics to Distinguish between Benign and Malignant Prostatic Disease, *Urology*, 66: 447–450
23. Yang TH, Leung SK, Phipps S, Reuben RL, McNeill SA, Habib FK, Schnieder A, Stevens R (2006) In-vitro Dynamic Micro-Probing and the Mechanical Properties of Human Prostate Tissues, *Technology and Health Care*, 14: 281–296
24. Brock KK, Dawson LA, Sharpe MB, Moseley DJ, Jaffray DA (2006) Feasibility of a Novel Deformable Image Registration Technique to Facilitate Classification, Targeting and Monitoring of Tumor and Normal Tissue, *Int. Journal of Radiology, Oncology, Biology, Physics*, 64(4): 1245–1254
25. Fung YC (1993) *Biomechanics: Mechanical Properties of Living Tissues*, Springer-Verlag, New York
26. Humphrey JD (2002) *Continuum Biomechanics of Soft Biological Tissues*, *Proc. R. Soc. Lond. A*, 1–43
27. Barnes HA, Hutton JF, Walters K (1989) *An Introduction to Rheology*, Elsevier Science, BV
28. Noonan DP, Liu H, Zweiri YH, Althoefer K, Seneviratne LD (2007) A Dual-Function Wheeled Probe for Tissue Viscoelastic Property Identification during Minimally Invasive Surgery, *IEEE Int. Conf. Robot. Autom.*, 2629–2634
29. Liu H, Noonan DP, Zweiri YH, Althoefer K, Seneviratne LD (2007) The Development of Nonlinear Viscoelastic Model for the Application of Soft Tissue Identification, *IEEE/RSJ Int. Conf. Intelligent Robots and Systems*, 208–213
30. Okamura AM, Simone C, O’Leary MD (2004) Force Modelling for Needle Insertion into Soft Tissue, *IEEE Trans. Biomed. Eng.*, 51(10): 1707–1716
31. Carter FJ, Cuschieri A, Mclean D, Davies PJ, Frank TG (2001) Measurements and Modeling of the Compliance of Human and Porcine Organs, *Med Image Anal*, 5(4): 231–236
32. Ottensmeyer MP (2002) In-vivo Measurement of Solid Organ Viscoelastic Properties, *Medicine Meets Virtual Reality 02/10*, *Stud Health Techno Inform*, 85:328–333
33. Brown JD, Rosen J, Kim YS, Chang L, Sinanan MN, Hannaford B (2003) In-vivo and In-situ Compressive Properties of Porcine Abdominal Soft Tissues, *Studies in Health Technology and Informatics – Medicine Meets Virtual Reality*, 94:26–32
34. Brouwer I, Ustin J, Bentley L, Sherman A, Dhruv N, Tendick F (2001) Measuring in-vivo Animal Soft Tissue Properties for Haptic Modelling in Surgical Simulation, *Studies in Health Technologies and Informatics*, 81 :69–74
35. Tonuk E, Barbara S (2003) Nonlinear Elastic Material Property Estimation of Lower Extremity Residual Limb Tissues, *IEEE Trans. Neural Syst. Rehabil. Eng.*, 11:43–53
36. Yongmin Z, Bijan S, Gursel A, Julian S (2005) A New Methodology for Deformable Object Simulation, *IEEE Int. Robot. Autom.*, 1914–1919
37. Szekely G, Brechbuhler Ch, Hutter R, Rhomberg A, Ironmonger N, Schmid P (2000) Modelling of Soft Tissue Deformation for Laparoscopic Surgery Simulation, *Medical Image Analysis*, 4:57–66
38. Schwartz J, Denninger M, Rancourt D, Moisan C, Laurendeau D (2005) Modelling Liver Tissue Properties using a Non-Linear Viscoelastic Model for Surgery Simulation, *Medical Image Analysis*, 9:103–112
39. Alpaslan D, Jian JZ, Hankovan V (2003) Efficient Modeling and Simulation of Soft Tissue Deformation Using Mass-Spring Systems, *Int. Congress Series*, 1256:337–342
40. Sarvazyan A (1998) Mechanical Imaging: A New Technology for Medical Diagnostics, *Int. J. Med. Informat.* 49:195–216
41. Wellman SP, Dalton EP, Krag D, Kern KA, Howe RD (2001) Tactile Imaging of Breast Masses: First Clinical Report, *Arch Surg*.136:204–208
42. Egorov V, Ayrapetyan S, Sarvazyan AP (2006) Prostate Mechanical Imaging: 3-D Image Composition and Feature Calculations, *IEEE Trans. Med. Imag.*, 25(10):1329–1340

# **Chapter 11**

## **Intelligent Prosthesis – a Biomechatronics Approach**

**Abbas Dehghani<sup>1</sup>**

### **11.1 Introduction**

Systems are becoming more and more complex and there is an ever increasing need to address all relevant issues beginning with the initial conceptual design stage. If a complex system having precision mechanical components, electronic circuitry and control software is considered in detail, it is appreciated that there is a close relation and interaction between these elements in the system. Consider a complex mechatronic system having all of the aspects referred to above and which is going to be used in association with a complex biological system. In this case, there needs to be a close relationship with and interaction between the biological system and the mechatronic system, requiring that a biomechatronic approach is adopted in its design and development. Such an approach could also be used in other instances such as the design and development of complex mobile robots<sup>2</sup>. The human body combines intelligence with sophisticated sensors and actuators, making it the most logical source of inspiration and study when designing and developing many intelligent systems.

In this chapter, an overview will be given of biomechatronics and the approach to the design and development of intelligent systems. As the case study is that of lower limb prosthetics, a brief description is given of human lower limb functions. Prosthetics are then reviewed and analysed as an example of a biomechatronic system.

---

<sup>1</sup> University of Leeds, UK

<sup>2</sup> See Chapter 9.

## 11.2 Biomechatronics and Biological Systems

Nature has always been a source of inspiration for technological development [1]. However, due to limitations in science and engineering, only relatively elementary successes could at first be achieved. In recent decades, advances in micro and nano technologies and a better understanding of biological systems have opened up new and exciting windows into the design and development of systems which mimic their biological counterparts. The term bionics was coined by Jack E. Steele in 1958 [2] and it is defined as:

The application of biological methods and systems found in nature to the study and design of engineering systems and modern technology... and the study of systems which function after the manner of or in a manner characteristic of or resembling living systems [2, 3].

Other terms have also been used in recent years such as biomimetics or biomimicry which refer to a branch of science

...that studies nature, its models, systems, processes and elements and then imitates or takes creative inspiration from them to solve human problems by modelling on or in some way resembling a natural biological structure, material, or process [4, 5].

The introduction of these terms and the use of biological systems as models for the design and engineering of complex systems demonstrate that scientists and engineers are paying attention to and learning from biological solutions.

### 11.2.1 Biomechatronics

Biomechatronics refers to a subset of mechatronics where aspects of the disciplines of biology, mechanics, electronics and computing are involved in the design and engineering of complex systems to mimic biological systems. It is defined as:

An applied interdisciplinary science that aims to integrate mechanical elements in the human body, both for therapeutic uses (e.g., artificial hearts) and for the augmentation of existing abilities [6].

In illustration, consider the following:

- an intelligent prosthetic hand or leg with functionality similar to a biological hand and leg;
- an artificial eye to help blind people to see;
- an artificial hearing device to help deaf people to hear.

For each of these to become possible, advances are required in sensors, actuators and intelligent control, and even more importantly, in the interface between these systems and the brain and nervous system.

### ***11.2.2 The Human Body***

The human body consists of about 100 trillion cells. Each of the body's organs has a specific function and the interest herein is particularly focused on the musculoskeletal and nervous systems [7]. In the human organism, all motions are due to only one type of action, the contraction of muscles<sup>3</sup>. Consider the bending of the arm. This is achieved by use of the biceps and triceps muscles [8] to move the elbow in flexion (motion that reduces the angle between two parts) and extension (the opposite of flexion) respectively.

Meanwhile, the nervous system collects and analyses information about the environment and internal body functions, and is responsible for the control and coordination of those functions. The aspects of the nervous system which are of interest in here include the central nervous system<sup>4</sup> and the peripheral nervous system, including the nerves outside the brain and the spinal cord [9].

A human brain consists of about  $10^{11}$  highly interconnected neurons, forming a fast parallel processing network. Information processing in humans is thus based on a large number of simple processors. The sensory system is of great complexity in its own right. Thus, the skin, amongst its other functions, forms a complex distributed sensing surface for the sensing of force, temperature and humidity.

In the human body, a complex system consisting of intelligent control, highly distributed sensors and actuators can thus be observed. Examination of this and other similar systems is believed to help in the design and development of biomechatronic systems with particular reference to those which have direct interaction with the biological system.

## **11.3 Prosthetics**

Although prosthetics may be used to refer to artificial body parts, it primarily defines that branch of surgery dealing with the making and fitting of such artificial body parts [10]. Here, the emphasis will be on lower limb prosthetics.

The main purpose of lower limb prostheses is to provide the amputee with an artificial limb in order for them to be able to perform functional tasks and, in particular, ambulation or walking and may be used for any or all parts of the lower extremity (leg). Different levels of lower limb amputation include partial foot, ankle disarticulation (through ankle amputation), below the knee (transtibial), knee disarticulation, above the knee (transfemoral) and hip disarticulation.

---

<sup>3</sup> The musculoskeletal or locomotor system consists of bones, joints and muscles, and is associated with movement. Bones are attached to each other by joints and skeletal muscles to bones by tendons.

<sup>4</sup> The brain and spinal cord

Referring to the foot-ankle assembly, this should provide a base of support during standing and walking. Further functions needed for walking on even and uneven terrains include, for example, shock absorption and push off.

The shank then refers to the anatomical lower leg between the foot and the knee. The ankle-foot assembly is connected to the socket using the shank, which can be endoskeletal (with inside shank) or exoskeletal. The socket is the interface between the artificial limb and the residual limb, and distributes pressure around it. Suspension devices are used to keep the prosthesis firmly in place and make them comfortable for different functions.

For transfemoral amputees, the prosthesis should include a prosthetic knee, something which is itself a complex unit and is expected to support, as much as is possible, the functions of a biological knee to allow bending and straightening, and to provide stability during load bearing. Prosthetic knees are generally available as single-axis, polycentric, weight-activated, manual-locking, hydraulic and pneumatic units [11].

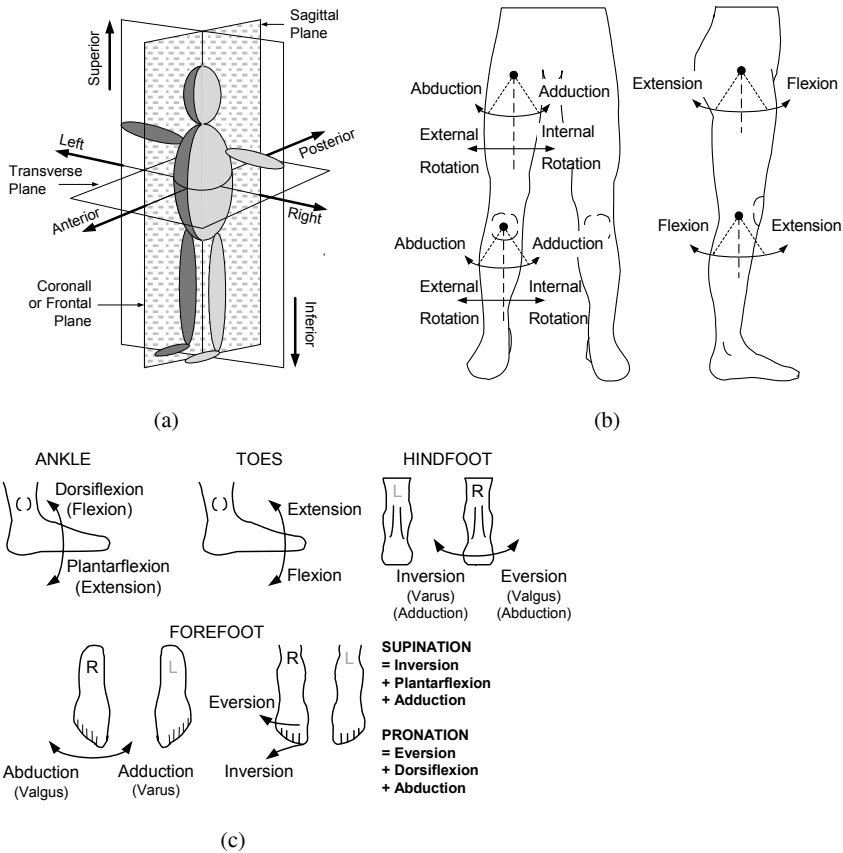

**Fig. 11.1** The human body [11] (a) anatomical positions, (b) movements of hip and knee, and (c) ankle, toe and foot

### 11.3.1 Human Locomotion

One of the most important functions of the lower limb prostheses is to provide the amputee, as much as is possible, with the ability for normal locomotion. In discussion of the motion of the leg, there are a number of commonly used terms and references and these are illustrated in Figure 11.1 [13].

#### Human Locomotion Analysis

Gait or walking is defined as:

A coordinated action of the neuromuscular and musculoskeletal systems. The coordination of muscle contraction, joint movement, and sensory perception allow the human body to move in the environment [12].

In terms of a biomechatronic system, it may be considered as four coordinated actions:

- calculation and analysis of some data by the central processing unit;
- preparation of the required signals to be sent to the actuation mechanism;
- actuation;
- sensing and preparation of signals to be fed back to the central processing unit.

In analysing human locomotion, the gait cycle is divided into two main periods: stance and swing. Stance refers to the period when the foot is in contact with the ground (~ 60% of the cycle) and the swing is then the time when the foot is in the air (~ 40% of the cycle). The gait cycle can also be considered in terms of functional tasks including weight acceptance, single-limb support and limb advancement or described in terms of phases as Initial Contact (IC), Loading Response (LR), Mid Stance (MSt), Terminal Stance (TSt), Pre Swing (PSw), Initial Swing (ISw), Mid Swing (MSw) and Terminal Swing (TSw). Figures 11.2 and 11.3 show the details of these. The loading response of the body during normal walking is then illustrated in Figure 11.4 which shows the force variations during stance period from initial contact (IC) to when the toe is off the ground (TO) [14].

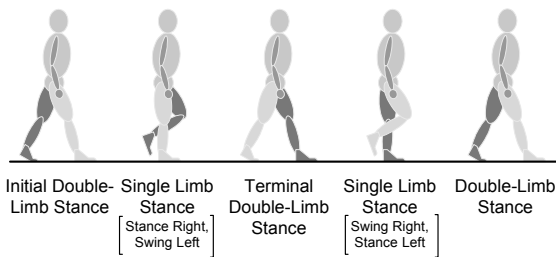

**Fig. 11.2** The gait cycle in normal human locomotion [15]



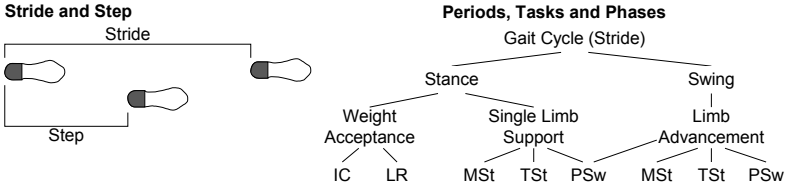

Fig. 11.3 Functional tasks and phases in normal human locomotion [15]

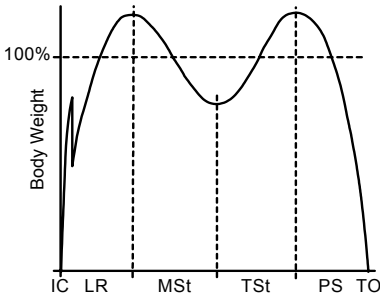

Fig. 11.4 The load response of the body during the stance period [15]

Walking is considered as the translation of the centre of mass through space in a way that requires the least energy expenditure. Six determinants or variables that affect this energy expenditure and hence the mechanical efficiency of walking have been identified. These are variations in pelvic rotation, pelvic tilt, knee flexion at mid stance, foot and ankle motion, knee motion and lateral pelvic displacement [15, 16]. Other issues to be considered include motion or kinematics, forces that create the motion, i.e., kinetics, ground reaction and muscle activities.

Kinematics deals with movement without taking into consideration the forces and torques which cause the motion. In human locomotion, linear and angular displacements, velocities, accelerations and decelerations are analysed. Systems are available to capture and analyse the motion of an individual’s lower and upper extremities, pelvis, trunk, and head during ambulation.

Kinetics is the study of forces that cause movements. In human walking, these are divided into two categories; internal forces which include muscle activity, ligamentous constraint, friction in muscles and joints and external forces including the ground reaction forces. These latter comprise the three components of vertical force, fore-aft shear and medial lateral shear. Joint movement is usually calculated around a joint centre. Therefore, a net knee extensor moment suggests that the knee extensor muscles are dominant and generate higher moments than the knee flexors. The joint angular velocity can also be measured and the product of joint moment and joint angular velocity will give a measure of power at the joint.

Electromyography (EMG) is used to measure muscle activity. There are two methods available: the non-invasive form using surface electrodes to collect muscle signals and the invasive form where fine wire electrodes (about 50 micron)

which are inserted into the muscle to precisely monitor activity. Figure 11.5 then illustrates the vertical reaction force during slow walking, normal walking and running in the five phases of the stance limb [15–20].

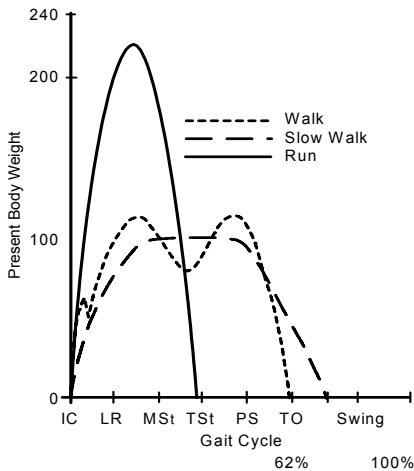

**Fig. 11.5** Vertical reaction force during slow walking, normal walking and running [16]

### *Impaired Locomotion*

Accurate and comprehensive analysis of normal human locomotion provides a model against which abnormal or impaired locomotion can be compared. This helps in understanding and diagnosing specific gait problems in amputees and hence not only how to help the patient, but to feedback into the design and development of more effective prostheses [20, 21].

## **11.3.2 Current Prosthetics**

### *Materials*

Materials to be considered in prosthetics are the structural materials used for strength and durability as well as some functionality and those used to give prosthetics a lifelike natural body appearance (cosmesis).

Weight has always been an issue with prosthetic devices and weight reduction, strength and functionality are the goals of prosthetic fabrication. Metal is mainly used for rotating components where as aluminium is an alternative to the steel that is used conservatively for smaller components. Titanium is more expensive, though due to its biocompatibility, it is considered for some aspects of prosthetic devices.

The advent of thermoplastics and their use for structural components was considered to be a breakthrough in prosthetics fabrication. Polypropylene in rigid form is used for structural support and polyethylene, being more flexible, is used in the prosthetic interface with the residual limb to provide a more comfortable and adjustable socket. Copolymers which can be heated and reshaped after initial fabrication to accommodate, for example, the changes in the residual limb, are also of increasing importance.

The use of carbon fibre composite materials is central to current prosthetics. The advantages of composite materials include extremely strong and light weight, simpler and less expensive alternatives to steel, aluminium, titanium and magnesium, greater resistance to corrosion, greater flexibility, impact resistance and vibration damping. They are also extremely resilient and show superior performance in a wide range of temperatures. The advantages of such new materials are savings in a patient's energy expenditure and an improved and more comfortable fit. Clinical studies have confirmed many aspects of these improvements [21–23].

Traditional prostheses used to be fabricated mainly in order to restore motor function; however, today's prosthetics are more lifelike with freckles, veins and hairs. Some attempts have also been made to simulate the three dermal layers of skin. Standard cosmeses are made from silicon, PVC (Polyvinyl Chloride) and urethane. The expected characteristics of these materials include being lifelike, stain resistant, flexible, tear resistant, resistant to extreme temperature and sun damage, having no moisture absorption and no reactions with the patient's body.

By using technologies such as 3D high-resolution scanning and 3D printing, a replica artificial limb can be produced by reversal of the sound limb to very fine levels of detail. For example, even finger prints can be present in the case of a prosthetic hand. The methods used to attach cosmeses to the artificial limb include adhesive, suction and form fitting or a combination of these. Sleeve type products are also used which can be heated to shrink, fit and form the body part [24].

### *Sensors*

The two main sensory aspects of the human body relevant to locomotion are proprioceptors and mechanoreceptors. Proprioception may be considered as self sensing [25]. In medical terms, it refers to:

A sense or perception, usually at a subconscious level, of the movements and position of the body and especially its limbs independent of vision; this sense is gained primarily from input from sensory nerve terminals in muscles and tendons (muscle spindles) and the fibrous capsule of joints combined with input from the vestibular apparatus.

A vestibular apparatus provides some sensory input in relation to balance. In the limbs, proprioceptors are sensors that provide information about position of the limb in space. Mechanoreceptors are those [25]:

...that respond to mechanical pressure or distortion; ... e.g., touch receptors in the skin.

During locomotion, signals from the brain based on intent are sent to muscles to provide actuation. There must also be a feedback loop to the brain to provide information on limb position and from the environment such that a totally adaptive locomotion can be achieved. For example, walking gait and patterns are different for different terrains. In current prosthetic devices, sensors are used to provide feedback to an on-board microprocessor, and by use of relevant algorithms, to provide as much adaptive locomotion as possible. Typical sensors include:

- accelerometers;
- gyroscopes to measure angular orientations and angular velocity;
- load cells to measure force;
- angular displacement or bending sensors to measure joint angles during walking. These can also be used to measure angular velocity.

### *Actuators*

Human muscles have a number of interesting functionalities such as the generation, consumption and transmission of force as well as energy storage. Currently, there are no actuators which completely mimic human muscle functions. However, research towards new polymeric materials is ongoing. These relatively new materials could be used as artificial muscles that exhibit more muscle-like functionality.

Lower limb prosthetic devices currently on the market are mainly based on passive components. Attempts have been made to manufacture powered knee and ankle prostheses, and recent years have seen some of these devices becoming available. Actuators currently used in prostheses include:

- hydraulic actuators, mainly as a passive device for damping;
- pneumatic actuators, mainly as a passive device for damping;
- DC motors;
- hybrid actuators (e.g., hydraulic and pneumatic).

New generations of actuators are also being tested for prosthetic devices. Examples of such actuators include:

- magnetorheological actuators;
- series elastic actuators.

In magnetorheological actuators, a smart fluid referred to as magnetorheological fluid is used in which there are suspended microsize magnetic particles. By applying a varying magnetic field, the apparent viscosity of the fluid can be varied. This means that actuator force can be controlled by controlling the applied magnetic field [26].

A typical example of a series elastic actuator is shown in Figure 11.6. Such a configuration offers a number of advantages including greater shock tolerance,

lower reflected inertia, more accurate and stable force control and more importantly, for certain applications, the capacity for energy storage [27].

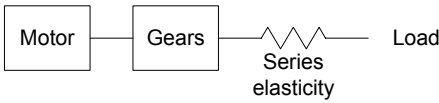

**Fig. 11.6** Series elastic actuator configuration

*Intelligent Control*

Normal human walking on different terrains requires adaptation of the locomotion system to the environment. In order to achieve this adaptation, an intelligent control system should continuously monitor the state of the relevant limbs, collect information from the environment and, after analysing the received information, provide the appropriate commands to ensure appropriate gait and stability.

Advances in microprocessors in terms of speed and the availability of memory coupled with developments in artificial intelligence have provided an opportunity for more intelligent prosthetic devices to be designed and manufactured. Recent prostheses are using such advances to provide end users with systems that can, to some extent, adapt to the user’s gait in different terrains.

*Transfemoral Prostheses*

Transfemoral prostheses are intended for above knee amputees and therefore include knee and ankle-foot components. As the knee is a complex part of the human locomotion system, above knee prostheses are themselves much more complex in terms of design and development when compared to the transtibial prostheses used by below- knee amputees. Typical current prostheses are shown in Figure 11.7.



**Fig. 11.7** Typical above knee prostheses (a) Smart adaptive knee (Blatchford) [28], (b) C-Leg (Otto Bock) [29], and (c) Rheo Knee (Ossur) [30]

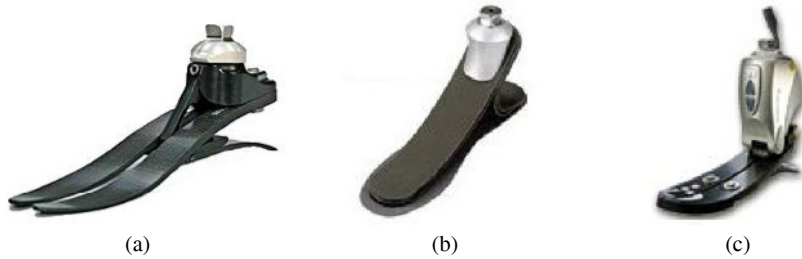

**Fig. 11.8** Typical below knee prostheses (a) Epirus (Blatchford) [28], (b) Carbon feet 1C30 (Otto Bock) [29], and (c) Proprio (Ossur) [30]

### *Transtibial Prostheses*

Transtibial prostheses are intended for below knee but above the foot amputees. These amputees are more likely to achieve normal locomotion as the knee is already intact. Typical below knee prostheses are shown in Figure 11.8.

### *Research and Development*

Current products are the result of many years of research and development. In this section, the principle idea is to follow through the research and development stages to appreciate how a biomechatronic approach could be adapted in the design and development of intelligent prosthetic devices in order to help amputees regain normal locomotion.

### *System Design and Development*

System development starts with a clear description of requirements which will then be translated into system specifications. For lower limb prosthetic devices, the ultimate aim is a system that mimics human locomotion including all aspects of functionality and appearance. Just considering the functionality, system requirements may be summarised in general terms as follows. The system should:

- provide normal locomotion;
- interact with the user;
- be comfortable;
- adapt to different terrains and environments;
- be energy efficient.

Translation of these requirements to engineering system specifications is not trivial. Research is needed to clearly understand normal human locomotion and how the biological system adapts itself to various terrains and environments. Such research into normal and pathological human locomotion [19, 20] has greatly helped the design and development of new generations of prosthetic devices. The testing and evaluation of these systems on amputees and the feedback from the

various parties involved have also helped in system development and refinement. Figure 11.9 illustrates the general steps involved in system design and development from initial stages to final validation and approval. It should be noted from the figure that all the stages of conceptual design, testing and validation of that as well as detailed design and prototyping involve a number of iterations before the final product satisfies the specifications and the requirements.

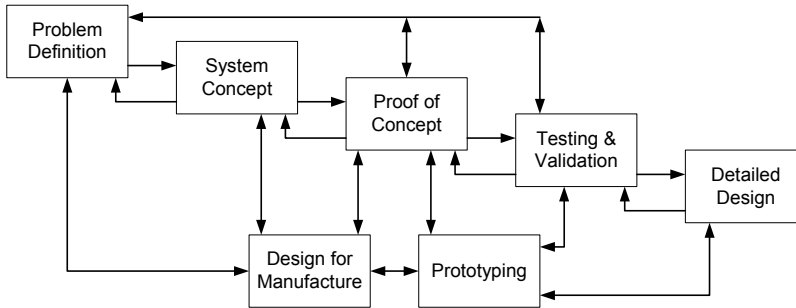

**Fig. 11.9** Steps involved in system design and development<sup>5</sup>

### *Specific Requirements*

Considering the phases of normal human locomotion described earlier, the requirements for an intelligent lower limb prosthesis based on the use of controlled damping devices can be detailed and expressed as a set of system design criteria for stance and swing control. These may be stated as [32, 33]:

- It should be able to provide stance phase support with a variation of resistances from free swing to high yield in order to complement the needs of different amputees under all conditions.
- It should have variable resistance during the swing phase to optimise heel rise for the entire walking speed range with an extension bias that is dependable whatever the walking speed.
- It should be possible to adapt the knee to the specifics of the individual user and thus be capable of a set of preprogrammable variables. These are stance control settings for walking, standing and ascending or descending ramps or stairs.
- It should have programmable resistance for stumble control to suit different levels of safety and security thus enabling users to recover from a stumble naturally.
- The swing phase control should be programmable for varying walking speeds, covering the entire walking speed range of an individual.

<sup>5</sup> The stages are shown separately here for simplicity. In practice, there would be a high degree of concurrency.

- Independently from the other stance and swing phase control settings, it should allow for different weights of footwear, damping of inertia and terminal impact through an adjustable extension cushion.

### *System Development*

Early systems provided a hinge at the knee joint and then these hinge-type prostheses were modified to allow for foot dorsiflexion during knee flexion. Damping mechanisms for the knee rotation (mechanically passive knees) were then added and recently, electronically controlled systems have been introduced as adaptive systems with some built-in intelligence.

Adaptive prostheses can be divided into two categories; the first group of which are programmable and require that parameters be set for a particular user. Such devices, though better than predecessors, cannot autonomously adapt themselves to different terrains and walking. The second group of more intelligent adaptive prostheses can automatically adapt to different users and different environments by using sensory feedback mechanisms. The advantages of adaptive systems are [33]:

- they control the resistive torque or damping about the knee joint;
- can detect stumbles and other pathological behaviour and adapt;
- can provide more natural gait by using a sensory system to detect early and late stance;
- can help with overall shock absorption through provision of a more normal gait;
- can provide different levels of damping during the swing phase and also optimise damping levels at different walking speeds;
- they can detect conditions such as standing, sitting down and ascending or descending stairs and adapt accordingly.

### *Transfemoral Prosthesis*

A commercial example of an adaptive system is Blatchford's Intelligent Prosthesis (IP+) [28] which is stated to be capable of adapting to various modes of locomotion and also optimises the hip power available to the amputee. It is also stated that:

The prosthesis provides stance control ranging from minimal resistance to yielding lock, capable of detecting level walking, ramp descent, stair descent, standing and instances of stumble. The stance resistance is set to preprogrammed levels for each mode which matches the user's level of control [28].

Figure 11.10 shows some details of the passive control of the adaptive prosthesis. The prosthesis has been tested on many users and the feedback has been used to refine the system.



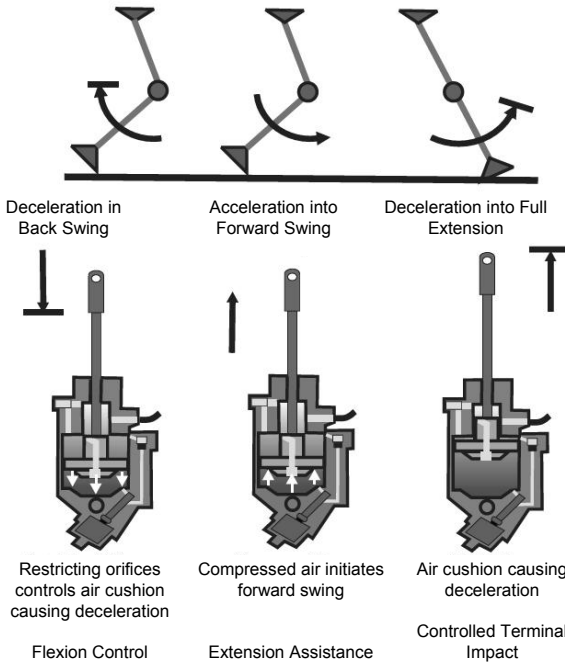

**Fig. 11.10** Schematic of Blatchford's Intelligent Prosthesis (IP+)<sup>6</sup>

An example of a user-adaptive system is a magnetorheological knee prosthesis developed at MIT<sup>7</sup> [33]. System design and development requirements include:

- understanding of normal human locomotion;
- components required for the intelligent prosthesis;
- algorithms needed for the control of the prosthesis;
- development, testing and verification.

The system as developed contains a magnetorheological (MR) actuator, angle and strain gauge force sensors, and the required electronic circuitry and battery. A rotary potentiometer at the knee joint is used to measure angular position (knee flexion angle) which can be differentiated to provide the knee angular velocity. Knee angular velocity was then used to determine whether the knee was flexing or extending. Force sensors were used to measure axial force to determine whether the prosthetic foot was on or off the ground. The force sensors were also used to measure knee torque. A microprocessor was utilised to control the device.

<sup>6</sup> A microprocessor adjusts the swing rate to compensate for the change of walking pace. The stepper motor controls air flow at a pre-determined position in the swing to create sufficient air resistance in order to restrict excessive flexion of the knee. The compressed air then provides assistance in quickly extending the knee for heel strike [32].

<sup>7</sup> Massachusetts Institute of Technology

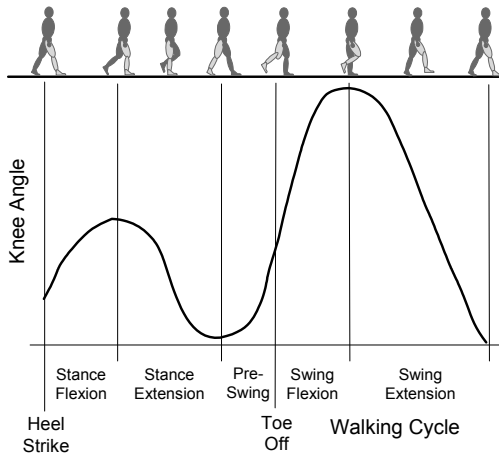

**Fig. 11.11** Normal walking phases and changes in knee angle [33]

To develop the control algorithms for such prostheses, five normal walking phases and the corresponding changes in the knee angle as illustrated in Figure 11.11 are typically considered. These five phases of normal human walking can then be used to establish five corresponding systems states, enabling a state machine controller to be used with the prosthesis.

After an initial system evaluation, the prosthesis must be clinically evaluated. Trials using both commercial non-adaptive and the developed adaptive prostheses establish the differences between these systems. Results obtained suggest that a user-adaptive prosthetic system with local mechanical sensors could help amputees to achieve more normal walking by adapting knee damping values to match the amputee's gait requirements.

### *Transfemoral Prostheses*

Below-knee prosthetic devices have tended to be essentially passive systems with their mechanical properties remaining largely unchanged during walking. As such, they cannot provide the functions of a natural ankle and foot and readily adapt to different speeds and terrains. Recently, below-knee prostheses have been and are being developed to incorporate more intelligence and be capable of mimicking human ankle-foot behaviour.

Transfemoral amputees using passive prosthetic systems usually experience problems such as non-symmetric gait patterns, slower self-selected walking speeds and higher gait metabolic rates. Research into human locomotion has shown that the metabolic power in transfemoral amputees is 20 to 30% more than that for able-bodied individuals. The human ankle performs more positive mechanical work than negative, though passive prostheses do not have the ability to provide net positive work [34].

The development of an active ankle-foot prosthesis to mimic human ankle-foot during walking should therefore follow a process that would:

- establish requirements and specifications for the prosthesis based on studies of human motion and biomechanics;
- design, model and simulate the proposed mechanical system;
- test and verify the mechanical system;
- design the required control system aimed at mimicking human gait;
- test and verify the control system;
- carry out clinical trials;
- carry out system refinements based on the trials results;
- verify system performance.

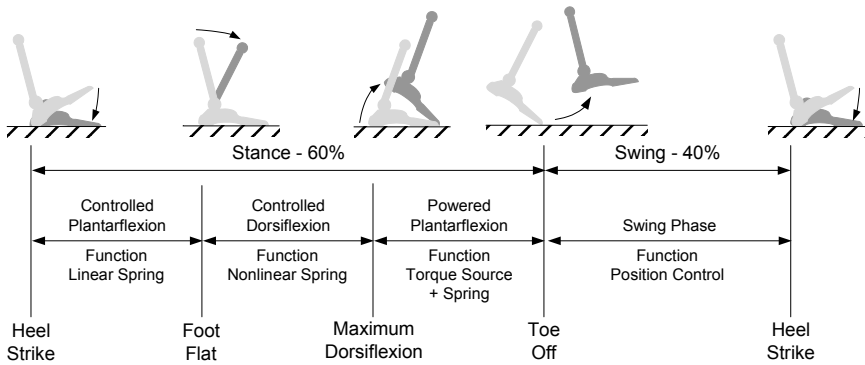

**Fig. 11.12** Ankle-foot relationships in normal human walking [after 34]

Considering an average person and the weight of the ankle-foot, the peak power and torque output requirements at the ankle during walking can be established. A biomechatronic system design approach can then be adopted to address the system challenges as well as the control strategies required to fulfil the specifications.

As indicated, in order to establish system requirements, it is necessary to review human walking, focussing on the biomechanics of the ankle. Figure 11.12 illustrates the ankle-foot relationships in normal human walking. From this, the system specifications can be established along with a model for the torque-angle relationships found in normal human walking as shown in Figures 11.13 [34].

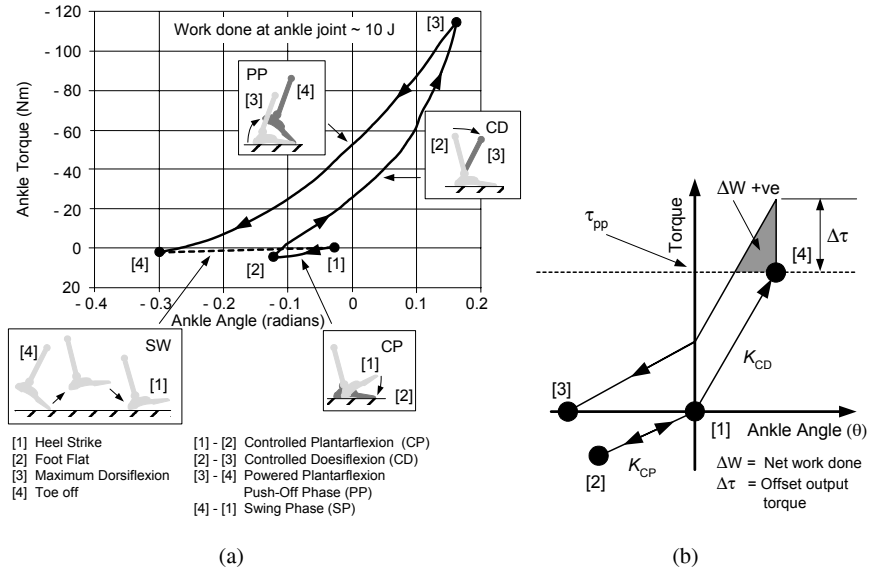

**Fig. 11.13** A typical torque-angle plot (75 kg person, walking speed 1.25 m/s) [after 34] (a) in normal human walking, and (b) simplified form

Based on the above models and the relevant analysis of the foot-ankle in normal human walking, the system specifications could then be along the lines of the following:

*System Specifications*

- The prosthesis should be of a weight and height similar to the intact limb.
- The system must deliver the required instantaneous output power and torque during push-off as suggested by Figure 11.13.
- The system must be capable of changing its stiffness as dictated by the quasi-static stiffness relationships of an intact ankle.
- The system must be capable of appropriately controlling joint position during the swing phase.
- The prosthesis must provide sufficient shock tolerance to prevent any damage to the mechanism during the heel strike.

Using the available data and system specifications, the parameter values can then be estimated for the system. An illustration of a powered ankle-foot prosthesis based on the above and using a series elastic actuator, and based on developments at MIT and elsewhere, is shown in Figure 11.14. The mechanical elements involved in this system include:

- a high power output motor;
- a ball screw transmission element;

- a series spring;
- a unidirectional parallel spring;
- a carbon composite elastic leaf spring prosthetic foot.

The elastic leaf spring foot is used to emulate the function of a human foot to provide shock absorption during foot strike, energy storage during the early stance period and energy return in the late stance period.

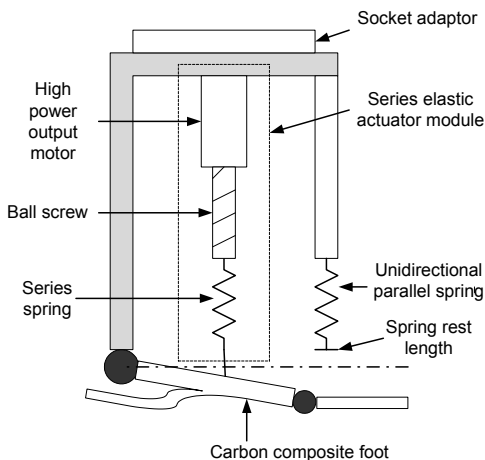

**Fig. 11.14** Mechanical design of a powered ankle-foot prosthesis [after 34]

Using computer based modelling and simulation methods, a comparison can be made of the joint torque/power-speed characteristic of the prosthesis and that of the normal human ankle during walking. This can then be supported by experiments in order to enable a comparison to be made between the experimental results and the simulation to verify the system.

For the control aspects of the system, various approaches can be considered including [35, 36]:

- a biomimetic EMG-controller;
- a neural Network EMG-controller;
- a hierarchical control with intent recognition.

Body motions in normal motion are controlled by the signals sent to various muscles. The challenge in controlling the prosthetic system is therefore how to measure and respond to the amputee's movement intent. One approach is to use electromyographic (EMG) signals measured from the residual limb as control commands. These are then usually used as discrete or binary levels of motion control. However, daily activities require continuous limb movement control. The difficulties with using EMG signals are that they are non-linear and have non-stationary characteristics.

In the case of a prosthetic limb, EMG signals from appropriate muscles could be collected and processed to estimate the intended movements. Based on this interpretation, the system should then provide the required command signals for the powered ankle-foot prosthesis to mimic human ankle-foot motion behaviour [35].

For a neural network based EMG-controller, the following strategy could be adopted based on the use of a standard multilayer, feed-forward neural network in which case:

- The inputs would be in the form of preprocessed EMG signals from the residual muscles.
- The structure of the network would be determined experimentally.
- The network would be trained using a standard back-propagation training algorithm.
- The output of the network would then be the estimated ankle position.

Results suggest that a biologically-motivated, model based approach may offer some advantages in the control of active ankle prostheses [35, 36].

The above discussion of the processes associated with the design and development of more intelligent prosthetic devices shows that studying and understanding human locomotion is key to the design and development of intelligent systems that should mimic the functionality of the human body. Adapting a biomechatronic approach from early stages of design could greatly produce a more successful outcome for future devices.

### ***11.3.3 Future Prosthetics***

The development of more intelligent prosthetic devices is likely to be associated with developments in areas such as:

- the understanding of human locomotion;
- improvements in interfacing to and supporting interaction between the nervous system and prosthetic devices;
- the development of new types of actuators, e.g., artificial muscles, to mimic human muscle functions;
- the development of new soft sensors;
- the enhanced integration of prostheses with human anatomy.

Extensive studies of human locomotion have been carried out. However, these studies are mainly carried out in laboratory environments and on relatively small numbers of subjects. The era of high-speed processing, large memory capacity, micro and nano technologies and new developments in sensors will allow even more comprehensive studies to be carried out on various human functions outside laboratory environments without interfering with daily activities. An example

would be research in soft sensing [37–41] and the ultimate integration of small wireless devices into clothing to monitor human locomotion in various terrains and environments. Such data, coupled with more advanced analytical methods, will enhance our understanding of normal human locomotion which in turn will support the design and development of more advanced intelligent prostheses.

A current issue with prosthetic devices is that there is no direct interaction between these devices and the human nervous system. Prosthetic devices, as part of the human body, should ideally receive control signals from the nervous system based on user intent. There should also be feedback to the brain similar to proprioceptor and mechanoreceptor signals. Research is addressing this issue as for instance with intelligent myoelectric upper limb prostheses using the targeted muscle reinnervation control scheme [42]. This is based on transferring the residual nerves of amputees to spare muscles in or near the residual limb, making additional muscle signals available for multifunctional prostheses. More degrees of freedom and higher speeds have been reported for these systems.

The further development of such techniques can produce even more independent signals to be used for myoelectric prosthetic control. A similar technique is also being tested to provide feedback to the amputee [43].

Development of neural control interfaces will greatly improve the future prosthetics. Advances in microelectronic systems coupled with a better understanding of the human nervous system and development of mathematical algorithms will allow the development of close-loop brain-machine interfaces. This should help the bidirectional interaction between prosthetic devices and the human nervous system [44].

Electroactive polymers are currently being developed for use as artificial muscles. Two categories of EAPs are Electric EAPs and Ionic Polymer Metal Composite EAPs. The vision for the future is that these materials may be used as artificial muscles based on their characteristic being close to biological muscles. Specific characteristics of EAPs include resilience, quiet operation, damage tolerance, and large actuation strains (stretching, contracting or bending). The advantages gained by using these materials are that they may eliminate the conventional mechanical components such as gears and bearings which add weight and cost, and increase the failure rate. Certain EAP materials also provide more lifelike aesthetics. It is also envisaged that biomimetic prosthetics could be developed using EAP materials [45, 46].

Electroactive polymers such as Ionic Polymer Metal-Composites (IPMCs) may also be used as sensors and a number of applications especially for micro-nano distributed sensors have been proposed. One typical application of IPMCs is as soft polymeric bend sensors. Research is being carried out to use these EAPs for monitoring ambulatory activities in certain patients [47]. EAPs may also be used in future prosthetic devices for sensing purposes.

Another area under development is the direct fixing of prosthetic devices to bone which is referred to as osseointegration. A titanium rod is screwed into the bone of the residual limb and the prosthesis is attached to the protruding rod. In an

ideal case, this should result in a biohybrid approach. It is claimed that this technique may help improvement in the amputee's perception of the environment which in turn may improve future prosthetic devices [44].

## 11.4 Conclusions

This chapter provided an introduction and overview to intelligent prosthetics. In order to design and develop such intelligent devices, it was suggested that a biomechatronics approach should be adapted. As the first step, a study of human locomotion is required and this was very briefly considered. Current prosthetic devices are mainly based on passive components and recently more intelligent commercial devices with microprocessor-controlled active components have appeared in the market. The development of sensors, actuators and machine intelligence can greatly speed up the design and development of more intelligent prostheses to mimic normal human motion. Examples of research and development in this area have been briefly discussed.

The future of prosthetic devices will see the use of a new generation of sensors and actuators, and more intelligent control. Particular research and developments include artificial muscle actuators and direct interfaces between the human nervous system and prosthetic devices.

## References

1. French MJ, (1994) *Invention and Evolution; Design in Nature and Engineering*, Cambridge University Press
2. [en.wikipedia.org/wiki/Bionic](http://en.wikipedia.org/wiki/Bionic)
3. Online Oxford dictionary;  
[dictionary.oed.com/cgi/entry/50022356?single=1&query\\_type=word&queryword=Bionics&first=1&max\\_to\\_show=10](http://dictionary.oed.com/cgi/entry/50022356?single=1&query_type=word&queryword=Bionics&first=1&max_to_show=10)
4. [en.wikipedia.org/wiki/Biomimetics](http://en.wikipedia.org/wiki/Biomimetics)
5. Online Oxford dictionary  
[//dictionary.oed.com/cgi/entry/20002098?query\\_type=word&queryword=Bionics&first=1&max\\_to\\_show=10&single=1&sort\\_type=alpha](http://dictionary.oed.com/cgi/entry/20002098?query_type=word&queryword=Bionics&first=1&max_to_show=10&single=1&sort_type=alpha)
6. [en.wikipedia.org/wiki/Biomechatronics](http://en.wikipedia.org/wiki/Biomechatronics)
7. [en.wikipedia.org/wiki/Human\\_body](http://en.wikipedia.org/wiki/Human_body)
8. Royston A (1998) *Essential facts, Human body*, Parragon
9. *Anatomica; the complete human medical reference*, Konemann
10. Oxford dictionary
11. Online Nursing and Allied Health encyclopaedia  
[www.enotes.com/nursing-encyclopedia/lower-limb-prostheses](http://www.enotes.com/nursing-encyclopedia/lower-limb-prostheses)
12. Whittle MW (2001) *Gait analysis, an introduction*, 3rd edition, Oxford: Butterworth-Heinemann
13. Online Nursing and Allied Health encyclopaedia  
[www.enotes.com/nursing-encyclopedia/gait and balance assessment](http://www.enotes.com/nursing-encyclopedia/gait_and_balance_assessment)



14. Kirby RL, Stewart-Gray JF, Creaser GA (1985) Usefulness of footprint-sequence analysis in lower-limb amputees, *Physical Therapy*, **65**(1):31–34
15. Ayyappa E (1997) Normal Human Locomotion, part1: Basic concepts and terminology, *J. Prosthetics and Orthotics*, **9**(1):10
16. Ayyappa E (1997) Normal Human Locomotion, part2: Motion, ground reaction force and muscle activity, *J. Prosthetics and Orthotics*, **9**(2):49
17. Saunders JB, Inman VT, Eberhart HD (1953) The major determinants in normal and pathological gait, *JBJS*, **35**-A:543–58
18. Inman V, Ralston HJ, Todd F (1981) Human walking, Williams and Wilkins, Baltimore:1–128.
19. Perry J (1992) Gait analysis; normal and pathological function, Slack:3-129 (chapters 1–6)
20. [emedicine.medscape.com/article/320160overview#section-PathologicalGait](http://emedicine.medscape.com/article/320160overview#section-PathologicalGait)
21. Orthotics and Prosthetics Online (2006) Materials Science: Producing Lighter, More Cosmetically Appealing O&P Devices, The O&P EDGE.  
[www.oandp.com/edge/issues/articles/200608\\_01.asp?searchquery=Ultralight+prostheses](http://www.oandp.com/edge/issues/articles/200608_01.asp?searchquery=Ultralight+prostheses)
22. Rothschild VR, Fox JR, Michael JW, Rothschild RJ, Playfair G (1991) Clinical experience with total thermoplastic lower limb prostheses, *J. Prosthetics and Orthotics*, **3**(1):51
23. Pithawa AK, Singh BG, Ravindranath BG (2006) Clinical appraisal of indigenous below knee endoskeletal carbon fibre prosthesis, *Medical J. Armed Forces India*, **62**(2)
24. [www.amputee-coalition.org/military-instep/cosmesis.html](http://www.amputee-coalition.org/military-instep/cosmesis.html)
25. [www.emedicine.com/asp/dictionary.asp?keyword=proprioception](http://www.emedicine.com/asp/dictionary.asp?keyword=proprioception)
26. Jinung A (2003) Modelling of a magnetorheological actuator including magnetic hysteresis, *J. Intelligent Materials and Systems*, **14**(9):541–550.
27. Pratt GA, Williamson MM (1995) Series Elastic Actuators, IROS 95, Pittsburgh
28. [www.endolite.co.uk/products/knees/smart\\_adaptive/smart\\_adaptive.html](http://www.endolite.co.uk/products/knees/smart_adaptive/smart_adaptive.html)
29. [www.cleg.ottobock.com/index.php?id=67&L=1](http://www.cleg.ottobock.com/index.php?id=67&L=1)
30. [www.ossur.com/lisalib/getfile.aspx?itemid=6996](http://www.ossur.com/lisalib/getfile.aspx?itemid=6996)
31. Zahedi S, Sykes A, Lang S, Cullington I (2005) Adaptive prosthesis – a new concept in prosthetic knee control, *Robotica*, **23**:337–344.
32. Zahedi S, Lower limb prosthetic research in the 21st century, *ATLAS of prosthetics*.  
[www.endolite.co.uk/clinical\\_studies/clinical\\_studies\\_pdf/Lower\\_Limb.pdf](http://www.endolite.co.uk/clinical_studies/clinical_studies_pdf/Lower_Limb.pdf)
33. Herr H, Wilkenfeld A (2003) User-adaptive control of a magnetorheological prosthetic knee, *Industrial Robots*, **30**(1):42–55.
34. Au SK, Weber J, Herr H (2007) Biomechanical design of a powered ankle-foot prosthesis, *Proc. 10th Int. Conf. on Rehabilitation Robotics, ICORR2007*:298–303.
35. Au SK, Bonato P, Herr H (2005) An EMG-position controlled system for an active ankle-foot prosthesis: An initial experimental study, *9th Int. Conf. on Rehabilitation Robotics, ICORR2005*
36. Sup F, Varol HA, Mitchell J, Withrow TJ, Goldfarb M (2009) Self-Contained Powered Knee and Ankle Prosthesis., *11th Int. Conf. On Rehabilitation Robotics, ICORR 2009, Paper 0024*
37. Abadi S, Dehghani A, Nelson EA (2007) Venous ulceration and the measurement of movement, *Abstracts 16th Annual Meeting of the European Tissue Repair Society (ETRS), In Wound Repair and Regeneration* **15**:A73
38. Abadi S, Nelson EA, Dehghani A (2007) Emerging Technologies in the Measurement of Lower Limb Movement in Relation to Venous Ulceration, *Abstracts of 17th Annual Meeting of the European Tissue Repair Society (ETRS), In Lower Extremity Wounds*, **6** (3):187–188.
39. Abadi S, Nelson EA, Dehghani A (2007) Venous Ulceration and the Measurement of Movement: A Review, *J. Wound Care* **16**(9): 396–402
40. Young AD, Ling M, Arvind DK (2007) Orient-2: A real-time wireless posture tracking system using local orientation estimation, *4th Workshop on Embedded Networked Sensors*; 53–57
41. Arvind DK, Bates A (2008) The speckled golfer, *Proc. 3rd ICST Int. Conf. on Body Area Networks, Tempe, Article No 28*

42. Kuiken TA, Dumanian GA, Lipschutz RD, Miller LA, Stubblefield KA (2005) Targeted muscle reinnervation for improved myoelectric prosthesis control, Proc. 2nd Int. EMBS Conference on Neural Engineering
43. [en.wikipedia.org/wiki/Targeted\\_reinnervation](http://en.wikipedia.org/wiki/Targeted_reinnervation)
44. Aaron RK, Herr H, Ciombor DMK, Hochberg LR, Donoghue JP, Briant CL, Morgan JR, Ehrlich MG (2006) Horizons in Prosthesis Development for the Restoration of Limb Function, J. the American Academy of Orthopaedic Surgeons, **14**(10):198–204
45. Bar-Cohen Y (2004) Bionic Humans Using EAP as Artificial Muscles Reality and Challenges; Int. J. Advanced Robotic Systems, **1**(3):217–222.
46. Herr H, Kornbluh R (2004) New horizons for orthotic and prosthetic technology: artificial muscle for ambulation; Smart Structures and Materials: Electroactive Polymer Actuators and Devices (EAPAD), Proc. SPIE, **5385**:1–9.
47. Abadi S, Dehghani A, Nelson EA (2008) A Soft Sensing Method for Monitoring Ambulatory Activities of Patients with Venous Ulceration, 4th IET Int. Conf. on Advances in Medical Signal and Image Processing, Santa Margharita

# Chapter 12

## Education in Mechatronics

Vladimir V. Vantsevich<sup>1</sup>

### 12.1 Introduction and Background

Education in mechatronics is a relatively new discipline in engineering education, as is mechatronics itself. At the first developmental stages about 30–35 years ago, the content of courses and programs in mechatronics formed spontaneously and were primarily based on the developer’s professional experience. As a rule, mechatronics courses were initiated independently by professors in mechanical or electrical and computer engineering departments. In the case of the former, this was generally through the inclusion of courses on microprocessors and control within a primarily mechanical engineering programme while in the latter, the primary emphasis tended to be on the electrical and electronic components of mechatronic systems. This divergence of approach is consistent with the evolutionary structure of mechatronics shown in Figure 12.1.

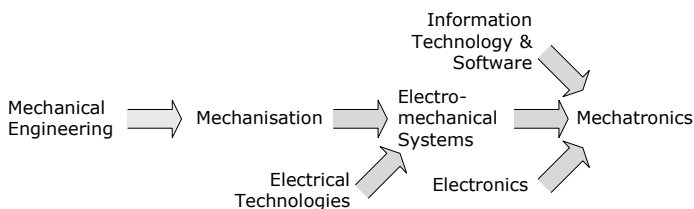

**Fig. 12.1** The evolution of mechatronics<sup>2</sup>

During the 1990s, mechatronics became a common elective course and frequently, also a required course in many undergraduate mechanical engineering systems worldwide [1]. Nevertheless, during that time, in the overwhelming majority of cases, engineers resorted to mechatronics as a part of their work, meaning that it was essentially self-taught. As a rule, this occurred, and still is occurring, due to collaborations between mechanical, electrical and computer

<sup>1</sup> Lawrence Technological University, USA

<sup>2</sup> See also Chapter 1 – *Introduction*, Figure 1.1

engineers. This often resulted in a ‘trial and error’ manner of doing things since the engineers involved had different backgrounds, and indeed often used different engineering terminologies<sup>3</sup>.

Gradually, the discipline of mechatronics evolved as modifications to engineering courses in existing engineering programs to the creation of new degree programs in mechatronics, culminating in the creation of organisations devoted exclusively to the field of mechatronics [2, 3]. This process was to a large extent propelled by active scientific studies in the field of mechatronic systems. Analysis reveals that integration of various teaching courses into mechatronics took place in the research activities of some of the American universities that have established research laboratories in this field, including:

- Mechatronic Laboratory at MIT;
- Advanced Mechatronics Laboratory in Carnegie Melon University;
- General Robotics, Automation, Sensing and Perception [GRASP] Laboratory in the University of Pennsylvania.

Gradually, the establishment of research laboratories in mechatronics inevitably led to creating courses and curricula in this field [4–6]. Mechatronics became increasingly more popular as an academic programme during the period from the 1990s to date [1, 7–12]. Programmes at both undergraduate and graduate levels are becoming more popular and flourishing in Europe, Asia and America<sup>4</sup>. More than 100 research and educational institutions in mechatronics belong to the International Network of Mechatronics Universities [13]. The goal of the network is to exchange experiences in mechatronic research and education.

Although nearly 20 American universities (see Table 12.1) participate in this network, there remains a general lack of comprehensive educational programmes in mechatronics in the US. Very few universities offer educational programs in the field, further, not many industrial enterprises, even those associated with mechatronic systems, are ready to accept degrees in mechatronic systems engineering as an important addition to traditional degrees.

In general, mechatronic systems are usually classified as a function of the dimensions of the objects, i.e., of the systems themselves [14]:

- conventional and miniscale mechatronic systems;
- Micromechatronic systems (MEMS);
- Nanomechatronic systems (NEMS).

This approach to systems classification could also be introduced into mechatronic education programmes. This is because the set of courses in a programme is significantly determined by the physical nature of the systems that

---

<sup>3</sup> See also Chapter 3 – *The “Revolution”*: A Small Company Revived, Section 3.1

<sup>4</sup> Note that there are differences in terminology between different countries. Thus in the US, a *course* is an element within a *degree programme* which itself may be structured around a series of *modules* in which courses are brought together. Whereas in the UK and elsewhere, individual subject *modules* are combined to create a *degree course*.

are investigated<sup>5</sup>. It can also be argued that the three groups overlap and support each other. Thus, at the lowest level of a large-scale system, such as automotive NEMS technologies, the following level will certainly see MEMS and so on. Each level can still be described in mechatronic terms, as can the complete system.

**Table 12.1** North American Universities that participate in the International Network of Mechatronic Universities

California Polytechnic State University, San Luis Obispo	San Diego State University, San Diego
California State University, Chico	San José State University, San José
Carnegie Mellon University, Pittsburgh	Stanford University, Stanford
Clemson University, Clemson	University of California, Berkeley
Colorado State University, Fort Collins	University of Illinois, Urbana
Georgia Institute of Technology, Georgia	University of Washington, Seattle
Kettering University, Flint	University of Waterloo (Canada)
Ohio State University, Columbus	Virginia Polytechnic Institute and State University, Blacksburg
Rensselaer Polytechnic Institute, Troy	

A survey of US universities showed California State University, Chico, is the only academic institution that offers a BS<sup>6</sup> in Mechatronic Engineering. North Carolina State University has a concentration in mechatronics in its MS<sup>7</sup> programme in Mechanical Engineering and in its MS programme in Electrical Engineering. The mechanical engineering department in Rensselaer Polytechnic Institute (RPI) in New York has two senior-elective courses in the field of mechatronics which are also open to graduate students. RPI also has a mechatronic teaching lab.

The Lawrence Technological University in Michigan and the University of Denver in Colorado all offer an MS degree in mechatronic systems engineering programmes. The University of Pennsylvania in Philadelphia offers the Master's of Science and Engineering in Robotics. This is a programme that can be regarded as being concerned with robotics, which is a specific field of mechatronic systems. Many other universities in the US offer courses that are not designated specifically as mechatronics, though in fact deal with this engineering discipline.

The balance of academic courses and degree programmes that has become established in universities in the field of mechatronics should be regarded as successful. In fact, the introduction of undergraduate courses in the BSME<sup>8</sup> curricula definitely advances the level of preparation of students as compared with the typical set of courses in traditional mechanical engineering programmes. A

<sup>5</sup> See also Chapter 1 – *Introduction*, Section 1.2.3

<sup>6</sup> Bachelor of Science

<sup>7</sup> Master of Science

<sup>8</sup> BSME – Bachelor of Science in Mechanical Engineering

Master of Science in Mechatronic Systems Engineering (MSMSE) programme opens up new vistas for BSME, BSEE<sup>9</sup> and BSCE<sup>10</sup> graduates, and also for experts with a BSMCS<sup>11</sup> degree, who, as experience shows, can be accepted in an MSMSE programme provided that they have sufficient practical experience in synthesising mechatronic systems (approximately five years). At the same time, a degree obtained after graduating from a MSMSE programme can be considered a good supplement to MSME, MSEE, MSCE and MSAE<sup>12</sup> degrees.

Upon earning an MS in Mechatronic Systems Engineering in addition to their original masters degrees, these individuals are in much greater demand for work in industries such as, aerospace and automotive, robotics and manufacturing, military-vehicle and autonomous vehicle engineering, defence systems engineering, biomedical engineering, truck and agricultural tractor engineering, climate control systems engineering, materials processing, machine test systems engineering, communications system and media as well as both large and small businesses in a wide variety of areas.

Currently, the question of whether mechatronics should or should not be taught is no longer under discussion as mechatronics has established its place in engineering education. In spite of the different definitions and terminology used, the integrative nature of mechatronics is no longer in doubt and is commonly accepted. Rather, the principal questions currently under discussion are “*What?*” and “*How?*”.

The question “*What?*” addresses the content of mechatronics teaching curriculum while the question “*How?*” formulates the problem as to how, using what methodological approaches and technical means, to successfully teach mechatronics.

These two principal questions (actually two fundamental problems) stem from the fact that mechatronics touches upon principles of several natural and applied sciences. The mechatronic system contains mechanical, electrical and electronic, computer and other components. All of them are of basically different physical nature and are the subjects of educational programmes on their own. At the same time, structural and functional combination of these components into a mechatronic system should bring about a synergetic improvement of the quality of this system. On the other hand, the mechatronics education system should precisely teach how such a synergy in designing mechatronic systems can be attained.

---

<sup>9</sup> BSEE – Bachelor of Science in Electrical/Electronic Engineering

<sup>10</sup> BSCE – Bachelor of Science in Computer Engineering

<sup>11</sup> BSMCS – Bachelor of Science in Math and Computer Science

<sup>12</sup> MSME – Master of Science in Mechanical Engineering  
 MSEE – Master of Science in Electrical/Electronic Engineering  
 MSCE – Master of Science in Computer Engineering  
 MSAE – Master of Science in Automotive Engineering

As suggested in Chapter 1<sup>13</sup>, in mechatronics education, the concern in course and programme design has always been that of striking an appropriate balance between providing the necessary understanding of core technologies with the ability to develop solutions that integrate those technologies. As an example of a specific engineering field that illustrates the strategic approach to the development of mechatronic education, consider the case of ground vehicle engineering. The experience in teaching mechatronic systems engineering with applications to ground vehicles and our research collaboration with the industry show that the mechatronics engineer doesn't require a familiarity with vehicle dynamics. Knowledge of the principal concepts of vehicle dynamics is sufficient to enable the mechatronics engineer to be able to interact professionally with vehicle dynamics engineers and other experts in developing and implementing a vehicle mechatronic system. The contribution of the mechatronics engineer to the synthesis of such a system cannot be overestimated. Without the integrative approach that is provided by mechatronics, the experts in the other fields will always encounter difficulties not only in synthesising the system, but also in communicating with one another.

The challenge facing the mechatronic course designers is therefore that of striking a balance between establishing detailed knowledge and providing the ability to act in an integrating role within a wide range of environments. The number of the fields of knowledge and technologies in which the integrative approaches of mechatronics is needed is constantly growing. Therefore, the engineering lexicon has acquired new terms such as optomechatronics and mechamatronics<sup>14</sup> [15, 16].

In this context, there therefore exist a large number of issues that have a direct bearing both on the structure and content of courses and programmes, and on the use of technical means in mechatronics education. In developing and retaining the balance between the components of mechatronic programmes, the following can be considered as significant:

- mathematical modelling and mechanical design of mechatronic systems;
- control algorithm design;
- mechatronic system implementation.

Some courses and educational programmes exhibit a significant “leaning” toward control design and individual directions in mechatronic systems implementation, including sensors and actuators, signal processing, software and data acquisition and certain others. Analysis of available textbooks, monographs and reference literature shows that questions of mechanical design of mechatronic systems require particular attention [18–19]. There are very few books on the market that are concerned with mechanical design aspects of mechatronic systems. They mostly reflect the traditional problems of mathematical simulation of

---

<sup>13</sup> See Chapter 1 – *Introduction*, Section 1.2.3

<sup>14</sup> The *ma* in mechamatronics stands for materials.

systems and of mechanical design. At the same time, mechanical design of mechatronic systems differs from the design of conventional mechanical systems in that the impact of the electronics and software on the mechanical elements must be taken into account. This lack of publications arises because the mechanical design of mechatronic systems is a relatively new area of study that was, until recently, not given the attention it deserves. In addition, the information that has been and is accumulated by companies working in this field is usually proprietary and confidential.

The mathematical simulation of mechatronic systems also requires the constant attention of both the programmers and the programme users – professors and students [17, 20]. The simulation of mechatronic systems with components of different physical nature is a challenge that needs to be addressed in selecting the mathematical framework, methods of solution, and analysis of the results of such simulation.

Experience in developing and teaching courses on the control of mechatronic systems shows that such courses cannot be constructed by copying similar courses that are traditionally delivered in electrical and computer engineering departments. The principal difference between the two consists in the fact that the control courses read in mechatronic programmes must include the in depth analysis of the approaches to plant modelling and model-based control algorithm development.

There exists another basic requirement for those Modules 1 and 2 courses in mathematical modelling and mechanical design, and control upon which hinges the success of the entire mechatronics programme. These courses must organically incorporate a high analytic level with a focus on the practical application of the material being presented, i.e., product-oriented courses. For this, the lecture material should be presented in a manner that would foster the development of the analytic skills of the students. This is attained, among others, by continuity of the material analysed in the different courses, i.e., the students should be able to follow the logical interrelationships of the topics and illustrative examples from the real engineering world upon transition from one course to another.

The emphasis on practicality in Module 1 and 2 courses can be strengthened by including into them computer workshops, laboratory projects that utilise mechatronic systems, team projects and so forth, all of which promote the acquiring of hands-on experience. At the time of developing a mechatronic programme, the course designer will be faced with the problem of setting up of a mechatronic systems laboratory with the pertinent equipment, both hardware and software. The principal recommendation here may be as follows. For graduate programmes in mechatronic systems engineering, all the laboratory equipment and computer programming facilities should be compiled from the range of mechatronic systems that are produced and used by industry. This is the necessary condition for developing product-oriented courses, causing the graduate students to develop the related and relevant practical skills. In undergraduate-level courses, it is advisable to strengthen the deductive component of the educational process by using specifically designed laboratory set-ups that explain the nature of the processes.



The approach described above for developing Module 1 and 2 courses should also be taken into account in developing Module 3 (mechatronic systems implementation) courses. That is, it is necessary to establish a logical interrelation of courses at all modules that could be expressed by the following relationship:

system modelling and design – control algorithm synthesis – hardware implementation.

The mechatronic systems laboratory should facilitate the integration of students' knowledge gained in various courses by providing appropriate set-ups.

Course and programme outcomes assessment is a significant element in developing a mechatronics education programme. The term “outcomes assessment” designates quantitative estimation (measurement) of student achievements in the study of course material, comparison of the results attained by the students with the expected learning outcomes and, finally, using the results of this comparison for further improvement of courses. Practical implementation of this assessment must be based on fully specific objectives on the basis of programme goals that are the expected learning outcomes of the students. It is then necessary to establish measurements that would allow for the assessment of the extent of mismatch between the expected learning outcomes and the actual student achievements.

## **12.2 The Development of the Master of Science in Mechatronics Systems Engineering at Lawrence Technological University**

The above challenges were dealt with and recommendations were worked out upon analysis of different courses and programmes, and research implemented by a large number of institutions of higher learning and laboratories in mechatronic systems engineering, and also in the course of developing and teaching of an MS in Mechatronic Systems Engineering programme in Lawrence Technological University, Michigan. Consider the principal conceptual features of the structure of this programme, the content of its courses and also the equipment and directions of teaching and research work in the Laboratory of Mechatronic Systems.

### ***12.2.1 Rational for Course Development***

The programme was developed and offered so as to address the needs and requirements of industry, economic and the labour situation in the State of Michigan. Michigan's industry and economy are facing many challenges and over recent years, Michigan has lost more than 170,000 manufacturing jobs, the largest single state share of the 2 million lost nationwide. While other states were

positioned to replace those jobs with high-skilled, high-wage jobs in emerging and technology-based industries, Michigan was not [21].

A detailed analysis of the transportation equipment and manufacturing industries reflect a drop in production jobs in the auto industry, and the corresponding job loss that has occurred since 1990. This job loss has been substantial. Employment fell 17% in the automotive industry as well as in the broader manufacturing sector. As a result, manufacturing in Michigan supplied only 16% of jobs in the state, down from 21% in 1990. Productivity improvements, international competition, and the impact of the 2001 recession all played a role in the job cuts in the automotive and manufacturing sectors.

In view of the above, a primary goal formulated by the Michigan State Government has been to enhance the future productivity and competitiveness of Michigan's businesses and industry. Michigan industries that are projected to have sizable employment growth are concentrated in emerging technological areas with medical, technical, and educational services as the number one priorities.

The expected high-growth industries in Michigan will generate job opportunities for skilled workers as economic growth accelerates. The demand for highly skilled, value-oriented individuals who will be successful in a knowledge-based economy will increase. Based on these criteria, the Michigan Governor's office developed a list of critical occupations including mechanical engineers, computer systems analysts, and computer software engineers among others.

A major impact on Michigan's economy stems from globalisation. To be attractive to firms and individuals in a global world, Michigan must have qualities of place, and appropriate human capital to compete. Further, it needs to offer regional communities that support a synergy among clusters of firms with the research, practice base, and highly educated population required to support job creation.

Elsewhere, professional and business services have recorded the fastest job expansion in Michigan during the last fifteen years. The five relevant sectors; professional and business services, educational and health services, natural resources and construction, leisure and hospitality services, have recorded a growth rate of at least double the average for all industries since 1990. Four of the five are in the rapidly expanding service sector, demonstrating the shift in jobs in the State from production based to service and knowledge based economy.

Based on the above, it may be concluded that to improve the situation in Michigan's economy during the coming years, there should be a significant move in the industry toward a new engineering philosophy, e.g., towards the emerging, technology-based industries with sizable employment growth in medical, technical, and educational services. However, to make a real move forward, industry should have access to professionals in new areas of knowledge, especially in those advanced technologies such as mechatronics and biomechanics, nanotechnologies and smart structures and information technology that often cross the boundaries of existing specialties. In response to these conditions, the Michigan Legislature recently launched its 21st Century Job Fund, a \$394 M programme designed to jumpstart Michigan's economy. It will diversify and

nurture the economy by focusing resources towards the development and commercialisation of competitive-edge technologies such as mechatronics.

To address the needs of industry and to be competitive with the increasing educational services required in Michigan, Lawrence Technological University has taken an initiative to create a new graduate educational programme in the field of mechatronics systems engineering. Such an initiative leads to many challenges, but at the same time, brings advantages for both the industry and the University, and for the educational system in general. In order to attain the greatest positive effect, the Master of Science in Mechatronic Systems Engineering programme was developed as a product-oriented programme whose graduates are taught not only the principles of mechatronic systems design as a whole, but are also provided with fully defined knowledge and practical experience in two aspects:

1. design of mechatronic systems for ground vehicles, including autonomous and unmanned vehicles for a variety of applications, including heavy-duty trucks and automotive cars, farm tractors and tracked vehicles, etc;
2. design of industrial robots.

The graduates will:

- i. learn principles in mechanical system design for mechatronic systems;
- ii. develop strong mathematical and application skills in analytical and adaptive dynamics of mechatronic systems based on direct/inverse dynamics;
- iii. provide expert knowledge in the areas of logic design of mechatronic systems, of classical and modern intelligent/robust control algorithm development, and designing mechanical systems in conjunction with their control systems (mechatronic systems);
- iv. develop analytical skills in the optimisation of mechatronic systems;
- v. learn principles of designing and be skilled in the implementation of control algorithms in hardware – mechatronic systems.

Developing a curriculum in mechatronics systems engineering requires a delicate balance between (a) offering an appropriate number and a sequence of courses that reflect the subject of mechatronic systems engineering and in (b) providing the course implementation with minimum changes in the existing structure of the university's departments. These two issues are interrelated and should be concurrently addressed. Indeed, any mistakes in packing a curriculum with courses would lead to a lower professional level and to inefficiency of the programme. At the same time, the programme should be implemented within the conventional structure of existing engineering departments.

In order to expediently start the new programme and minimise the burden on university budget, personnel, and infrastructure, Lawrence Tech decided to begin this programme through its existing Mechanical Engineering Department with collaboration and support from Electrical and Computer Engineering, and the Mathematics and Computer Science Departments.

There is an interesting observation that the content of a mechatronics programme reflects the department that heads the programme. This is seen even from the titles of books published in the mechatronics field. Usually, professionals with electrical and a computer engineering background name their books and courses as electro-mechanical systems. Professionals from the mechanical engineering field typically use the word “mechatronics”. There is a fundamental problem behind this terminology that does not appear obvious at first sight. The problem is that those electrical engineering faculties tend to bring more electrical motor controls to the mechatronic systems engineering programme. In contrast, mechanical engineering faculties usually apply a systems approach to mechatronic systems engineering by considering system modelling and simulation to be the important and necessary components of the core programme.

### ***12.2.2 Programme Structure and Implementation***

Lawrence Tech addressed the issue of the “mechanical – electrical balance” by incorporating the Maths and Computer Science (MCS) and Electrical and Computer Engineering Departments (ECE) in supporting roles with the Mechanical Engineering (ME) Department providing leadership of the programme. This was a critical and timely decision. In many cases, mechatronics is considered a “hands-on” field that just integrates mechanical and electrical/electronic fields. Bringing in the MCS Department added a rigorous math component to the programme, making the programme not only “hands-on”, but analytically founded in a way that enhances engineering content and also confirms the Master of Science level of the programme. At the same time, bilateral collaboration between three departments leads to a synergy and new philosophical concept of the areas that make mechatronics a science and not solely an engineering field. Indeed, these three departments bring new foundations to the programme by merging their scientific and technological principles with each other. These foundations are:

- mathematical modelling of mechatronic systems in motion and optimisation (ME-MCS);
- software for simulating intelligent system behaviour (ME-MCS);
- robust/intelligent logic control algorithms (ME-ECE);
- mechanical systems with electrical and electronic hardware, e.g., mechatronic systems (ME-ECE);
- software for implementing robust/intelligent logic control algorithms (ECE-MCS);
- programmable logic devices (ECE-MCS).

These new foundations comprise the basis for the programme and are shown in Figure 12.2. Thus, involving three departments is advantageous by bringing together both the analytical and project-based practical principles associated with

mechatronic systems engineering. Also, it provides better interdepartmental collaboration in both teaching and collaborative research.

The treatment of mechatronic systems engineering presented in Figure 12.2 is, in the author’s opinion, in agreement with the currently standard approaches to compiling the list and content of engineering programmes analysed in this field [11, 18, 22]. At the same time, the MSMSE programme that was developed contains a number of innovatory approaches to the composition and content of courses, specifying the laboratory equipment and use of software to collaboration with industry and governmental scientific, and technological agencies and professional societies.

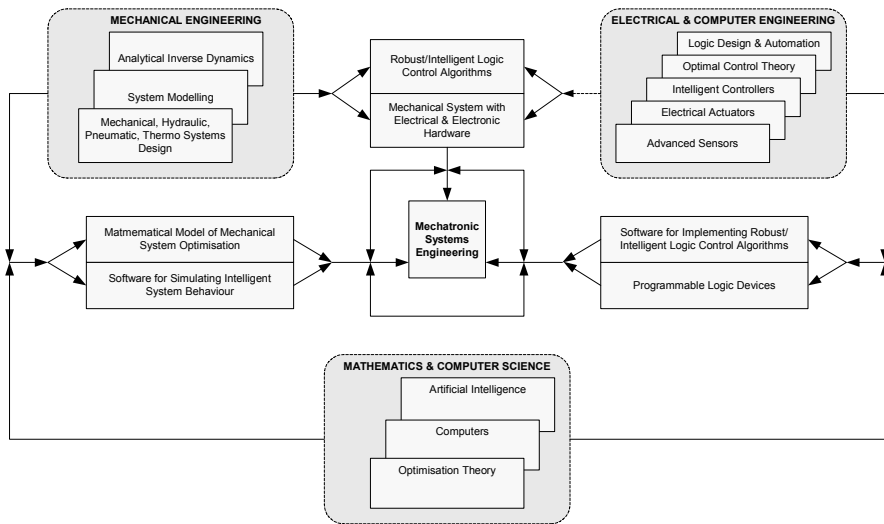

**Fig. 12.2** Mechatronic systems engineering

Consider the problems of the types of course and their contents. Historically, the professional background and research interests of faculty members define the technical orientation and research interests of the courses and curricula. On one hand, this is good as it makes courses stronger. On the other hand, if the courses solely follow the research interests of the programme leader, the programme can become stagnant and narrow in its focus and development. To provide diversity is one of the important goals of the programme. This is achieved by; (i) arranging an appropriate course structure that covers the main current needs of the industry and by (ii) keeping a balance between inviting experts from the industrial field associated with a particular system design, and maintaining analytical and engineering level of the programme by inviting representatives from those branches of the industry which provide analytical/software tools and hardware instrumentation to solve engineering problems.

To address these concerns, all courses should be product-oriented and be based on appropriate analytical principles that differentiate between the courses in the

proposed MSMSE programme and similar courses in other programmes. This is to make the programme competitive with others. Figure 12.3 presents eight core-courses that can be classified into three modules.

The first module of Figure 12.3 comprises the courses MSE6113, Analytical & Adaptive Dynamics in Mechatronic Systems, and MSE6123, Mechanical Design of Mechatronic Systems/Robots. The first of these is concerned with fundamentals of mathematic modelling of mechatronic systems.

As previously mentioned, there are few books on the specifics of mechanical design of mechatronic systems. The course MSE6123 is intended to fill this void and to teach students the principles of mechanical design of mechanical systems when they become parts of mechatronic systems.

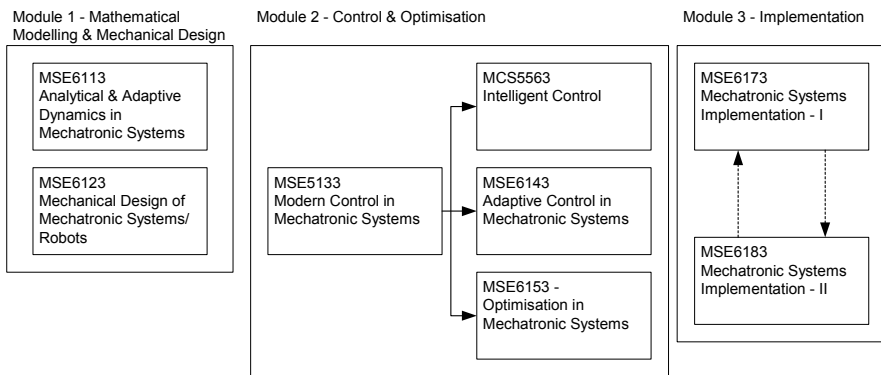

**Fig. 12.3** Requisite core courses and associated modules

A second group of core-courses shown in Module 2 of Figure 12.3 is comprised of control and optimisation courses. Optimal control in mechatronic systems is a part of the course in Optimisation in Mechatronic Systems. The mechatronic control courses differ from traditional courses in that the mechatronic control algorithms are built on a mathematical model that represents the entire system, including the various actuators and motors. Conventional control courses are often limited to motor controls only.

A particular challenge in working out the curriculum and content of the courses making up the programme was in incorporating into them of the two themes of ground vehicle mechatronic systems engineering and the design of industrial robots, background of which is given to all students. To support this, the six courses of Modules 1 and 2 shown in Figure 12.3 were developed as product-oriented courses in which, in addition to the general theoretical content, were presented with analytic problems, laboratory work and computer workshops reflecting specific aspects of mathematical modelling, mechanical design and control system synthesis. As is seen from Figure 12.3, the MCS5563 course was developed with the Math and Computer Science Department.

An important objective of the two Module 3 courses of Figure 12.3 is to develop practical skills in mechanical design and implementing control algorithms

into real mechatronic systems. Regarding the initial courses, Mechatronic Systems Implementation I was then developed as a course on the design of mechatronic systems for ground vehicles, whereas Mechatronic Systems Implementation II focused on the design of industrial robotic systems and also includes measurement systems topics. These two courses and their incorporation in the MSMSE programme promotes the striking of a balance between teaching theoretical/analytical courses and training in hardware implementation skills, something which is a real challenge to achieving a successfully mechatronics programme [23].

All the elective courses have also been clustered into three modules shown in Table 12.2. Such a clustering of elective courses makes it possible for students to gain deeper insight into the fields of mechanical, electrical and computer engineering, mathematics and computer science or in a specific field of mechatronic systems engineering. Thesis work in either vehicle systems or industrial robots, or taking two elective courses completes the specialist programme.

**Table 12.2** Elective Courses in MSMSE programme<sup>15</sup>

Courses in Mechanical Engineering	Courses in Electrical and Computer Engineering; Math and Computer Science	Courses in Mechatronic Systems Engineering
EME5213 – Mechanical Vibrations	EEE5533 – Digital Control Systems	MSE6283 – Autonomous Wheel Power Management Systems
EME5223 – Advanced Mechanics of Materials	EEE5294 – Advanced Microprocessors	MSE6233 – Special Topics in Mechatronic Systems Engineering
EME5143 – Internal Combustion Engines	EEE5653 – Digital Signal Processing	MSE6243 – Graduate Directed Study
EME5153 – Applied Thermodynamics	EEE5624 – Computer Vision	MSE6213 – Stability in Mechatronic Systems <sup>16</sup>
EME6123 – Automotive Structural Analysis	MCS5503 – Intelligent Systems	MSE6223 – Algorithmic Synthesis of Complex Mechatronic Systems <sup>10</sup>
EME6113 – Fatigue Analysis		MSE6xx3 – Mechatronic Manufacturing Systems <sup>10</sup>
EME6213 – Fundamentals of Acoustics		MSE7xx3 – Robust Mechatronic Systems <sup>10</sup>
EME6493 – Theory of Plates & Shells		EME6623 – Automotive Control Systems – I
EME6553 – Structural Stability		EME6623 – Automotive Control Systems – II

<sup>15</sup> Some courses may have prerequisites listed in the University catalogue.

<sup>16</sup> Course under development at the time of writing

## System Dynamics

The idea behind the concept of these clusters of courses is to teach mechatronics as a new philosophy in engineering and to have students implement new knowledge by experiencing a process of doing real engineering projects. To this purpose, the first course, Analytical and Adaptive Dynamics, starts with an introduction to mechatronic systems engineering and then goes on to system mathematical modelling.

The course is different from conventional courses in systems dynamics which traditionally are either analytically strong with little applications to engineering fields or applied with little of the analytical materials needed to develop the analytical skills of students. The proposed course sets out to balance both components by including topics such as inverse dynamics; programmable motion and the stability of mechatronic systems, and by then, arranging the topics into a sequence of product modelling processes

Newton formulated what is now known as the direct and inverse dynamics problems [24]. The direct problem is to determine kinematic parameters of a body subjected to a given set of forces. The inverse problem is to determine forces that should be applied to a body to maintain the required kinematic parameters of the body in motion.

The inverse approach is used in many research and engineering fields. Examples include mechanics of deformable bodies [25], geophysical inverse methods [26], optical devices [27], and various applications to spacecraft dynamics [28]. Aspects of inverse dynamics are examined in certain books on robotic technology [29, 30]. However, modern ground vehicle dynamics have developed based on the direct dynamics approach, which results in a better understanding of kinematic response/response of a vehicle subjected to applied forces [31–34]. A more advanced vehicle dynamics and then vehicle performance control can be achieved using the inverse approach, e.g., a vehicle is driven by forces that provide the required kinematic parameters and minimum (or maximum) values of quality functionals (also called criteria) of the vehicle operational properties [35–41].

A thorough understanding of the significance of the inverse approach and inverse dynamics has specifically been included within the educational structure of the MS in Mechatronic Systems Engineering programme at Lawrence Technological University. This was done in two ways: (i) incorporation into the teaching of core-courses as a key element of mechatronic systems engineering and (ii) inclusion in a new-type of research oriented elective course. Inverse dynamics is consistently presented in the following core-courses listed here as a way of teaching fundamentals and considering applications:

- MSE6113 Analytical and Adaptive Dynamics in Mechatronic Systems;
- MSE6123 Mechanical Design of Mechatronic Systems/Robots;
- MSE6143 Adaptive Control in Mechatronic Systems;



- MSE6153 Optimisation in Mechatronic Systems;
- MSE6173 Mechatronic Systems Implementation – I.

Students learn the general fundamentals of inverse dynamics and its connections with the adaptive dynamics of mechatronic systems in MSE6113, the topics for which are shown in Table 12.3. In the course, they also consider general applications of inverse dynamics starting with a particle and going to a system. Some vehicle applications are included. It therefore follows that the MSE6113 course differs from general engineering analytical dynamics courses both by the composition of the addressed topics and the sequence of their presentation.

**Table 12.3** Course MSE6113 – Analytical and Adaptive Dynamics in Mechatronic Systems

Major Topics
Introduction to Mechatronic Systems Engineering
Introductory Lecture In LabVIEW: Dynamics and Control Architecture
Defining Motion. Kinematic Parameters
Constrained Motion. Kinematic Parameters
Direct and Inverse Kinematics
Direct and Inverse Kinematics with LabVIEW
Dynamic Parameters and Characteristics of Motion
Differential Equations of Motion
Inverse Dynamics with Applications
Stability of Mechatronic Systems
Stability of Mechatronic Systems in LabVIEW (PC Workshop)
Dynamics of Variable Mass Bodies and Fundamentals of Adaptive Dynamics

It is precisely this suggested composition of topics and the sequence of their presentation that determine the product orientation of this course since the sequence of presentation in this course is actually an innovative algorithmic sequence of an engineer's actions when synthesising a mathematical model of the mechatronic system under design. It should be emphasised here that the innovation in this algorithm precisely consists of modelling of mechatronic systems on the basis of inverse dynamics principles. The use of these principles makes it possible by means of mathematical modelling to determine the parameters of the system that would provide the system with the required programmable motion, the kinematic features of which were synthesised previously in this course when analysing the topic of inverse dynamics.

Adaptive dynamics is also a new and non-traditional part of the MSE6113 course that originally derives from understanding the laws and causes of learning in animals and man [42] and then goes to non-linear systems behaviour learning [43]. The topic of inverse dynamics is developed further in the parallel Module 1 course MSE6123, Mechanical Design of Mechatronic Systems/Robots. The first part of this course is concerned with vehicle operational properties and vehicle dynamics/performance analysis in conjunction with vehicle mechatronic system

design for both autonomous and conventional ground vehicles, and presents criteria for vehicle performance optimisation and vehicle system design. The second part of the course then considers mechanical engineering problems in industrial robots.

The MSE6143 and MSE6153 courses then consider controller developments based on modelling system inverse dynamics and performance. Finally, the MSE6173 course integrates the inverse approach with vehicle mechatronic system design, including intelligent systems of unmanned vehicles, active suspension, hybrid vehicles and so forth.

The application of the inverse dynamics approach is developed further in elective courses. For example, the new MSE6283 course, Autonomous Wheel Power Management Systems, covers systems that autonomously control power distribution between the drive wheels of a multi-wheel drive ground vehicle. These systems are present in various configurations involved with torque/power vectoring devices and individual wheel control, limited slip differentials, hydraulically controlled differentials and electronically-locking differentials. Autonomous wheel power management systems integrated with other vehicle autonomous systems are also presented in the course.

Students consider the mechanical design of mechatronic systems, methods for developing control algorithms based on inverse dynamics principles and PLD implementation. Methods for experimental study of wheel power management systems and vehicles are also considered.

Students exercise analytical skills and gain hands-on experience through workshops, innovative homework and labs using the 4×4 Vehicle Chassis Dynamometer and associated systems of Figure 12.4. Designed and constructed by the Department of Mechanical Engineering together with Mustang Dynamometer, this is one of the most significant components of the MSE6283 Autonomous Wheel Power Management Systems course and the associated research activity.



**Fig. 12.4** The 4×4 Vehicle Chassis Dynamometer with individual wheel control

This dynamometer is a unique resource for vehicle mechatronic systems experiments and tests whilst each of the wheels can be individually controlled to imitate different road and terrain conditions. The forces, speeds, and power applied to the wheels are all controllable. Random wheel torques in various conditions can be programmed and applied to the wheels. This is done for vehicle performance optimisation and control as well for powertrain and driveline systems experimental research and tests.

The course MSE6233, Special Topics in Mechatronic Systems Engineering – Inverse Wheel Dynamics, is a good example of a new type of course, termed here as being research-oriented. The uniqueness of the course is that this is not a conventional teaching course based on lectures and workshops or projects and labs with predetermined results. Instead, it is a research-oriented course that includes elements of scientific research, e.g., literature search and analysis, formulation of research goals, modelling and computer simulation for achieving the goals [40, 41]. As an outcome of the course, a research paper written with an MSMSE student was recently published by the Mechatronics Forum [44].

## Laboratories

The new Mechatronic Systems laboratory was constructed as a platform both for teaching the MSMSE courses and undertaking research projects for both industry and Government research agencies and organisations with active students' participation. The laboratory also supports student thesis work and experimental research. One of the specific features of the laboratory is the fact that it has been equipped with equipment currently used in the industry for designing mechatronic systems and for advanced mechatronics research. Table 12.4 lists some of the software and hardware that are actively used in the laboratory to support learning and research.

**Table 12.4** Laboratory of Mechatronic Systems: hardware and software list

Mechanical Simulation	CarSim*
Daimler	Mercedes-Benz seven speed automatic transmission
dSPACE	Six PC and six DS1104 R&D Controller Boards
FESTO	2D-positioning system; pneumatic control unit; hydraulic control unit
Kistler Instrument	Two piezoelectric wheel transducers and a control unit; Torque, force, pressure sensors and accelerometers; Multi-component force plate sensor and BioWare software
KUKA Robotics	Two robots KR3
MathWorks	MATLAB and Simulink
MSC.Software	MSC.ADAMS
National Instruments	Six cRIO-9004/NI, cRIO-9104 LabVIEW FDS Bundles; PXI1010 real-time data acquisition system

Programming and commercial software support is very important in mechatronics and many high quality commercial computer products and systems are available. MATLAB and Simulink were selected to support LTU's programme due to their widespread use in industry, and are an integral part of the courses in the MSMSE programme. There is also other software available for control algorithm development and rapid control prototyping, robotic system simulations and programming. Obviously, there is limited time available to teach this range of software as a single course in the programme. A different approach has been developed which incorporates commercial software into the programme at appropriate stages.

The proposed methodology in teaching software is therefore not based on teaching the software products themselves, but on (i) using software for mechatronic system simulations and demonstrations during regular lectures, (ii) providing skills through laboratory and home work, computer workshops and projects on particular engineering problems and also (iii) based on a gradual integration of the software in the programme's courses, not only in one course. As an example, LabVIEW software and related hardware products from National Instruments (NI) Corp. are being incorporated in the MSMSE programme with almost 40 contact hours of lectures, laboratories, workshops, and projects. Thus, when taking the first course in the programme, MSE6113, Analytical and Adaptive Dynamics, students learn the principles of LabVIEW, are familiarised with demonstration models and carry out two 2½ hour workshops on the course topics. The course MSE6143, Adaptive Control in Mechatronic Systems, is then based on projects carried out by students using this software and hardware. At the completion of the programme, the students acquire knowledge in LabVIEW, real-time and FPGA programming skills at an expert level.

MSMSE programme students also participate in research that is carried out at the Laboratory of Mechatronic Systems, including in the fields of:

- mechatronic systems for the distribution of power between the wheels of multi-wheel drive vehicles;
- smart sensors for the pro-active determination of wheel slip under different terrain conditions;
- autonomous vehicle dynamics control;
- pressure centre control and vehicle stability improvement and related topics.<sup>17</sup>

### **Industrial Advisory Board**

The Industry Advisory Board was formed in the earlier stages of the MSMSE programme development. The main goals of inviting companies, Government research agencies and professional organisations to participate are to:

---

<sup>17</sup> See also Chapter 6 – *Mechatronics and the Motor Car*, for more discussion of vehicle mechatronic systems

- advise on the curricular and course development;
- advise and assist in laboratory development;
- assist in the programme assessment;
- provide input on the needs of the industry with respect to this programme;
- assist in promoting this programme in their organisations;
- recommend potential research topics.

Through participation in the Industry Advisory Board, companies and organisations could benefit by:

- early access to new developments in technology with potential applications in new products;
- deeper understanding of current knowledge and resolution of some difficult technical problems;
- educating engineers in this knowledge with a broader base;
- conducting research on specific projects as required;
- receiving innovative solutions to recurring problems;
- access to multidiscipline faculty expertise;
- development and delivery of short courses on specific topics;
- access to the database in applied research;
- hiring future engineers from a skilled pool of highly educated students;
- exposure to students in the programme and company presentations of new products.

The current board is composed of engineers, executives and other professionals working in the industry and professional societies. Members of the board are selected because of their knowledge of business practices, their experience working with engineers, and in the case of alumni, their special knowledge of the culture of Lawrence Technological University. It is also important to maintain a balance between mechatronic product manufacturing companies and companies supplying software tools and hardware instrumentations for product development. Members from professional organisations are very supportive in integrating the MSMSE programme into the professional world of engineering. Members of the Industry Advisory Board include at the time of writing:

Aisin World Corporation of America	MSC.Software
Chrysler	National Instruments
Daimler AG	Opal-RT Technologies
dSPACE	Robert Bosch
Eaton	Robotic Industries Association
FESTO	The MathWorks
Ford Motor Company	The Timken
General Motors	Toyota Technical Center, U.S.A.
Johnson Controls	Siemens VDO

Kistler Instrument

US Army RDECOM  
(TARDEC, Intelligent Systems)

KUKA Robotics

Vector CANtech

Admission to the programme is competitive. Applicants with strong analytical and creative engineering skills must:

- hold a Bachelor of Science degree in Mechanical Engineering, Electrical and Computer Engineering, or an equivalent degree from a college or university accredited by ABET. Individuals with a bachelor of science in mathematics or computer science, or an equivalent degree from an accredited college or university, and three to five years of experience working in mechatronic engineering fields may apply;
- have a minimum undergraduate overall GPA of 3.00.

### **Student Profile**

The diversity of the MSMSE programme and of the student population provides professional growth and competitive advantages for stable employment opportunities in current and future job markets. The ages of the student population ranges from under 30 to over 50. All students are practicing engineering with a range of graduate and undergraduate degrees, including one student who holds a Ph.D. in materials sciences.

## **12.3 Summary**

Mechatronic systems engineers combine sets of engineering skills, bridging mechanical and electronic/computer engineering and are attractive to employers because they are so versatile. Approximately 25% of current MSMSE students have been promoted or obtained better jobs since the programme was initiated in September 2006.

There exists a further positive effect of developing the MSMSE programme in that its development inspired the formation of a new required undergraduate course entitled Introduction to Mechatronics. This is a four-credit course and was worked out and included into the curriculum of the BS in Mechanical Engineering programme. Undergraduate students, in addition to lecture material, have the opportunity to carry out laboratory work in the Laboratory of Mechatronic Systems and to participate in research projects.

The way the MSMSE programme was designed provides high-level expertise and skills for a stable and extended professional career. Emerging research trends in biomechanics and chemistry, bio-materials and biology in general will bring new horizons in mechatronic systems engineering. For this reason, an educational system in mechatronics should closely and comprehensively react to changes in

the field of design of mechatronic systems and, to the extent possible, act proactively, developing new courses and programmes.

## References

1. Ebert – Uphoff I, Gardner JF, Murray WR, Perez R (2000) Preparing for the Next Century: The State of Mechatronics Education, *IEEE/ASME Transactions on Mechatronics*, **5** (2); 226–227
2. Brown NJ, Brown OT (2002) Mechatronics, a graduate perspective, *Mechatronics*, **12**; 159–167
3. Grimheden M, Hanson M (2005) Mechatronics – the evolution of an academic discipline in engineering education, *Mechatronics*, **15**; 179–192
4. Trumper DL, Ludwick SJ (1999) Developments of 2.737 Mechatronics at MIT, *Proc. IEEE/ASME Int. Conf. Advanced Intelligent Mechatronics*, Atlanta; 446–451
5. Graig K (1999) Mechatronics at Rensselaer: A two-course senior-elective sequence in mechanical engineering, *Proc. IEEE/ASME Int. Conf. Advanced Intelligent Mechatronics*, Atlanta; 452–458.
6. Bergh CF, Kita A, Ume IC (1999) Development of mechatronics course in the school of mechanical engineering in Georgia Tech, *Proc. IEEE/ASME Int. Conf. Advanced Intelligent Mechatronics*, Atlanta; 459–465
7. Lima M, Gomes MP, Putnik G, Silva S, Monteiro J, Couto C (2002) Mechatronics education at the University of Minho: a summary of the present; perspective for the future, *Mechatronics*, **12**; 295–302
8. Akpınar B (2006) “Mechatronics education in Turkey, *Mechatronics*, **16**; 185–192
9. Hargrove JB (2002) Curriculum, equipment and student project outcomes for mechatronics education in the core mechanical engineering program at Kettering University, *Mechatronics*, **12**; 343–356
10. Furman BJ, Hayward GP (2002) Asynchronous hands-on experiments for mechatronics education, *Mechatronics*, **12**; 251–260
11. Shetty D, Kolk RA (1997) *Mechatronics systems design*, PWS Publishing Company
12. Poduraev JV (2007) *Mechatronics: fundamentals, methods, application*, 2nd Edition, Moscow, Mashinostroenie Publishing House
13. [www.mechatronics-net.de/?part=main&site=MechatronicPages&where=american](http://www.mechatronics-net.de/?part=main&site=MechatronicPages&where=american)
14. Giurgitiu V, Lyshevski SE (2003) *Micromechatronics, modeling, analysis and design with MATLAB*, CRC Press
15. Cho H, Kim MY (2005) Optomechatronic technology: the characteristics and perspectives, *IEEE Trans. Industrial Electronics*, **52** (4); 932–943
16. Browne AL, Bucknor NK, Cheng YT, Johnson NL, Lin WC, Namuduri CS, Sun Z, Usoro PB (2004) Mechatronics: an automotive perspective, *Proc. SPIE – Smart Structures and Materials*, **5388**, 313–319
17. Craig K (2003) The role of computers in mechatronics, *Computing in Science and Engineering*, March/April; 80–85
18. Bishop RH (Ed) (2002) *The mechatronics handbook*, CRC Press
19. Rivin EI (1988) *Mechanical design of robots*, McGraw-Hill
20. Kenjo T (2001) Developing educational software for mechatronics simulation, *IEEE Trans. Education*, **44** (2)
21. Strategic Five-Year State Workforce Investment Plan, State of Michigan
22. de Silva CW (2005) *Mechatronics, an integrated approach*, CRC Press
23. Craig K (2001) Is anything really new in mechatronics education?, *IEEE Robotics & Automation Magazine*, June; 12–19

24. Newton I (1962) *Mathematical principles of natural philosophy* – Vol. 1, University of California Press
25. Vatul'yan AO (2007) *Inverse problems in mechanics of deformable body*, Fizmatlit, Moscow
26. Aster RC, Borchers D, Thurber CH (2005) *Parameter estimation and inverse problems*, Elsevier Academic Press
27. Yu TV (2005) *Introduction to statistical theory of inverse problems*, Fizmatlit, Moscow
28. Krut'ko PD (1989) *Inverse problems of control systems dynamics: nonlinear models*, Nauka Phys & Math Publishers, Moscow
29. Ceccarelli M (2004) *Fundamentals of mechanics of robotic manipulators*, Kluwer Academic Publishers
30. Spong MW, Vidyasagar M (1989) *Robot dynamics and control*, John Wiley & Sons
31. Wong JY (2001) *Theory of ground vehicles*, 3rd Ed., John Wiley
32. Pirkovsky YV, Shukhman SB (2001) *Theory of motion of multi-drive automobile*, UNITY and ELIT Publishers, Moscow
33. Smirnov GA (1990) *Theory of motion of ground vehicles*, Mashinostroenie, Moscow
34. Gillespie TD (1999) *Fundamentals of vehicle dynamics*, SAE
35. Vantsevich VV (1992) *Synthesis of driveline systems for multi-wheel drive vehicles*, DSc. Dissertation in Automotive Engineering awarded by the Higher Awarding Committee of the Russian Federation
36. Vantsevich VV (2004) *Mathematical fundamentals for vehicle performance control*, Global Powertrain Congress ; 60–63
37. Vantsevich VV, Amani L (2001) *Control of the vehicle's running abilities is a precondition for designing wheel drive systems*, ASME Annual Congress, IMECE/DE-23266, New York, November 11–16, 2001
38. Vantsevich VV (2001) *Vehicle dynamics as the second dynamics problem*, Int. Journal of Vehicle Design, **25** (3) ; 164–169
39. Vantsevich VV, Vysotski MS, Kharytonchyk SV (1998) *Control of wheel dynamics*, SAE Annual Congress, Detroit, Paper #980242
40. Vantsevich VV (2006) *All-wheel drive mechatronic systems: principle of wheel power management*, SAE Annual Congress, Detroit, Paper #2006-01-0580
41. Vantsevich VV (2006) *Inverse wheel dynamics*, IMECE2006-13787, ASME Congress, Chicago,
42. Staddon JER (2001) *Adaptive Dynamics. The theoretical analysis of behaviour*, The MIT Press
43. Tertychny-Dauri VY (1998) *Adaptive mechanics*, Fizmatlit Publishing Company, Moscow
44. Vantsevich VV, Henke S (2008) *Modeling and Simulation of Direct/Inverse Dynamics of a Wheel*, 11th Mechatronics Forum-Conference, Limerick



# Chapter 13

## Mechatronics Education

Job van Amerongen<sup>1</sup>

### 13.1 Introduction

A search of the internet for ‘mechatronics education’ yields many hits with information on many forms of academic mechatronic programmes. They range from BSc to MSc programmes as well as integrated four or five-year programmes. Sometimes, there is a clear philosophy behind this choice, but often it is based on the local culture or possibilities. Several mechatronic programmes seem to be based on simply adding courses on electronics, PLCs and logic circuits to an existing ME curriculum.

However, mechatronics is more than just ‘a controlled mechanical system’. Mechatronic design is:

the integrated and optimal design of a mechanical system and its embedded control system where solutions are sought that cross the borders of the different domains.

An integrated view on the system as a whole is needed in order to come to such a design. In addition to knowledge of the different components, a system overview offered by a proper interdisciplinary model of the system is essential. The curriculum should explicitly pay attention to this.

Real mechatronic systems lead to out-of-the-box thinking and completely new products which could have not been realised in a single domain. The optical disc, for instance, achieved its superior performance, among others, by replacing the need for accurate speed control by an electronics-based clock. This was a revolutionary new approach which resulted in superior sounds. Without its embedded stabilising controller, a device like the Segway [1] would be useless. But with this controller, it is not only stable: a superior manoeuvrability is achieved in comparison to a mechanically stable device with more than two wheels. Any real mechatronics programme should be based on a philosophy of obtaining synergy by an optimal combination of mechanics, electronics and information technology.

---

<sup>1</sup> University of Twente, Netherlands

In this chapter, several forms of mechatronic programmes in curricula of the University of Twente of the past 20 years are discussed. Many students have been educated in different forms of educational programmes [2]. Changes in programmes were often triggered by changes in the structure of university education, nationwide or across Europe, e.g., all universities in the EU have, for a number of years, been expected to offer academic education in the form of BSc and MSc programmes.

## 13.2 Historical Context

The University of Twente has been explicitly active in the field of mechatronics since 1989. In 1989, after obtaining 1.25 M Euros of extra funding from the Ministry of Education, five groups in the faculties of Electrical Engineering, Mechanical Engineering, Applied Mathematics and Computer Science started their cooperation in the Mechatronics Research Centre Twente (MRCT). Cooperation between people from different disciplines is not always obvious, but at the University of Twente, it was relatively easy. The university was founded in 1964 and in the beginning, all departments shared a common first year that provided a broad-based programme to all engineering students. Even after this common first year was abandoned, it was good practice to have a representative of another department in the committee that guided and finally judged the thesis work of students.

This close cooperation between staff members of the various faculties led to a good knowledge and understanding of each other's activities and a lot of interaction. This cooperation has been the basis for many multi and interdisciplinary research activities, now concentrated in a number of research institutes. In order to achieve real cooperation, good personal relations are crucial. In the early years of the MRCT, the group leaders of the different participating groups visited Japan and the USA to see the state of the art in mechatronics in those countries.

In addition to attending conferences, visits to mechatronic industries and universities were made. These visits not only provided a good overview of the state of the art of mechatronic-like activities in Japan and the USA, but travelling as a group for four weeks in total contributed significantly to solidifying a team of the members from the different departments.



**Fig. 13.1** The MART robot

In order to learn what mechatronics was all about, the MRCT used a major part of the extra funding in 1990 to start a large research project, the MART project, involving four Ph.D. students and many MSc projects. The idea was to build an advanced mobile robot that should be able to gather components from part-supply stations and assemble these components while driving around in a factory (Figure 13.1).

Apart from the aspect of being an attractive solution for flexibly building many variants of a product or a variety of products, the goal of this project was to learn and demonstrate a mechatronics approach in an interdisciplinary project. At about the same time, a part-time professor in mechatronics was appointed for two days a week in the Faculties of Electrical and Mechanical Engineering. This individual had a lot of experience with mechatronic applications in industry, where he continued to be active the rest of his time. In the university, one of his major roles was as the project leader of the MART project. Over a period of about five years, four Ph.D. and approximately 50 MSc students did their thesis work on this project with students from electrical engineering, mechanical engineering and computer science working together in one project room. This alone has contributed to students with a basic education in their own field learning the language from other disciplines and understanding how to work together in a project with a clear systems approach. This means realising that not only the best solution for an isolated problem could be sought, but that the consequences for other parts of the design and for the system as a whole had to be taken into account at all times.

As a result, the mobile robot was completely realised [3]. It had many advanced features in the field of mechanical constructions and control such as an adaptive preload system to reduce friction and backlash [4], learning control [5], parallel computing, autonomous navigation [6, 7] and so forth. More information about the

project can be found in Van Amerongen and Koster [8] and in a video available at the project web site [9].

For many of the students working in this project, it was the start of a career in mechatronics. In fact, one of the Ph.D. students started a successful mechatronic company and states that a large part of his network in the mechatronic community in the Netherlands consists of students and colleagues who were active in the MART project.

Curriculum developments are often a result of changes in educational systems or funding sources. Since the start of its mechatronics activities in 1989, the University of Twente has offered mechatronics education in the MSc programmes of EE and ME, and for several years in the two-year post graduate ‘Mechatronic Designer’ programme. Since 2001, the University of Twente has also offered a two-year international MSc program in Mechatronics. In the same year, the university transformed its study programmes to the new European BSc/MSc structure, including an English language MSc in Mechatronics. In September 2004, the international MSc programme merged with the Mechatronics MSc programme.

The mechatronics activities of the University of Twente now range from education in the new BSc/MSc structure, to research activities in Ph.D. projects. In addition, there have been a number of projects that aim to support industry in developing mechatronic skills or in producing advanced mechatronic systems by means of knowledge transfer. One of these was the Mechatronics Innovation Center, subsidised by the Interreg III programme of the EU and intended to transfer knowledge from the university and a Fachhochschule in Germany to small and medium sized enterprises in the border region (Euregio) of the Netherlands and Germany.

It is believed that mechatronics, dealing with:

the integrated and optimal design of a mechanical system and its embedded control system

can only be performed well in an environment where mechanical and electrical engineering and information technology are combined in a synergistic cooperation. Section 13.3 goes into further detail on the educational activities.

### 13.3 Curriculum

There are several possibilities and examples of mechatronics programmes. The simplest option is to add elements from other disciplines into existing EE or ME programmes. Often, these elements are already there. However, they can be made explicit by means of a project where some mechanical structure has to be built and controlled by a computer-based control system. A modern ME programme simply needs to contain elements of electronics and computer-based control anyhow. Many universities have this type of project, and they are highly appreciated by the

students because it is fun to work on such projects. Mechatronic projects can be included in a BSc programme. MSc programmes in EE and ME which are flexible enough with respect to the elective courses that can be chosen by the students also allow for a lot of mechatronic content. Though unless there is some pre-structuring of these electives, there is no guarantee that a well balanced programme is the result. Also, the required basic knowledge necessary for successfully following advanced courses may be missing. Therefore, a real mechatronics programme is desirable.

The other obvious thing to do is Ph.D. projects of a mechatronic nature. During a Ph.D. project, there is ample time to work on an interdisciplinary project. Finally, specific BSc, MSc or combined BSc and MSc programmes in Mechatronics can be designed.

It is hardly possible to say if there is a preference for a BSc, MSc or integrated BSc-MSc programme in mechatronics. A choice is often influenced by local circumstances and regulations. It is a choice between a broad multidisciplinary basic education and specialisation at the end or a more mono-disciplinary basic education followed by a broader scope at the end. One thing is clear, however, a mechatronic designer should have a wider and, consequently, shallower scope of knowledge than a specialist studying in a mono-discipline (Figure 13.2).

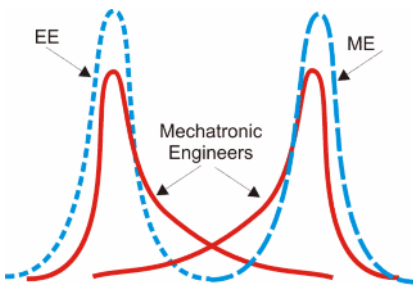

**Fig. 13.2** Mechatronic Engineers lack some depth in their ‘original’ discipline, but have broader knowledge of other disciplines

### ***13.3.1 Mechatronic Designer Programme***

During the 1980s, the Dutch government decided that it should be possible to complete an MSc degree within four years (instead of five), also in the technical disciplines. This was intended to be a final degree for 60% of the students. The other 40% were supposed to continue their education in a four-year Ph.D. programme or in a two-year Technical Designer programme. A two-year ‘Mechatronic Designer’ programme was started as a result of these developments. In this programme, the first year was filled with courses to obtain knowledge of the other discipline and deepen the theoretical knowledge, while the second year

was completely devoted to a design project in cooperation with industry. This programme has produced several successful mechatronic designers and led to design results which were actually implemented in industry. Some of these mechatronic designers now successfully run a company.

Of course, the four-plus-two curriculum allowed more time for mechatronic content than the typical three-plus-two BSc-MSc sequence. After a few years, due to pressure from the technical universities, the five-year programme came back again. For students, this meant that the two extra years of the designer programme lost a lot of their attractiveness. This signalled the end of the Mechatronic Designer programme at the University of Twente, although it was continued at Eindhoven University of Technology for some time. Mechatronic education continued as a specialisation in the MSc programmes of the faculties of EE and ME.

### ***13.3.2 BSc Curriculum***

A BSc curriculum either in EE or ME offers ample opportunities to pay attention to the mechatronics design approach. Such an example of a systems approach is attractive for all EE and ME students, even if they continue their study in other topics. The EE curriculum at the University of Twente offers a broad education in all aspects of electrical engineering and contains, among others, courses in mathematics, physics, electrical networks, electronics, electrical power engineering, linear systems, modelling and control. In each semester, a number of closely related courses are offered.

When electrical networks are taught, this is closely related with those courses in mathematics needed to properly teach electrical networks. In a similar way, courses on mechanics, transduction technology, measurements and instrumentation, linear systems, dynamical systems and control engineering are programmed closely together in the second half of the first semester, and in the first half of the second semester in the second year. This series of courses is concluded with a two-week ‘mechatronics project’ that integrates the theoretical knowledge taught during the courses. The project is supervised by the lecturers of the different courses, aided by Ph.D. students and student assistants.

Before going into detail on the project itself, consider the content of dynamical systems and control engineering courses. In the course on dynamical systems, students learn to analyse and model physical systems in various domains. Emphasis is on electrical and mechanical systems. By using a port-based approach, modelling in various domains is relatively easy and the relation with the physical reality is maintained and not hidden by abstracting the models to block-diagram-based input-output models.

This modelling approach is supported by the 20-sim software package (see Section 13.4) and builds on previous courses on linear systems, electrical networks, electromagnetism and mechanics. It forms a link between the more

physical-oriented approach of the courses on electromagnetism and mechanics, and the more mathematical and signal-oriented courses in electrical networks and linear systems. The course in control engineering is closely integrated with the modelling course and uses mechatronic systems as examples of the basic theory (stability, root loci, bode, nyquist, state space, non-linear systems and introductory digital control).

The planning of the mechatronics project is as follows. At day one of the project, teams of four students get a transducer in the form of, e.g., a motor, piezo element, loudspeaker, voice coil etc. Often, these transducers can be used as an actuator and a sensor as well. Over three days, this transducer should be properly described by analysing its operation principles and by measuring its relevant properties; integration of knowledge from the courses on mechanics and transduction techniques, measurement and instrumentation and dynamical systems. Because of its application later on in the project, the dynamics of the transducer should get special attention.

A well-equipped lab is available to the students (Figure 13.3). Each team gets a lab space and a set of equipment consisting of a PC with software such as LabVIEW and 20-sim (see Section 13.4), function generators and power supplies, an oscilloscope, and so on. Instructional material regarding planning of the project, datasheets and diagrams for possibly needed electronic circuits, are made available at the project website. Based on the characterisation of the transducer, the team has to make a proposal for a mechatronic system built around the transducer where, in general, a motion has to be controlled. The proposal should be based on an analysis of the dynamical properties of the total system and the possibilities to control its behaviour.

After approval of the design and comments on the proposal by the supervisors, the feasibility phase begins (three days). This includes making a dynamical model, design of one or more (digital) controllers and simulation of the controlled system. Nothing is really being built in this stage of the design, although it is encouraged to investigate the feasibility of the proposed solutions with test set-ups. During the feasibility study, ideas can be discussed with the supervisors of the project. The feasibility phase ends with a written proposal that should clearly demonstrate and motivate why this design will lead to a working mechatronic system. This analysis should be confirmed by a computer simulation of the proposed design in 20-sim.

After approval of the feasibility study, the rest of the second week of the project is spent on building the system and finally giving a short presentation to all the supervisors. For the realisation phase, students have access to basic electronic components and mechanical construction materials. In addition, they get a small budget of 50 Euros to enable them to buy additional parts or materials for their set-up. Care is taken that such parts do not have more than one day delivery. They may also use the mechanical workshop to construct certain mechanical parts they may need. For the realisation phase, empty printed circuit boards for making analogue circuits with operational amplifiers are available as well as a DSP-board for realising the digital controller (Figure 13.4).

This DSP-board can be programmed by automatically generating code from the 20-sim simulation environment and downloading this code from the simulation PC to the processor board [10]. The DSP boards are not hidden in a protective case. The first reason is that the case with connectors would probably be more expensive than a new board, and the second is not to hide the technical content of the board in a 'black box'.

The project ends with a short presentation to all the supervisors on the last day of the project. At the same time, a written report should be ready. All teams are judged based on the quality of the presented design and the written report. Figure 13.3 gives some impressions of the project. A video of some of the set-ups is available as well [11].

Over the years, there have been various forms of the project. In the beginning, students were completely free in the choice of transducers and type of set-ups. This led to a wide variety of set-ups. Later, the transducers were provided and any set-up could be proposed as long as the transducer was used. Recently, all students were asked to construct a 'balancing stick' (say a Segway-type of set-up). All approaches have their advantages and disadvantages. Because there is only limited time for the project (two weeks full time), there is always a tendency to structure the project such that the learning goals, integration of the corresponding courses and coming to a working set-up, are achieved. However, more structuring does not stimulate creativity. There should always be space for creative proposals from students that do not strictly fit into the set boundary conditions.

In the third year of the BSc programme of Mechanical Engineering, there is also a mechatronics project. This project integrates a number of courses from the ME curriculum, such as Applied Electricity, Systems and Control, Measurements in ME and Dynamics. Focus is on the design and realisation of a mechanism with structural flexibilities and computer-based control of this mechanism. Actuators, mechanisms, modal analysis, sensors and control systems are the keywords of this project.





(a)

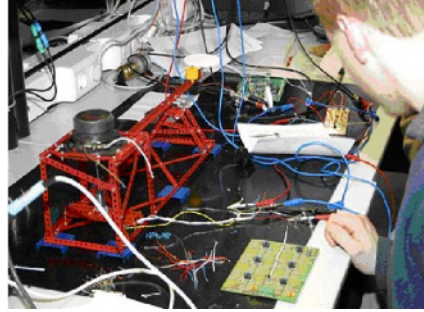

(b)

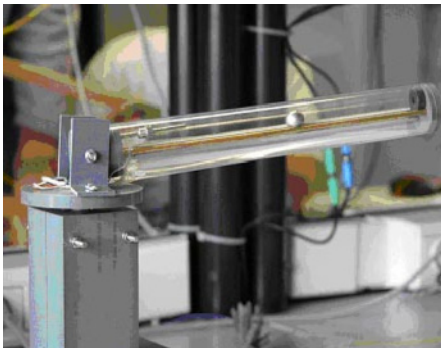

(c)



(d)



(e)

**Fig. 13.3** Impressions of the mechatronics project (a) laboratory, (b) building a set-up, (c) finished design, (d) draft report, and (e) checking of set-up by supervisors

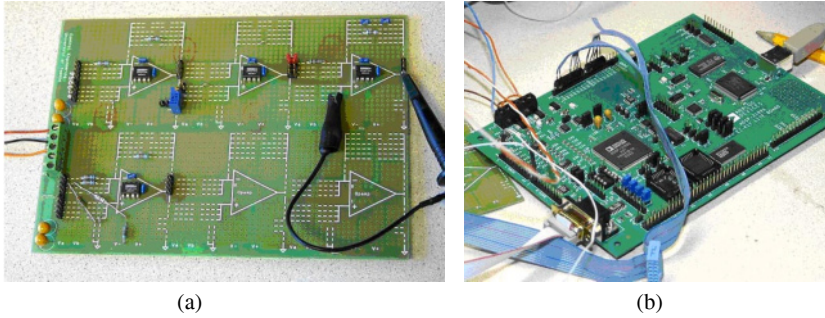

**Fig. 13.4** Analogue board (a) and DSP board (b)

During the 2007 Workshop on Higher Education in Mechatronics at the AIM conference in Zurich, several individuals and universities presented other realisations of mechatronic projects including:

University	Presenter
Politecnico di Milano	Braghin
Stanford University	Carrye
University Of Bergamo, Mondada	Forlani
EFPL Lausanne	Romano
U.S. Naval Postgraduate School	Sieglwart
ETH Zurich	Nelson

In addition, the Mechatronics project work at the University of Loughborough in the UK is well known [12].

### ***13.3.3 MSc Curriculum***

The MSc Mechatronics curriculum is a two year curriculum offered by the departments of EE and ME. It starts with a homologising phase where students with an ME background get courses in electronics and signals and systems, and former EE students get courses in, e.g., mechanical constructions and finite elements, see Figure 13.5, the left two tracks. In the next phase, students follow compulsory courses on Construction Principles, Design of Mechatronic Motion Systems, Digital Control Systems and Measurement Systems for Mechatronics. The list of courses is completed by a number of elective courses. Students from Dutch universities have a compulsory internship in industry, preferably abroad. International students do some extra courses instead; see Figure 13.5, right track. The study is completed by a 25 week MSc project. The programme is open for students from Dutch universities with the appropriate BSc education and, after an admission procedure, to qualified students from abroad. If possible, the

international students are given the chance to do their MSc project in cooperation with industrial partners or in industry. More information on this programme can be found on the internet [13].

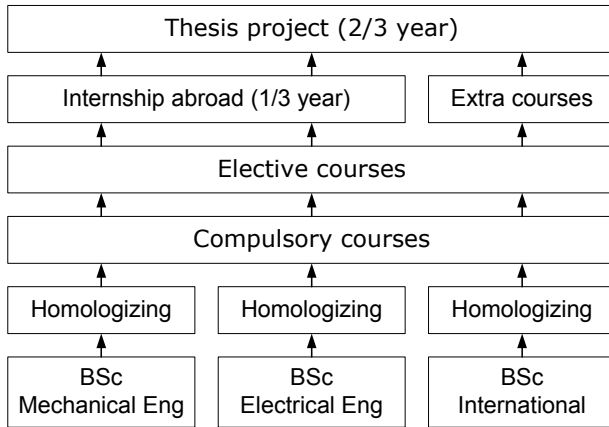

Fig. 13.5 Structure of the Mechatronics MSc curriculum

### 13.4 Modelling of Mechatronic Systems

Modelling and simulation plays a crucial role in mechatronic design and should therefore garner attention in the curriculum. The Control Engineering group of the University of Twente has been a pioneer in modelling software and as a result of these activities, the group developed the simulation program THTSIM in the 1960s that later was used all over the world as TUTSIM. A completely new program became available under the working name CAMAS [14]. It supported a port-based modelling approach (in the form of bond graphs) which is important for modelling physical systems that extend over various domains. It was successfully developed further into a powerful tool for modelling, analysis, simulation and design of mechatronic systems [13, 16]. Since 1995, the program has been commercially available from the company Controllab Products under the new name 20-sim (pronounced: Twente-sim) [17]. It is now widely used in educational institutes and industry. Based on results of ongoing research projects, the program continues to improve and extend with better modelling and simulation algorithms and new functionalities.

Because a mechatronic system involves at least the mechanical and electrical domain, standard modelling packages that work in one domain only are not always useful for mechatronic design. Block-diagram-oriented packages like Matlab and most other simulation packages lack the direct link with the physical reality. Parameters tend to be combinations of the physical parameters of the

underlying model. In addition, models cannot easily be modified or extended. By connecting ideal physical models to each other through power ports, models can be built that are close to the physical world they should describe. This allows that instead of unilateral input-output relations, bilateral relations are described. The model equations are not given as assignment statements, but as real mathematical equations. In addition, a small modification or extension of the model does not require that all the equations that describe the model be derived again. The properties of a component may be changed as long as the interface remains the same. This allows submodels of different complexity to be evaluated and tested (polymorphic modelling). A variety of presentations (multiple views) allows that an appropriate view can be generated for all partners in a mechatronics design team, whether this is an iconic diagram, bond graph, block diagram, control engineering representation, time response or 3D animation.

An important feature of 20-sim is its ability to generate C-code from the models used in the simulator. It is, for instance, possible to generate code of a controller that has been tested in a simulation environment and download the code to some target hardware. By using templates for the specific hardware environment, a flexible solution is offered that enables code generation for a variety of target hardware. An example is the DSP board shown in Figure 13.4. More on the use of this port-based modelling approach for the design of mechatronics systems can be found in Van Amerongen [18] and Van Amerongen and Breedveld [15].

A motor selection wizard has been recently added. It couples a database of commercially available servomotors to the modelling and simulation environment of 20-sim. After specifying the demands with respect to the performance of the controlled system, a motor is proposed to the user. This motor can be further examined with respect to its dynamic behaviour, heat production and so on. An impression of the relevant screens is given in Figures 13.6 and 13.7.

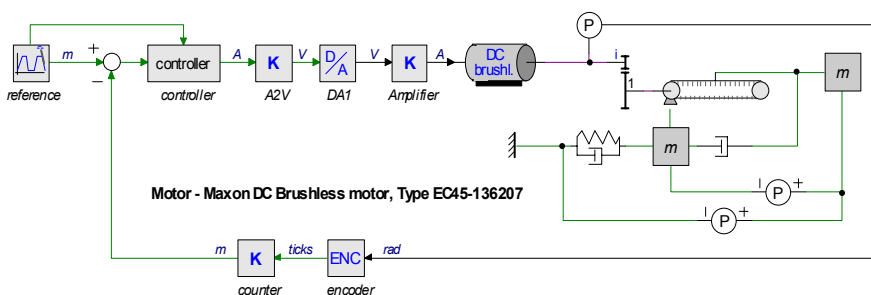

**Fig. 13.6** Model of the mechanical set-up, actuator and controller used to examine the performance of the selected motor

Besides from showing a useful tool for mechatronic design, this example demonstrates the multiple view feature of the software. Time responses, static diagrams, as well as 3D animations reveal different aspects of the system under

investigation and may appeal to other members of the design team. Changes are reflected in all domains simultaneously. This contributes to real mechatronic design.

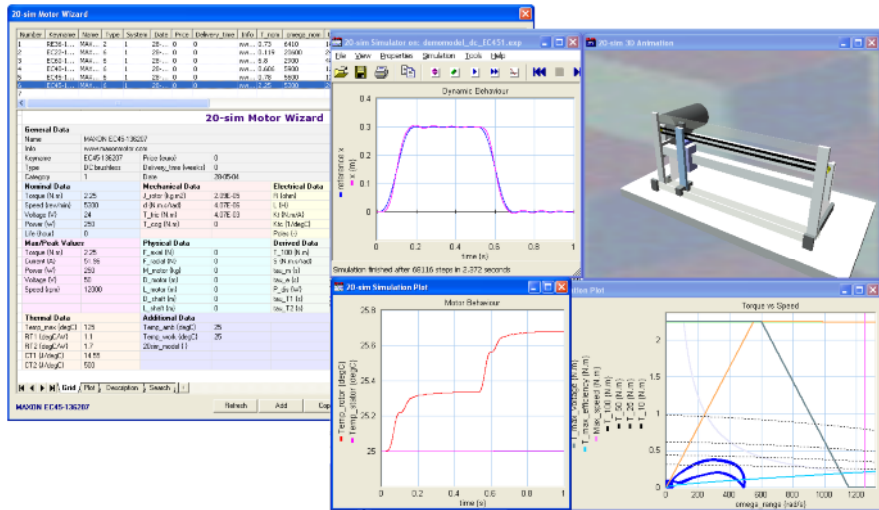

Fig. 13.7 Screen dumps of the motor selection wizard and various screens showing the behaviour of the controlled system, including the temperature change and a 3D animation

### 13.5 Conclusions

This chapter has given an overview of several forms of mechatronic programmes. A general conclusion is that a good basic education in mechanical or electrical engineering followed by a mechatronics curriculum produces mechatronic engineers that have proven to be valuable in industry. Of course, the need from industry depends on the type of industry. In the Netherlands, there are few large players in the area of mechatronics. Companies like Philips (inventor of the CD player) or ASML (world leader in wafer steppers) produce advanced mechatronic equipment. They need specialists and system integrators working in teams. Of course, smaller companies that cannot afford such teams require people with a broader education who are able to deal with mechanical as well as electronic and IT issues.

In all cases, a mechatronics curriculum should pay attention to teaching the languages of the different disciplines. Modelling and the possibility to present the ideas of the modelling process in multiple views is an essential part of this. Essential knowledge that every mechatronic engineer should have is in basic mechanical engineering topics such as:

- construction principles;
- design methods;
- statics and dynamics;
- finite element modelling.

One should also possess a familiarity in topics from electrical engineering including:

- electrical networks;
- signals and systems;
- sensors and actuators;
- digital and analogue electronics;
- embedded signal processing;

and of course in topics such as:

- modelling of dynamical systems;
- control engineering.

In addition, courses which go more into depth in, e.g., optimal or robust control or focus on applications such as biomechatronics as well as non-technical courses may be selected. An important element in mechatronics education should be to let the students work in multidisciplinary teams. This can be done as part of the compulsory courses, as in a ‘mechatronics project’, but should also be present in the individual projects such as a thesis project of sufficient length.

Mechatronics always involves input from disciplines like electrical and mechanical engineering. This not always appears to be easy. At workshops on mechatronic education, people complained about problems with departments that did not allow EE students to select ME courses or *vice versa*. Such problems can be solved by setting up a new mechatronics curriculum. But most important is the attitude of the people involved and the willingness to really cooperate.

Is there a need for ‘mechatronic engineers’? Yes there is. Higher precision, more flexibility and reduction of the cost of mechanical devices and new functionalities can only be achieved by integrating intelligent electronic control systems and embedded computers in the mechanical construction. People trained in systems thinking and able to find solutions that cross the borders of different domains are increasingly essential for making advanced, competitive products.

## References

1. [www.segway.com](http://www.segway.com)
2. Amerongen J van (2004) Mechatronics Education and Research – 15 Years of Experience, Invited plenary paper in 3rd IFAC Symposium on Mechatronic Systems, Sydney: 595–607
3. Schipper DA (2001) Mobile Autonomous Robot Twente – a mechatronics design approach, Ph.D. thesis, University of Twente:155, ISBN 9036516862

4. Kruijer CW (1992) *Geregeld voorspannen van tandwielen*, MSc thesis, University of Twente, Enschede. The Netherlands (in Dutch)
5. Starrenburg JG, van Luene WTC, Oelen W, Amerongen J van (1996) Learning Feed forward Controller for a Mobile Robot Vehicle, *Control Engineering Practice*, **4**(9):1221–1230
6. Oelen W, van Amerongen J (1994) Robust Tracking Control of Two Degrees of Freedom Mobile Robots, *Control Engineering Practice*, **2**(2):333–340
7. de Graaf AJ (1994) *On-line measuring systems for a mobile vehicle and a manipulator gripper*, Ph.D.-Thesis, University of Twente
8. Amerongen J van, Koster MP (1997), *Mechatronics at the University of Twente*, Proc. American Control Conference (AAC), Albuquerque: 2972–2976, ISBN 0-7803-3832-4
9. MART video; [www.ce.utwente.nl/rtweb/files/movies/Mart\\_DivX.avi](http://www.ce.utwente.nl/rtweb/files/movies/Mart_DivX.avi)
10. Jovanovic DS, Orlic B, Broenink J, van Amerongen J (2004) Inexpensive Prototyping Environment for Mechatronic Systems, Proc. WESIC 2003, Miskolc, Hungary
11. Mechatronics project video, [www.ce.utwente.nl/RTweb/files/pictures/Mechatronicsproject\\_2007/video](http://www.ce.utwente.nl/RTweb/files/pictures/Mechatronicsproject_2007/video)
12. Parkin R (2002) A Mechatronics Teaching Module for MEng Students at Loughborough University, Proc. Mechatronics 2002, Twente: 801–809, ISBN 90 365 17664
13. Mechatronics education Twente, [www.ce.utwente.nl/RTweb/education/index.php?body=mechatronics\\_general](http://www.ce.utwente.nl/RTweb/education/index.php?body=mechatronics_general)
14. Broenink JF (1990) *Computer-aided physical-systems modelling and simulation: a bond-graph approach*, University of Twente, Enschede, Netherlands, 207 p, ISBN 90-9003298-3
15. De Vries TJA (1994) *Conceptual design of controlled electro-mechanical systems – a modeling perspective*, University of Twente, Enschede, Netherlands, 169p, ISBN 90-9006876-7
16. Amerongen J van, Breedveld PC (2003), *Modelling of physical systems for the design and control of mechatronic systems*, IFAC Professional Brief, Annual Reviews in Control **27**(87–117), ISBN S1367-5788
17. 20-sim, [www.20sim.com/](http://www.20sim.com/)
18. Amerongen J van (2002) *The Role of Controls in Mechatronics*, The Mechatronics Handbook, Bishop RH (ed), CRC Press: 21.1–21.17, ISBN 08 493 00665

# **Chapter 14**

## **A Personal View of the Early Days of Mechatronics in Relation to Aerospace**

**Bill Scarfe, MBE<sup>1</sup>**

The danger has always been that mechatronics is seen by industry as an academic concept and the aim here is to provide a then practicing engineer's view on the early days of mechatronics from the perspective of the UK aerospace industry. As someone who personally became involved with mechatronics as the concept was itself developing, it was unclear as to where the division lay between the two disciplines of systems and mechatronics. The passage of time did little to improve the situation and within the aerospace industry, there was little interest in mechatronics. In fact, it was seen by many as an irrelevance and a distraction from the key engineering tasks at hand.

What follows is based on the early days of mechatronics when avionics itself was in its infancy. Early aircraft had to be simple, with an emphasis on achieving a weight at which they had the ability to become airborne. With the development of more powerful engines, thoughts turned to the addition of equipment to support pilots in operating the aircraft and to improve passenger as well as pilot comfort. In many cases, these new systems resulted from advances in other engineering fields and were not directly related to aircraft. Instead, as new equipment and technologies emerged, aircraft designers adapted these for aircraft use, and initially, little attention was given to designing systems specifically for aircraft. Indeed, the commercial market was not sufficiently large in and of itself to justify investment on a large scale.

The conditions pertaining in the 1930s and 40s resulted in a significant shift in aircraft systems. Bombers needed navigational aids to arrive at designated targets and to deliver bombs accurately, advanced bombsights such as the gyroscopically stabilised Norden sight used by the USAAF were essential. Developments in radar included the introduction of centimetric systems based on the cavity magnetron and the klystron valve, and these were used in both air-to-air and air-to-ground modes. Aircraft had to fly higher, which resulted in the introduction of pressurised

---

<sup>1</sup> Former Chief Systems Development Engineer BAe, UK



systems. By the late 1940s, systems concepts initially centred on electrical generation, fuel supply and hydraulics were established.

Though aircraft had now become increasingly complex mechanical systems carrying a range of electronics such as radar and radio, it was not until the introduction of the digital computer that a new approach to systems engineering became a priority within the industry. In the case of the then BAC<sup>2</sup>, the first aircraft that made significant use of digital computing was the SEPCAT<sup>3</sup> *Jaguar*, an Anglo-French project, although the French aircraft retained the more conservative analogue system.

The decision to go digital was in this instance an eleventh hour choice by the customer, the UK Ministry of Defence (UK MOD). All preliminary design had been based on analogue computing which meant that work by subcontractors for various sub-assemblies and equipment had also been analogue and would remain so. In 1966, digital computing was very much in its infancy and the chosen on-board computer had a memory of 8.2k!<sup>4</sup> High-level languages did not exist for such computers and to make the exercise viable, machine code was used throughout.

Starting from scratch with no experience and no engineers with knowledge of developing such a complex hybrid analogue/digital system, provided a major challenge. In particular, there was the need to develop the techniques that would provide designers with the confidence that the total package, newly named avionics, could be cleared for flight. Following consideration of the impact of this new discipline, it was decided that because of the multiple interactions involved, the development work had to be undertaken in real-time. The glue between the different equipments was the *digital programme*, another new dimension introduced by avionics.

The newly renamed British Aerospace (BAE) was awarded the contract to supply the weapon system and a means of developing this package was required. A rig was designed and built to ensure that this system performed as intended. This first attempt quickly highlighted shortcomings with the detailed design of the test facility and it was back to the drawing board with lessons duly learnt! During this gestation period, new staff had been acquired with knowledge of digital systems which resulted in a much improved design of ground facility. This rig design became the standard for systems work within the company and was virtually unaltered for at least twenty years. All of the subsequent *Jaguar*, *Tornado* and *Typhoon* projects then used, with some minor changes, this same development rig design.

British Aerospace was the prime contractor responsible to the UK MOD for the design and production of the *Jaguar* airframe, with the systems equipment being

---

<sup>2</sup> The then British Aircraft Corporation, later British Aerospace (BAE) and BAe Systems

<sup>3</sup> Also SEPECAT for *Société Européenne de Production de l'Avion d'École de Combat et d'Appui Tactique*

<sup>4</sup> By comparison, the Apollo Guidance Computer used by the Apollo Moon Lander had 4k of RAM and 32k of ROM.

procured by the customer. The task of managing the interfaces between the equipments of different manufacturers was awarded by the customer to EASAMs, the systems wing of Elliot Automation. As prime contractor, BAE was however still ultimately responsible for delivering a fully operational weapons delivery system, including equipments outside the remit of the EASAM contract.

Because of the lack of previous experience within the aerospace industry of a project of this nature, much thought was given to ensuring that design requirements of the total system were achieved prior to flight. The approach chosen was to extend the individual development rigs to provide a total system.

A very important part of this total system is the pilot and as their operational tolerances cannot be controlled to the same extent as other equipments, of necessity, they must be included as a major part of the system! This also required the cockpit to be spatially correct and the system to operate in real-time, primarily with respect to response times. A simple '*flight stimulation*', was all that was required. Unlike a flight simulator, minor perturbations of an aerodynamic nature were not necessary. The flight simulation programme also had to provide stimulation to all the related equipment so that the loop was closed correctly in real-time for multi-dimensional manoeuvres. In later stages of development, pilots learned to fly the *system* on the rig as opposed to the aerodynamic handling which still remained the province of the flight simulator. The resulting facility was later used to train customer ground and aircrew, demonstrating the flexibility of the design.

This early experience on the test facility enabled the same techniques to be used in research work looking at the directions in which technology was moving. For instance, in the mid-seventies, research into cathode ray technology and the work on flat screens showed the future possibilities of active displays. The technology at that stage was still very much for the next generation, but questions had to be asked as to how it could eventually be utilised on aircraft.

In those early days, a key problem with using CRT displays was the extremes of ambient lighting encountered during flight. To make reliable use of colour requires the ability to maintain colour integrity under all lighting conditions from total dark, to full sun above the clouds, a very severe regime. Not only did systems have to be developed, but a means of achieving the development also had to be thought through. In the case of colour displays, a lighting facility was required to accurately recreate the conditions to be encountered in flight. A whole book could be written on this topic alone! The facility created to develop the displays for the *Typhoon* required a megawatt of lighting to achieve an accurate representation of the light levels encountered above clouds and in bright sunlight. Imagine the cooling required to protect the pilot from cooking!

This early work quickly highlighted the fact that for future projects to be viable, delivery times to the customer had to be reduced. Exacerbating this problem was the speed at which new technology was maturing. Even in the early days, projects were being supplied to customers with out of date technology, understandably not something customers were pleased with. This created a further problem for the customer who felt they were being overcharged. The UK MOD

considered that fixed price contracts should be the ambition and worked hard to reach this end. This was achieved on the *Typhoon* project, but there was not a complete understanding of the full implications of such contracts.

The delivery cycle of an aircraft order extends over many years, during which time technology will have seen many major advancements with new and better devices available. To change the design parameters in order to take advantage of these improvements requires negotiating a new contract. A fixed price contract protects both purchaser and supplier!

As prime contractors, it was not possible to start integrating all the systems until the majority of such equipments were available. Because of the complexity of aircraft systems, it is inevitable that although equipment may perform to specification in isolation, problems could, and often do, arise when integrated with other equipment. This was more the norm than an exception, causing costly modifications and slips to the delivery programme, resulting in serious cost implications.

This was clearly a priority area to be addressed: how to speed up the process of equipment specification and procurement? The first approach was to make our own equipment using cheap and simple components. This worked to a limited extent, but it was obvious that a much quicker method was needed. However, digital simulation and modelling was difficult at the time, mainly due to a lack of suitable graphic waveform generators.

To that end, a joint study was undertaken with a computer company to develop a suitable device to facilitate the production of virtual equipment. This joint effort proved successful and with the new graphics systems that were also becoming available, the first virtual (equipments) image quickly followed. This technique became known as rapid prototyping and enabled new ideas to be tried quickly and cheaply. As an aside, it was also the development that enabled computer games to be commercially produced.

With the availability of advanced simulators and the use of modelling techniques, dynamic real-time investigations became a reality. Now, instead of providing manufacturers with a written brief, it became possible to show physical shape and to demonstrate operation in real-time. This much reduced the time required to produce operational equipment<sup>5</sup>. Thus, a solution was available to eliminate the often seemingly endless iterations to achieve a robust and satisfactory design. Indeed, the system was developed to the point where it was possible to generate a whole suite of functioning interactive equipment.

By this means, designers, pilots and equipment manufacturers could all quickly explore new ideas. The input of the aircrew was now based on actual 'flying' experience and when a difficulty was encountered, modifications were possible with the user very much involved in the process. This occurred well in advance of any design freeze and long before flight trials were possible.

---

<sup>5</sup> Essentially a *hardware-in-the-loop* approach linking a real-time functional simulation to real hardware

From the systems experience and the confidence gained, a new approach to the design process evolved, top-down design across all systems. It was at this point that the essence of mechatronics came into play, although it was not seen as such. There was a reluctance to embrace what was seen as a discipline in name only, and there was a difficulty in accepting that what the aviation industry was involved with was anything other than systems engineering.

Personal early experiences did nothing to allay that feeling. All mechatronics meetings could be guaranteed to commence with a debate on the latest thoughts on the subject! It is interesting that Google, on being asked for information on the subject, asks the question, “*Did I mean macaroni?*”. The Experimental Aircraft Programme (EAP), the forerunner to the *Typhoon*, was the first occasion where from personal experience the various mechanical and electronic systems were viewed as an entity where common software and computing modules were shared. This approach enabled a true top-down design to be implemented. For the first time, the aircraft was treated as a whole, with the interactions between all systems being considered.

To aid understanding, consider a typical situation where the aircraft is coming in to land and the pilot selects ‘*undercarriage down*’. Consider what is involved. Prior to the selection of ‘*undercarriage down*’, the aircraft is in a clean configuration with the relevant flight programme engaged. As the landing gear comes down, there is a considerable change in the aerodynamics and a corresponding change in handling characteristics. In the past, this required the pilot to manually change the trim at a particularly busy time in the flight. With the new approach, the selection of ‘*undercarriage down*’ not only deployed the undercarriage, but also selected a matching aerodynamic programme, much reducing the pilot workload!

Through this holistic approach, the role of the pilot was now able to be reassessed. Much of the routine housekeeping could now be left to the system with the pilots’ role focussed on doing what humans are best at, creative thinking. Artificial intelligence has since come a long way and much of routine flying can now be safely left to the system.

Other developments which have taken place in recent years, such as intelligent skins and structures, were always considered a possibility as were such things as eyeball and neural control, all of which could certainly be considered as being mechatronic. There is, however, a time lag between the development of concepts such as these and the availability of technologies capable of implementing them.

Part of the task at BAe Systems is that of being aware of the research being undertaken in academic institutes, especially ‘Blue Skies’ research. Part of that responsibility is to establish contacts at universities, to be aware of developments and what they might offer in the future. This is by no means a one way exercise and both sides benefit from the relationships so formed!

At a personal level, it has been my long held belief that in military systems, the pilot or operator would be better placed on the ground than in the machine as they are more valuable than a machine, take longer to replace and can be upgraded much more cost effectively!

Such unmanned aerial vehicles or UAVs are now available<sup>6</sup>, and in April 2001, an RQ-4 *Global Hawk* UAV flew non-stop from Edwards Air Force Base in the US to RAAF Base Edinburgh in Australia, becoming the first pilotless aircraft to cross the Pacific Ocean. Though what the passengers in a commercial airliner might think about leaving the pilot behind remains to be seen!

---

<sup>6</sup> With the MQ-1 *Predator* being probably the best known

# Chapter 15

## Mechatronic Futures

David W. Russell<sup>1</sup> and David Bradley<sup>2</sup>

### 15.1 Introduction

In Chapter 1, some of the future potential for mechatronics was hinted at in relation to areas such as manufacturing, health and transport. In this chapter, the aim is to round out the book by revisiting some of these areas in more detail and to examine other areas where mechatronics has the possibility of making a significant contribution. In doing so, the authors make no claim to having any particular or special insight, recognising that, as Yogi Bera<sup>3</sup> is once reputed to have said,

It's tough to make predictions, especially about the future.

Nevertheless, it is perhaps appropriate when dealing with a subject such as mechatronics to try to present a view not only of its current applications, as evident in the previous chapters, but of directions for future development, and this is the aim of this concluding chapter. The textbook has asserted that, among other connections, mechatronics systems blend hardware, software and computer science in their many aspects.

Mechanically speaking, the development of new materials, manufacturing systems and products is relatively time-consuming and slow to market. The user market is making software systems seem fairly stable, as proven by the Windows Vista<sup>®</sup> situation when it was released worldwide in January 2007. On the other hand, the scope and complexity of computer science applications appear limitless in their influence in regard to human factors, control, and algorithmic properties. In some regards, algorithms are pushing the boundaries of artificial intelligence and self realisation.

---

<sup>1</sup> Penn State Great Valley, USA

<sup>2</sup> University of Abertay Dundee, UK

<sup>3</sup> Baseball player and manager, primarily with the New York Yankees.

The quote is also attributed to the Danish cartoonist Robert Storm Petersen (1882–1949).

Technology in general is a good thing, as illustrated by how it appears almost constantly in the vernacular of politicians, corporations, universities, professionals, students, and children. Mechatronics has been a somewhat silent or invisible contributor to many systems, and yet is a true technology whose strength is that, when applied correctly, it is almost transparent to the user.

This concluding chapter attempts to give a brief look at the future potential of mechatronics and is divided into eight sections; challenges, home based systems, e-Medicine, transportation, manufacturing, communications, nanotechnology, advanced algorithms, and a conclusion. Because of the rapidly changing nature of some of the technologies listed, the authors have elected to provide many of the references as websites so that the interested reader can access developments as they occur and *surf* for other related works<sup>4</sup>.

## 15.2 Challenges

A cursory review of archival journals in mechatronics and associated topics surely confirms that:

In the 21st Century, brainpower and imagination, invention and the organisation of new technologies are the key strategic ingredients. Lester C Thurow – Sloan School of Management.<sup>5</sup>

Because of the incredible flexibility that the design of mechatronic systems provides, new products have a reduced time-to-market and enjoy a shorter product life time while promoting increased customer expectations with every new release. It is now not enough that a wireless telephone handles conversations. It must now play music and movies, surf the web, enable email and “texting” and serve as a alarm in the event of an emergency; and it is all done via a rolling touch screen.

Using component technology that enables systems to be assembled from a selection of well tested units, a “new” product can be brought to market rapidly, be inexpensive and yet be profitable. The device might even be sold at a loss in favour of a monthly service fee. Vendors of technological products are more than aware that the world is their marketplace and that this will mandate new support and retirement paradigms. Using the Blackberry<sup>®</sup> example from the previous paragraph, some countries offer a trade-in program in an attempt to recoup value and disassemble their products rather than have consumers discard their older models.

This also helps keep long lifetime and hazardous materials out of the landfills and gives the manufacturers access to gently used components. It is apparent that the Knowledge Economy continues to dominate in our business world and infiltrates almost all facets of life in the 21st century. When used appropriately and

---

<sup>4</sup> Always remembering the potentially transient nature of such sites

<sup>5</sup> Quoted in ‘*Visions: How science will revolutionize the 21st century*’ by Michio Kaku

ethically, technology based products, including many mechatronic systems, have real added value in the commonplace of everyday living. Misuse for whatever reason, on the other hand, creates societal issues that engender prohibition and regulation.

While the social aspect of technology is a far reaching topic and way beyond the scope of this volume, Sellen *et al.* [1] ask several poignant rhetorical questions, including:

- Who should have the right to access and control information from imbedded devices?
- Do we want copyright on our own digital footprints (e.g., photos on a web site)?
- Are children to be held responsible for the consequences of their interactions with technology?

These issues will all need addressing as technology continues to pervade how, when, and where we live and work.

### 15.3 Home Based Technologies

Many home based systems are increasingly using voice control to initiate or close down electromechanical devices. The obvious application being that of home help systems in which a person who may have limited ambulation can summon assistive services. There are a growing number of smart appliances which, besides offering busy persons help with their schedule, for example, automatically reordering basic foods as they are consumed, can also watch for expiration dates, flag low medication levels and order prescription refills.

On the domestic front, sales of the Roomba™ (see Figure 15.1), a robotic vacuum cleaner that was introduced by iRobot [2] in 2002, as of January 2008, has exceeded 2.5 million units. This mechatronic device roams around a domicile, cleaning as it goes along while planning coverage paths and escape routes in anticipation of being “cornered”.



**Fig. 15.1** Third Generation Roomba docked in base station<sup>6</sup>

---

<sup>6</sup> [en.wikipedia.org/wiki/Roomba](http://en.wikipedia.org/wiki/Roomba)



The fully fledged personal digital assistant (PDA) that will plan our daily wardrobe from an inventory of clothes based on our schedule, e.g., confirm the location and forecast weather with another PDA, may not be that far off as *Networkworld* [3] suggests:

Imagine a robot that hands you a beer and then cleans your kitchen and living room.

In addition, mechatronic devices will offer enhanced safety and security systems, for example, by relaying vital signs to an incoming ambulance crew and opening the front door when a special code is entered. It is very possible and somewhat available to remotely monitor home systems such as heating, electricity, and fire alarms, reporting failures and errors and provide real-time diagnostics to affect speedier repair. The smart house will adapt to a person's lifestyle, for instance, knowing the difference between weekdays and weekends, vacations, and regular visitors.

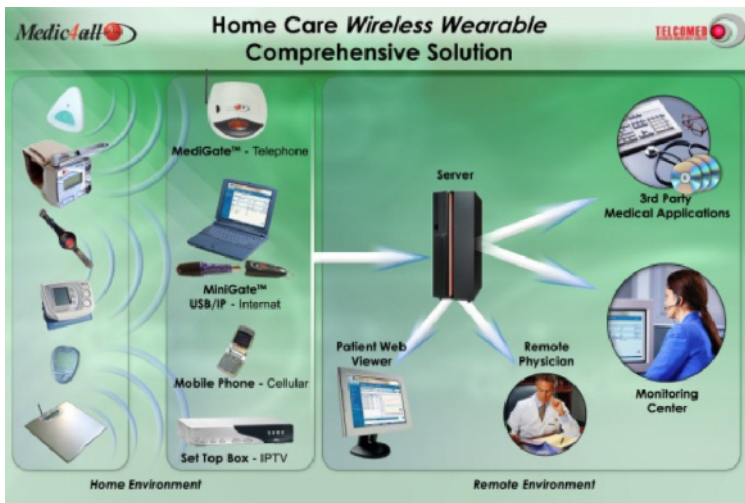

**Fig. 15.2** Homecare Wireless Wearable Home Care<sup>7</sup>

## 15.4 Medicine and eHealth

Mechatronics is an essential component in the increasing use of technology to support independent living by the elderly and infirmed, and those requiring only some degree of care, while allowing them to retain their residence and independence. By creating a safe and secure environment, persons who might otherwise need institutional care can be monitored for movement, location status and medication schedules. Furthermore, teleconsultations will replace GP and

<sup>7</sup> © 2009, Telcomed Advanced Industries Ltd. ([www.telcomed.ie](http://www.telcomed.ie))

nurse visits so that home based patients will become an integral part of their treatment program, which has been shown [4] to be more effective medically and economically than institutional care. Figure 15.2 illustrates the use of wearable and even implantable devices in a home based medical care system.

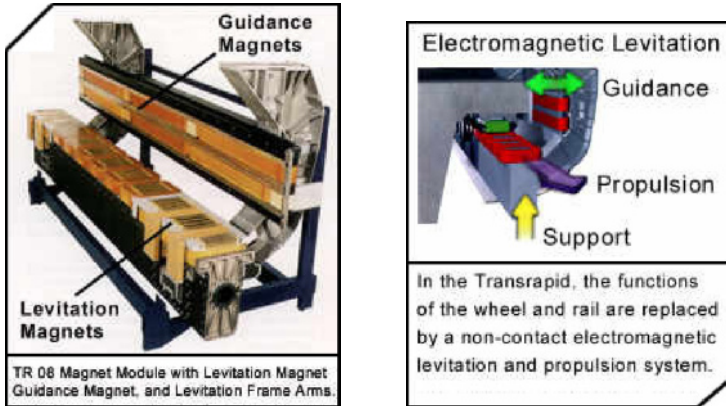

Fig. 15.3 A MAGLEV propulsion system

### 15.5 Transportation

Another area that affects everyone is that of transportation, be it personal or commercial. There is already a much greater use of electric hybrid vehicles, which in the US is being supported by tax breaks for users. In the future, the currently limited mileage on an eight hour charge will increase beyond 100 miles (160 km), and there are already preliminary designs for a smart parking garage where entering vehicles are assigned a parking space where a plug in recharge facility will be available. On exit, the user pays for parking and electricity. Hydrogen based fuel cells are another promising technology just waiting for efficiency levels to become commercially acceptable.

Highway systems are burgeoning to meet the increased demand for trip efficiency on the roadways. Using a transponder (e.g., EZPass™ in the US) or a credit card, vehicles can more rapidly pay tolls or congestion charges without stopping for change; receipts are then available from a website. As automobiles become smarter or incorporate self-parking [5, 6] and collision avoidance systems, it is only a matter of time before guided vehicle technologies will auto-pilot cars on special lanes on motorways. It has been suggested that cars could travel at 70 mph in a batch stream only inches apart. Amusingly, it is gaps in the stream into which deer or other animals can stray that is posing the biggest problem for this concept.

Advanced, high speed mass rapid transit systems are appearing worldwide that use mechatronic components to synchronise station stops, station announcement systems, fare collection units, and steer the train. For long haul journeys, ultra high speed trains using MAGLEV [7] will become commonplace and enable travel at speeds up to 250 mph. Figure 15.3 illustrates MAGLEV technology.

In the field of aeronautics, super jumbo jets such as the Airbus 380 [8] will carry 555 passengers distributed between two decks, with a system that provides automatic takeoff and landing functions with greatly reduced noise levels. Mechatronic systems operate the autopilot, though in the future, will include much more intelligence than is available at present. For example, future autopilot systems will observe debris on the runway, icing of the wings, and birds in flight and take remedial action to prevent accidents.

## 15.6 Manufacturing, Automation and Robotics

Increasing levels of machine intelligence [9] enable deep cooperation with humans over a wide range of task domains. In addition to acting as the stronger partner in manipulating heavy work-pieces, robots can also provide autonomous service in handling hazardous materials [10] and do so continuously without regard for the working environment. Figure 15.4 shows a large mechatronic robot handling hazardous materials.



**Fig. 15.4** A robot handling hazardous waste after an accident <sup>8</sup>

In more advanced manufacturing systems, workflow is established using self reconfigurable machines [11, 12] that bid [13] on an incoming job based on their availability and proximity. The semiconductor industry is very advanced in the use of material handling systems [14] and automated assembly and disassembly [15].

---

<sup>8</sup> [robotsnews.blogspot.com/2007/05/robot-teams-handle-hazardous-jobs.html](http://robotsnews.blogspot.com/2007/05/robot-teams-handle-hazardous-jobs.html)

## 15.7 Communications

Communications networks provide a basis for a number of mechatronic systems by linking together distributed system elements. Developments such as self-organising sensor networks [16, 17] allow for the possibility of monitoring information of all types more effectively than previously. Thus, a network of such sensors could form the basis of a telecare or eHealth network, or provide for the monitoring of the operation of a smart building environment [18, 19]. At another level, advanced communications will support collaborative working such as evinced by swarm robots where communication and the sharing of data among the swarm members will support the achievement of higher levels of functionality [20, 21].

Advanced communications also support operation of systems such as unmanned aerial vehicles and sub-sea vehicles by providing support for operator interaction within the operational strategies for such systems [22, 23].

## 15.8 Nanotechnologies

The use of nanotechnologies is well known in the semiconductor industry [24], where billions of computational elements can be integrated onto a single chip, and is predicted to increase in other applications using nanomechatronic devices. This leads to concepts such as that of medical nanobots which will perform continuous *in vivo* procedures that will positively affect lifespan and quality of life. One study [25] suggests that:

hoards of medical nanobots much smaller than a cell will cruise through your body, repairing damaged DNA, attacking invading viruses and bacteria, removing contaminants, and correcting bodily structures at the molecular level.

The use of implanted diagnostic and maintenance nanosystems for both machines and humans will facilitate early detection of abnormalities and first level repair. Should a problem be outside of the capability of the nanobot, the swarm will report the discontinuity and trigger more conventional diagnostic procedures. Perhaps more mundanely and certainly in the shorter term, implantable devices such as micro-pumps will be used to control the release of drugs such as insulin based on the direct measurement of blood chemistry from implanted sensors.

One area that has been newsworthy is the possibility of enhancing human physiology through micro and nanobionics. Carbon nanotubes are very strong and can be added to natural or manufactured objects, such as reported by a group of scientists at MIT in strengthening airplane wings tenfold [26] or in the enhancement of weak human muscles and bones.

Nanotechnology enables bespoke materials to be synthesised at the submolecular level that possesses inherent properties such as strength or elasticity. For example, it is now possible to dope carbon with nanomaterials to produce

super-diamond strength and resiliency. Smart materials using integrated micro-actuators are already available [27] that react to seismic activity and allow the foundations of bridges to stiffen during a storm and relax when an earthquake would damage its surfaces.

## 15.9 Advanced Algorithms

The computational components of mechatronic systems vary from the implementation of simple control systems, to intelligent self organisation. Three examples follow. Neural networks [28] are commonplace in mechatronic systems that need to learn how to optimise control tasks over time. Research into particle swarm technology [29] is proving useful in the solution of *hard* scheduling problems where the complexity of the problem baffles simple tree searching. One of the apparent defects is the difficulty of coding the desire of the swarm to branch out beyond a promising solution path to uncharted areas within the solution space. A similar method that ages data so that the trajectory of a solution is forced to forage into new spaces uses the ant colony optimisation (ACO) metaphor [30].

## 15.10 Artificial Intelligence

The techniques of artificial intelligence [31–34] are likely to make an increasingly significant contribution to all aspects of mechatronics in coming years. In design, the use of recommender systems [35–37] linked to knowledge about manufacturing capability and capacity, and smart databases will support the effective use of materials and facilities as well as supporting design modification and re-use rather than redesign. In addition, the deployment of data mining and knowledge discovery [38, 39] will support developments such as case-based reasoning to enable the more effective use of known solutions and methods as well as supporting the development of new solutions.

At the device level, the introduction of autonomous decision making strategies such as those associated with the DARPA Grand Challenge and Urban Challenge [40, 41] vehicles will support the development of newer and smarter systems and products [42]. These will be supported by the deployment of self-organising networks of sensors and devices, which of themselves will form the basis for distributed computing networks at the system level, as for instance in relation to developments in automotive technology<sup>9</sup>.

In medical technology, developments in prostheses will increasingly rely on the smart integration of drives and actuators with novel sensors to enable more

---

<sup>9</sup> See, for instance, Chapter 6 – *Mechatronics and the Motor Car*

realistic and lifelike behaviours<sup>10</sup>. Similarly, enhancements in system intelligence will support advanced healthcare strategies which will in turn increase independence for a wide range of individuals.

## 15.11 Conclusions

The authors hope that readers of the text have enjoyed the case studies, fundamental research, applications and opinions of the contributors to this text. Above all else, it is their express desire that readers become convinced of at least the following four precepts. Firstly, that mechatronics in action is a reality. Secondly, that the application of the principles of mechatronic design ensure from the onset that systems are inherently sustainable, reliable and environmentally responsible. Thirdly, that mechatronics is an integrative discipline that synergistically applies innovations in many areas of technology. Lastly, that the future is indeed now.

## References

1. Sellen A, Rodgers Y, Harper R, Rodden T, (2009) Reflecting Human Values in the Digital Age, Communications ACM, **52**(3)
2. www.irobot.com
3. www.networkworld.com/news/2008/030608-open-source-robot.html
4. www.intel.com/healthcare/telehealth/
5. www.worldcarfans.com/9081230.005/ford-self-parking-system-announced-for-lincoln-mks-and-mkt
6. www.economist.com/science/tq/displaystory.cfm?story\_id=13174487
7. www.maglevpa.com/
8. www.aerospace-technology.com/projects/a380/
9. Rao HA, Gu, P (1994) Expert self-organizing neural network for the design of cellular manufacturing systems, J. Manufacturing Systems, **13**(5):346–359.
10. <http://www.ece.rice.edu/ece/Robotics/>
11. Schild K, Bussmann S (2007) Self-Organization in Manufacturing Operations, Communications of the ACM, **50**(12):74–78
12. Kubota N, Fukoda T (1999) Structured intelligence for self-organizing manufacturing systems, J. Intelligent Manufacturing, **10**(2):121–133.
13. Qiu R, McDonnell P, Joshi S, Russell DW (2005) A Heuristic Game Theoretic Approach to Resource Sharing in Reconfigurable Manufacturing, Int. J. of Adv. Manufacturing Tech, **25**(1-2):78–87
14. Zhang MT (2007) e-Manufacturing in the Semiconductor Industry, Editorial in IEEE Trans. on Automation Science and Engineering, **4**(4):485–487
15. Kim HJ, Chiotellis S, Seliger, G (2009) Dynamic process planning control of hybrid disassembly systems, Int. J. of Adv. Manufacturing Tech, **40**:1016–1023
16. www.eng.auburn.edu/users/lim/sensit.html

---

<sup>10</sup> See, for instance, Chapter 9 – *Intelligent Prosthesis – A Biomechatronics Approach*

17. [www.theengineer.co.uk/Articles/310036/Self-organising+sensor+network.htm](http://www.theengineer.co.uk/Articles/310036/Self-organising+sensor+network.htm)
18. [www.arup.com/feature.cfm?pageid=5844](http://www.arup.com/feature.cfm?pageid=5844)
19. [www.computing.co.uk/computing/news/2229116/hsbc-smart-building-technology](http://www.computing.co.uk/computing/news/2229116/hsbc-smart-building-technology)
20. [www.swarm-robotics.org/](http://www.swarm-robotics.org/)
21. Beni G (2005) *From Swarm Intelligence to Swarm Robotics*, Springer Berlin / Heidelberg
22. [www.fas.org/irp/program/collect/uav.htm](http://www.fas.org/irp/program/collect/uav.htm)
23. [en.wikipedia.org/wiki/Remotely\\_operated\\_vehicle](http://en.wikipedia.org/wiki/Remotely_operated_vehicle)
24. Mouli C, Carriker W, (2007) Future fab: How software is helping Intel go nano and beyond, *IEEE Spectrum*, March
25. [home.mchsi.com/~deering9/benefits.html](http://home.mchsi.com/~deering9/benefits.html)
26. Eaton K, (2009) Airplane Skins: 10 Times Stronger with Nano-Stitching, [www.fastcompany.com/blog/kit-eaton/technomix/nanotubes-can-make-super-strong-materials-10-times-stronger](http://www.fastcompany.com/blog/kit-eaton/technomix/nanotubes-can-make-super-strong-materials-10-times-stronger)
27. Bonsor K, (2001) How Smart Structures Will Work, [science.howstuffworks.com/smart-structure.htm](http://science.howstuffworks.com/smart-structure.htm)
28. Sanjari M, Karimi TA, Movahedi MR (2009) An optimization method for radial forging process using ANN and Taguchi method, *Int. J. of Adv. Manufacturing Tech*, **40**:776–784.
29. Chen Y, Lin C (2007) A particle swarm optimization approach to optimize component placement in printed circuit board assembly, *Int. J. of Adv. Manufacturing Tech*, **35**:610–620.
30. Alaykýran K, Engin O, Döyen A (2007) Using ant colony optimization to solve hybrid flow shop scheduling problems, *Int. J. of Adv. Manufacturing Tech*, **35**:541–550.
31. Minsky M (2006), *The Emotion Machine*, Simon & Schuster, New York
32. Buchanan BG (2005) A (Very) Brief History of Artificial Intelligence, *American Association for Artificial Intelligence*, Winter:53–60
33. McCorduck P (2004) *Machines Who Think* (2nd ed.), AK Peters Ltd
34. Luger G, Stubblefield W (2004), *Artificial Intelligence: Structures and Strategies for Complex Problem Solving* (5th ed.), The Benjamin/Cummings Publishing Company Inc.
35. Jannach D, Zanker M, Konstan J (Eds.) (2008) Special issue on Recommender Systems, *AI Communications*, 21(2–3)
36. Felfernig A, Friedrich G, Schmidt-Thieme L (2007) Special Issue on Recommender Systems, *IEEE Intelligent Systems*, **22**(3)
37. Adomavicius G, Tuzhilin A (2005) Toward the Next Generation of Recommender Systems: A Survey of the State-of-the-Art and Possible Extensions, *IEEE Trans. Knowledge and Data Engineering* **17**(6):734–749
38. Kantardzic M (2003) *Data Mining: Concepts, Models, Methods, and Algorithms*, John Wiley and Sons
39. Jiawei Han, Kamber M (2006) *Data mining: concepts and techniques*, 2nd Edn, Morgan Kaufmann
40. [www.darpa.mil/grandchallenge/index.asp](http://www.darpa.mil/grandchallenge/index.asp)
41. Patz BJ, Papelis Y, Pillat R, Stein G, Harper D (2008) A Practical Approach to Robotic Design for the DARPA Urban Challenge, *J. Field Robotics* **25**(8):528–566
42. Nassiraei AAF, Kazuo Ishii (2007) Concept of Intelligent Mechanical Design for Autonomous Mobile Robots, *J. Bionic Engineering* **4**:217–226

# Authors

## Contributing Editors

### *David Bradley*

One of the founders of the Mechatronics Forum<sup>1</sup>, David Bradley, has been involved in research and education in mechatronics since the mid-1980s when he was at Lancaster University. In 1989, he organised the first in the series of Mechatronics Forum conferences and was responsible for establishing one of the first mechatronics programmes in the UK.

Prof. Bradley's diverse research interests have focused on the development of mechatronic systems including advanced robotics in construction and physiotherapy and mechatronics design principles. Current research includes the design of intelligent and mechatronic systems, system modelling, automated systems for physiotherapy and applications in telecare and telehealth. He has acted as a consultant on mechatronics education and has been a speaker at international conferences and workshops, most recently in China, South Africa and South America.

At the time of writing, Prof. Bradley is a Professorial Consultant in Mechatronic Systems at the University of Abertay Dundee, a visiting professor at Sheffield University and a member of the Mechatronics Forum Committee as well as being a Fellow of the IET<sup>2</sup>.

He is the co-author of two textbooks on mechatronics as well as many papers on its underlying philosophy, the nature of mechatronics education and technical issues such as construction robotics and telecare systems.

### *David W. Russell*

David W. Russell is currently Professor of Electrical Engineering at the School of Graduate Professional Studies at Penn State Great Valley in the Philadelphia suburbs, where he was senior division head for engineering and information science for twelve years.

Prior to joining Penn State, Prof. Russell held several senior technical executive positions working for systems integration companies. In these roles, he designed

---

<sup>1</sup> As the UK Mechatronics Forum with Prof. Jim Hewitt and Prof. Jack Dinsdale

<sup>2</sup> The Institution of Engineering and Technology, previously the Institution of Electrical Engineers



and implemented several factory information systems in companies throughout North America. He is ‘Editor for the Americas’ for the Springer *International Journal of Advanced Manufacturing Technology* and has organised several international conferences, and is a popular keynote speaker at worldwide events.

Prof. Russell’s current research interests include the measurement of automation effectiveness, intelligent control of nonlinear dynamics and the application of systems engineering principles to the medical domain.

David W. Russell is a Fellow of the IMechE<sup>3</sup>, a Fellow of the IET, a Fellow of the British Computer Society in the UK, a member of the Mechatronics Forum Committee, a senior member of the IEEE<sup>4</sup> and a member of several other professional societies in the USA. He also serves as the Americas Forum Chair and is a member of the International Strategy Board of the Institution of Mechanical Engineers.

## Contributing Authors

### Foreword – The History of the Mechatronics Forum

#### *Memiş Acar*

Dr. Memiş Acar<sup>5</sup> is a Fellow of both the ASME<sup>6</sup> and IMechE, and a Chartered Engineer. He serves on the IMechE's Mechatronics, Informatics and control Group and chaired the Mechatronics Forum Committee for two terms. Dr. Acar is currently a Senior Lecturer in the Wolfson School of Mechanical and Manufacturing Engineering at Loughborough University and an Adjunct Professor at North Carolina State University in the USA.

### Preface

#### *Geoff Roberts*

A past chairman of the Mechatronics Forum, a member and past chairman of the IFAC<sup>7</sup> Technical Committee on Marine Systems and a member of the IFAC Technical Committee on Mechatronic Systems, Geoff Roberts is Professor of

---

<sup>3</sup> Institution of Mechanical Engineers

<sup>4</sup> Institute of Electrical and Electronics Engineers

<sup>5</sup> Dr. Acar is also the author of Chapter 5 in this book and further biographical details can be found under that heading.

<sup>6</sup> American Society of Mechanical Engineers

<sup>7</sup> International Federation of Automatic Control

Mechatronic Systems in the Control Theory and Applications Centre at Coventry University in the UK.

He has been active in the area of mechatronic systems for more than twenty years, particularly in mechatronics applications in marine systems where he has made contributions to integrated ship steering and stabilisation, intelligent autopilots and guidance and control of underwater vehicles. He is presently working on fault detection and data handling for underwater vehicles and parallel multi-model switched control for integrated ship roll stabilisation.

## **Chapter 2 – Consumption to Contribution: Sustainable Technological Development Through Innovation**

*John H. Millbank*

John H. Millbank is an independent technology transfer consultant with extensive industrial and academic background in research and development, teaching, and the application of technological innovations. He is both a chartered mechanical and marine engineer as well as a European engineer with industrial experience in offshore, manufacturing, nuclear and transport sectors in addition to marine civil engineering and advanced robotics. His wide ranging technological engagements have included pioneering mechatronic applications of subsea pipeline and cable installation systems, integrated FMCG production facilities and generic developments robotic mobility and locomotion. Current interests include the organisational as well as technological aspects of innovation processes and its impact on social, economic and sustainable development.

## **Chapter 3 – The “Revolution”: a Small Company Revived**

*David Dawson*

David Dawson was, with Prof. David Bradley, a member of the team that in 1986 launched at Lancaster University the UK's first integrated undergraduate mechatronics teaching programme. He also played a major role in setting up the first International Conference in Mechatronics in 1989, helped in the development of the Mechatronics Forum and contributed to two substantial textbooks in the field. His somewhat idiosyncratic approach to engineering education led him, after several years in industry with Rolls Royce and ICI, to join in a collaborative relationship in support of Mike Sharman at Cambridge University Engineering Department, whose unique *Advanced Course in Design Manufacture and Management* [ACDMM] accelerated the careers of many who are now leaders of international companies.

In spite of gaining a 1st Class Honours Degree in Mechanical Engineering from UMIST and a lively interest in reading research publications<sup>8</sup>, he retained a strong bias towards industry, generally preferring onsite design assignments, industrial investigations and troubleshooting rather than strictly academic pursuits. However, much of this experience, suitably self-censored, informed his teaching and significantly contributed to the structuring of the original mechatronics courses at Lancaster. Thus, while contributing to the taught programmes and individual student projects at Lancaster University, he undertook many industrial consultancy assignments and supervised a succession of links between academia and industry. In the last of these *Knowledge Transfer Partnerships* [KTP],<sup>9</sup> the programme with a small manufacturing company won the top award for such links in the UK in 2002. This experience forms the basis for the case study in this book.

## Chapter 4 – A Mechatronic Design Process and Its Application

### *Xiu-Tian Yan*

Dr. Xiu-Tian Yan is a Senior Lecturer and Deputy Director of Teaching and Learning and Postgraduate Courses Director in the Department of Design, Manufacture and Engineering Management at the University of Strathclyde in the UK. Previously, he was a research associate at Engineering Design Centre, Lancaster University, working on the Schemebuilder project and received his Ph.D. from Loughborough University in 1992. He is a Chartered Engineer and a member of IET<sup>10</sup>.

His research interests include mechatronic systems and multiperspective mechatronic system modelling, design and simulation; the proactive computer support of product life-cycle synthesis and design; product generalisation and configuration design and constraint based insightful engineering design support. He has published over 130 technical papers in major international journals, and edited books and conferences in these fields. He has also written or edited eight books.

He has organised several international conferences/symposiums as a Chairman or session chairman, including the EASED2004, ICADAM 2008, ICED2007 and REM2009. He is currently Vice-Chairman of the Mechatronics Forum in the UK. He is also actively involved in various technical and scientific committees of the Institution of Mechanical Engineers as well as with international conferences and journals as a technical reviewer. He is an Invited Professor or Guest Professor at several French and Chinese higher institutions and has been awarded and managed or been otherwise associated with 25 research projects in the above fields.

---

<sup>8</sup> At a time when these were generally free to undergraduates

<sup>9</sup> Previously known as the *Teaching Company Scheme*

<sup>10</sup> The Institution of Engineering and Technology, previously the Institution of Electrical Engineers

*Rémi Zante*

Rémi Zante graduated with a master's degree in Product Design Engineering from the Department of Design Manufacture and Engineering Management at the University of Strathclyde, Glasgow in 1999. Upon graduating he spent five years working in the automotive sector on vehicle drive trains for commercial vehicles. He gained his Ph.D. from the University of Strathclyde in 2008 in the field of mechatronics developing low flow lubricant dispensing systems. This ESPRC funded research was sponsored by Scottoiler Ltd. and has been presented at the last two Mechatronics Forum Biennial International Conferences. Interests include the microfluid control and the control of microflows by mechatronic systems, and product simulation and system modelling. He is currently a research fellow at the Advanced Forming Research Centre based at the University of Strathclyde developing a forming process strategy for Rolls Royce Plc. and conducting research into the next generation of forming processes for the aerospace industry.

**Chapter 5 – A Mechatronic Design of a Circular Warp Knitting Machine***Memiş Acar*

Dr. Memiş Acar is currently a Senior Lecturer in the Wolfson School of Mechanical and Manufacturing Engineering at Loughborough University and an Adjunct Professor at North Carolina State University in the USA. He received his BS degree in Mechanical Engineering in 1974 from the Middle East Technical University (METU) in Ankara, Turkey, an MSc from the University of Manchester Institute of Science and Technology in 1979, and a Ph.D. in Mechanical Engineering from Loughborough University of Technology in 1984.

Dr. Acar is a Fellow of both the ASME<sup>11</sup> and IMechE<sup>12</sup> and a Chartered Engineer. He serves on the IMechE's Mechatronics, Informatics and control Group and chaired the IMechE Mechatronics Forum Committee for two terms. He is currently the Chair of the ASME UK and Ireland Section. He co-chaired the IMechE Mechatronics Forum Conference (Ankara) in 2004 and was the Technical Programme Chair of the ASME ESDA Conference (Manchester) in 2004.

Dr. Acar has published over 130 refereed research papers in academic journals and international conference proceedings, and has served as a member of the Editorial Board of the Mechatronics Journal, Pergamon, Elsevier Science and currently the International Journal of Mechatronics. He is also currently a member of the Editorial Board of the Manufacturing Systems, Inderscience Publishers. He was honoured with the Thomas Hawksley Memorial Lecture of the IMechE in 1989, won a NATO ASI grant in 1992 and a Royal Academy of Engineering Global Research Award for a secondment to North Carolina State University.

---

<sup>11</sup> American Society of Mechanical Engineers

<sup>12</sup> Institution of Mechanical Engineers

## **Chapter 6 – Mechatronics and the Motor Car**

*Derek Seward*

Derek Seward is Professor of Engineering Design at Lancaster University and a former Head of Engineering. His research interests lie in intelligent mobile robotics with specific application to construction and nuclear decommissioning. He was involved in the development of a robot excavator and intelligent control of heavy hydraulic construction plant. He also has an interest in the safety of complex mechatronic systems and teaches a master's level module on the Design of Safety-Critical Systems. He is a former board member of the International Association for Automation and Robotics in Construction and has published widely in the field.

## **Chapter 7 – Multi-mode Operations Marine Robotic Vehicle – a Mechatronics Case Study**

*Daniel Toal*

Daniel Toal was born in Dublin in 1961 and received his Hon Dip EE from the Dublin Institute of Technology and his BSc (Eng) in Electrical Engineering from the Dublin University (Trinity) in 1984, his MSc in Manufacturing Systems Engineering from Cranfield University, UK, in 1986 and his Ph.D. from the University of Limerick (UL), Ireland in 2004. He worked for some years in the areas of electrical/high voltage engineering, automation, and manufacturing systems consultancy before taking up an academic position at UL in 1992.

He is currently a senior lecturer in electronics in the Department of Electronic and Computer Engineering at UL. His research interests include robotics, land-based and marine robots (both ROVs and AUVs), industrial robots, controller design, sensor design and integration, motion control, subsumption and behaviour based control and the application of these technologies to autonomous robotics.

Over the last seven years, his focus in robotics research has been in the marine environment as a domain where the natural challenges imposed by the subsea environment make robotics a must for subsea developments, mapping, exploration and intervention. Dr. Toal is the founder and director of the Mobile & Marine Robotics Research Centre within the Department of Electronic and Computer Engineering, UL. He is also a director of the Charles Parsons Initiative on Energy and Sustainable Environments at UL and Programme Director for the Bachelor of Engineering in Robotics at UL.

*Edin Omerdic*

Edin Omerdic received the Dipl. Eng. and MS degree in electrical engineering from the University of Zagreb, Zagreb, Croatia, in 1997 and 2001 respectively, and a Ph.D. in electrical engineering from the University of Wales, Newport, UK in 2004. He is currently a Senior Research Fellow for Ocean System Modelling, Charles Parsons Initiative, at the Mobile and Marine Robotics Research Centre, University of Limerick, Ireland.

His research interests include modelling and simulation of dynamic systems (marine platforms, ocean dynamics & disturbances), real-time simulators, virtual reality, development and design of guidance, navigation and control system for marine vessels, nonlinear control systems, implementation of soft-computing techniques in intelligent systems, underwater robotics and fault-tolerant systems.

*James Riordan*

James Riordan received the Bachelor of Electronic Engineering in 2002 with the Department of Electronic and Computer Engineering, University of Limerick, Ireland. He was awarded the Ph.D. degree in Computational Ocean Acoustics in 2006 for research conducted with the Mobile & Marine Robotics Research Centre, where he is currently a Postdoctoral Research Fellow. His research interests include: marine survey operations, real-time imaging-sonar simulation, parallel computing, fractal modelling, multi-resolution model abstraction, automated sonar data processing, & 3D visualisation.

*Seán Nolan*

Seán Nolan graduated from the University of Limerick with a Bachelor of Engineering Degree in Electronics in 2001. He then joined the Mobile and Marine Robotics Research Centre (MMRRC) at the University of Limerick where he was awarded a M. Eng for work carried out in the area of Autonomous Underwater Vehicle test-bed development in 2003. Seán subsequently began research in the area of intelligent sensor strategies for use on underwater vehicles and was awarded a Ph.D. at the University of Limerick in 2007 for his work on the characterisation and development of close-range ultrasonic collision avoidance sensors.

Since then, Sean has worked in the MMRRC as a research fellow on a study for the Irish Marine Institute examining technologies for use in offshore aquaculture in high energy sites and on a collaborative European Interreg project 'MARINE', focused on Marine Incident response. Sean is currently working as a research and development engineer on the MMRRC's state-of-the-art remotely operated vehicle (ROV). Successful trials of ROV<sub>LATIS</sub> took place at the beginning of March 2009 aboard the RV Celtic Explorer.

## **Chapter 8 – Wireless Communication Technology for Modular Mechatronic Controllers**

### *Glen Bright*

Professor Glen Bright obtained his BSc, MSc and Ph.D. at the University of Natal in the area of robotics and manufacturing. His research interests include reconfigurable manufacturing systems (RMS) and autonomous mobile robots (AMR) for advanced manufacturing materials handling. His research provides industry with solutions for advanced manufacturing problems. Research is achieved through local and overseas research collaboration.

Prof. Bright has published extensively in the field of advanced manufacturing, mechatronics and robotics. He is currently head of school in Mechanical Engineering at the University of Kwa-Zulu Natal in the Republic of South Africa (RSA).

### *Nkgatho Sylvester Tlale*

Dr Tlale has published extensively in the fields of advanced manufacturing, mechatronics and robotics. He is currently a Research Group Leader at the Council for Scientific and Industrial Research (CSIR) in the RSA. Prior to CSIR, Dr. Tlale held several academic positions at Massey University (New Zealand) and the University of Pretoria (RSA), respectively. In these roles, he conducted research and taught several courses in advanced manufacturing, mechatronics and robotics. His current research interests are AMR, parallel kinematics manipulators and RMS.

### *Christopher M. Kumile*

Christopher M. Kumile is a Senior Lecturer of Manufacturing Engineering at Tshwane University of Technology, Pretoria, RSA. Chris has extensive experience in the engineering education sector and has published specifically in advanced manufacturing technology and mechatronics. He received his B Eng. (Hons) and MSc degrees in Manufacturing Engineering from Portsmouth University, UK. He is currently doing his Ph.D. in Mechanical Engineering at the University of KwaZulu Natal. His areas of expertise are mechatronics, robotics, and advanced manufacturing systems.

## **Chapter 9 – The Utility Function Method for Behaviour Selection in Autonomous Robots**

*Mattias Wahde*

Dr. Mattias Wahde received his Ph.D. in 1997 from Chalmers University of Technology and was then a postdoctoral fellow at the Nordic Institute of Theoretical Physics (NORDITA) from 1997 to 1999. He then returned to Chalmers as an assistant professor. Since 2002, he has been an associate professor at the Department of Applied Mechanics where he leads the Adaptive systems research group whose research is centred on autonomous robots, particularly regarding behaviour selection methods. Dr. Wahde's research interests also include stochastic optimisation and biologically inspired optimisation methods. Dr. Wahde is also a co-director of the international master's programme for Complex Adaptive Systems at Chalmers University of Technology There, he teaches several courses on topics such as stochastic optimisation methods, autonomous agents, and humanoid robotics. He has published around 50 scientific journal and conference papers, and is also the author of a recent book on biologically inspired optimisation methods.

## **Chapter 10 – Force Sensing in Medical Robotics**

*Kaspar Althoefer*

Kaspar Althoefer is a Senior Lecturer in the Department of Mechanical Engineering at King's College London, leading research on Sensing and Embedded Intelligence in the Centre for Mechatronics and Manufacturing Systems (CMMS). Being engaged in research on mechatronics since 1992, he has considerable expertise in the areas of sensing, and data analysis and interpretation using neural networks and fuzzy logic as well as robot-based applications. He has published over 100 refereed research papers in international journals and conference proceedings. He is also a Member of the IEEE and IET.

*Hongbin Liu*

Hongbin Liu received the B.Sc. degree in Materials Control Engineering from Northwestern Polytechnical University, China in 2005. In 2006, he was awarded the M.Sc. with Distinction in Mechatronic and MSc Mechatronics Prize (*Best Overall Student*) from King's College London, UK. He is currently pursuing a Ph.D. degree at King's College London. His research focuses on the dynamics of tool-biological tissue interaction for medical applications.



*Pinyo Puangmali*

Pinyo Puangmali received the B.Eng. degree in mechanical engineering from Chiang Mai University, Thailand in 1999 and the M.Sc. degree in mechatronics from the University of Siegen, Germany, in 2004. He is currently pursuing a Ph.D. in miniaturised force sensors for medical applications at King's College London. His research interests also include mathematical modelling of dynamic systems and robotics.

*Dinusha Zbyszewski*

Dinusha Zbyszewski graduated from King's College London with a MEng degree in Mechanical Engineering with Business Management, being awarded the Jelf Medal<sup>13</sup> as the leading student in his class. He is currently working towards his Ph.D. in the field of Medical robotics and Minimally Invasive Surgery at King's College London. His research is carried out in the Centre for Mechatronics and Manufacturing Systems in collaboration with the Urology Department of Guy's Hospital, London.

*David Noonan*

David Noonan received the B.Eng. degree in Mechatronic Engineering from Dublin City University, Ireland in 2005. In 2006, he was awarded the M.Sc. in Mechanical Engineering Research with Distinction from King's College London, UK. He is currently pursuing a Ph.D. at Imperial College London. His research focuses on the dynamics of tool-biological tissue interaction for medical applications and robotic devices to provide enhanced imaging and sensing during minimally invasive surgery.

*Lakmal D Seneviratne*

Lakmal Seneviratne is a Professor of Mechatronics and the Director of the Centre for Mechatronics at King's College London. His main research focus is the control of complex mechatronic systems interacting with external environments. He is a Fellow of the IET and IMechE and a member of the IEEE.

---

<sup>13</sup> Named for Richard William Jelf, Principal of King's College London from 1844 to 1868, the Jelf Medal is awarded to the student who, in the view of the Principal, has most distinguished themselves during their undergraduate career in the College.

## **Chapter 11 – Intelligent Prosthesis – a Biomechanics Approach**

*Abbas Dehghani*

Abbas Dehghani is a Senior Lecturer in the School of Mechanical Engineering in the University of Leeds where he is responsible for Mechatronics and Robotics research and teaching. His research interests lie mainly in the areas of bioMechatronics and bioRobotics. These include research in distributed smart sensors, actuators, machine intelligence and control, and biologically inspired systems with particular interest in locomotion. Applications cover a wide range, such as medical devices, healthcare and assistive technologies.

## **Chapter 12 – Education in Mechatronics**

*Vladimir Vantsevich*

Dr. Vladimir Vantsevich is a Professor in Mechanical Engineering and the founding Director of the Master's of Science in Mechatronic Systems Engineering Program at Lawrence Technological University, Michigan. He is also a co-founder and the Associate Director of the Automotive Engineering Institute. Prior to joining Lawrence Tech, Dr. Vantsevich was a Professor and the Head of Research and Design Group on Multi-Wheel Drive Vehicles that designed and developed a number of mechatronic and mechanical driveline systems for various purpose vehicles in Belarus. He earned his Ph.D. and DSc (the highest degree in the former USSR) degrees in Automobile and Tractor Engineering from Belarusian National Technical University.

Prof. Vantsevich's research interests have focused on inverse and direct dynamics, on mechanical and mechatronic system modelling, design and control with applications to autonomous and conventional vehicles, driveline and locomotion systems. He is the author of four technical books and more than 100 research papers on inverse/direct vehicle dynamics, vehicle performance optimisation and control, and driveline systems design. Prof. Vantsevich delivered more than 110 science seminars, invited lectures and technical presentations at academic institutions and to industry audiences. He is also a registered inventor of the USSR, holding 30 certified inventions.

Prof. Vantsevich is an Associate Editor of the *International Journal of Vehicle Autonomous Systems* and the *International Journal of Vehicle Noise and Vibration*. He is a member of the Editorial Board of the *Journal of Multi-body Dynamics* (Part K of the Proceedings of the Institution of Mechanical Engineers).

He is a Fellow of ASME, a member of the Association of Vehicle Autonomous Systems International, SAE, International Society for Terrain-Vehicle Systems, and International Association for Vehicle System Dynamics.

## **Chapter 13 – Mechatronics Education**

### *Job van Amerongen*

Job van Amerongen studied Electrical Engineering at Delft University of Technology. From 1973–1987, he was assistant and then associate professor at Delft University of Technology where he worked on applications of modern control theory, especially model reference adaptive control in ship control systems and electrical power production systems. Since 1987, he has been a professor in Control Engineering at the University of Twente.

In 1989, he co-founded and chaired the Mechatronics Research Centre Twente. From 1994–1998, he was dean of the Faculty of EE and from 1998–2006, the scientific director of the Drebber Institute for Mechatronics. Since 2005, he has been head of the department of EE in the faculty of Electrical Engineering, Mathematics and Computer Science (EEMCS). He is a member of the IFAC Technical Committee on Mechatronics, the IFAC TC on Marine Systems and an international member of the Mechatronics Forum in the UK.

At present, he is a member of a team that works on a new curriculum regarding "Creative Technology" at the University of Twente. Current research interests are applications of intelligent control in mechatronic systems, modelling and simulation and embedded control systems. He is the author of many papers on adaptive and intelligent control, mechatronics and the automatic steering of ships, co-author of a book on adaptive control systems and author of three courses on systems and control of the Dutch Open University.

## **Chapter 14 – A Personal View of the Early Days of Mechatronics in Relation to Aerospace**

### *Bill Scarfe MBE*

William Scarfe spent most of his working life employed in the aircraft industry. In 1967, he was invited to form a development laboratory to support newly evolving avionics systems. Previously, he had been involved with more mechanical systems such as weapons, rockets and ballistic stores, i.e., bombs.

The advent of avionics provided the opportunity to become involved with this latest technology. An invitation to establish development laboratories to support avionics was readily accepted. At the time, knowledge on that topic was extremely limited and of necessity, the task was one of trailblazing, an all too rare an opportunity. He continued in this job until retiring from his position as Chief of Engineer Systems Development. During this period, the job had expanded to include all systems on the aircraft and also provided the interest in mechatronics.

During the latter part of his career, he was invited to work at Lancaster University to provide an industrial input to ongoing work on systems research within the engineering department. A liaison was quickly formed with David

Dawson<sup>14</sup> and David Bradley<sup>15</sup>, resulting in his involvement in the Mechatronics Forum. Eventually, he was invited to become an industrial member of the Science and Engineering Research Council where he became a spokesman for Mechatronics.

---

<sup>14</sup> The author of Chapter 3

<sup>15</sup> Now Prof. David Bradley and one of the editors of this book