

# Aalto University

# *School of Engineering*

MEC-E2004 Ship Dynamics (L)

## Course Introduction

# The ship design spiral

Where do ship dynamics fit in ?

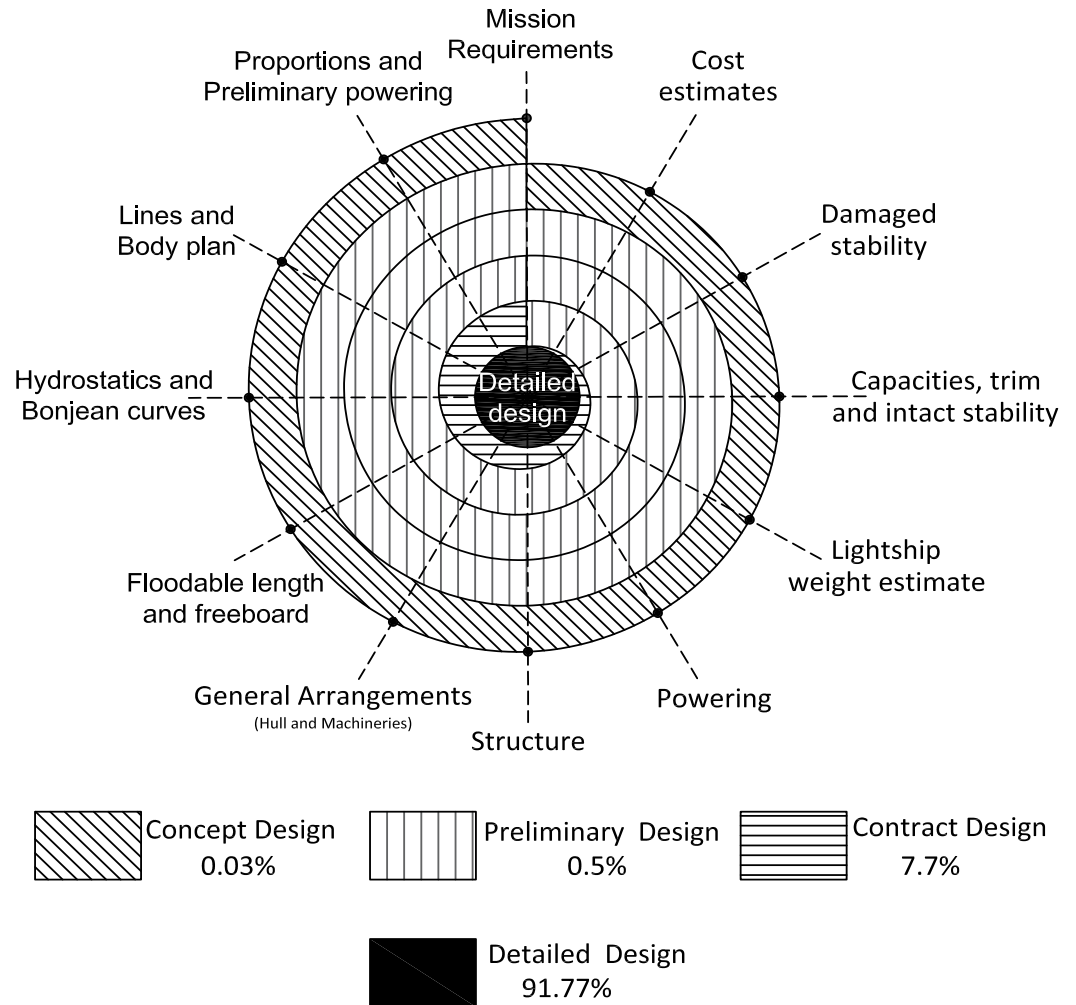

# Course introduction

- Ship dynamics is an essential part of ship design. Some topics of relevance are :

- Seakeeping
- Manoeuvring and directional control
- Added resistance
- Ocean Waves
- Dynamic stability

- This course focuses on seakeeping, manoeuvring and some elements of resistance/propulsion.

- There is strong emphasis on hydro-mechanics and ship design

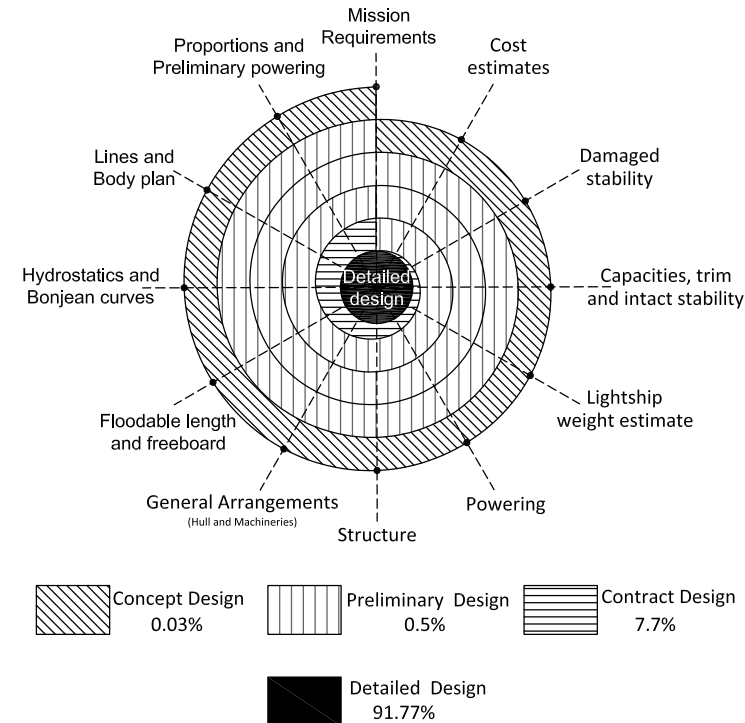

# Course introduction

- NAPA and MAXSURF computations are partly supported
- The limits of various analyses are discussed
- We will touch upon numerical methods for wave modelling, ship motions, loads, directional control
- However, further post-graduate studies may be necessary to understand fully the concepts discussed

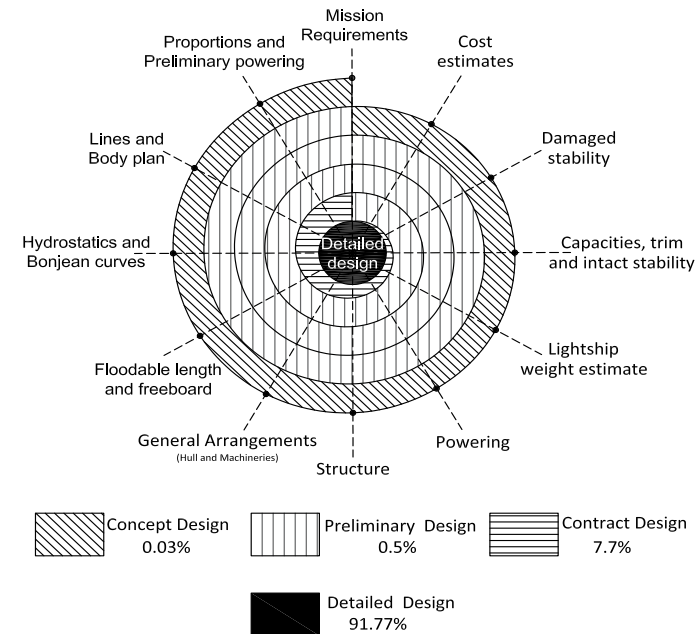

# Related Maritime Tech - MSc Courses

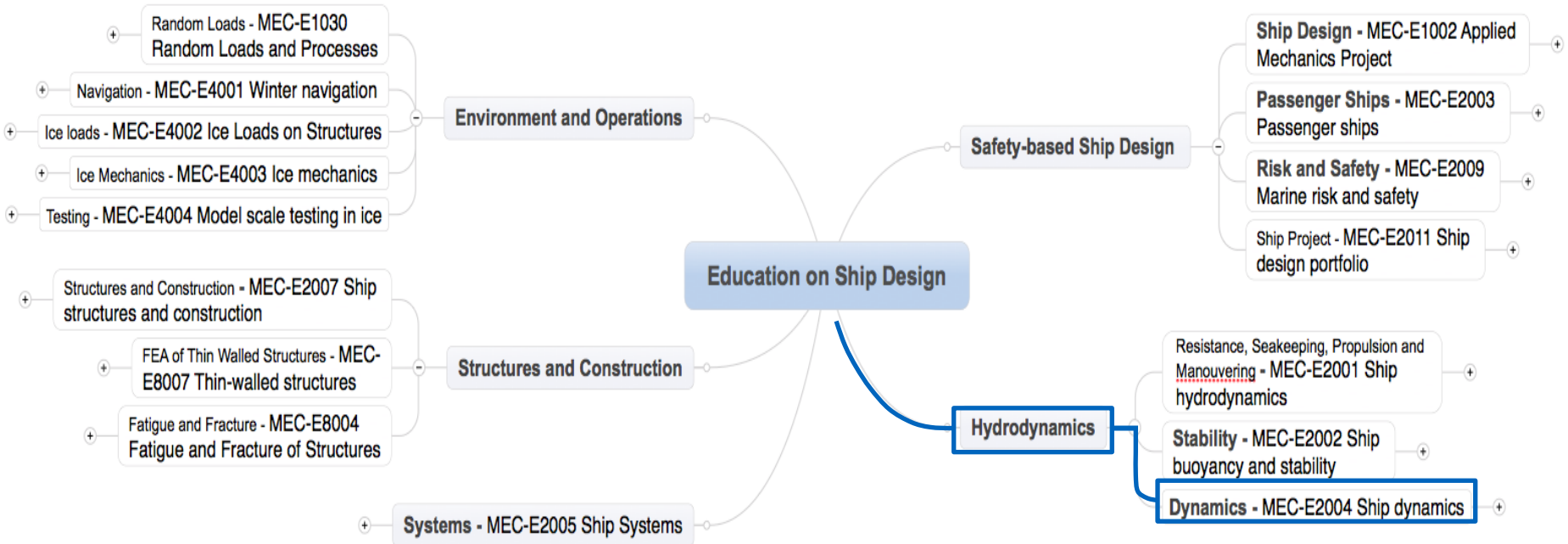

# Related Maritime Tech - MSc Courses

- **PNA & Ship Design Portfolio**
  - Input : Design principles, ship knowledge, and NAPA
  - Output : Concept ship design
- **Ship Structures and Construction**
  - Input: loads for structural design
  - Output: weight and weight distributions
- **Fluid Mechanics**
  - Input: potential flow theory
  - Input: CFD
- **Dynamics of Rigid Bodies**
  - Input: equations of motion
  - Input: solution techniques for equation of motion in time and frequency domains
- **Random Loads and Processes**
  - Input: spectral treatment of random loading
  - Input: statistical prediction of short and long term loads and responses



# Where is this lecture on the course ?

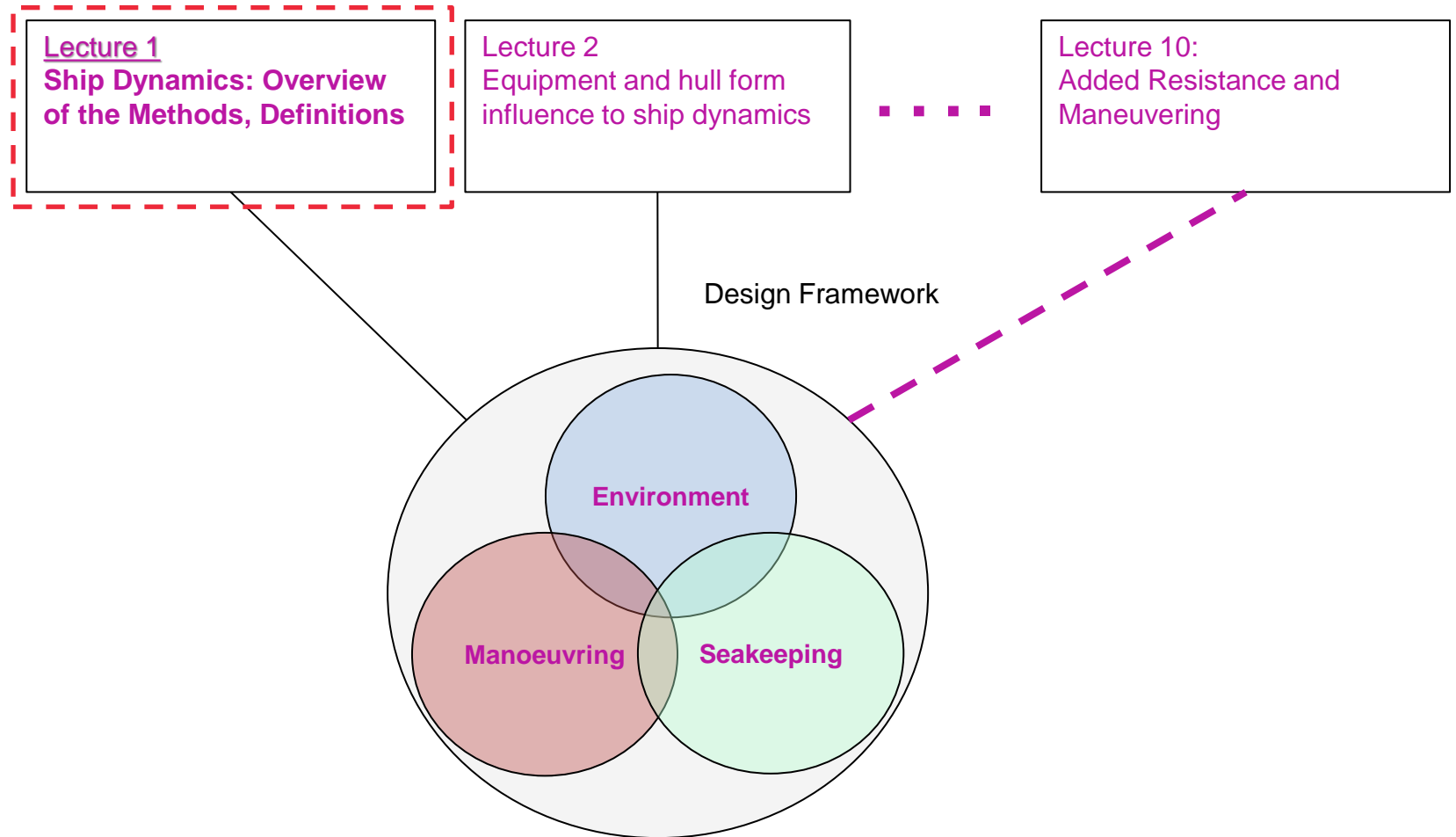

# Aims of this lecture

*To understand the contents of ship dynamics and most often used assumptions.*

- What do we mean by ship dynamics ?
- Can we recognise key phenomena ?
- What is the role of engineering tools?
- What are the key modelling assumptions?
- Why non-linearities are important?





# Ship Dynamics –Key text books

- **Mycourses:** <https://mycourses.aalto.fi/course/view.php?id=32384&section=1>
- **Course notes to be provided on a weekly basis. Reading and understanding those is important for your development and the course**
- Spyros Hirdaris and Tommi Mikkola (2020). Ship Dynamics for Performance Based Design and Risk Averse Operations, A special issue of Journal of Marine Science and Engineering (ISSN 2077-1312) - [https://www.mdpi.com/journal/jmse/special\\_issues/ship\\_dynamics](https://www.mdpi.com/journal/jmse/special_issues/ship_dynamics)
- Prof. Jurek Matusiak, Dynamics of a Rigid Ship with applications, Aalto University Aalto University publication series on Science and Technology; 4/2021, ISBN978-952-64-0399-1, <https://aaltodoc.aalto.fi/handle/123456789/108000>

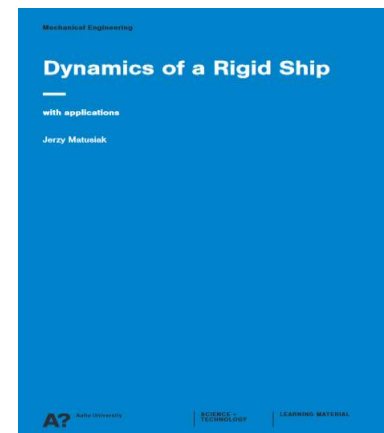

# Key topics

- What are the definitions of the following ship dynamics terms?
  - ✓ Seaworthiness
  - ✓ Seakeeping
  - ✓ Sea loads
  - ✓ Added resistance
  - ✓ Ship directional control
  - ✓ Ship manoeuvrability
  
- **What is the difference between seaworthiness and seakeeping?**
  
- **How ship dynamics influence design development, approval and safety ?**



# What is the difference between statics & dynamics ?

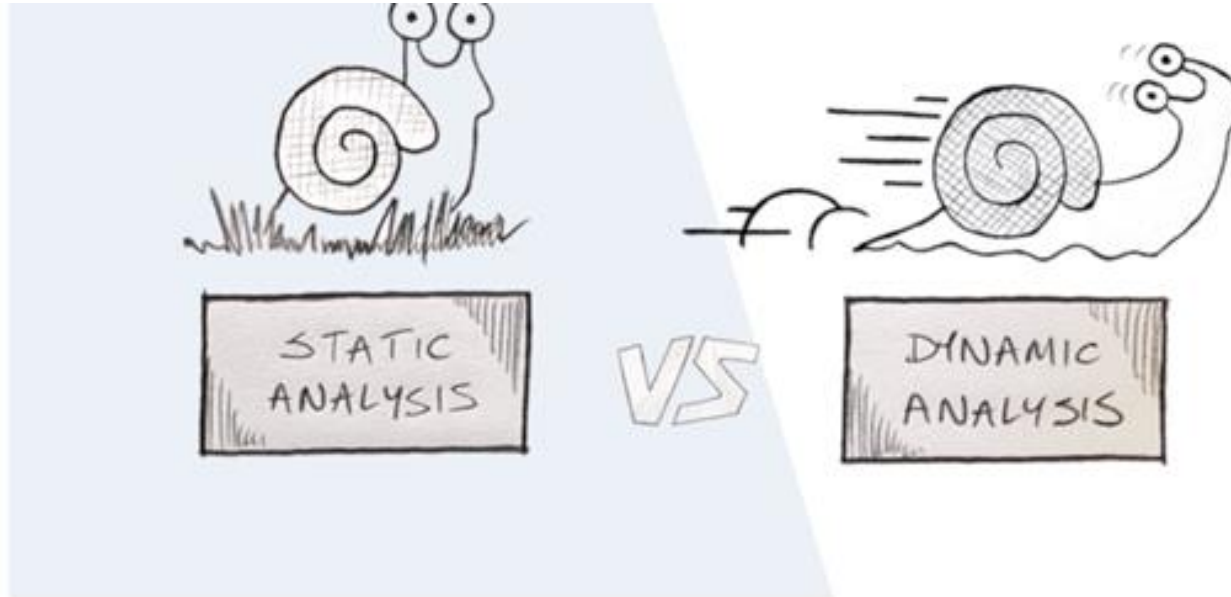

# Ship Dynamics – An Extensive Subject

- All operational conditions of a vessel where **inertial forces** play a role are important
- We consider all situations that differ from:
  - ✓ Ideal still water condition
  - ✓ Constant heading
  - ✓ Constant forward speed
- Common model simplifications are used for the following phenomena:
  - ✓ Ocean waves
  - ✓ Hydroelasticity
  - ✓ Added resistance in waves
  - ✓ Structural vibrations
  - ✓ Seakeeping & Manoeuvring
  - ✓ Stability (intact, damage, static/dynamic)

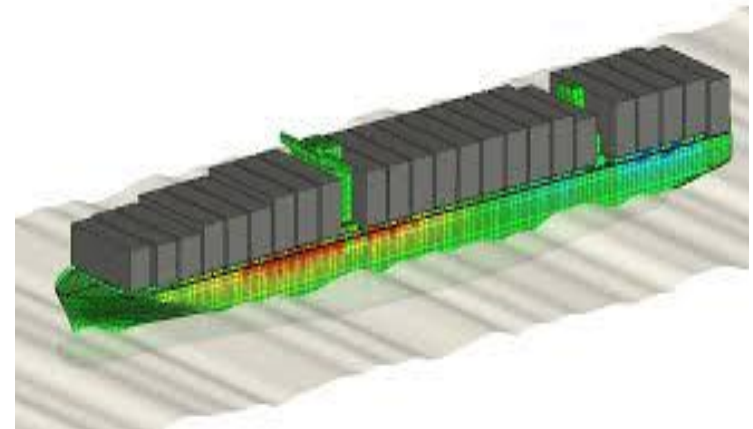

# Ship dynamics for safety

- **Safety in design**
  - Assured by Classification society Rules
    - ✓ LR; ABS; DNV
    - ✓ Develop rules on ship loads
    - ✓ Some rules were improved based on accident records, experience and experiments
- **Safety in operations**
  - Assured by the International Maritime Organization (IMO)
    - ✓ Manoeuvring and stability requirements
    - ✓ Fire zones
    - ✓ Flag Administrations, Classification Societies, academia and industry helped a lot in developing these rules
- **New technology (CFD, FEA..) can be used for optimization and validation of the new ideas**



# What is seaworthiness ?

*“The general term of seaworthiness must embrace all those aspects of ship design that affect her ability to remain at sea in all conditions and carry out her specified duty”, Basic Ship Theory (Rawson and Tupper), Chapter 12*

## ➤ Ship operation and functions

- ✓ Deck operations and equipment
- ✓ Wetness on deck might need increase in freeboard
- ✓ Repair of structures exposed to unexpected water
- ✓ Slamming causing high stress to ship structures such as hull girder
- ✓ Operational limits for ship to avoid excessive motions, capsizing, propeller racing

## ➤ Crew and passenger safety

- ✓ Falling and man-overboard
- ✓ Motion sickness, fear

## ➤ Mission safety

- ✓ Ship resistance increased by wave motion
- ✓ Interaction between ship motion and speed reduction
- ✓ Route optimization for minimal fuel or transport time?

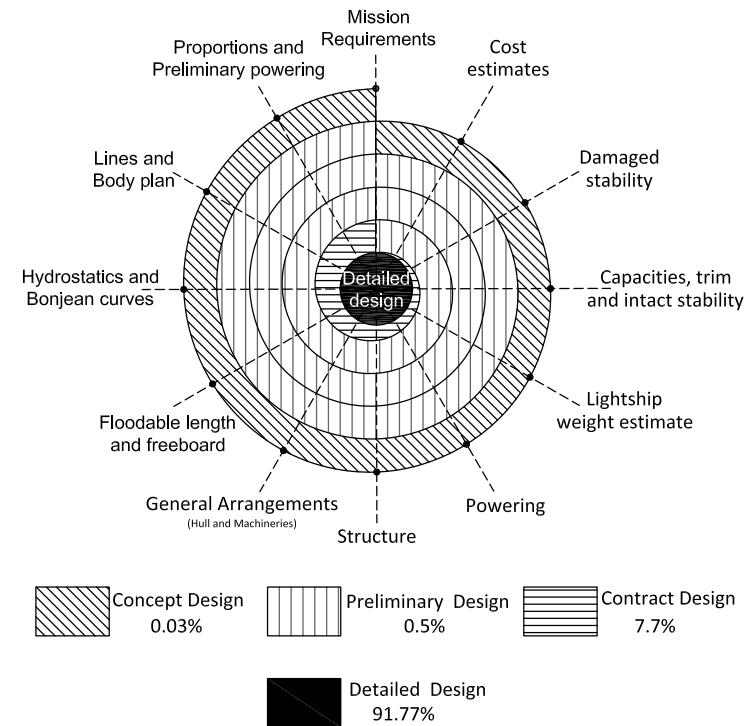

# Definition of seakeeping

*Good seakeeping is desirable feature, but we need to compromise with each ship's special design features and dynamics. Those may be related with the appendages, cargo, lifting equipment etc. Typical design process: design, tests, redesign, test etc....*  
**Simulations shorten the numbers of iterations in design.**

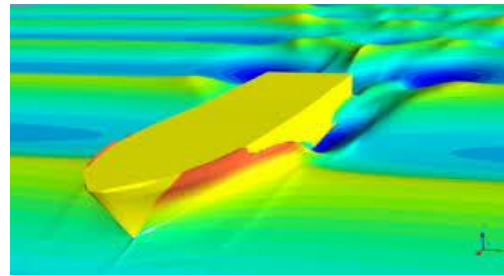

[https://www.youtube.com/watch?v=atk4\\_KsxV6s](https://www.youtube.com/watch?v=atk4_KsxV6s)

# Ship manouvering and directional control

*A ship is directionally stable if a deviation from a set course increases only while an external force or moment is acting to cause the deviation. Neither stability or instability obviates the need for devices to maintain a course or to change it on command.*





# Assignment 1

## ➤ Grades 1-3

- ✓ Select a paper related to ship dynamics and read it
- ✓ Define the operational profile for your ship, operations including seasonal effects and ship dynamics requirements
- ✓ Define the shape, size, location and space reservation of the maneuvering devices of your ship and sketch them on top of your hull
- ✓ Describe the main features of your ship's hull form that affect the ship dynamics

## ➤ Grades 4-5

- ✓ Read 1-2 scientific journal articles related to ship dynamics
- ✓ Reflect these in relation to knowledge from books and lecture slides

## ➤ Report and discuss the work

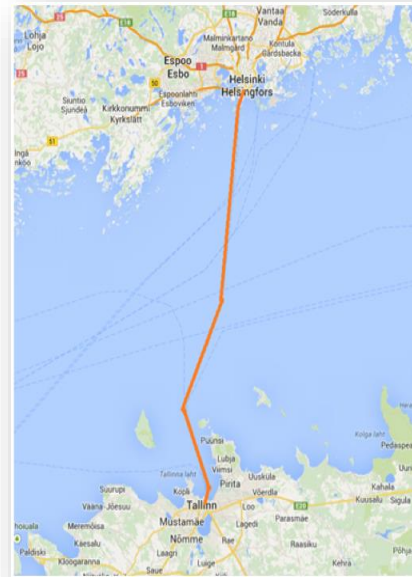

Baltic Sea

- 9 months in open water
- 3 months in ice
- X trips per day/week
- Y speed
- Z cars and ZZ busses
- ...

Ice loads affect in-plane motions  
Parametric rolling possible due to aft shape  
Slamming due to bow shape

Any other relevant info for Ship dynamics, such as

- Moving cargo
- ...

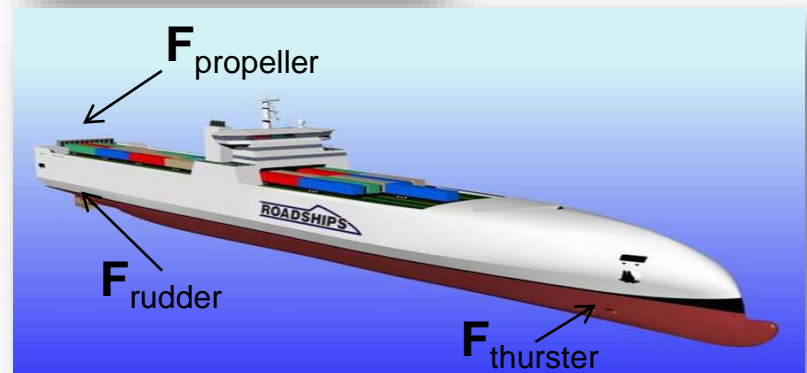

# Seakeeping demands

- Prediction of motions/loads in irregular seas
  - ✓ Scatter diagram for wave conditions
  - ✓ Wave spectra for energy contents
  - ✓ Response amplitude operator for responses
- Frequency domain linear models allow for
  - ✓ Representation of natural seaway as superposition of regular (harmonic) waves and Fourier decomposition
  - ✓ Determination of ship responses
  - ✓ In most cases this model gives a sufficiently accurate prediction of loads and ship motions
- Linear models cannot predict loss of ship stability in waves, parametric roll resonance or asymmetry of sagging/ hogging wave loads
- Ship steering and maneuvering motion are also often disregarded

Table 5—Observed Percentage Frequency of Occurrence of Wave Heights and Periods (Hogben and Lumb data)

Wave height, m	Northern North Atlantic										Total
	Wave Period $T_1$ , sec										
	2.5	6.5	8.5	10.5	12.5	14.5	16.5	18.5	20.5	Over 21	
0-1	13.7204	3.4934	0.8559	0.3301	0.1127	0.0438	0.0249	0.0172	0.0723	0.3584	19.0291
1-2	11.4889	15.5036	6.4817	1.8618	0.5807	0.1883	0.0671	0.0254	0.0203	0.0763	36.2941
2-3	1.5944	7.8562	8.0854	3.7270	1.1790	0.3713	0.1002	0.0321	0.0091	0.0082	22.9629
3-4	0.3244	2.2487	4.0383	2.9762	1.3536	0.4477	0.1307	0.0428	0.0050	0.0040	11.5724
4-5	0.1027	0.7838	1.6998	1.5882	0.9084	0.3574	0.1443	0.0433	0.0072	0.0049	5.6400
5-6	0.0263	0.1456	0.3749	0.4038	0.2493	0.1200	0.0382	0.0067	0.0027	0.0027	1.3702
6-7	0.0277	0.1477	0.3614	0.4472	0.2804	0.1301	0.0564	0.0113	0.0011	0.0032	1.4605
7-8	0.0084	0.0714	0.1882	0.2199	0.1634	0.0785	0.0353	0.0069	0.0018	0.0034	0.7772
8-9	0.0037	0.0325	0.0856	0.1252	0.1119	0.0558	0.0303	0.0045	0.0027	0.0033	0.4555
9-10	0.0034	0.0204	0.0674	0.1173	0.0983	0.0550	0.0303	0.0173	0.0079	0.0047	0.4220
10-11		0.0005	0.0012	0.0023	0.0031	0.0012		0.0005			0.0088
11+		0.0005	0.0007	0.0019	0.0035	0.0002			0.0005		0.0073
Totals	27.3003	30.3043	22.2415	11.8009	5.0143	1.8493	0.6517	0.2080	0.1306	0.4691	100.000

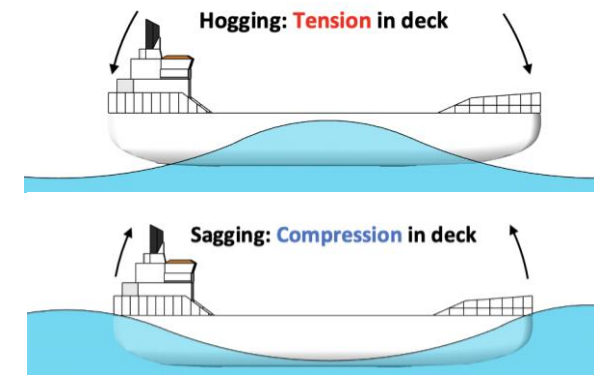
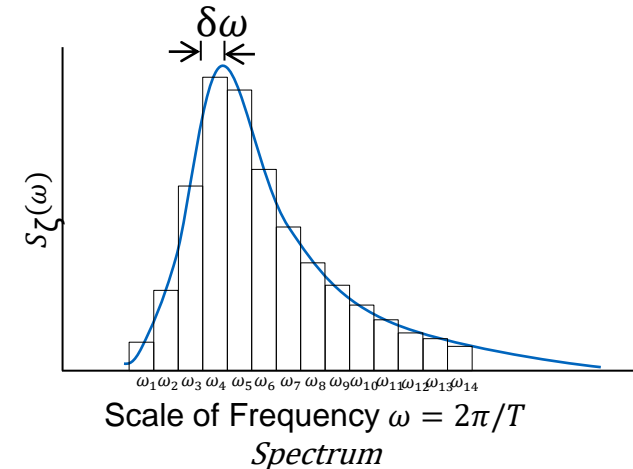

# Seakeeping – a practical example

## How important are deck openings?

- Relation of ship motions and impact to deck feature behaviour:
  - ✓ P. Ruponen, J. Matusiak, J. Luukkonen, M. Ilus. (2009). Experimental Study on the Behavior of a Swimming Pool Onboard a Large Passenger Ship. Marine Technology, Vol 26, No. 1: pp. 27-33.
  - ✓ [YouTube link](#) : See What Happens to a Cruise Ship Pool in Rough Seas (10 sec)

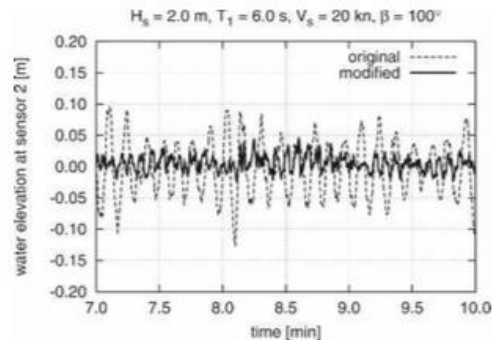
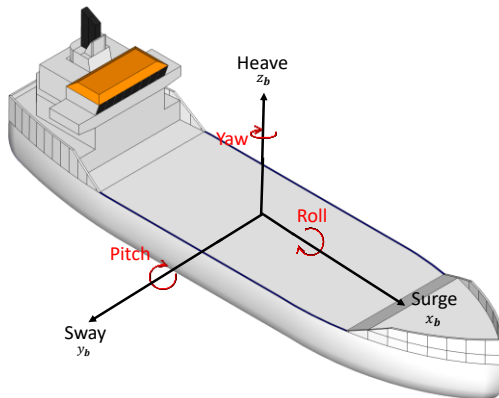

Fig. 19 Example of the wave elevations at sensor 2 for the original and modified pools in the normal sea state

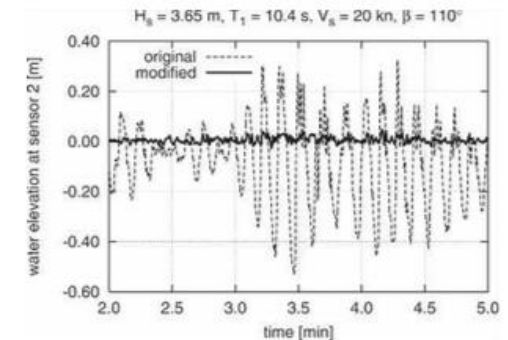

Fig. 20 Example of the wave elevations at sensor 2 for the original and modified pools in the harsh sea state

# Ship manoeuvring

- Design aspects to consider:
  - Course-keeping and course-changing
  - Track-keeping
  - Speed-changing
  - Directional stability & control
  - *Manoeuvring requirements affect the selection of rudders/pods, waterjets, fixed fins, jet thrusters, propellers, ducts, steering nozzles, etc.*
- Concerns of shipyard v. shipowner
  - IMO sets minimum requirements for all ships (IMO A751)
  - Ship-owners may be much more strict (e.g. port of Miami)

## ➤ **Practical Questions:**

- ✓ *Does the ship keep a straight course on her own?*
- ✓ *Is tug assistance needed to berth? With wind speeds?*
- ✓ *Could the vessel initiate/sustain/stop turning?*
- ✓ *Could the vessel stop and accelerate safely?*

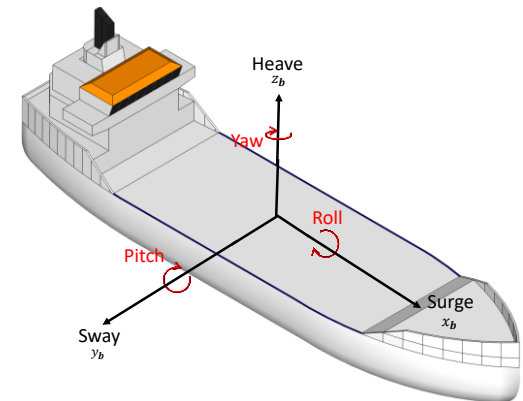

# Manoeuvring vs Seakeeping models

## ➤ Manoeuvring models

- Time dependent investigations are typical
- Studied in shallow waters
- Inertial coordinate system
- Viscosity is usually considered

## ➤ Seakeeping models

- Time dependent investigations optional
- Studied in open seas
- Fixed coordinate system
- Viscosity is usually neglected or superimposed due to mathematical difficulties and cost of simulation

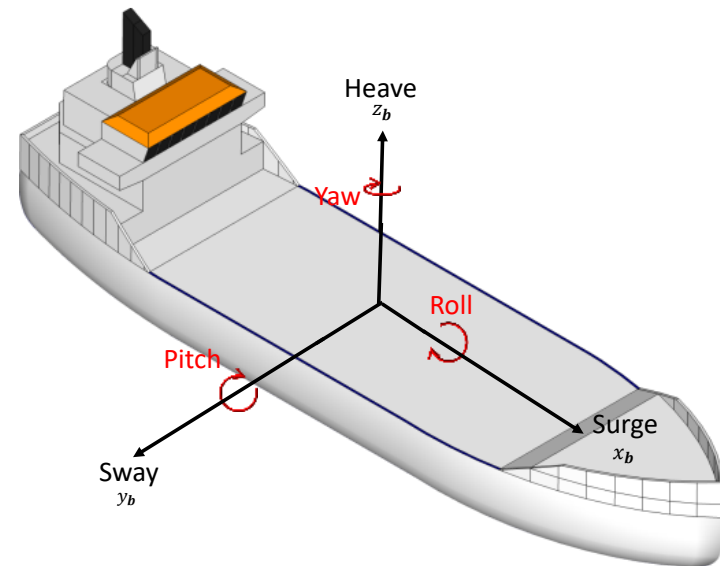
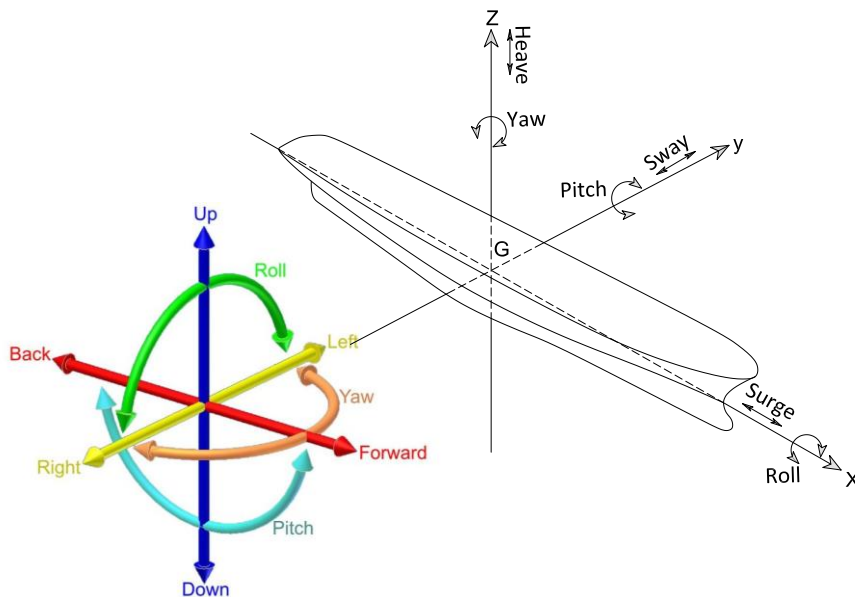

# Wave Loads

- Static, still water and wave loads
- Quasi static, dynamic and hydroelastic methods
- Hydroelasticity refers to the situation where the hull deformations and flow-field interact strongly, i.e. the problems cannot be decoupled
- Required in cases where the hull is slender, flexible and has large deck openings (e.g. large containerships)
- Simulations involve coupling of seakeeping hydrodynamics

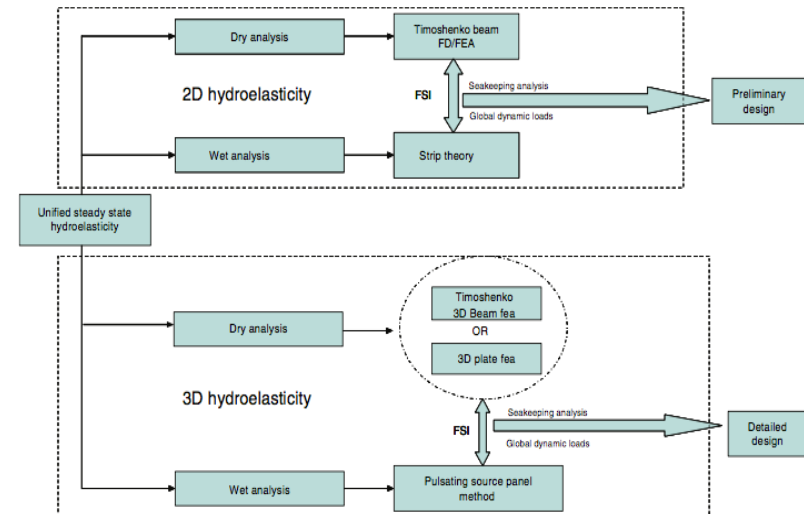
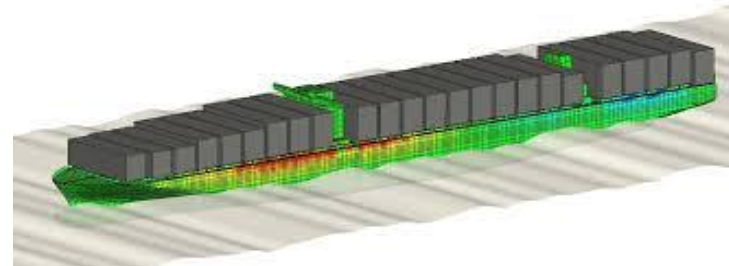

# Dynamic stability in waves – some issues

- **Dynamic stability in waves**
  - Investigates roll motions in the irregular seaway
  - Nonlinear analysis for roll damping
- **Ship survivability against capsizing**
  - Ensures the ship will not capsize in severe waves of different directions, periods and amplitudes
- **Resonant or breaking waves in beam seas**
  - Waves approach from side
  - Excite large rolling may lead to capsizing, especially if it is accompanied with cargo shift, or green water on deck
- **Breaking waves in following-seas**
  - Pure loss of stability
  - Parametric instability
  - Broaching to

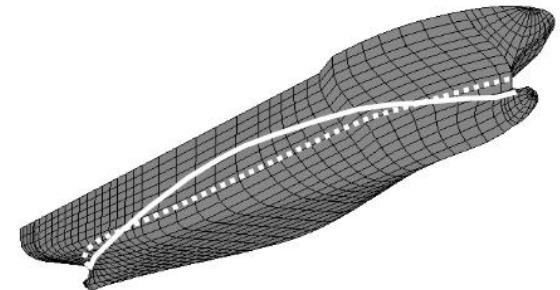
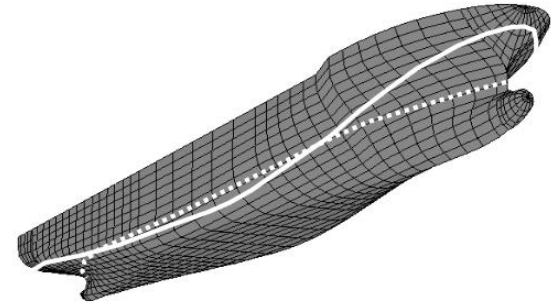

# Example – broaching to

**Broaching to** relates to an unintentional change in the horizontal-plane kinematics of a ship. Broadly, it may be described as the “*loss of heading*” by an actively steered ship. It is accompanied by an uncontrollable build-up of a large deviation from the desired course. Broaching to is more commonly occurring in following seas and propagate in a direction forming a small angle, say 10-30 deg., with the longitudinal axis of the ship

- (a) The ship may run on crest
- (b) ship stern gets too high and thus the rudder loses effect
- (c) the bow pitches into trough and buries
- (d) stern swings round bringing ship abeam to elements
- (e) next wave will possibly break over the ship and cause severe damage

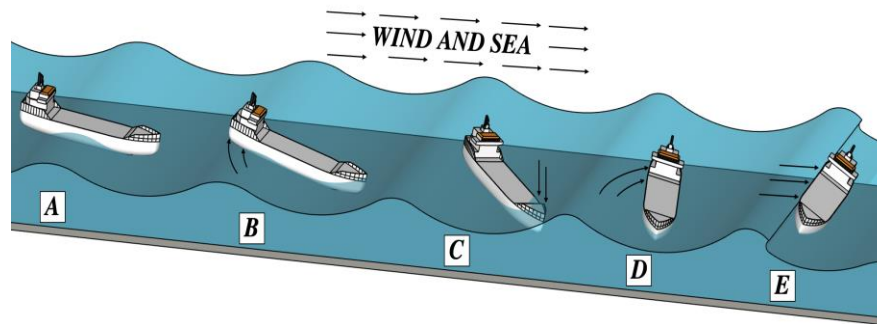



# Engineering methods

- Experimental approaches in model- or full-scale are used for
  - ✓ Validation
  - ✓ Special investigations on safety
  - ✓ Manoeuvring tests to define the coefficients in EoM
- Numerical methods
  - ✓ Strip theories, panel methods, CFD methods
  - ✓ Manoeuvring simulations using experimental coefficients (CFD can be used to reduce scaling errors)
  - ✓ Computations in Frequency domain, e.g. ship responses for harmonic waves in different wave directions and lengths
  - ✓ Computations in time domain, i.e. motions and forces in given point of space and time
  - ✓ Computations in statistical domain: statistically significant seakeeping values in irregular (natural) seaways

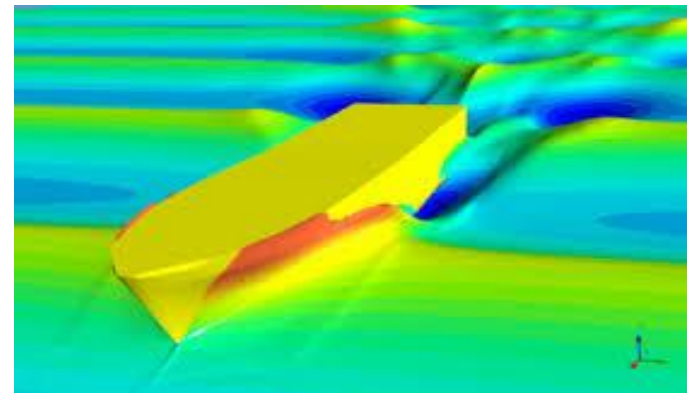

# Ocean basins

- Commonly called tow tanks
  - [YouTube link](#) : UBC Ocean Engineering Centre Tow Tank Test 3 (20 sec)
  - [YouTube link](#) : Propulsion test in a towing tank (1 min 56 sec)
  - [YouTube link](#) : Towing Tank Test (44 sec)

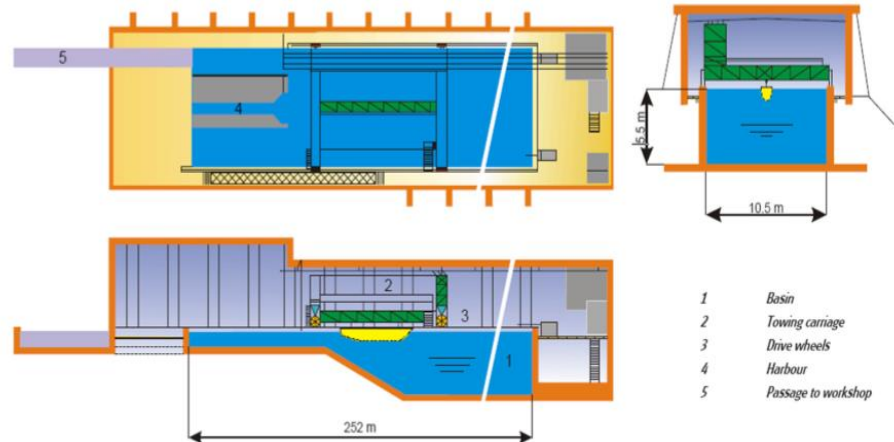
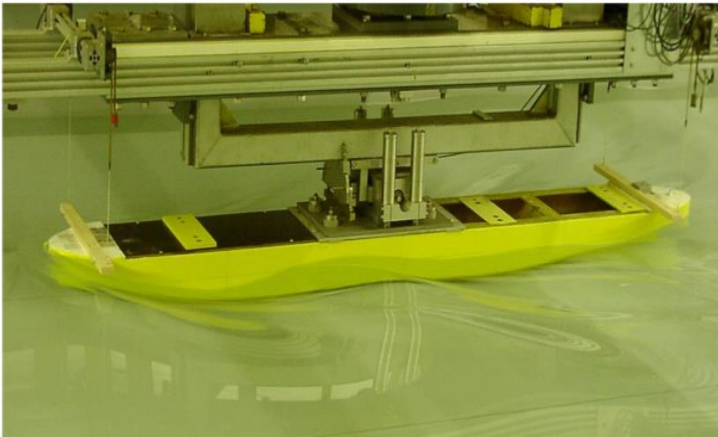

# Model experiments

- Self-propelled models are used to avoid any extra reactions
- Remote control, autopilot, sometimes wires are used to restrain some DOF
- Models may be sectional if wave loads are measured, moment gauge between sections
- Expensive approach as water needs to settle between tests and models costs
- Many parameters can be changed: Froude similarity is key
- Scaling issues : slamming with viscous effects, water on deck, effects are not as important in seakeeping as in resistance, propulsion or manoeuvring

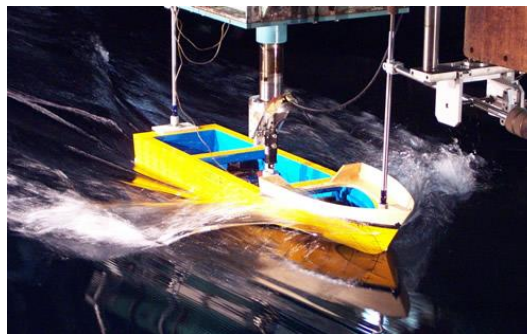
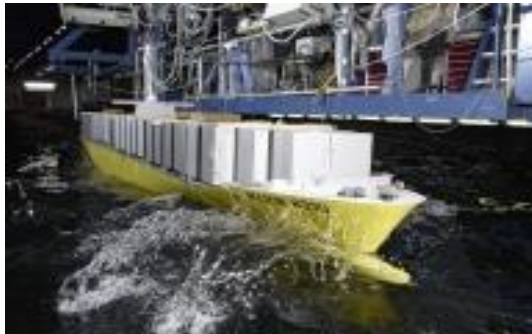

# Example : Segmented model experiments

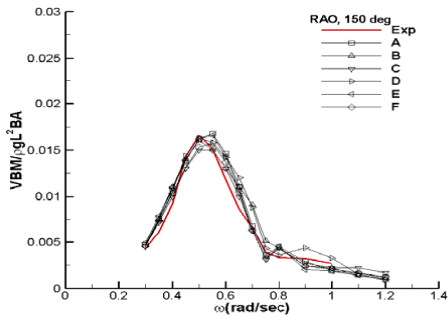
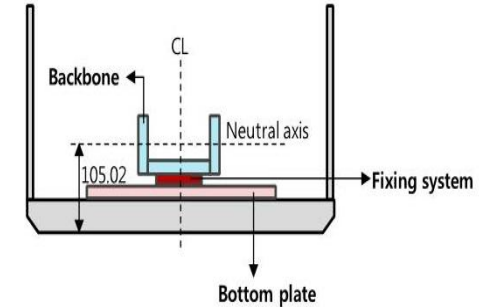
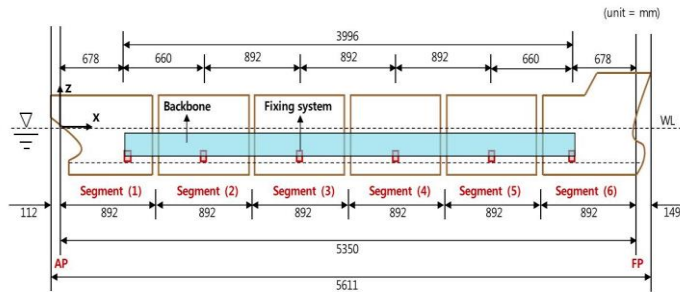

15 Force sensors  
(CURIOTEC CSBA-S, 10 kgf)

1 Pressure sensor  
(KISTLER 4005B, 5 bar)

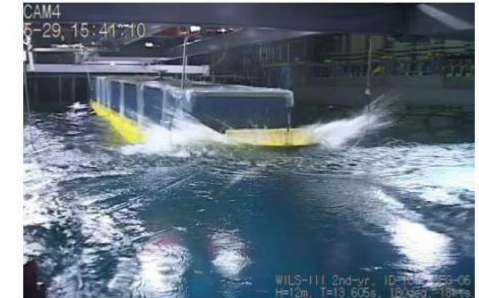

[YouTube link](#): Ropax Ferry RV1500GT Seakeeping Test at Indonesia Hydrodynamic Laboratory (27 min 24 sec)

# Full Scale Measurements

Ships can be assembled with gyros, strain gauges etc. to measure the responses

- Accelerometers for motions
- Strain gauges to extract wave bending moments
- Loss of speed, propeller rpm and torque are also measured
- Uncertainties relate with accurate seaway measurements and measurement equipment failures

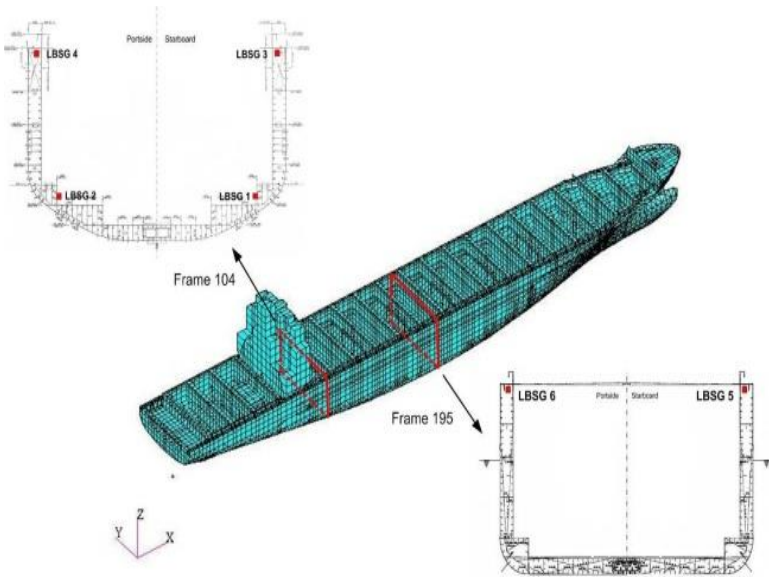

## Example for sensor arrangements

4600 TEU Container Ship

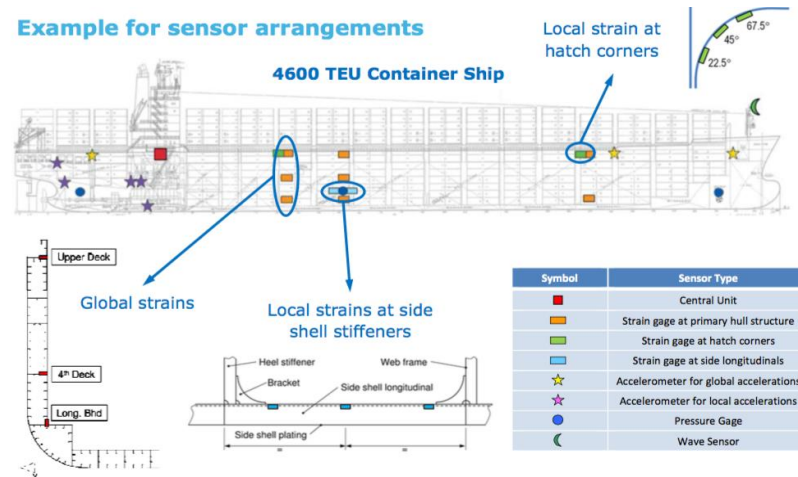

# Simulation methods

- Most common approach is to measure loads and responses in time. This involves:
  - ✓ Integration of velocities and motions
  - ✓ Fourier transformation to evaluate spectra in frequency domain (e.g. FFT)
- To achieve the above we need to identify the motions and significance of non-linearity. Often we consider two types of analyses
  - ✓ Screening in frequency domain: what are the worst conditions for our ship?
  - ✓ Simulations in time domain: when wave-amplitude dependency is violated, what is the impact?
- Different methods contain different **assumptions on stochastics** of the problem and fluid idealisations. Examples are :
  - ✓ Navier-Stokes, i.e. full CFD
  - ✓ Reynolds-Averaged Navier-Stokes where little turbulence fluctuations are omitted in boundary layers
  - ✓ Euler equations where viscosity is neglected and coarser meshes are used for faster simulations
  - ✓ Potential flow solvers where the flow is usually irrotational and we cannot model breaking waves or splashes

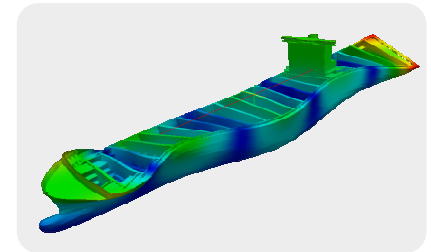
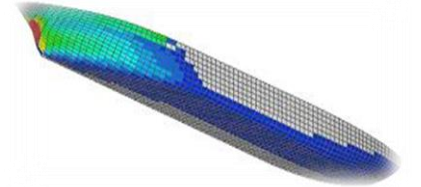
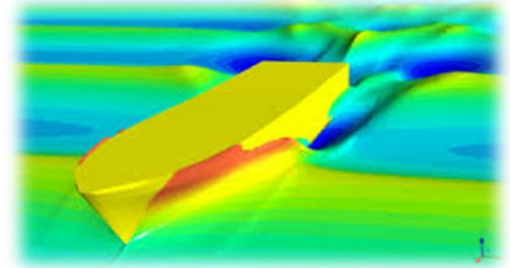

# Simplified hydro-analysis assumptions

- Small wave amplitudes
- Rigid hull
- Potential flow; no viscosity or compressibility - fluid flow rotation inviscid
- Wave dynamics are modelled by 3 translations & 3 rotations. Roll & pitch are dynamic equivalents to heel and trim. Translations in x- and y-axis and rotation around z-axis will not result in residual force or moment if ship displacement remains constant. For other movements forces and moments may be necessary.

*The above assumptions do not hold in large waves, higher speeds, slender hulls,  
AND  
extreme scenarios (e.g. freak waves, groundings, collisions)*

# Why Non-Linear hydrodynamics ?

- ❑ Most applications use potential flow
- ❑ Ad-hoc codes use partly NL methods
- ❑ Fully NL & RANS solvers not mature
- ❑ Modelling & use in design not verified

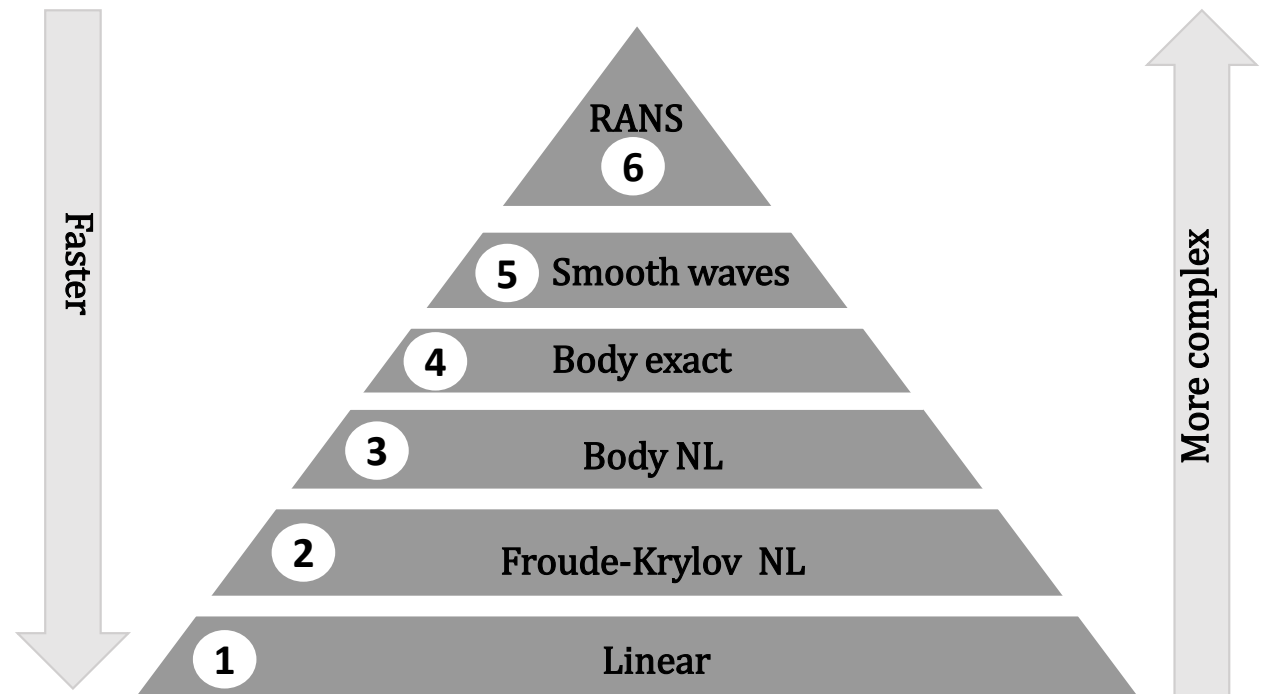



# Non-Linear Hydrodynamic applications

- Ship motions are not linearly proportional to wave amplitude and period and **in large waves the NL effects are amplified**
- Important topics to understand:
  - ✓ Statistics of large waves
  - ✓ Non-linear wave theory
  - ✓ Non-linear model for advanced ship-handling
  - ✓ Time domain simulations for motions/loads/stability
  - ✓ Ship hydroelasticity under intact and damage conditions
- Other example cases to understand:
  - ✓ Capsizing
  - ✓ Sagging and hogging moment ratios
  - ✓ Parametric roll, broaching
  - ✓ Slamming (bow, bottom, stern)
  - ✓ Maneuvering in confined waters
  - ✓ High speed craft motions and loads



## Sagging & Hogging on Waves

### • Sagging condition

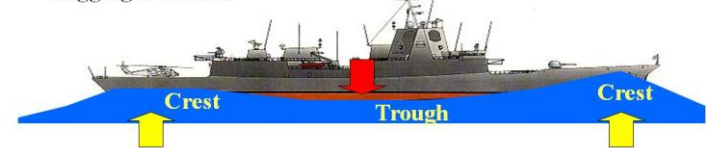

### • Hogging condition



# Further examples (Review at Home)

- Parametric roll tests are primarily concerned with **dynamic stability** : [YouTube link](#) (1 min 55 sec)
  - ✓ Loss of stability on a crest of a following wave
  - ✓ Parametric roll resonance
  - ✓ Regular and irregular waves
    1. Head and following waves
    2. Varied amplitude
  - ✓ Simulations indicate that below a certain wave amplitude there is no parametric roll resonance
- Ship Dynamics in Shallow Waters : [YouTube link](#) (9 min 20 sec)
- Accidental loads: [YouTube link](#) (8 min 50 sec)
- Bank Effects Ships in Restricted Waters : [Video link](#) (13 min)

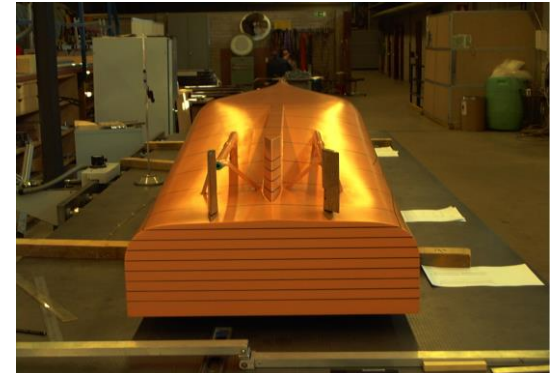

GUIDE FOR THE

**ASSESSMENT OF PARAMETRIC ROLL RESONANCE IN  
THE DESIGN OF CONTAINER CARRIERS**

APRIL 2019

# Summary

- Ship dynamics, performance, and safety go hand in hand
- Model experiments, simulations and full-scale measurements are essential part of the design and validation process
- Ship dynamics relates with
  - ✓ *Seakeeping*
  - ✓ *Maneuvering*
  - ✓ *Wave loads*
  - ✓ *Added resistance, dynamic stability*
- The models can be linear or non-linear, rigid or flexible
  - ✓ *Linear in frequency domain to map the worst-case scenarios*
  - ✓ *Non-linear in time domain to simulate the behavior*
  - ✓ *Flexible to simulate hydroelasticity effects*
- *For next time* : *Refresh your skills and knowledge on ship resistance and propulsion*

# Aalto University

## *Thank you !*

MEC-E2004 Ship Dynamics (L)