

Aalto University

School of Engineering

MEC-E2004 Ship Dynamics (L)

Lecture 2

Controlling Ship Dynamics

Where is this lecture on the course?

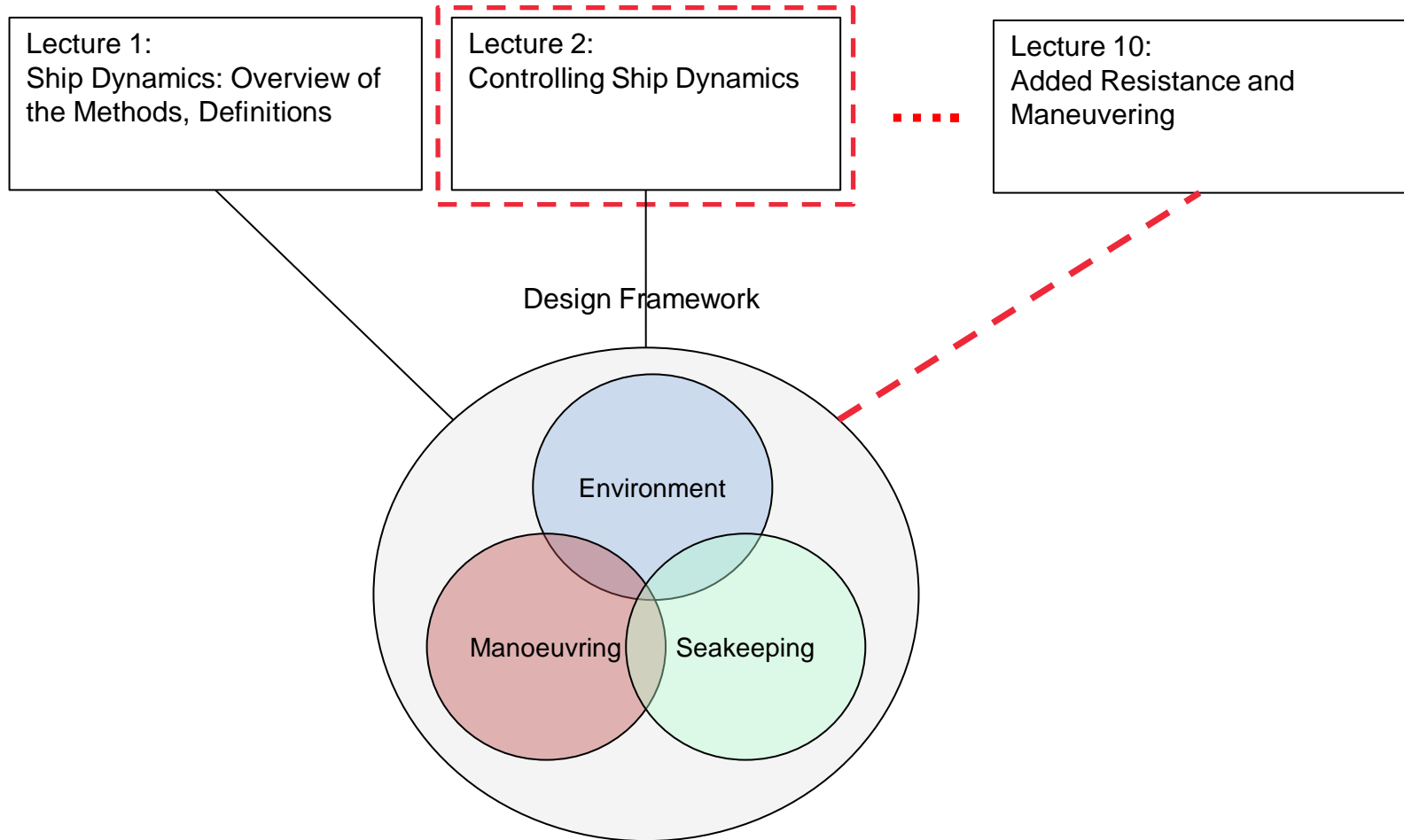

Contents

Aims

- To understand how equipment and hull form affect ship dynamics
- Appreciate the influence of propulsive control systems on ship dynamics and associated design choices.

Some Keywords !

- Rudders, Propellers, Pods, Thrusters
- Bilge keels and stabilizer fins,
- Passive and active tanks
- Hull resistance
- Controlability
- Auto-pilot Systems

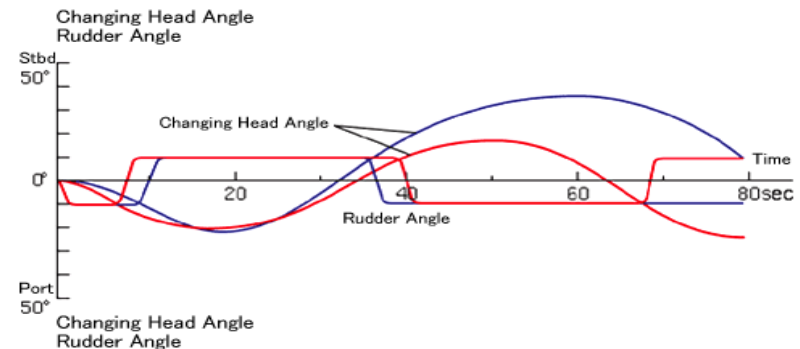

Assignment 1

• Grades 1-3

- ✓ Select a book-chapter related to ship dynamics and read it
- ✓ Define the operational profile for your ship, operations including seasonal effects and ship dynamics requirements
- ✓ Define the shape, size, location and space reservation of the maneuvering devices of your ship and sketch them on top of your hull (Napa-input)
- ✓ Describe the main features of your ship's hull form that affect the ship dynamics

• Grades 4-5

- ✓ Read 1-2 scientific journal articles related to ship dynamics
- ✓ Reflect these in relation to knowledge from books and lecture slides

• Report and discuss the work

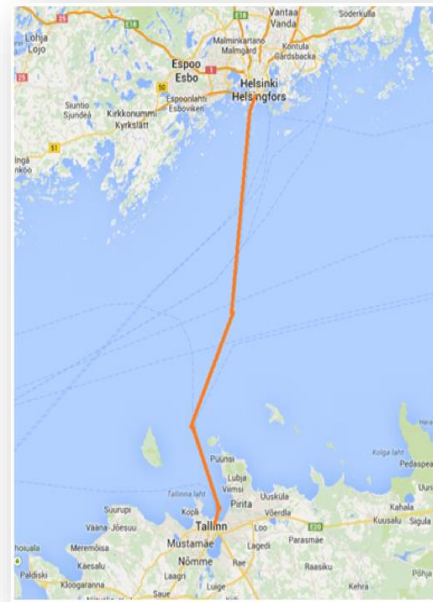

Baltic Sea

- 9 months in open water
- 3 months in ice
- X trips per day/week
- Y speed
- Z cars and ZZ busses
- ...

Ice loads affect in-plane motions
Parametric rolling possible due to aft shape
Slamming due to bow shape

...

Any other relevant info for Ship dynamics, such as

- Moving cargo
- ...

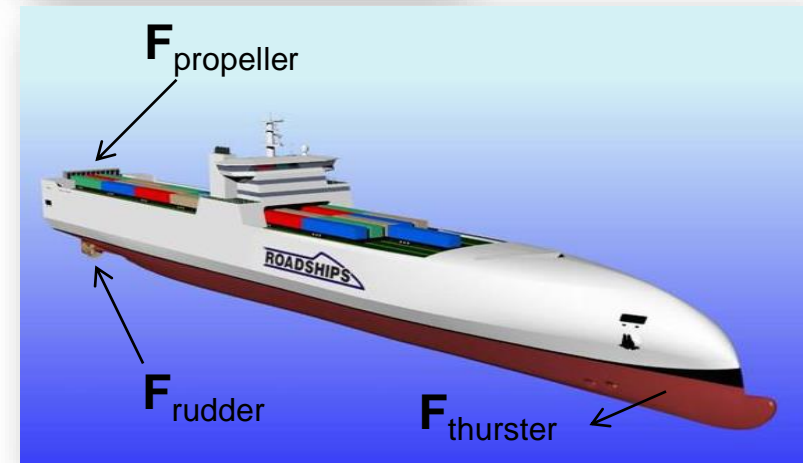

Motivation

- A ship should be able to operate according to her mission
- Ship dynamics are affected by the environment, the hull form and the appendages
- Appendages (propeller, rudder, pods, thrusters, etc.) imply forces and moments on the hull and they interact with the wave environment. By altering the properties of these systems during design we influence:
 - Seakeeping dynamics
 - Hull resistance in waves
 - Manoeuvrability
- These changes may lead to better or worse performance and increased or reduced safety

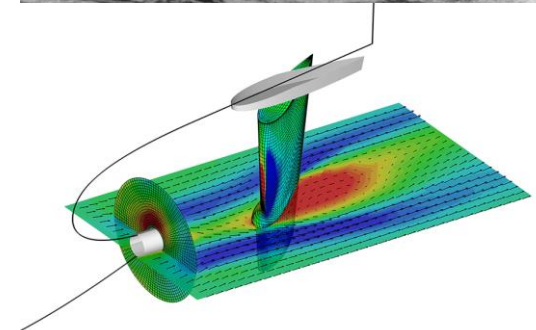

Design focus

- Once we select the main dimensions and the mission of a vessel we have define the bounds of her seaworthiness
- Items to consider
 - ✓ *Undesirable motions – sea sickness, capsizing*
 - ✓ *Resistance – hull performance*
 - ✓ *Stability - motion stabilisation systems*
 - ✓ *Propulsors and auxiliary appendages - efficiency*

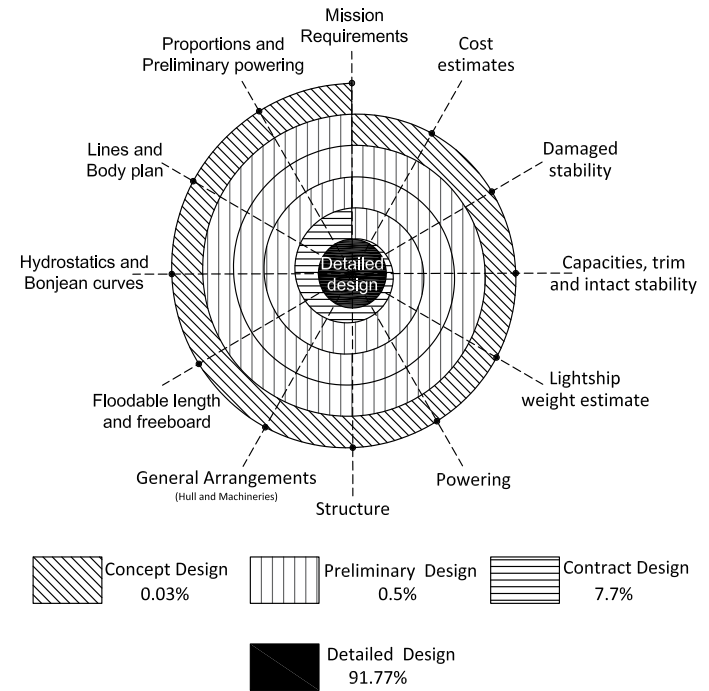

Ship resistance

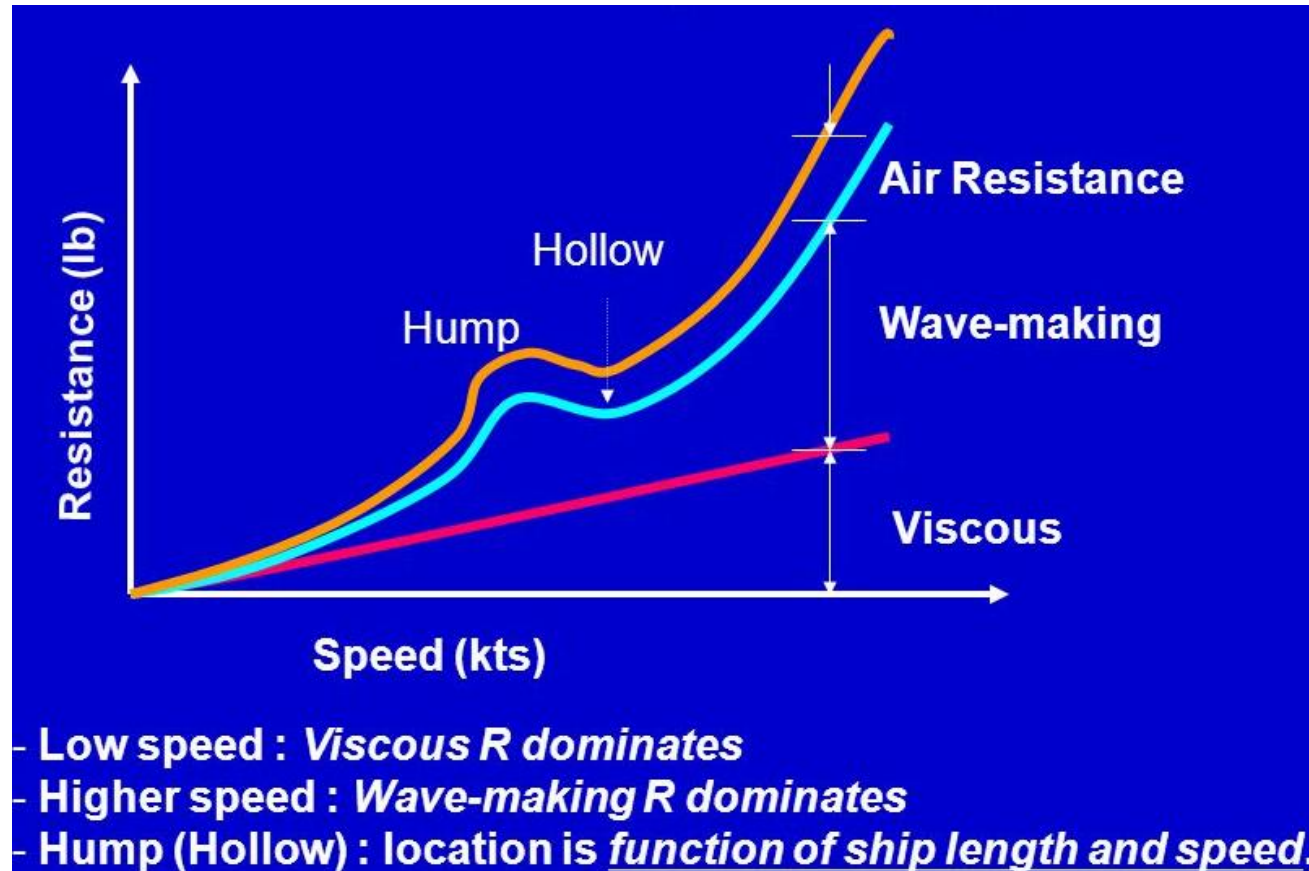

Ship Resistance & Propeller Thrust (Method 1)

The ideal world : Resistance magnitude = Thrust magnitude

- ✓ Resistance + Thrust magnitudes do not change
- ✓ If there is a change of ship's speed during the maneuvers it is caused by cross-coupling between ship speed and angular inflow velocity (e.g., see [vector derivatives](#) ; [term \$r'v\$](#) in [Matusiak \(2021\)](#) and [Lecture 2 course notes](#))

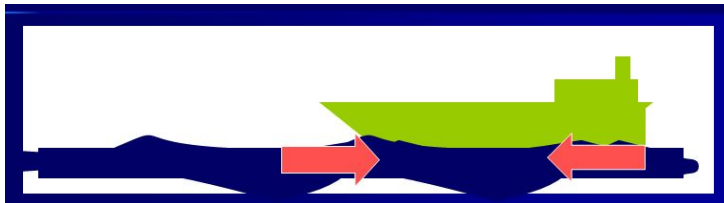

THRUST > RESIST

- Ship **accelerates**
- Resistance **increases** with speed
 - Until **Resistance = Thrust**
 - Ship at new, **faster** speed

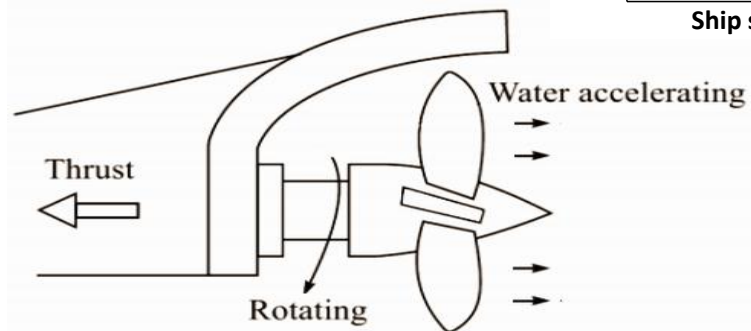
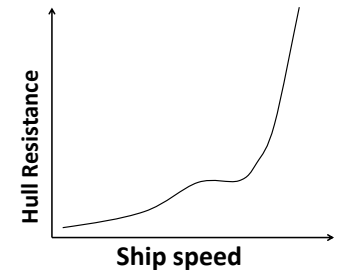

Elements of ship resistance (1)

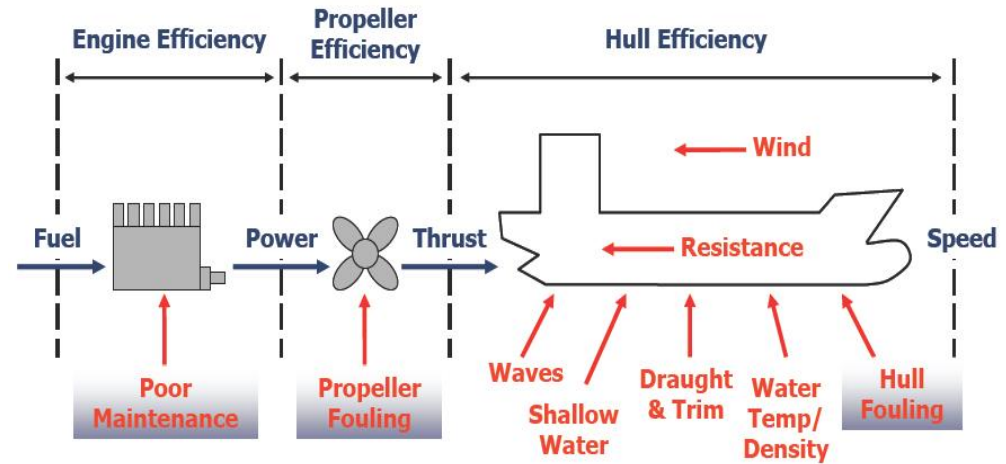
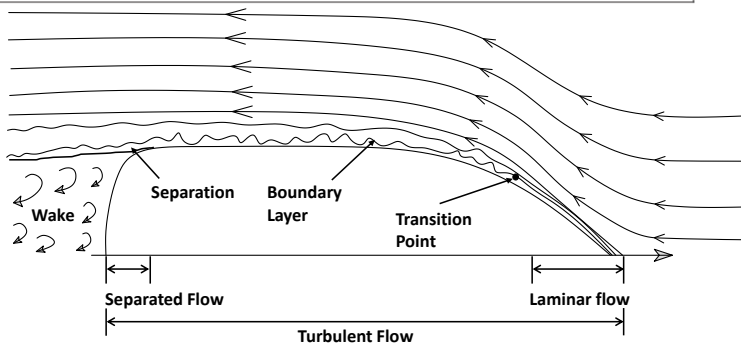
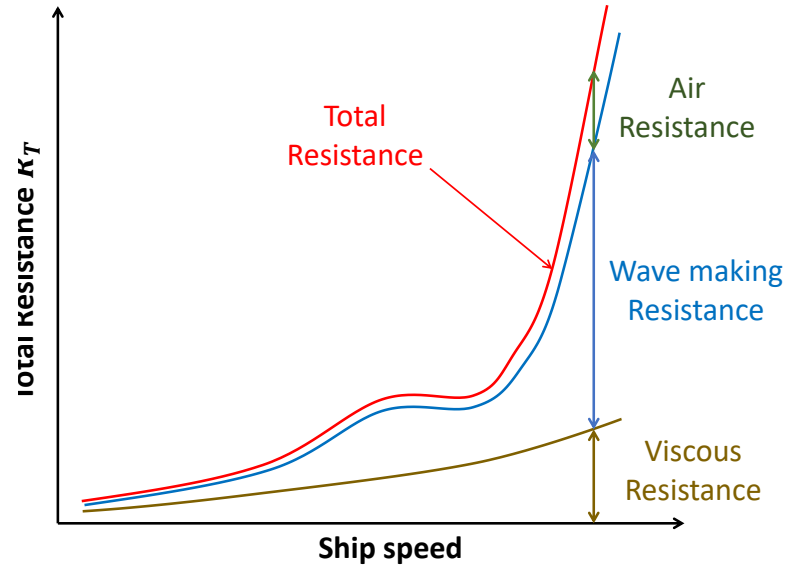
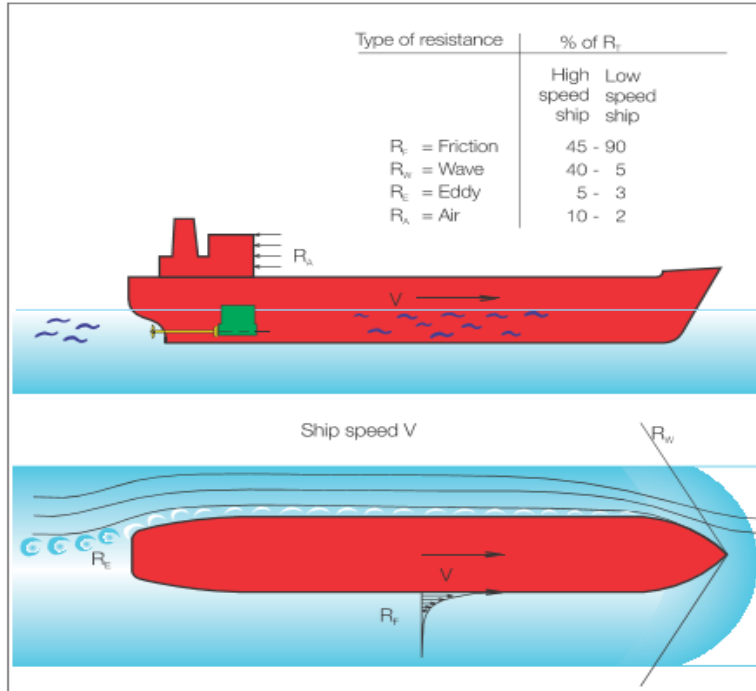
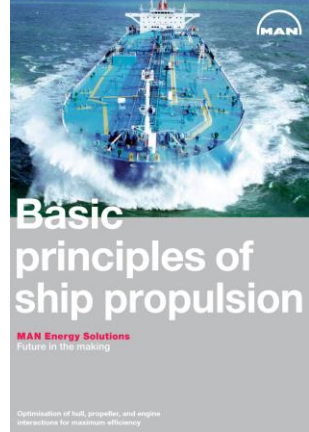

Elements of ship resistance (2)

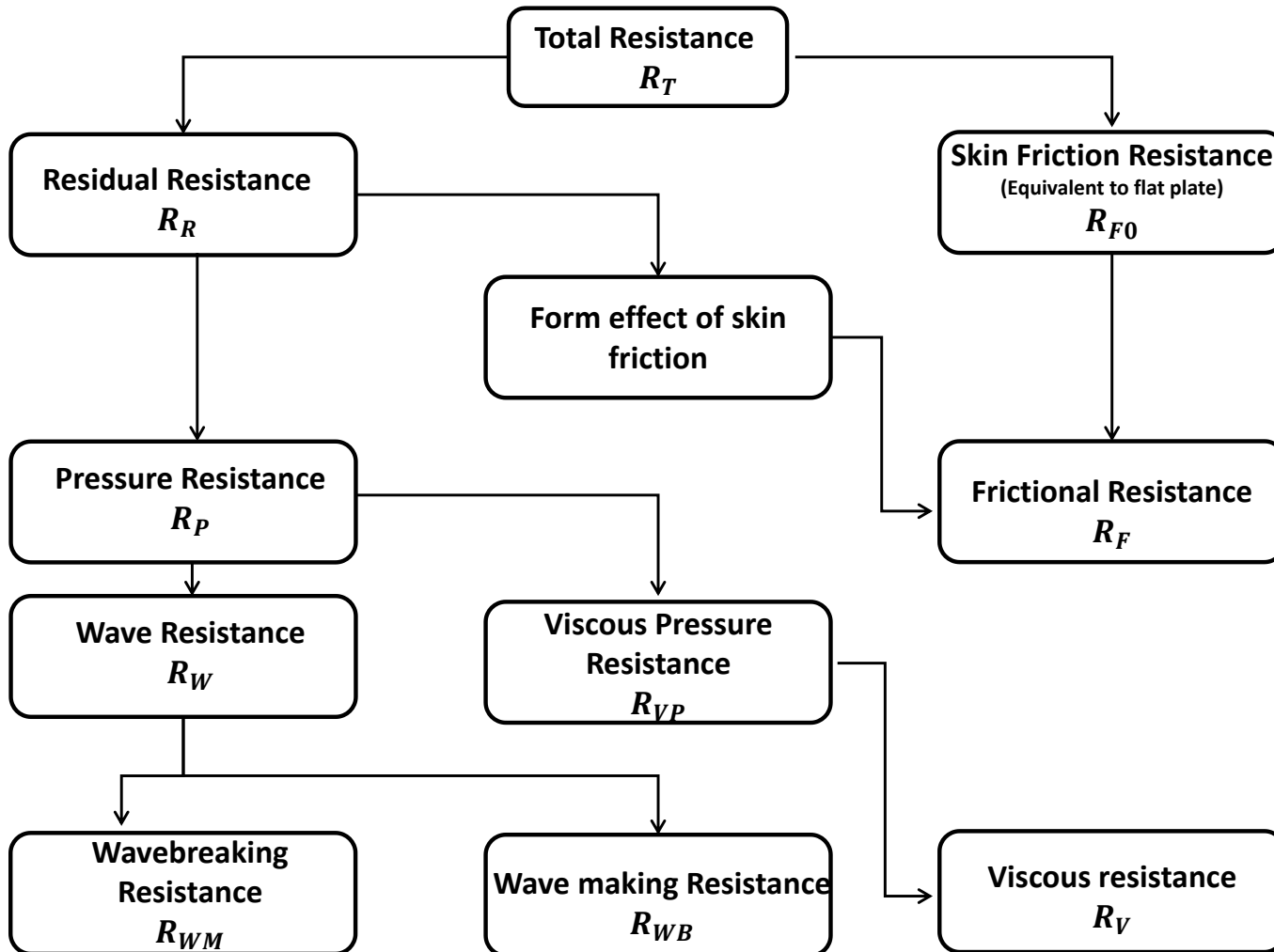

Residual resistance

□ Wave resistance

- ✓ The second major component of hull resistance.
- ✓ The generated wave pattern “Kelvin pattern” has two main features: Divergent waves and Transvers waves
- ✓ **Diverging waves** (stationery) on each side of the pressure point with their inclined crests intersecting the centerline at 19.5° .
- ✓ **Transverse waves** (progressive) with curved crests intersecting the centerline at right angles

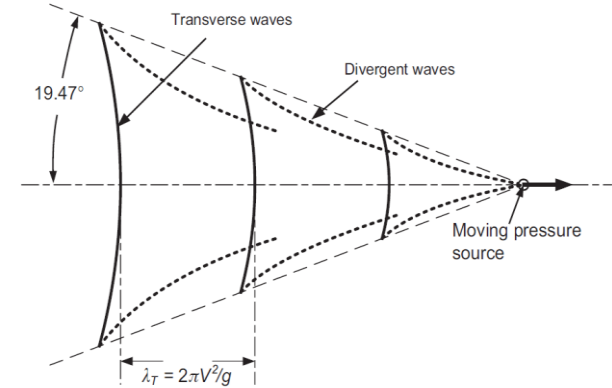

- ## □ Eddy making resistance formed in way of the stern and projecting parts such as bossing and bilge keels.



Other resistance components

- ❑ **Air resistance** acts on portions of the ship above the water line. It is affected by shape of the ship above the waterline, projected area, speed.
- ❑ **Wind resistance** is a function of the ship's sail area, wind velocity and direction.
- ❑ **Ocean currents** affects the power required to maintain a desired speed.
- ❑ **Added resistance:** lose of energy due to the increased wetted surface area, rolling, pitching, and heaving in waves.
- ❑ **Shallow waters resistance** increases viscous resistance due to Squat.

Effective, Thrust and Developed Power

- The ship effective power $P_E = R_T \cdot V_S$
- Thrust Power $P_T = T \cdot V_A$
 - Where V_A is the flow speed upstream the propeller, usually lower than ship speed due to ship's wake.
- Ship's wake $w = 1 - \frac{V_A}{V_S}$, $w \approx 0.25$ for single screw vessel $w \approx 0.05$ for Multi-screw vessel. May have adverse or beneficial effects.
- Developed power: $P_D = \frac{P_E}{\eta_D} = \frac{R_T \cdot V_S}{\eta_D}$; $\eta_D = \eta_o \eta_R \frac{(1-t)}{(1-w)}$ where the open water efficiency $\eta_o = 0.65$ and the relative rotative efficiency $\eta_R = 1$.

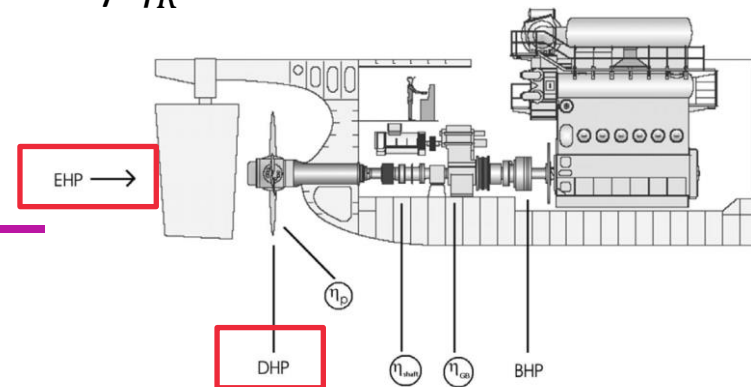

Ship Resistance & Propeller Thrust

(Method 2 – The modular model)

❑ Thrust deduction fraction principle

- ❑ The propeller increases the resistance of the ship by increasing the velocity along the hull (generally a small effect) and by decreasing the pressure around the stern. The increase of resistance due to the propeller action is expressed as the thrust deduction fraction $t = \frac{T - R_T}{T}$ where R_T is the total resistance as found by the resistance tests and T is the thrust required to maintain a certain speed.



- ❑ The relationship between resistance and thrust is $R_T = T(1 - t)$

- ❑ Resistance due to propeller dynamics becomes

$$X_{\text{resistance}} = -R_T / (1 - t) = -0.5 \rho u^2 S C_T / (1 - t)$$

R_T =total resistance, t =thrust deduction factor, ρ =density, u =x-direction velocity, S =wetted surface area, C_T =total resistance coefficient expressed as function of Froude no.

Fixed vs Controllable pitch propellers

**Fixed pitch propeller
(FP-Propeller)**

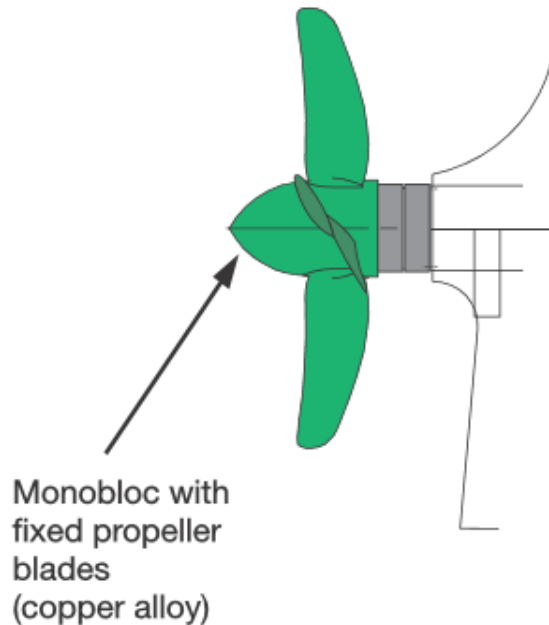

**Controllable pitch propeller
(CP-Propeller)**

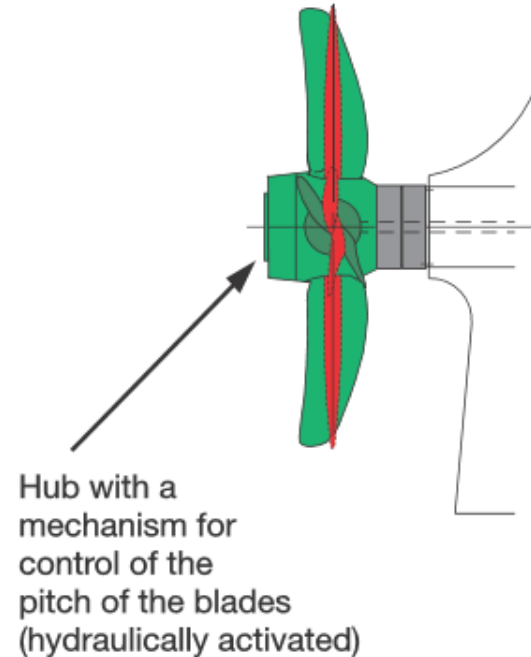

Thrust - Fixed pitch propeller

- ❑ The total thrust is evaluated from the open water characteristics (K_T - J curve) as

$$X_{prop} = Z\rho n^2 D^4 K_T$$

where Z is the no of propellers, n is the no. of propeller revolutions per second and D the propeller diameter.



- ❑ The initial value of propeller revolutions should be adjusted so that a desired ship velocity is obtained for the still water, constant forward speed with no drift angle condition i.e. the propeller revs should be derived from the condition $X_{prop} = -X_{resistance}$.
- ❑ The revolutions are kept constant or adjusted to keep the propeller advance coefficient $J = \frac{V_A}{nD} = \frac{V(1-w)}{nD}$ constant. **(NB : J expresses the propeller efficiency in dimensionless format)**
- ❑ Keeping the revs constant is recommended as it results in a smaller deviation from the initial value of the forward speed.

Thrust - Controllable pitch propeller

- If we assume that : *Constant delivered power = Constant propulsive efficiency*
 - Propeller pitch control is good and efficiency losses (aprox 10%) for the off-design operational conditions can be disregarded.
 - The above assumptions and resistance vs. power equations result in the following relation of thrust X_{prop} and ship's speed

$$X_{prop} = \frac{P_D \eta_0 \eta_R}{V(1 - w)}$$



*Typically the thrust forward and backward **is not equal** which means that for example in ice rules you have to be able turn the direction of engine revs. Otherwise you may end up with unreaalistically high thrust.*

Rudder & Steering (home review exercise)

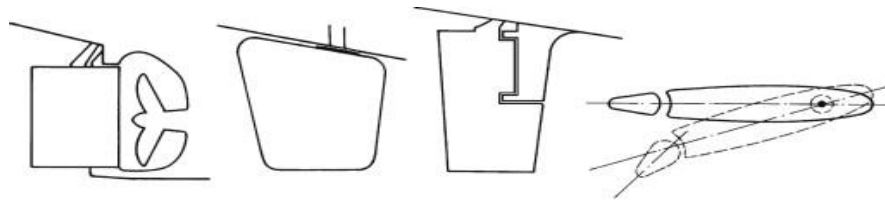

Simplex rudder

Spade rudder

Semi-balanced rudder

Flap rudder



RULES FOR CLASSIFICATION

Ships

Part 3 Hull

Chapter 14 Rudders and steering

- ❑ **Mean Span** - average of leading and trailing edge spans
- ❑ **Mean Chord** - average of the root and tip chords
- ❑ **Profile Area** - product of mean span and mean chord
- ❑ **Aspect Ratio** - ratio of mean span to the mean chord
- ❑ **Taper Ratio** - ratio of the tip chord to the root chord
- ❑ **Sweepback Angle** - angle between 1/4 chord line and vertical
- ❑ **Mean Thickness** - average of the max thickness of the foil at the root and tip

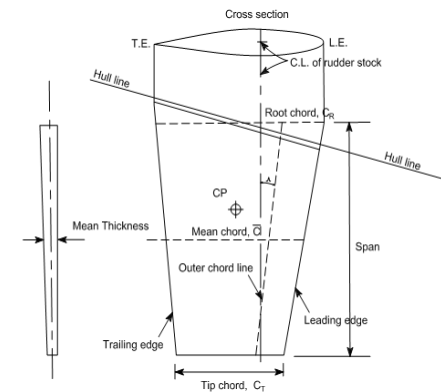

Tutorial :

<https://www.bing.com/videos/search?q=ship+Rudder+Types+&&view=detail&mid=0BD9ABF00E23E432F7D90BD9ABF00E23E432F7D9&&FORM=VDRVRV>

Rudders – key design characteristics

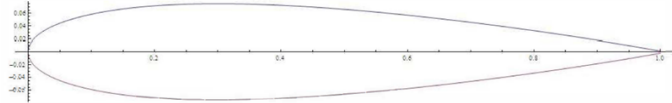

NACA 0015 to 0021 (relatively thick)

$$A_R = \frac{T \times L_{BP}}{100} \left[1 + 25 \left(\frac{B}{L_{BP}} \right)^2 \right]$$

Rudder Area coefficients

Vessel Type	Typical Form Coefficients and Ratios			Speed V, knots	Froude No. V/\sqrt{gL}	Number of Propellers/Rudders	Rudder Area Ratios*	Dynamic Course Stability*
	C_D	L/B	B/T					
Harbor tug	0.50	3.3	2.1	10	0.25	1/1	0.025	S
Tuna seiner	0.50	5.5	2.4	16	0.31	1/1	0.025	S
Car ferry	0.55	5.1	4.5	20	0.34	2/2	0.020	S*
Container high speed	0.55	8.2	3.0	28.5	0.53	2/2	0.015	S*
Container high speed	0.55	8.3	3.0	28.5	0.53	2/1	0.025	S*
Cargo liners	0.58	6.9	2.4	21	0.29	1/1	0.015	S
RO/RO	0.59	6.9	3.0	22	0.26	1/1	0.015	S
Barge carrier	0.64	7.5	2.9	19	0.20	1/1	0.015	S
Container Med. Speed	0.70	7.1	2.8	22	0.25	1/1	0.015	S
Offshore supply	0.71	4.7	2.75	13	0.28	2/2	0.016	S*
General cargo low speed	0.73	6.7	2.4	15	0.20	1/1	0.015	S
Lumber low speed	0.77	6.7	2.6	15	0.20	1/1	0.025	S
LNG (125 000 m ³)	0.78	6.8	3.7	20	0.20	1/1	0.015	U
OBO (Panamax)	0.82	7.5	2.4	16	0.17	1/1	0.018	U
OBO (150 000 dwt)	0.85	6.4	2.4	15	0.15	1/1	0.017	U
OBO (300 000 dwt)	0.84	6.0	2.5	15	0.14	1/1	0.015	U
Tanker (Panamax)	0.83	7.1	2.4	15	0.16	1/1	0.015	U
Tanker 100 000 to 350 000 dwt	0.84	6.2	2.4	16	0.15	1/1	0.015	U
Tanker 350 000 dwt	0.86	5.7	2.8	16	0.13	1/1	0.015	U
U.S. river towboat	0.65	3.5	4.5	10	0.25	2/2	...	U**

* Not for design guidance.
 * U = unstable course stability; S = stable course stability.
 * Although the vessel is directionally stable, maneuvering is difficult at low speeds when the propeller wash is not effective over the rudder.
 * Maneuverability is good owing to installation of Kort nozzles, flanking rudders, and other capabilities.
 * Twin screw because of restricted draft.

Vessel Type	Percent of $L \times T$
Single-screw vessels	$L \times T$
Twin-screw vessels	1.6 to 1.9
Twin-screw vessels with two rudders (total area)	1.5 to 2.1
Tanlrers	2.1
large passenger vessels	1.8 to 1.9
Fast passenger vessels for canals	1.2 to 1.7
Coastal vessels	1.8 to 2.0
Vessels with increased maneuverability	2.3 to 3.3
Fishing trawlers and vessels with limited saifing area	2.0 to 4.0
Seagoing tags	2.5 to 5.5
Sailing vessels	3.0 to 6.0
Pilot vessels and faxries	2.0 to 3.0
Motorboats	2.5 to 4.0
Keeled launches and yachts	4.0 to 5.0
Centerboard boats	5.0 to 12.0
	30 or more

Rudder dynamics

- Rudder set at angle δ develops a +ve force in Y-dir defined as $Y_{\delta}\delta$ (in *simplified format*)
- As this force acts on the ship's stern aprox. half way aster from the origin [0] a - ve turning moment $N_{\delta}\delta$ develops
- This moment makes the ship to turn and sets it at a certain drift angle β
- The turning motion initiated by the rudder is greatly amplified by the turning moment $N_{\nu\nu}$ developed by a hull set in inclined flow
- Thge rudder action can be modelled by :
 - ✓ **Method 1 :** Stability derivatives (direct representation of the hull forces asdependent to the rudder angle)
 - ✓ **Method 2 :** Modular model (kinematic of inflow into the rudder & modelling of effect of propeller flow on rudder action)

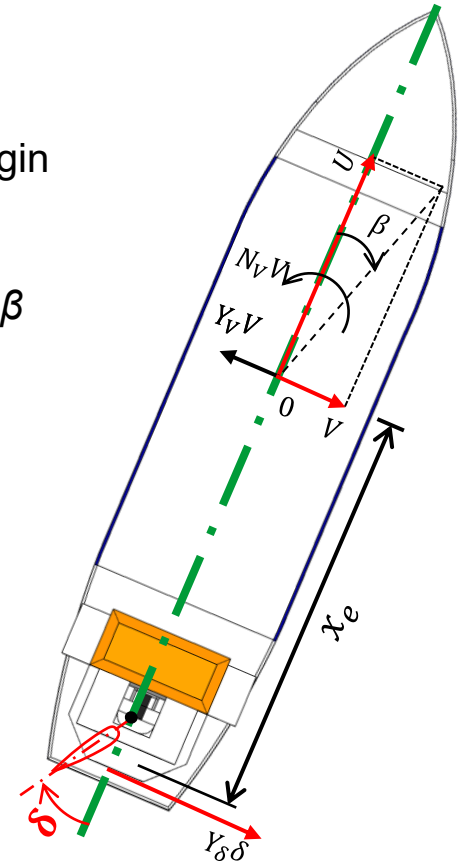

Rudder kinematics

- ❑ The rudder angle and the angle at which the flow enters the rudder, **the angle of attack**, are not the same
- ❑ This is why the force $Y_\delta \times \delta$ is just a first approx.
- ❑ Both the inflow velocity and the angle of attack are affected by the **yaw** and **sway** motion of the ship
- ❑ If the rudder is located in the propeller slipstream this will also affect the inflow
- ❑ Inflow into the rudder may be also changed significantly due to the flow velocity in the surface wave

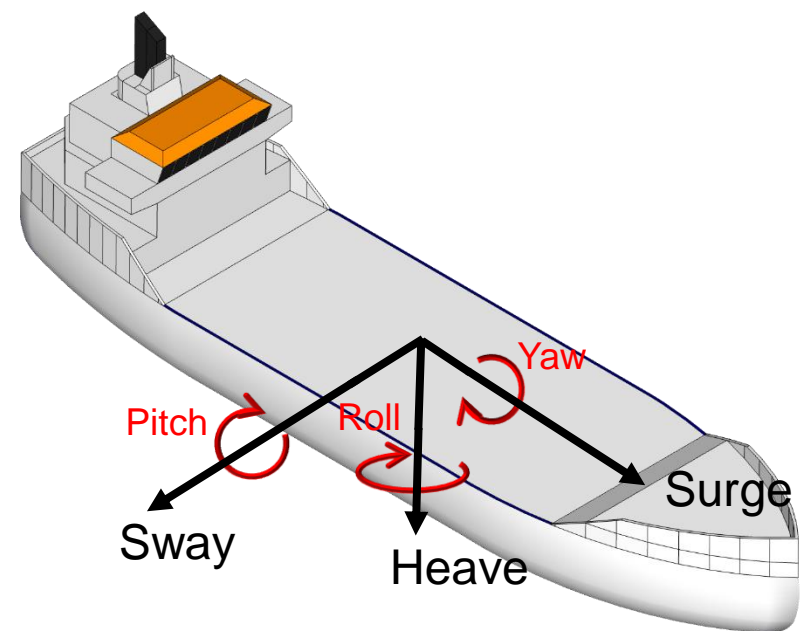

Translation of rotation	Axis	Description	Positive sense
Translation	Along x	Surge	FWD
	Along y	Sway	SB
	Along z	Heave	D
Rotation	About x	Roll	SB – D
	About y	Pitch	Bow up
	About z	Yaw	Bow to SB

$$\begin{Bmatrix} V_{x,R} \\ V_{y,R} \\ V_{z,R} \end{Bmatrix} = \begin{Bmatrix} V_x - V_{x,wave} \\ -v + V_{y,wave} \\ -w + V_{z,wave} \end{Bmatrix} - \begin{Bmatrix} -i & j & k \\ p & q & r \\ x_R & y_R & z_R \end{Bmatrix} \rightarrow \begin{aligned} V_{x,R} &= V_x - V_{x,wave} - qz_R + ry_R \\ V_{y,R} &= -v + V_{y,wave} - rx_R + pz_R \\ V_{z,R} &= -w + V_{z,wave} - py_R + qx_R \end{aligned}$$

Rudder kinematics

$$\begin{Bmatrix} V_{x,R} \\ V_{y,R} \\ V_{z,R} \end{Bmatrix} = \begin{Bmatrix} V_x - V_{x,wave} \\ -v + V_{y,wave} \\ -w + V_{z,wave} \end{Bmatrix} - \begin{Bmatrix} -i & j & k \\ p & q & r \\ x_R & y_R & z_R \end{Bmatrix} \rightarrow \begin{aligned} V_{x,R} &= V_x - V_{x,wave} - qz_R + ry_R \\ V_{y,R} &= -v + V_{y,wave} - rx_R + pz_R \\ V_{z,R} &= -w + V_{z,wave} - py_R + qx_R \end{aligned}$$

- V_x is the longitudinal (x -component) of flow velocity along the propeller slipstream;
- p, q and r are the angular velocity components expressed in the moving co-ordinate system x, y, z .
- The subscript “wave” is referred to the flow velocities due to the contribution of wave action;
- (x_R, y_R, z_R) represent the positions of the rudder in the body-fixed coordinate system
- V_R is the rudder flow velocity vector with **angle of attack**

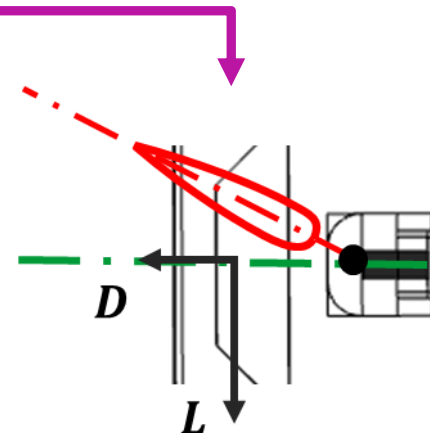
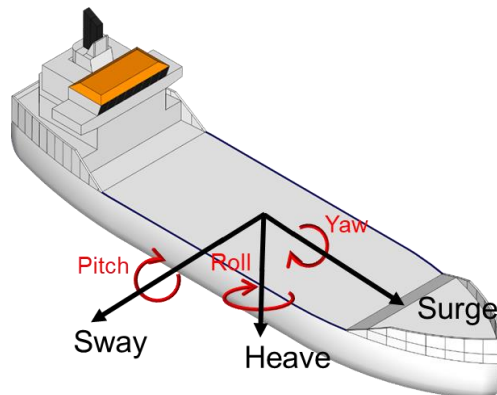

Effective angle of water inflow

- To evaluate the rudder forces the flow velocities at the rudder location have to be evaluated first
- The effect of ship motion and wave motion is to change the angle of attack of the rudder by the amount

$$\gamma = \arctan (V_{y,R}/V_{x,R})$$

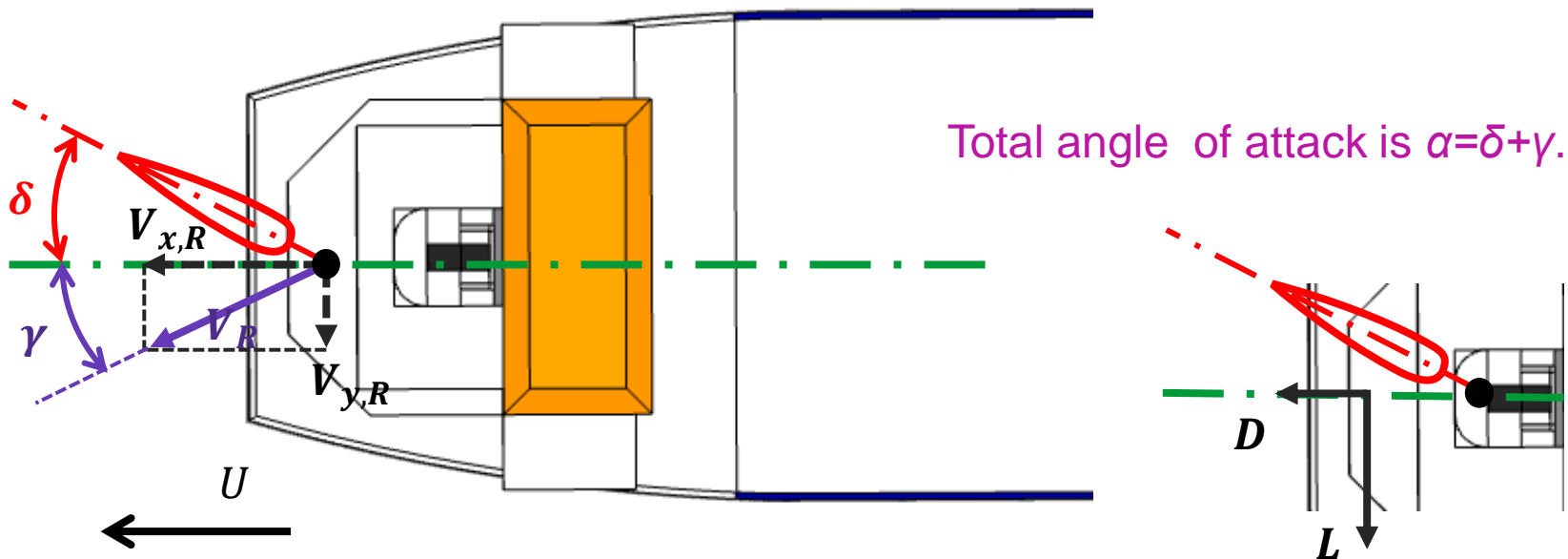

Rudder forces

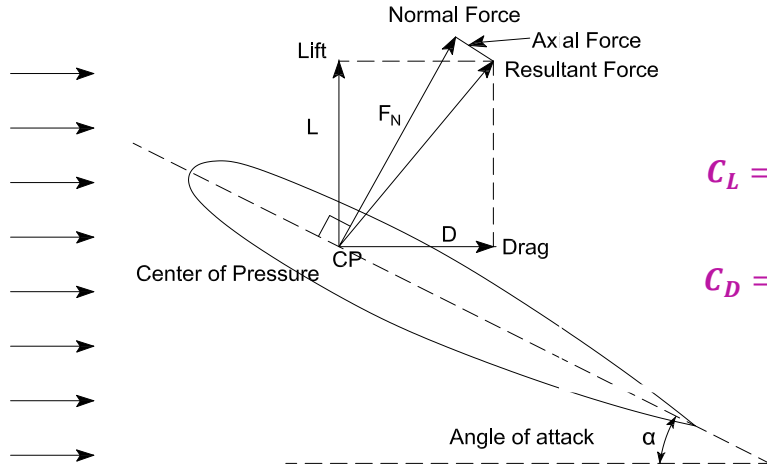

$$C_L = \frac{L}{\frac{1}{2} \rho U^2 c}$$

$$C_D = \frac{D}{\frac{1}{2} \rho U^2 c}$$

Forces on an airfoil

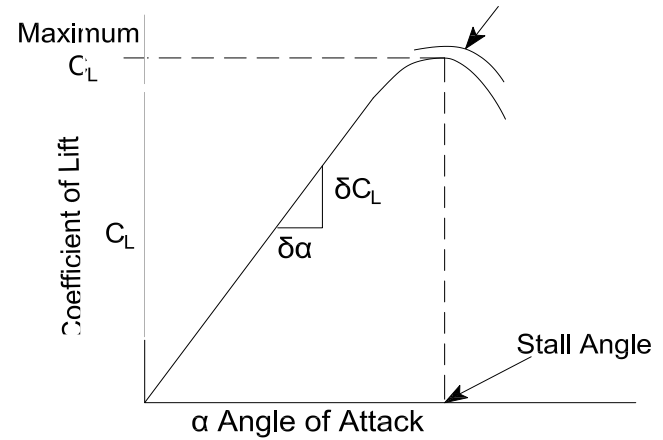

A typical ship's rudder is limited to angles in the range of $\pm 35^\circ$. This is because at greater angles than these the rudder is likely to stall.

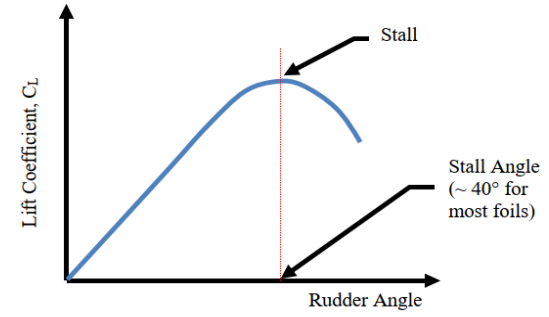
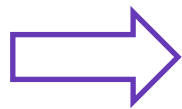

Rudder forces – potential flow (1)

- Rudder forces are evaluated according to Söding (1982) and Brix (1993) [Ref : Matiusek (2021) and Lecture 2 course notes]

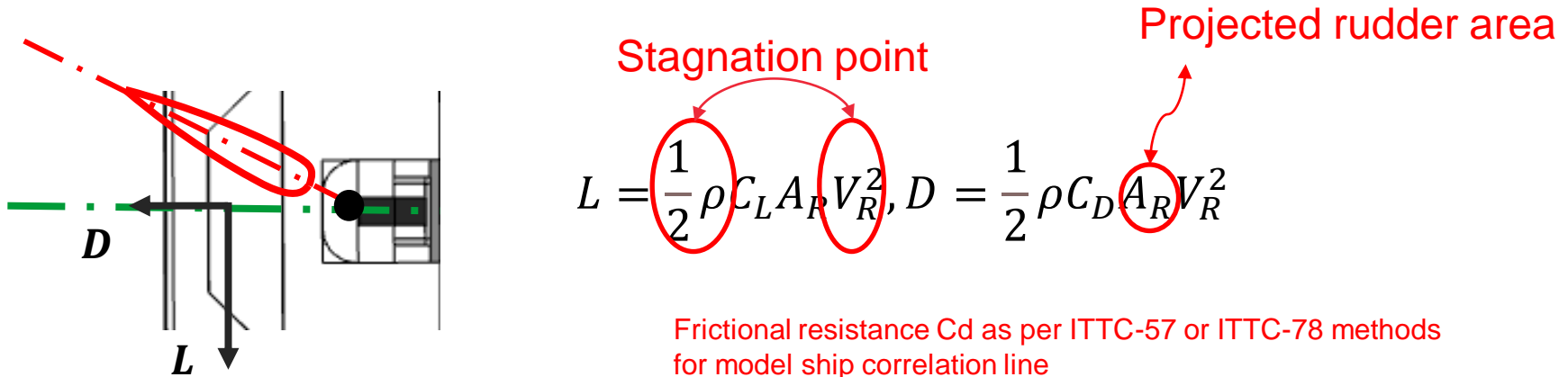

Stagnation point

$$L = \frac{1}{2} \rho C_L A_P V_R^2, D = \frac{1}{2} \rho C_D A_R V_R^2$$

Projected rudder area

Frictional resistance C_d as per ITTC-57 or ITTC-78 methods for model ship correlation line

Drag Coefficient

$$C_D = 1.1 \frac{C_L^2}{\pi \Lambda} + C_{D0}$$

Lift Coefficient

$$C_L = \frac{2\pi\Lambda(\Lambda + 1)}{(\Lambda + 2)^2} \sin(\delta + \gamma)$$

$\Lambda = b^2/A_R$ is aspect ratio and b denotes rudder length. Note that rudder area is not a wetted area. It is defined as a projected area of the side view of the rudder, C_{D0} is viscous drag coefficient, equals $C_{D0} = 2.5 C_F$

Rudder forces – viscous flow (2)

□ ITTC 1957 - frictional resistance coefficient

$$C_{D0} = 2.5 C_F = 2.5 \frac{0.075}{(\log Re - 2)^2}$$

$$Re = \frac{V_R c}{\nu}$$

- Re = Reynold's number
- c = mean value of the rudder cord
- ν = kinematic viscosity

Rudder flow patterns at increasing rudder angle

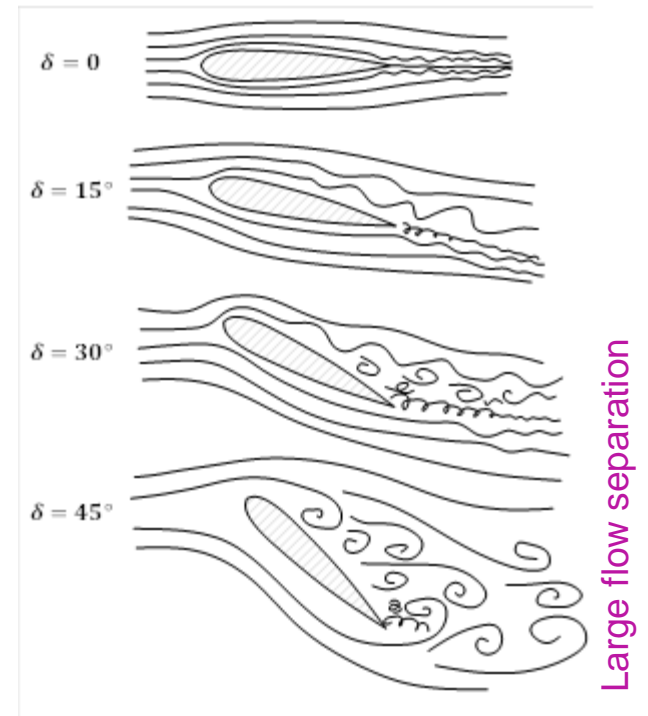

Effect of propeller action on rudder flow

- ❑ Assume the rudder operates in the propeller slipstream
- ❑ As a result the forces developed by the rudder are substantially higher than the ones generated by the rudder placed outside the slipstream
- ❑ According to potential flow theory and considering the momentum conservation (ideal propulsion model), the mean axial flow velocity far downstream of the propeller is

$$V_{\infty} = V_A + U_{A0} = V_A \sqrt{1 + C_T}$$

$$C_T = \frac{\text{Thrust}}{0.5 \rho V_A^2 \pi D^2 / 4} = \frac{8 K_T}{\pi J^2}$$

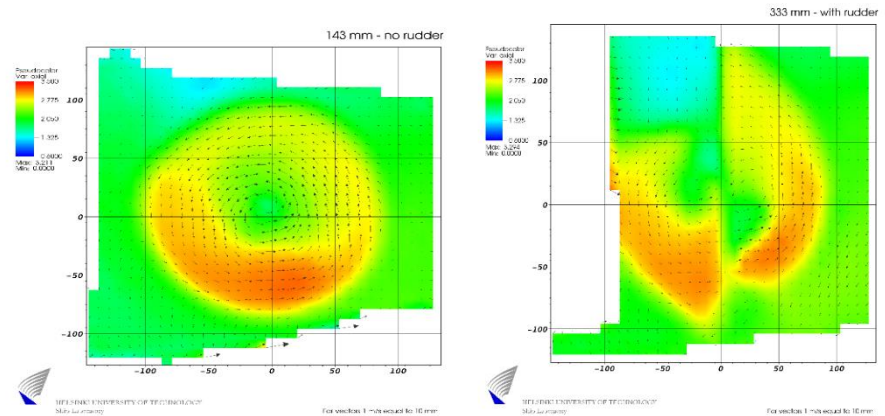
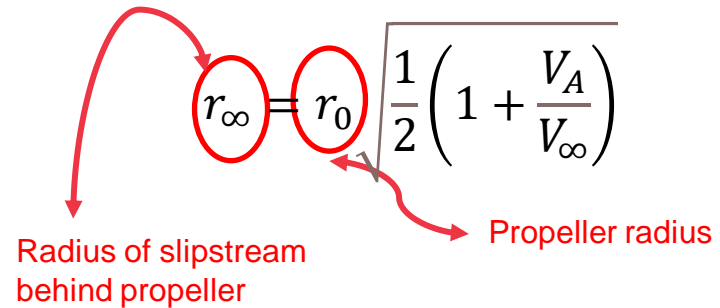

C_T is the thrust loading coefficient V_{∞} is the mean flow velocity far downstream the propeller, r_{∞} is the radius of the slipstream far behind the propeller, r is the slipstream radius at the rudder, r_0 is the propeller radius.

Slow ship manouvability

- ❑ A ship should maintain sufficient and independent directional control in ports and channels

- ❑ In such conditions rudders are limited in terms of their effectiveness due to lack of flow across their surface.
 - ✓ *The rudder is often positioned directly upon the control surface.*
 - ✓ *Two propellers can be set to work in unison (twin propulsion concept).*
 - ✓ *Lateral thrust at the bow and the stern is possible when **bow thrusters** are enclosed in transverse tubes/tunnels*
 - ✓ *Rotational thrusters (also known as **azimuth propulsion systems**) that rotate up to 360^0 (see Figure 2-14) can be used to improve efficiency in oblique flow conditions.*

Oblique flow and in-plane force

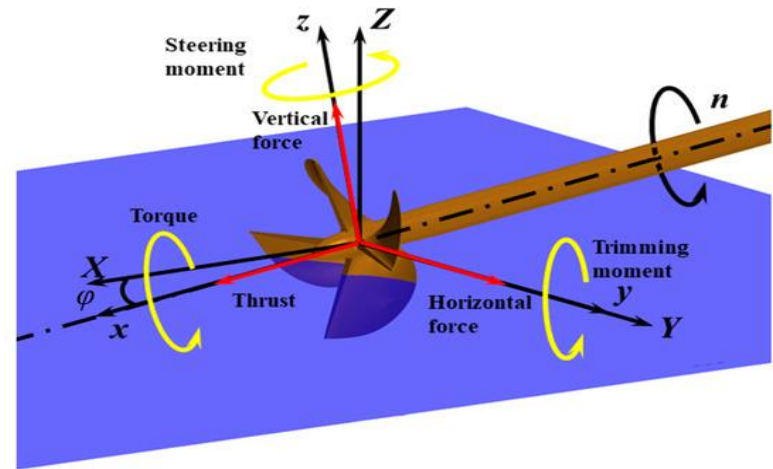
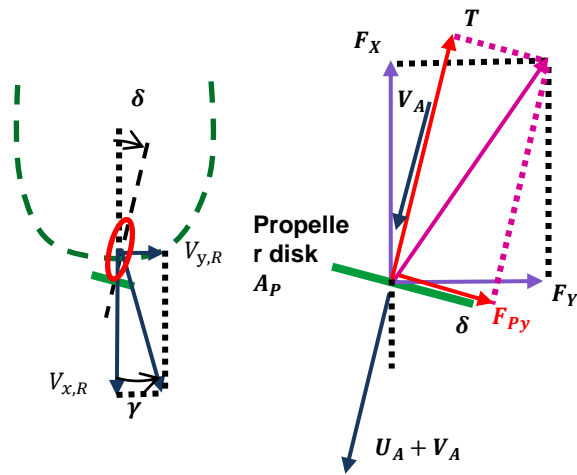

In plane force component

Propeller disc area

$$F_{py} = \rho A_p (V_A + U_A) V_{py}$$

$$V_{py} = V_{x,R} \sin \delta + V_{y,R} \cos \delta$$

In plane flow velocity

$$V_A = V_{x,R} \cos \delta - V_{y,R} \sin \delta$$

Propeller advance velocity

$$U_A = V_A (-1 + \sqrt{1 + C_T}) / 2$$

propeller induced velocity in the propeller plane

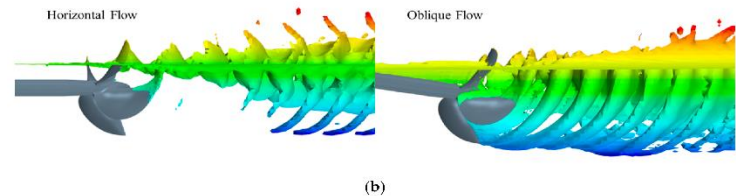
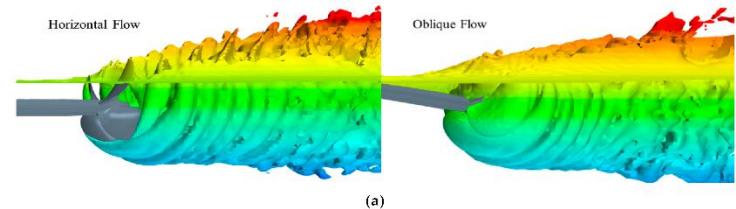

Azimuth thrusters

- Azimuth thruster units have become very popular in a variety of ship types within the last two decades, a.k.a. podded propellers
- Benefits
 - good maneuvering qualities
 - low vibration and noise
 - overall propulsion characteristics are good thanks to an absence of propeller shafts and supporting brackets.
- The biggest difference is that they operate frequently in oblique inflow



*For the case of an azimuth thruster knowledge of the forces developed by propeller in **oblique inflow is very important** in order to evaluate the ship's maneuvering. In particular, stopping a vessel may be conducted quite differently and faster than in a case of traditional propulsion arrangement*

Bow thrusters

- Bow thrusters are needed in manoeuvring in harbour operations
- Thruster works well with very low speeds in surge motion
- Depending on the required manoeuvrability there might be several (1-4) thrusters in way of the bow (and at the aft end)

<https://www.youtube.com/watch?v=PzjFEe47bzA>

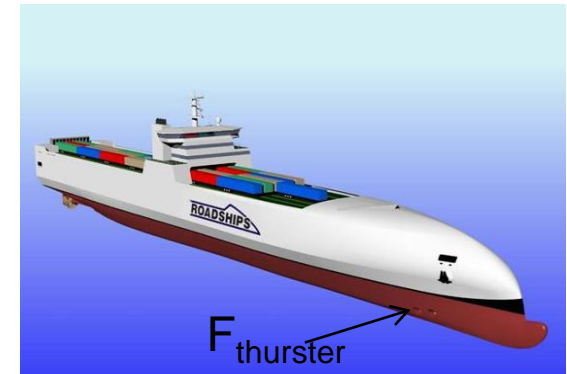

Bow thrusters

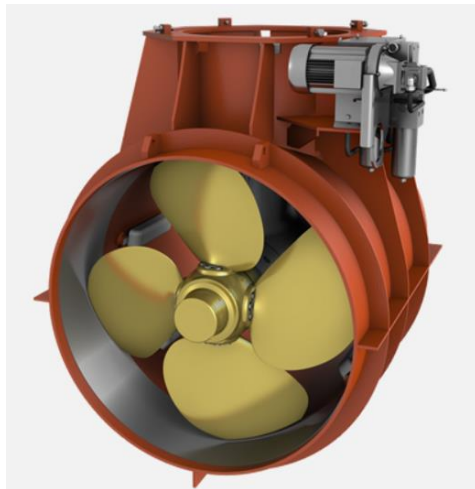
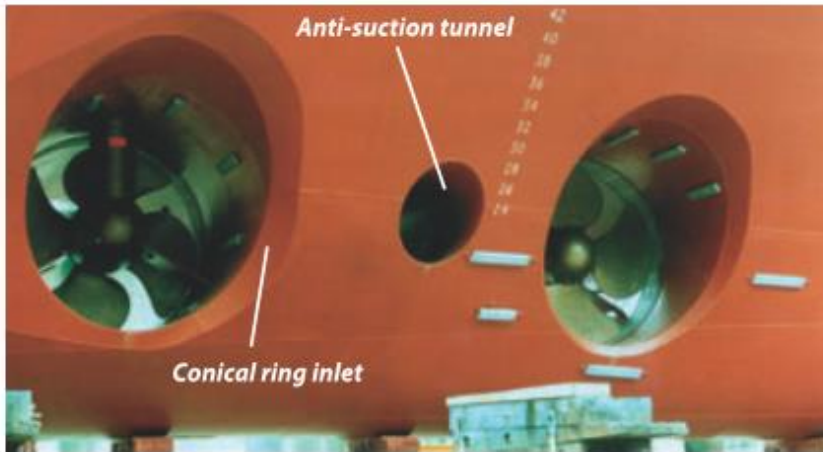

Illustrations courtesy of Wärtsilä Corporation

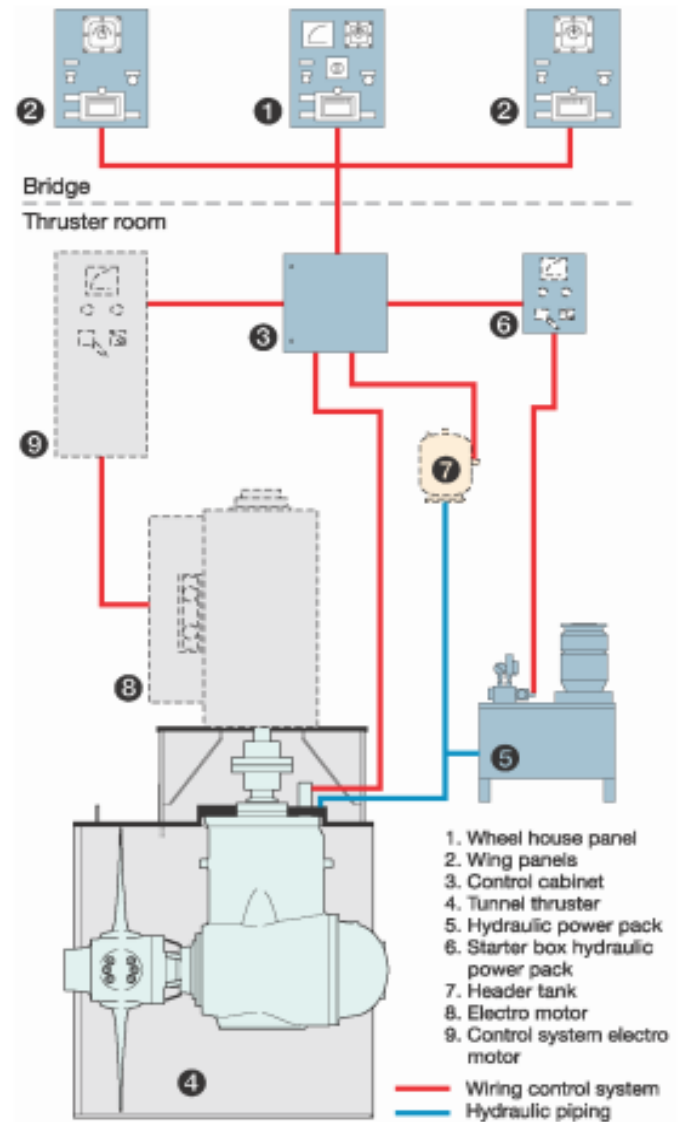

Hull form dynamics

- ❑ Hull form has significant impact on ship dynamics
- ❑ Too low freeboard may cause shipping of green water
- ❑ Too low draft can cause bow or aft slamming and/or propeller emergence
- ❑ The positioning of equipment and superstructure design should take into account the heavy loading due to rough seas
- ❑ The shape of hull form should be such that impact loads are minimised



Hull form dynamics - Motion Reduction

- ❑ Motion reduction is possible provided that we know the motions of the ship so that we create a mounted counter system that eliminates these movements
- ❑ Most often the motion reduction is most effectively done by dampers
- ❑ Dampers control forces and moments. However, they should be designed in a way that does not lead to significant hull space augmentations/corrections
- ❑ Roll is the motion that can be most effectively reduced using small forces and moments

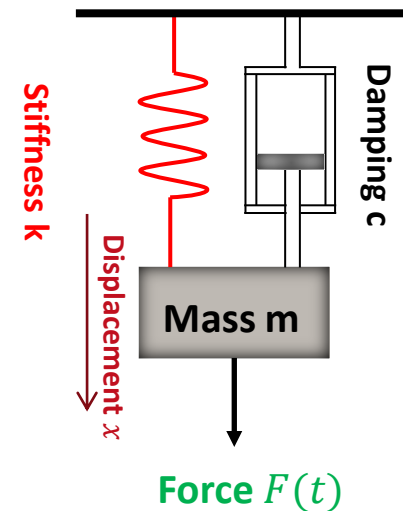
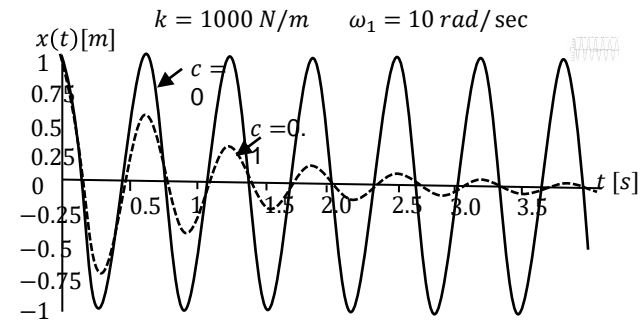

Hull form dynamics - Motion Reduction

- ❑ The key idea of motion reduction is to reduce the levels of kinetic energy lost in the system. In terms of dynamics this means that we should attempt to re-design the ship along the lines of 'conservative system' dynamics.
- ❑ Loss of kinetic energy is implied by wave making friction, production of eddies and additional force
- ❑ Motion reduction systems may also produce unwanted side effects, e.g. added resistance

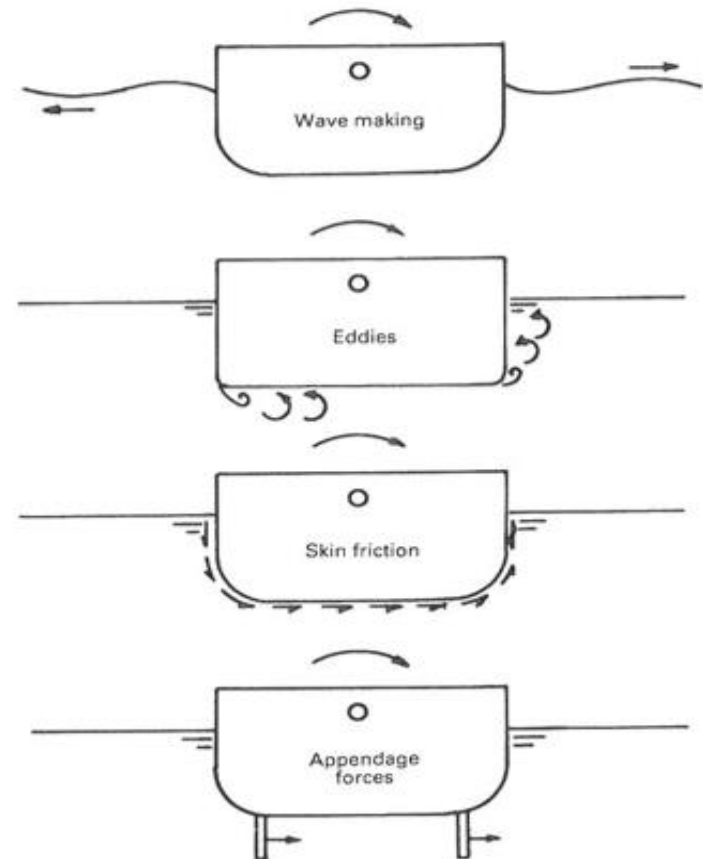
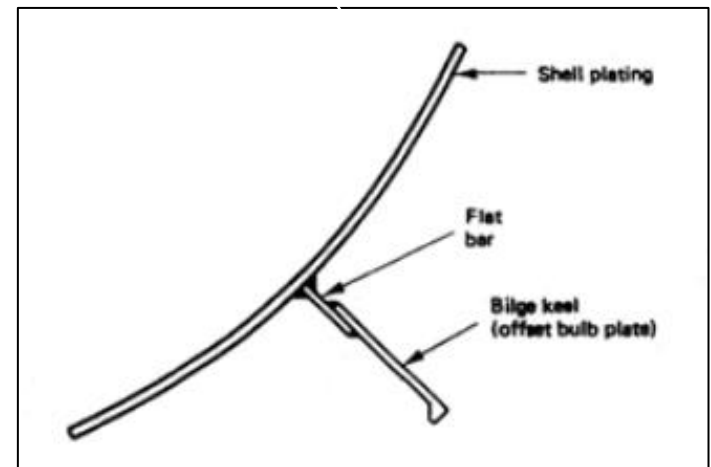

Fig. 12.1 — Sources of roll damping.

Bilge Keels

- ❑ Bilge keels are passive structures welded to the bilge region
- ❑ Bilge keels work by creating drag forces which oppose the roll motions
- ❑ They are considered one of the most cost effective ways to reduce roll motions because they:
 - ✓ Work well at all speeds
 - ✓ Have no moving parts
 - ✓ Require no special maintenance
 - ✓ They increase the resistance of the ship unless flow is not taken into account in the design (CFD, model tests)



Passive Tanks

- ❑ The liquid in partially filled tanks will slosh back and forth in ship as it rolls
- ❑ The shifting weight will exert a roll moment that is damping the rolling motion when suitably designed
- ❑ This tank works typically very well in slow speeds
- ❑ The system has no moving parts so the maintenance costs are low. However, extra hull space is required.
- ❑ The tank can be adjusted to only one frequency corresponding to the roll natural period at which large motion amplitudes occur

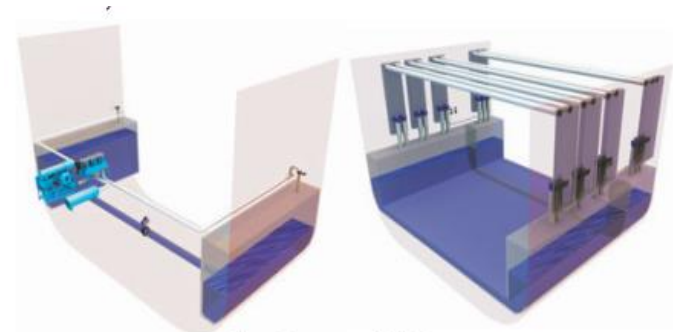
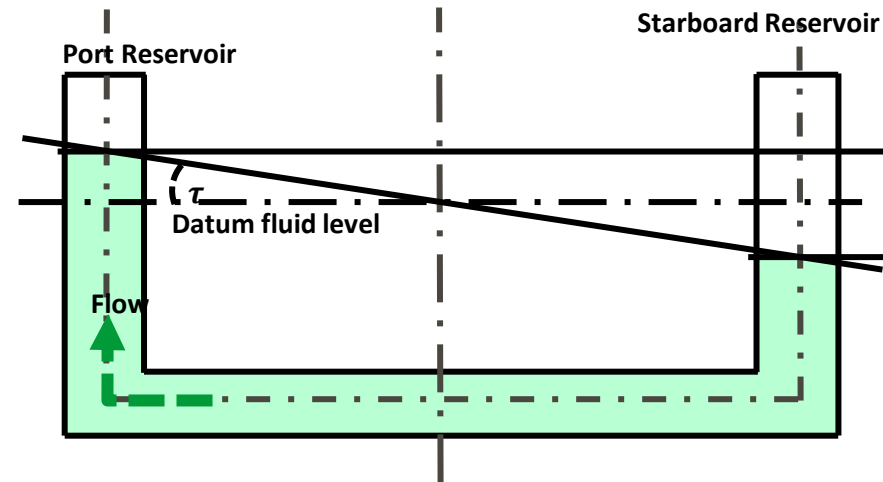

Illustrations courtesy of Rolls-Royce

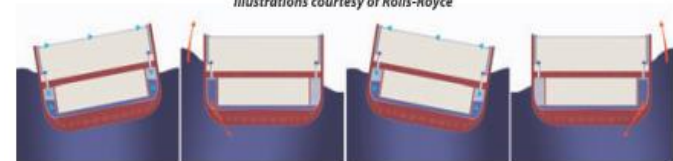

Active Tanks

- ❑ Similar to the principle of passive tank system
- ❑ The movement of water is controlled by
 - ✓ Pumps
 - ✓ Air pressure above the water surface.
- ❑ The tanks either side of the ship may be connected by a lower limb or two separate tanks can be used
- ❑ The air duct contains valves operated by a roll sensing device

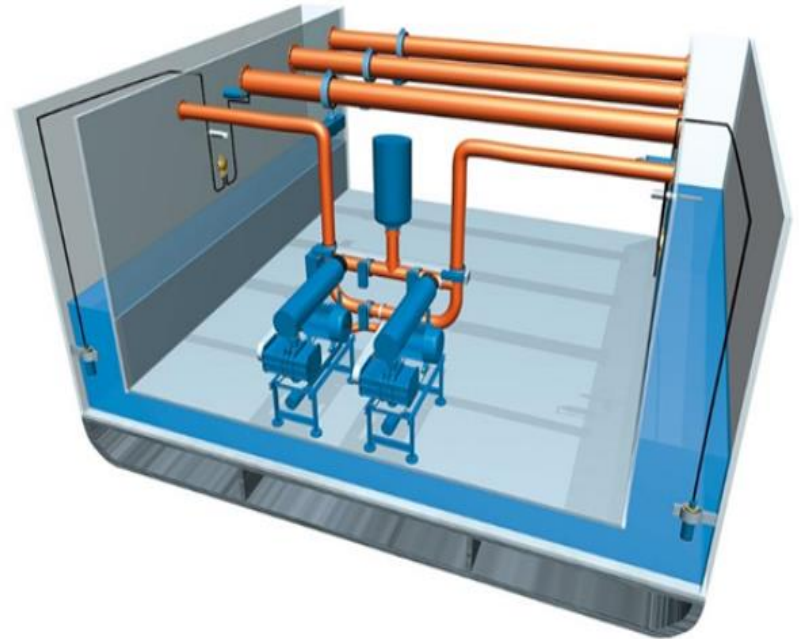

Stabilizer fins

- ❑ Active roll stabilizer fins are typically located near the bilge and amidships
- ❑ The angle of incidence is adjusted based on ship rolling motions
- ❑ The fins create counter rolling motion to that caused by the waves
- ❑ They cannot solve problems of very rough seas and are quite expensive to install and maintain. They also require extra space
- ❑ Retractable fins are often used in commercial ships. They require more hull space
https://www.youtube.com/watch?v=bjn_gRuBeV4
- ❑ Their interference with bilge keels should always be checked

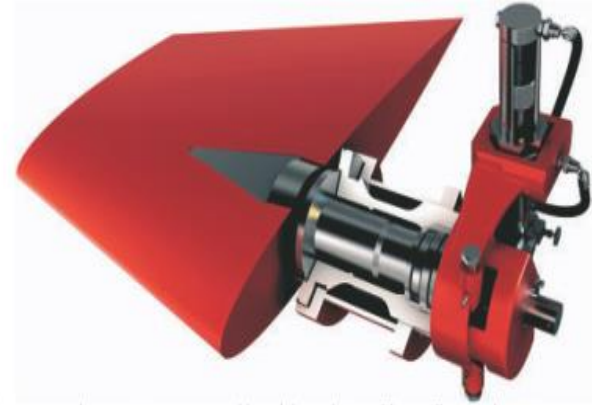
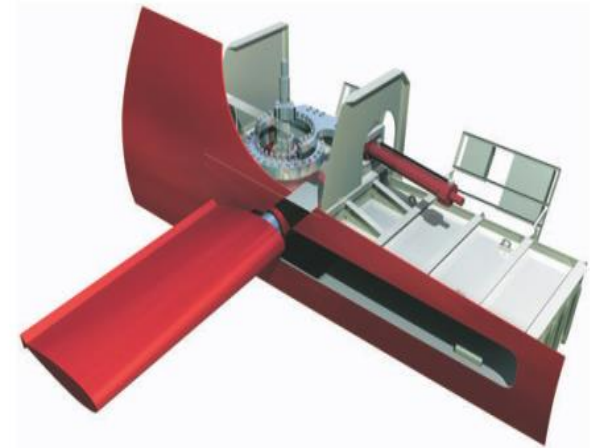

Control Systems

- Mathematical description of ship motion is important to facilitate and verify the design of the motion control systems.
- In 6-DOF mathematical models the energy from waves is distributed between the different motions which interact with each other.
- The roll motion, which is the most critical, can be simplified by one DOF equation

$$(I_{xx} + J_{xx})\ddot{\phi} + B_{xx}(\phi; \dot{\phi}) + \Delta GZ(\phi) = K_{ext}$$

6-DOF mathematical model

$$m(\dot{u} - v\dot{\psi}) = (m_y(\omega_e) - X_{v\dot{\psi}})u\dot{\psi} - m_x(\omega_e)\dot{u} - m_z(\omega_e)\dot{\theta} + \\ -m_z(\omega_e)w\dot{\theta} + X_{FK} + X_{RF} + X_{SF} + T(1 - t_p) - R$$

$$m(\dot{v} - u\dot{\psi}) = m_x(\omega_e)u\dot{\psi} - m_y(\omega_e)\dot{v} - Y_v v - Y_{\dot{\psi}}\dot{\psi} + \\ + Y_{\dot{\psi}}\dot{\psi} + Y_{v|v|}v|v| + Y_{v|\dot{\psi}|}v|\dot{\psi}| + Y_{\psi|\dot{\psi}|}\psi|\dot{\psi}| + \\ + Y_{FK}(\omega_e) + Y_{RF} + Y_{SF} + Y_{DF}(\omega_e)$$

$$m\dot{w} = -m_z(\omega_e)\dot{w} - Z_w(\omega_e)w - Z_{\dot{\theta}}(\omega_e)\dot{\theta} - Z_{\theta}(\omega_e)\dot{\theta} - \\ - Z_{\ddot{\theta}}(\omega_e)\ddot{\theta} + Z_{FK}(\omega_e) + Z_{DF}(\omega_e) + Z_{SF} + m g$$

$$(I_{xx} + J_{xx})(\omega_e)\ddot{\phi} - (I_{xx} + J_{xx})(\omega_e)\dot{\theta}\dot{\psi} = -K_{\dot{\phi}}\dot{\phi} + \\ + (Y_v v - Y_{\dot{\psi}}\dot{\psi})Z_H + K_{FK}(\omega_e) + K_{RF} + K_{SF} + K_{DF}(\omega_e)$$

$$(I_{yy} + J_{yy})(\omega_e)\ddot{\theta} + (I_{xx} + J_{xx})(\omega_e)\dot{\psi}\dot{\phi} = -M_{\dot{\theta}}(\omega_e)\dot{\theta} - \\ - M_{\ddot{\theta}}(\omega_e)\ddot{\theta} - M_{\dot{w}}(\omega_e)\dot{w} + M_{FK}(\omega_e) + M_{SF} + M_{DF}(\omega_e)$$

$$(I_{zz} + J_{zz})(\omega_e)\ddot{\psi} - (I_{xx} + J_{xx})(\omega_e)\dot{\theta}\dot{\phi} = N_{\psi|\dot{\psi}|}\psi|\dot{\psi}| - N_{\dot{\psi}}\dot{\psi} \\ - N_v v + N_{v\dot{\psi}}v\dot{\psi} + N_{v\dot{\psi}}v\dot{\psi}^2 + N_{\dot{\psi}|\phi\phi}\dot{\psi}|\phi| + N_{DF}(\omega_e) \\ + N_{\phi}\phi - N_{\dot{v}}\dot{v} - N_{\dot{\psi}}\dot{\psi} + N_{v|\phi|}v|\phi| + (Y_{\dot{\psi}}\dot{\psi} + Y_{v|v|}v|v| + \\ + Y_{v|\dot{\psi}|}v|\dot{\psi}| - Y_v v)x_H + Y_{\psi|\dot{\psi}|}\psi|\dot{\psi}| + N_{FK}(\omega_e) + N_{RF} + N_{SF}$$

Control Systems

- Mathematical description of ship motion is important to facilitate and verify the design of the motion control systems.
- In 6-DOF mathematical models the energy from waves is distributed between the different motions which interact with each other.
- The roll motion, which is the most critical, can be simplified by one DOF equation

$$(I_{xx} + J_{xx})\ddot{\phi} + B_{xx}(\phi; \dot{\phi}) + \Delta GZ(\phi) = K_{ext}$$

To be explained later in the course
6-DOF mathematical model

$$m(\dot{u} - v\dot{\psi}) = (m_y(\omega_e) - X_{v\dot{\psi}})u\dot{\psi} - m_x(\omega_e)\dot{u} - m_z(\omega_e)\dot{\theta} + m_z(\omega_e)w\dot{\theta} + X_{FK} + X_{RF} + X_{SF} + T(1 - t_p) - R$$

$$m(\dot{v} - u\dot{\psi}) = m_x(\omega_e)u\dot{\psi} - m_y(\omega_e)\dot{v} - Y_v v - Y_{\dot{\psi}}\dot{\psi} + Y_{\dot{\psi}}\dot{\psi} + Y_{v|v|}v|v| + Y_{v|\dot{\psi}|}v|\dot{\psi}| + Y_{\dot{\psi}|\dot{\psi}|}\dot{\psi}|\dot{\psi}| + Y_{FK}(\omega_e) + Y_{RF} + Y_{SF} + Y_{DF}(\omega_e)$$

$$m\dot{w} = -m_z(\omega_e)\dot{w} - Z_w(\omega_e)w - Z_{\dot{\theta}}(\omega_e)\dot{\theta} - Z_{\dot{\psi}}(\omega_e)\dot{\psi} - Z_{\dot{\theta}\dot{\psi}}(\omega_e)\dot{\theta}\dot{\psi} + Z_{FK}(\omega_e) + Z_{DF}(\omega_e) + Z_{SF} + mg$$

$$(I_{xx} + J_{xx})(\omega_e)\ddot{\phi} - (I_{xx} + J_{xx})(\omega_e)\dot{\theta}\dot{\psi} = -K_{\dot{\phi}}\dot{\phi} + (Y_v v - Y_{\dot{\psi}}\dot{\psi})Z_H + K_{FK}(\omega_e) + K_{RF} + K_{SF} + K_{DF}(\omega_e)$$

$$(I_{yy} + J_{yy})(\omega_e)\ddot{\theta} + (I_{xx} + J_{xx})(\omega_e)\dot{\psi}\dot{\phi} = -M_{\dot{\theta}}(\omega_e)\dot{\theta} - M_{\dot{\psi}}(\omega_e)\dot{\psi} - M_{\dot{w}}(\omega_e)\dot{w} + M_{FK}(\omega_e) + M_{SF} + M_{DF}(\omega_e)$$

$$(I_{zz} + J_{zz})(\omega_e)\ddot{\psi} - (I_{xx} + J_{xx})(\omega_e)\dot{\theta}\dot{\phi} = N_{\dot{\psi}|\dot{\psi}|}\dot{\psi}|\dot{\psi}| - N_{\dot{\psi}}\dot{\psi} - N_v v + N_{v\dot{\psi}}v\dot{\psi} + N_{v\dot{\psi}\dot{\psi}}v\dot{\psi}^2 + N_{\dot{\psi}|\phi\dot{\psi}|}\dot{\psi}|\phi| + N_{DF}(\omega_e) + N_{\phi}\dot{\phi} - N_{\dot{v}}\dot{v} - N_{\dot{\psi}}\dot{\psi} + N_{v|\phi|}v|\phi| + (Y_{\dot{\psi}}\dot{\psi} + Y_{v|v|}v|v| + Y_{v|\dot{\psi}|}v|\dot{\psi}| - Y_v v)x_H + Y_{\dot{\psi}|\dot{\psi}|}\dot{\psi}|\dot{\psi}| + N_{FK}(\omega_e) + N_{RF} + N_{SF}$$

Control Systems

- ❑ Active roll stabilizer fins require a control system
- ❑ When the ship experiences external load it moves
- ❑ Gyro measures the movement
- ❑ Controller sets the stabilizing command
- ❑ Servo adjusts the fin
- ❑ Fin produces the counter force

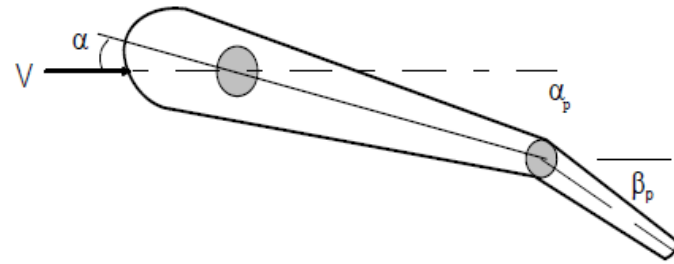
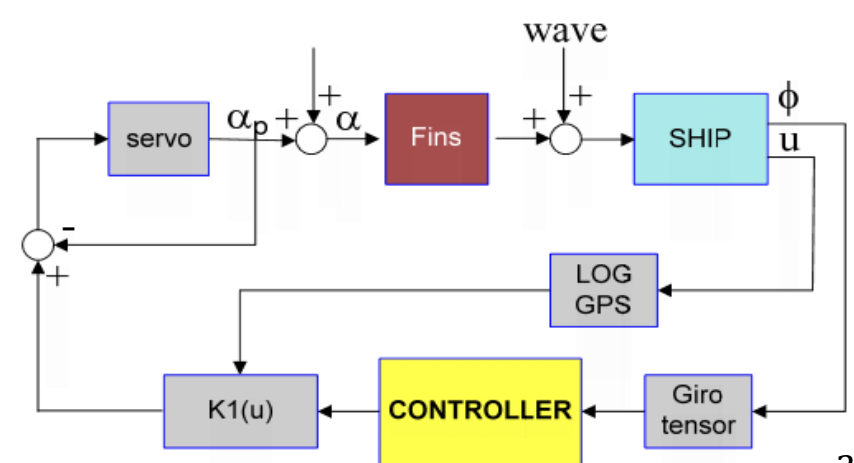

$$L = C_L(\alpha) \cdot S \frac{\rho u^2}{2}$$

$$D = C_D(\alpha) \cdot S \frac{\rho u^2}{2}$$

$$\alpha = \alpha_p + \arctan g \frac{\dot{\phi}}{u} \pm \arctan g \frac{v}{u}$$

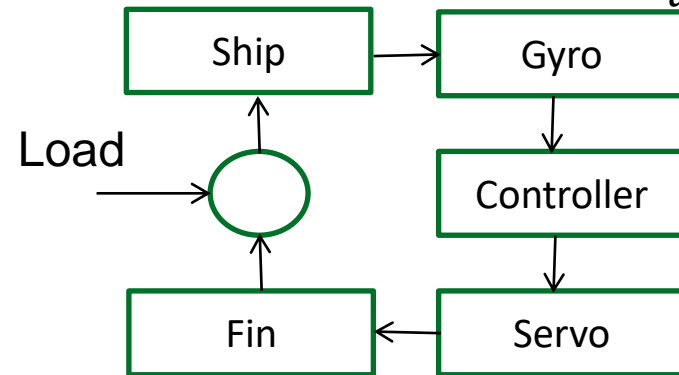

Autopilot steering

- ❑ The autopilot is an automatic control system used for automatic navigation.
- ❑ Over-reliance on it without adequate comprehension of its limitations and efficiency may cause accidents.
- ❑ The operator must understand how to set the optimal limits of:
 - ✓ the rudder angle and rate of turn
 - ✓ number of running steering gear pumps
 - ✓ off course alarm (when the ship considerably deviates from its course)
 - ✓ manual or automatic modes (depends on the traffic density)
 - ✓ speed (autopilot works efficiently in high speed)
 - ✓ weather conditions settings

An Overview of Roll Stabilizers and Systems for Their Control

K.S. Kula
Gdynia Maritime University, Poland

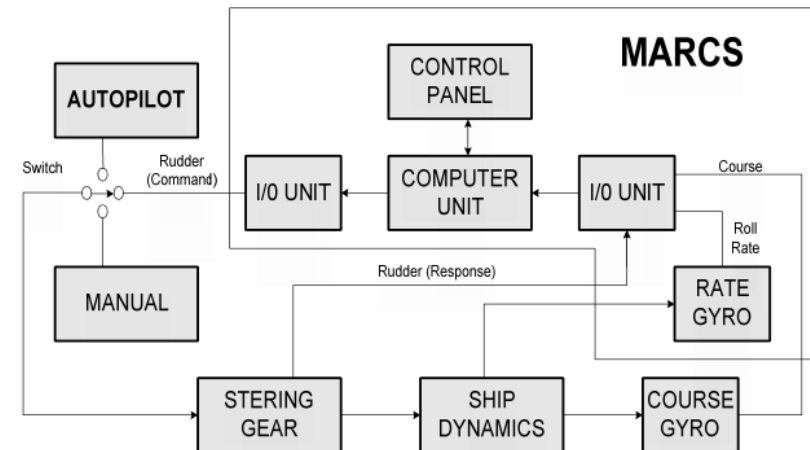

Block scheme of the rudder/roll control system.

Autopilot steering system example

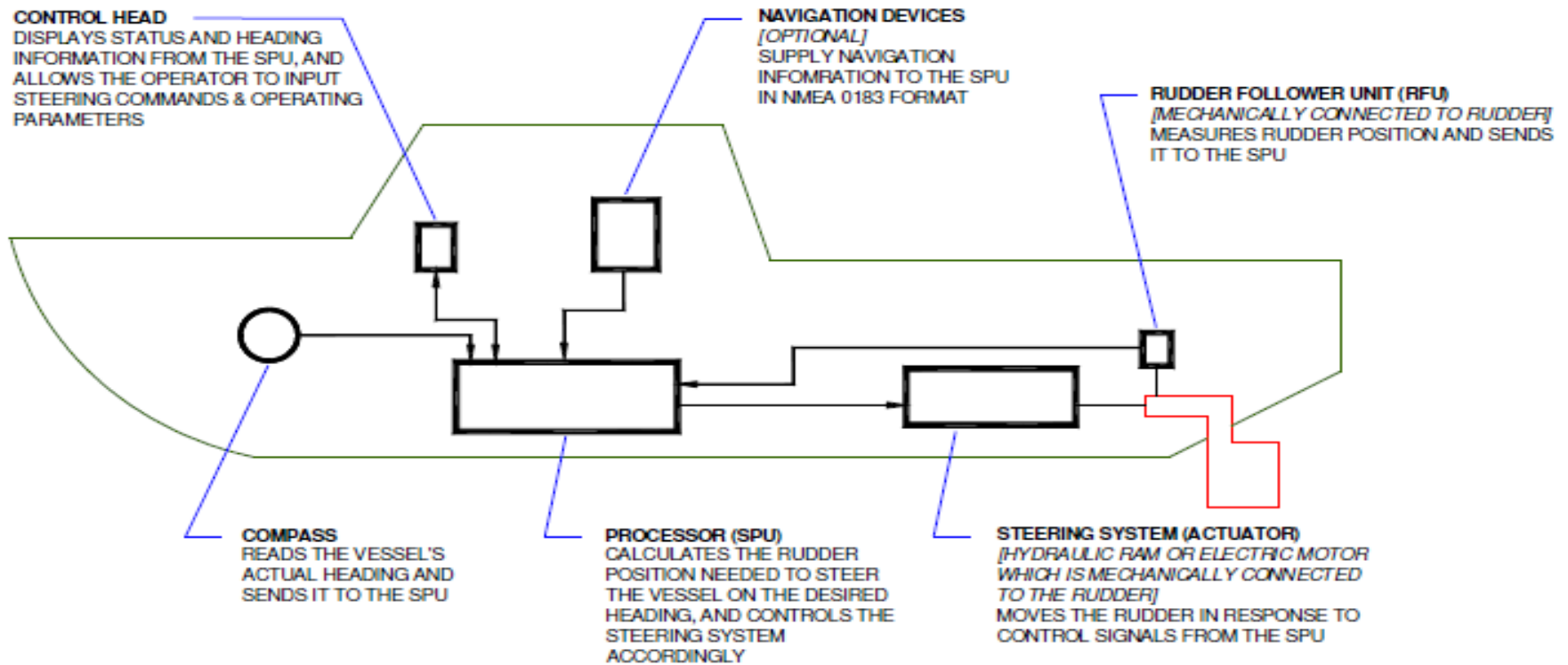

Autopilot steering system example

Simple PD-controller

- control function of the rudder angle to maintain ship's heading ψ_0 is

$$\delta_T = C_1(\psi - \psi_0) + C_2\dot{\psi}$$

- The actual rudder angle

$$\dot{\delta} = \text{sgn}(\delta_T - \delta)\omega_\delta$$

Efficient and adaptive autopilot operations

- Allow small deviations to course-line
- Decrease the fuel consumption to turn the rudder.

PID System and Track control will generate a very steady course-line; but will use excessive and large angle rudder movements to achieve this steady course-line

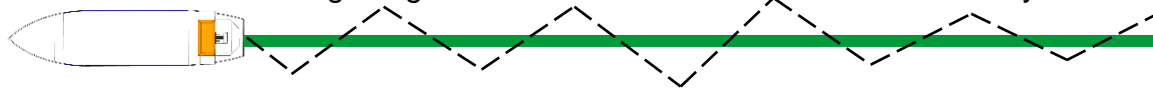

More efficient adaptive autopilot operation allows small deviation to course-line; but will use fewer and smaller angle rudder movements to maintain the course-line



Autopilot steering system example

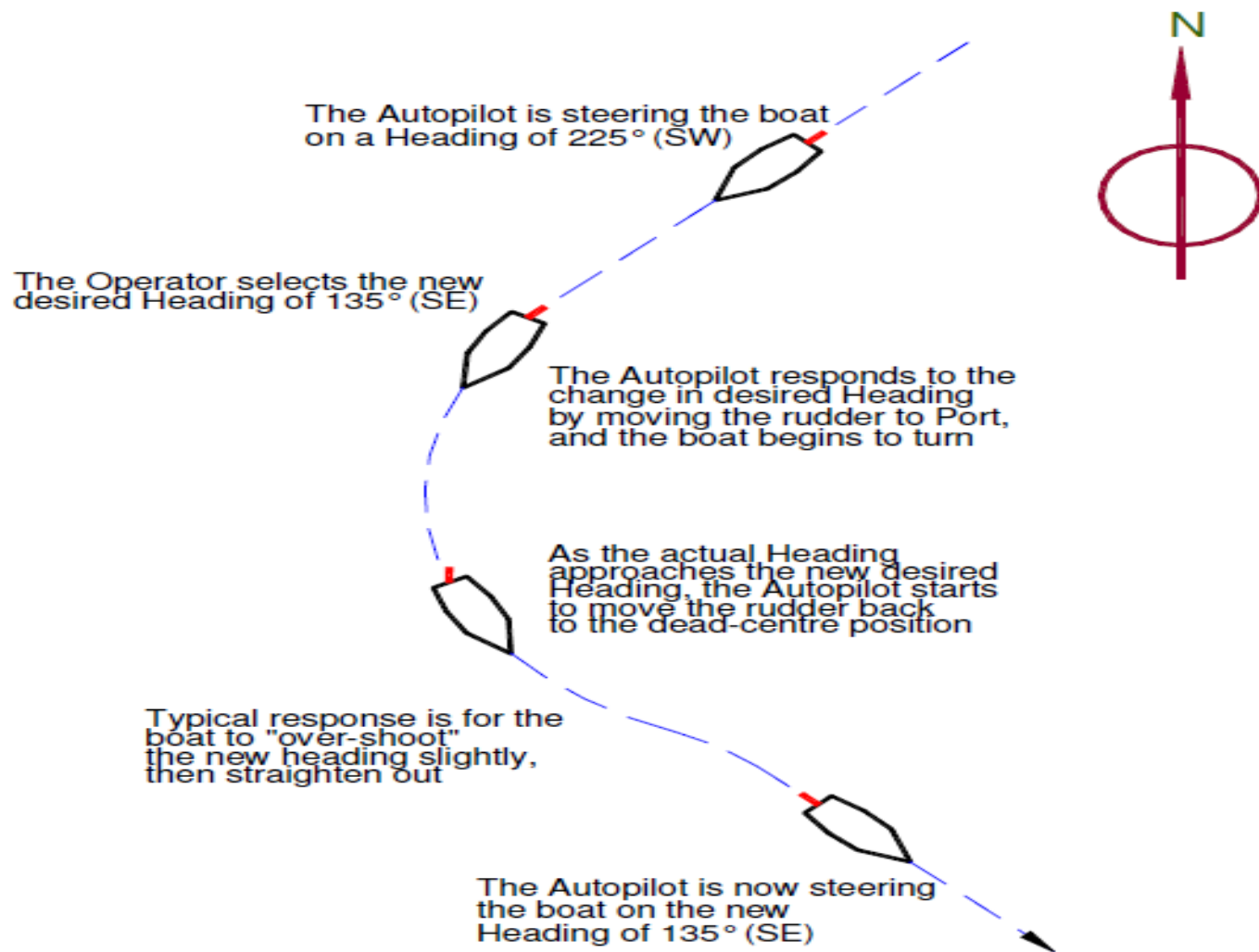

Summary

- A ship must be able to operate according to her mission
- Forces and moments emerging from different devices (e.g. propellers, rudders, pods, thrusters) are generated and affect ship dynamics.
- The hull form and her interaction with the ship propulsion systems affects ship dynamics.
- Ship motions can be controlled by different systems that affect dynamics
 - Roll damping can be controlled more easily than other motions that would require the use of heavy equipment affecting the lightship weight
 - Systems such as bilge keels, active fins, active and passive tanks may be used to control motions but each bear pros and cons depending on the type of vessel and her operating conditions.

For next time please review your knowledge on fluid mechanics and ocean waves

Thank you !!