

ELEC-C8201: Control & Automation

Lecturers: Kai Zenger, Abolfazli Elham and Valeriy Vyatkin

*Assistant (for the control part): Al Mahmud Shamsul
Assistant (for the automation part): Udayanto Atmojo,
Pranay Jhunjunwala*

*Email (control part): kai.zenger(at)aalto.fi,
elham.abolfazli(at)aalto.fi, shamsul.almahmud(at)aalto.fi*

*(automation part): valeriy.vyatkin(at)aalto.fi,
udayanto.atmojo(at)aalto.fi, pranay.jhunjunwala(at)aalto.fi*

1



Course structure and teachers

1. Control part (8 lectures, 8 exercise sessions, 8 Quizzes, 4 homework problems)

- Kai Zenger (Maarintie 8, TuAs, room 3574), distant
- Abolfazli Elham (Otakaari 5, room 1305a), distant
- Al Mahmud Shamsul, (assistant), distant

2. Automation part (4 lectures, 4 exercises, 2 homework problems. Details of the automation part will be published, when that part begins, March 15th)

- Valeriy Vyatkin (TuAs, 3575), distant
- Atmojo Udayanto, assistant, (TuAs, 3558), distant
- Pranay Jhunjunwala, assistant, distant

2

Material

The control part consists of lectures, exercise sessions, quiz problems and home assignments.

The course book (control part) is (R.C.Dorf, R.H. Bishop: Modern Control Systems, Pearson Education International, 12th edition; available in the net. Other editions are Ok also, but the section numbering etc. can then vary). Note: the book is large and is intended to be used when needed and on your own choice. It is possible to pass the course based on teaching and material given in course pages only.

Lecture slides and exercises with solutions will appear in course pages (MyCourses).

Quiz problems and homework assignments will also appear in course pages. The solutions must be submitted in due time in the portal. Quiz problems will be given once a week, homework assignments approximately every two weeks.



3



Requirements to pass the course

Final exam: Tuesday, April 12, 2022, 9:00-12:00, AS1 or distant (place to be decided based on Aalto regulations on the pandemic situation). You do not have to register to the exam, registration to the course is enough. However, for later exams (next: Monday, 16th of May 2022, 16:30-19:30) you have to register.

Homework assignments: 4 homework assignments in the control part, 2 homework assignments for the automation part. First homework will be published during the second lecture week. Solution time approximately two weeks.

Quiz problems: Each Quiz is published **24 hours before the lecture starts**, and the deadline (Quiz closes) is 15 minutes **before the lecture starts**.
Exception: The first Quiz will be published on the day of the first lecture, and the solution time is 48 hours. The Quiz problems concern the material of the previous lecture and also material on the coming lecture (lecture slides are available 24 hours before the lecture).

4



Grading

Grading is based on the following formula

$$AS\% = \frac{Quiz}{12} * 10 + \frac{Homework}{36} * 30 + \frac{Exam}{60} * 60$$

(An additional feedback bonus of 3 AS% is given to those who give feedback.)

12 Quiz problems, max 12x1=12 points

6 Homework assignments, max 6x6=36 points

Exam: 6 problems max 10 points each, max 60 points.

The weights: Quiz 10%, Homework 30%, Exam 60%

Grading: AS%: 40: 1, 50:2, 60:3, 70:4, 80:5

(if you have reached 40%, then grade is 1, etc.)

5



Schedule

January 11: Introduction, models of physical systems, Laplace transformation, Block diagram algebra, (Dorf and Bishop: Ch1, Ch2.2-2.6)

January 18: State-space representation, relation between state-space representation and transfer function (Ch 3)

January 25: Stability, poles, zeros, performance, steady-state error (Ch 5)

February 1: Routh-Hurwitz stability criterion (Ch 6.1-6.2)

February 8: The Root locus method (Ch 7.1-7.5)

February 15: Frequency response methods (Ch 8.1-8.5)

Week 8: Evaluation and examination week: no teaching in the course

March 1: The Nyquist stability criterion (Ch 9.1-9.4)

March 8: Controllability and observability (Ch 11.1-11.5)

March 15: Industrial Automation Software

March 22: Programming in IEC 61499

March 29: State machine design and implementation

April 5: Design of Automation Applications

6



Control part: Lectures and exercises

Lectures are on Tuesdays 10:15-12. Zoom link is given in MyCourses pages of the course. The same link is valid for all lectures. The lecture is also recorded and set in MyCourse pages afterwards.

Teaching starts in Zoom (distant); we follow the Aalto policy. Changes can happen. The Automation part lectures are in Teams.

The exercises are on Thursdays 10:15-12, same week as the lecture.

Separate Zoom link is provided. But: about one day before the exercise session a recording is shown, where the assistant solves the problems. The actual Zoom session, Thursday 10:15-12, is reserved for commenting the solutions and for asking questions on-line from the assistant.

Note: In the Automation part (starting 15th of March) some different teaching methods may be used. These are introduced then. However, the evaluation principles (grading) remain the same.

7

What is control?



8

8

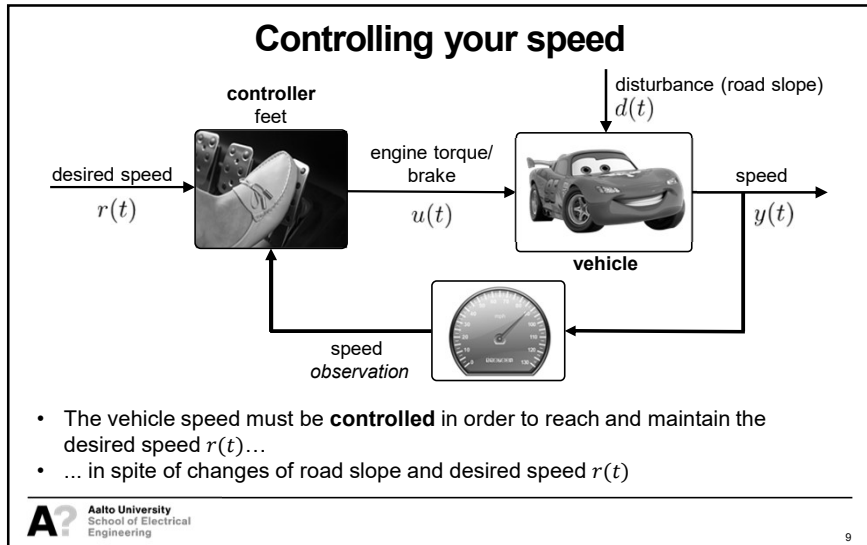

9

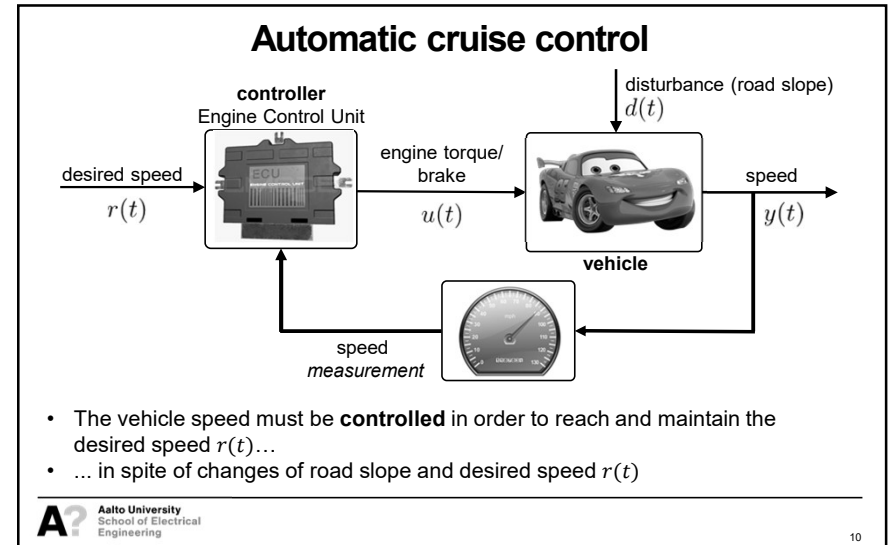

10

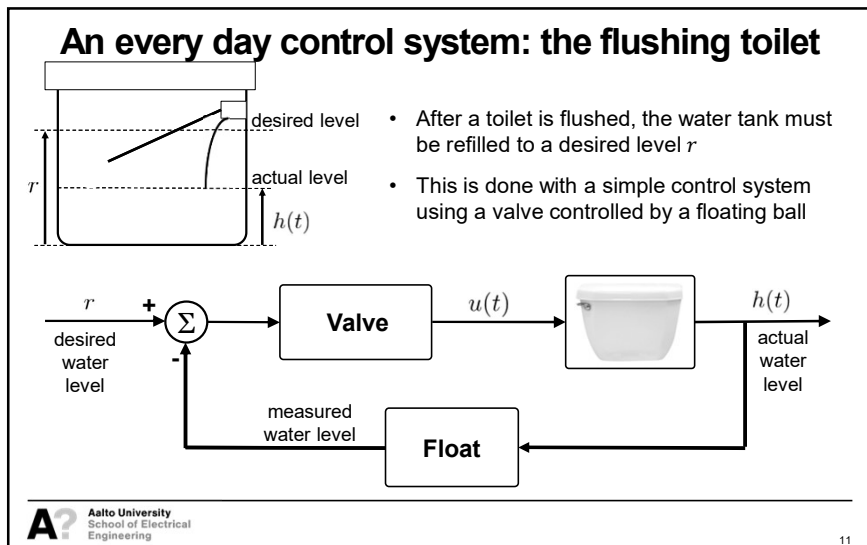

11

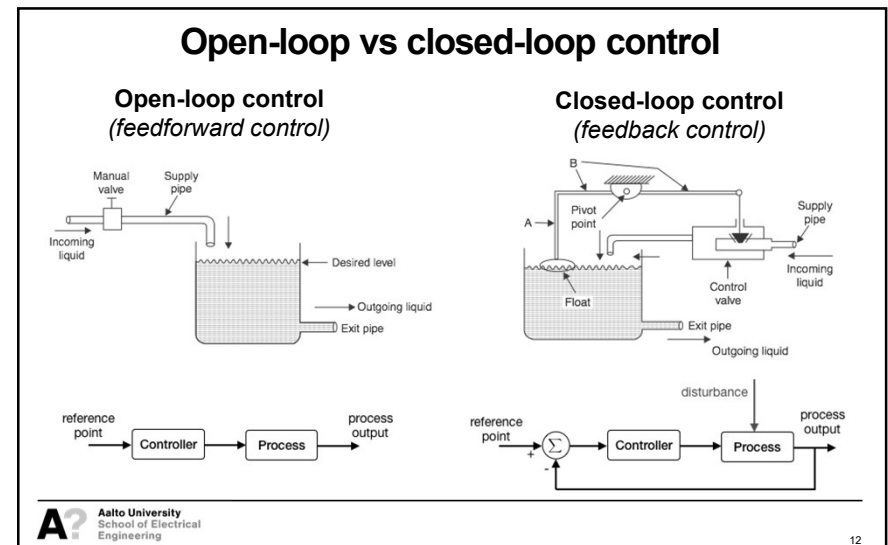

12

Application areas of control & automation

- Automotive, Aeronautics & aerospace engineering
- Process control (chemical, pharmaceutical, ...)
- Environmental systems
- Manufacturing
- Robotics
- Supply chains
- Financial engineering
- Telecommunications
- Power electronics
- Power networks
- ...



Segway Human Transporter

The Segway™ Human Transporter (HT) is the first self-balancing, electric-powered transportation device.

Dynamic stabilization enables Segway HT to work seamlessly with the body's movements.

Gyroscopes and tilt sensors in Segway HT monitor a user's center of gravity at about *100 times a second*. When a person leans slightly forward, Segway HT moves forward. When leaning back, Segway HT moves back.



Balancing a mini Segway-like robot

A project for understanding the process of:
How to design a (modern) control system?

- Understand the **automation problem**:
 - *Which variables can we control?*
 - *What are the output variables?*
 - *What should we measure?*
 - *What are the disturbances?*
- Derive a simplified **mathematical model**
- Obtain a reliable **simulation model**
- Synthesize the **control algorithm**
- **Test** in simulations, **validate** on the real system (robot)



Summary of the course

Content of the course

- **From control:**
Representations of dynamical systems (transfer functions, state-space representation), simple modeling of a dynamical system (process), the control problem, negative feedback, poles, zeros, stability, controllability, observability, PID controller, state controllers, frequency domain techniques.
- **From automation:**
This course will address the problem of how to design simple automation systems that include feedback. It includes basic structures and functions of automation systems. Sensors and automation networks. Automation programming (PLC).

Learning outcomes

- **From control:** The student
 - understands the principles and analysis methods of dynamical systems
 - can design controllers by different methods and verify the operation of the closed loop system by analytical means and through simulation
- **From automation:** The student
 - understands the hardware and software architectures of automation systems
 - can use automation programming languages of PLCs
 - designs methods and patterns learned with hands on experience

Preliminaries

- **Prerequisites:**
MATLAB, Signals and Systems, Differential calculus, Basics of computer programming, Boolean algebra, Matrix Algebra
- **Assessment methods and criteria:**
Quiz problems, homework assignments, final examination.
- **Courses where this course is a prerequisite:**
 - Digital and Optimal Control (ELEC-E8101)
 - Automation Systems Synthesis and Analysis (ELEC-E8110)
 - Distributed and Intelligent Automation Systems (ELEC-E8102), but practically we accepted there students without prerequisites.