

Concept study of wind power utilizing direct thermal energy conversion and thermal energy storage



Toru Okazaki ^{a,*}, Yasuyuki Shirai ^b, Taketsune Nakamura ^b

^a International Superconductivity Technology Center, Japan

^b Kyoto University, Japan

ARTICLE INFO

Article history:

Received 1 July 2014

Accepted 9 April 2015

Available online 14 May 2015

Keywords:

Wind power

Concentrated solar power

Thermal energy storage

Heat generator

Induction generator

ABSTRACT

Present wind power is intermittent and cannot be used as the baseload energy source. Concept study of wind power utilizing direct thermal energy conversion and thermal energy storage named Wind powered Thermal Energy System (WTES) is conducted. The thermal energy is generated from the rotating energy directly at the top of the tower by the heat generator, which is a kind of simple and light electric brake. The rest of the system is the same as the tower type concentrated solar power (CSP). The cost estimation suggests that the energy cost of WTES is less than that of the conventional wind power, which must be supported by the backup thermal plants and grid enhancement. The light heat generator reduces some issues of wind power such as noise and vibration.

© 2015 The Authors. Published by Elsevier Ltd. This is an open access article under the CC BY license (<http://creativecommons.org/licenses/by/4.0/>).

1. Introduction

Considerable amount of installation of the renewable energies to the power network arises lots of issues since the most of the renewable energies are intermittent [1]. This paper describes a novel idea named wind heat power (WTES), which is proposed for the first time, to solve the network issues.

The concentrated solar power (CSP) attracts attention because of its dispatchability. Some plants can operate continuous power generation of 24 h a day [2]. The thermal energy storage already became the second largest energy storage system in the USA after hydro. Solana, which became online since 2013, has the huge energy storage of 1680 MW-h. The sum of the thermal energy storage will become almost double in 2015 [3]. The proposals employing this practical thermal energy storage are gradually increasing [4–6]. The use of energy storage is also studied from various aspects [7,8].

Utilization of this thermal energy storage and employment of light and low cost heat generator are the key points of WTES. Typical configuration of WTES of “thermal specialized type” is shown in Fig. 1. The rotating energy is converted to the thermal

energy at the top of the tower directly. The rest of the system is the same as the tower type CSP [9]. The produced thermal energy is transferred to the base utility by the heat transfer fluid (HTF) and produces steam to drive the turbine generator when required. The total energy cost of renewable energies is mainly estimated by the following points.

- a) Efficiency
- b) Capacity factor
- c) System cost

WTES has the potential to become the most reliable and an economic power source when those are considered. The present situation of the renewable energies' installation conditions in various regions is analyzed and the merit of WTES is described in this paper.

2. Analysis of present network

2.1. Subjects of present power network

Several countries have already introduced considerable amount of renewable energies and maintain their power network in various methods [10]. The published documents issued by governments and organizations those who have responsibility to the stable power supply are studied.

Abbreviations: WTES, wind heat power; CSP, concentrated solar power; HTF, heat transfer fluid; CCGT, combined cycle gas turbine.

* Corresponding author. Tel.: +81 44 850 1612; fax: +81 44 850 1613.

E-mail address: okazakit@istec.or.jp (T. Okazaki).

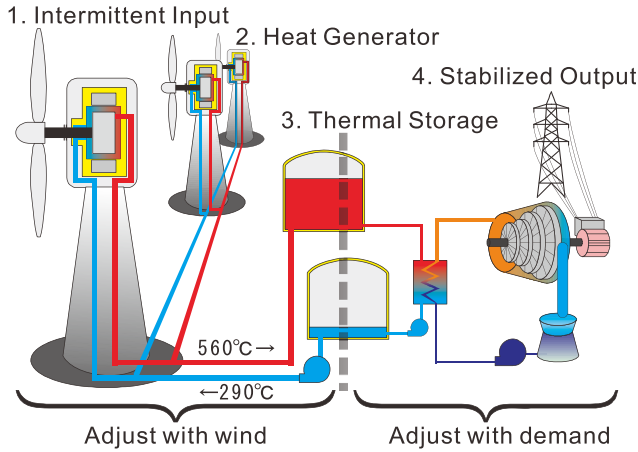

Fig. 1. Configuration of wind heat power (WTES), thermal specialized type.

2.2. Present situations of Spain and Denmark

The power network of Spain is almost isolated from the European network. Spain's wind power capacity was 2.4 GW in 2000 and it was increased to 24.8 GW in 2010. They introduced combined cycle gas turbine plants (CCGT) from 0 GW to 25.2 GW in this period [11]. It seems that their demand can be handled without renewables as shown in Fig. 2 [12].

It is said that the over 20% of the energy is supplied by the wind power in Denmark. Intimate study shows that Denmark manages their energy within Nordic energy market. Their capacity of the wind increased considerably and the capacity of the thermal plant is also slightly increased despite the amount of energy consumption in 2010 stays the same as that of the 1980. Some study claims that the energy consumption of the wind power in Denmark remains only 4% and the rest of the 16% is exported to nearby countries with low price [13].

2.3. Present status and plan of Germany [14].

German Energy Agency called dena assumes that Germany's energy consumption will decrease by 8% from 2008 to 2020. The percentage of the renewables will occupy 30% of the total electricity energy capacity in 2020 as shown in Fig. 3. The total installed capacity is increased to 25% under this condition although the total energy consumption is decreased as noted above.

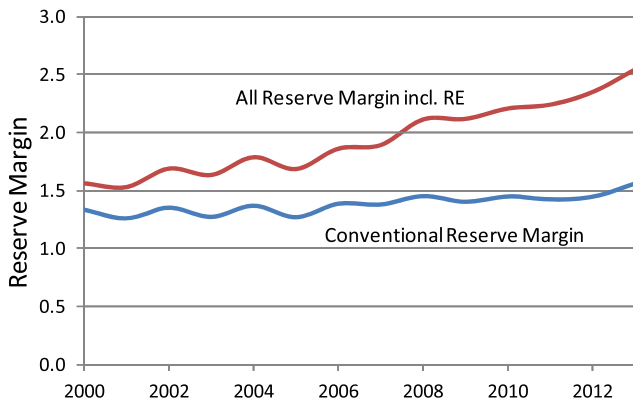

Fig. 2. Change of electricity capacity [12].

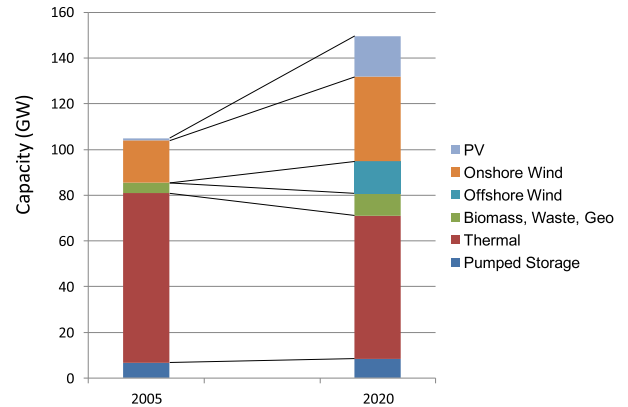

Fig. 3. Planned and installed capacity in Germany [14].

Some suggest that the output of the renewable energies becomes stable when the renewable energy sources from wide area are connected. Observed wind power of the entire German wind power shown in Fig. 4 proves this condition is not applicable to the time span of a day [15]. The conventional thermal plant must compensate the shortage of the electricity.

Another study claims that the new reserve such as CCGT is not required when the wind power is introduced in the power network by 20% [16]. Replacement of the power station, however, is necessary if the existing power stations have low output adjustability. Demand side management is not so prospective since not so many loads can wait for several days [17].

Some study shows that 90% of the backup capacity is required to introduce wind to the power network [18]. This study claims that around 20–30% of the generated power should be curtailed when the optimum network configuration is assembled. The efficiency of the backup thermal plant decreases 8% because of the intermittent operation. The total carbon dioxide reduction is slightly spoiled by this intermittent operation. DOE's simulation of 20% penetration of the wind shows 16% reduction of the carbon dioxide emission [19]. It is concluded that considerable amount of the adjustable output thermal plants are required. It should be pointed out that the frequent start-up, shutdown and adjustment of the thermal plant output make the maintenance cost increase and plant lifetime short [10].

2.4. Other means to integrate renewables

dena investigated the various systems such as pumped hydro and battery to integrate the renewables to the present network.

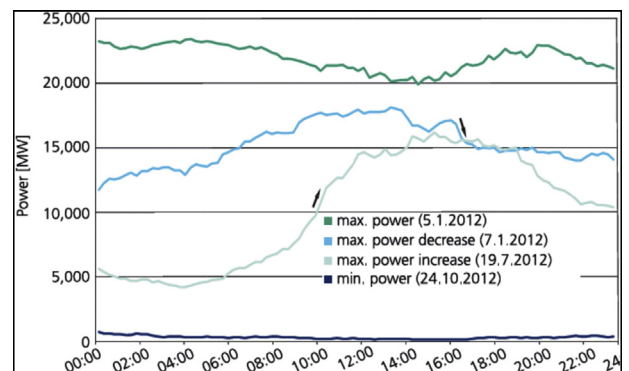

Fig. 4. Extreme Days of German Wind Power in 2012 [15].

The pumped hydro is hard to be constructed because of the geographic restrictions and environmental regulation. The batteries are not suitable to stabilize the output of the renewables in their estimation because of their cost.

Similar conclusion is stated by entso-e, European network of transmission operators for electricity [20]. DOE also has almost the same conclusion [19]. All of them also say that the grid extension is essential to achieve the integration of the renewables. In reality, the grid extension faces difficulties because of “not in my backyards” issue. The policy of DOE has changed to that the energy storage system will play a significant role consequently [21].

It is clear that backup thermal plant and/or some means of energy storage facilities are necessary to introduce intermittent renewable energies. The cost of these backup thermal plant and energy storage facilities must be counted for the energy cost of the renewable energies.

3. Overview of wind heat power (WTES)

3.1. Basic configuration

WTES, which employs low cost thermal energy storage system and light and low cost heat generator, could be a better solution than the combination of wind power and thermal plant. The possibility of becoming the low cost stable power generation is studied comparing the combination of the conventional wind with thermal backup and battery supported system.

Basic configuration of WTES is already shown in Fig. 1. The heat generator explained in the following section is employed to convert the rotating energy to the thermal energy. The heat generator has lighter weight and lower cost than that of the electric generator since the heat generator is a kind of simple brake in principle. This is important point when it comes to the gearless system, which has less breakdown possibility. The gearless system requires a heavy direct driven slow speed rotating machine.

The heat energy produced at the top of the tower is transferred to the bottom utility by the circulation of HTF. The heated HTF is stored in the thermal storage tank and brought out according to the demand to produce electricity using steam turbine. The technology of HTF circulation over 100 m is already industrialized in the tower type CSP plant, which has 140 m height with 565 Celsius maximum temperature. Even 275 m height plant is under consideration [22]. WTES is easy to be combined with other thermal plant such as CSP, geo-thermal plant and bio-mass since the energy storage and power block parts can be shared. It is, therefore, WTES is not a competing technology but a synergy technology with these technologies.

3.2. Assumption to estimate cost

Quasi-levelized cost of energy (LCOE) value is estimated to earn rough energy cost image. The lifetime, cost and efficiency are included but finance and maintenance are excluded. Very simplified wind pattern is assumed as shown in Fig. 5. The wind turbine rotates at the rated speed continuously during “a” hours in a 24 h. There is no wind rest of the day. “a/24” represent the capacity factor. The wind power plant is required to output stable electricity all day long under this condition.

The energy flow is shown in Fig. 6. The energy conversion efficiency from wind to rotating energy is abbreviated since the value is the same in every case.

The equation of stable output is derived by the following steps in the case of the battery system. DC/AC converter at the last step receives power of X/η_3 kW for 24 h when the stable output is expressed by X kW considering the DC/AC conversion efficiency η_3 .

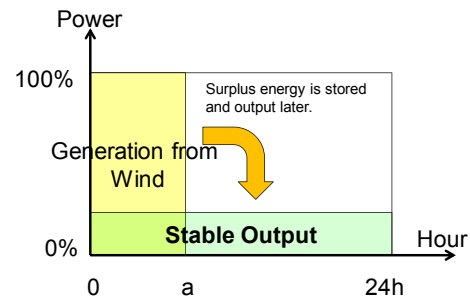

Fig. 5. Assumed operating condition.

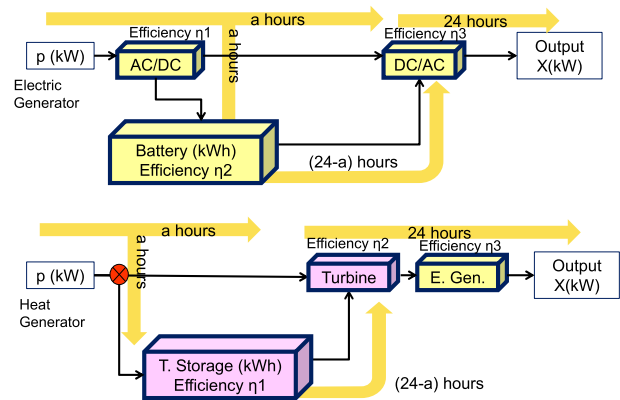

Fig. 6. Energy flow diagram. Above: conventional wind and battery, below: wind-powered thermal energy system.

The power fed to this DC/AC converter comes from AC/DC converter during “a” hours and comes from battery during the rest of the hours of (24-a) hours. The energy to the battery from the generator becomes as follows considering its efficiency of η_2 .

$$E_{to\ Battery} = (24 - a)X/(\eta_2\eta_3) \quad (1)$$

All produced energy, which is described by the multiplication of “a” hours and “p” kW, is distributed through AC/DC converter. Therefore the balance between input and output at the exit of AC/DC converter becomes

$$pa\eta_1 = (Direct\ Energy) + (Energy\ to\ battery) \\ = aX/\eta_3 + (24 - a)X/\eta_2\eta_3 \quad (2)$$

Re-arranged by the final output X of battery case becomes

$$X = p\eta_1\eta_3a/[(24 - a)/\eta_2 + a] \quad (3)$$

Almost the same equation for WTES becomes

$$X_{WHP} = p\eta_2\eta_3a/[(24 - a)/\eta_1 + a] \quad (4)$$

Multiplication of this X power and lifetime makes the total produced energy. The energy cost is delivered by dividing system cost by this energy. The wind pattern of 24 h repetition in above equation is changed to 6 h and 48 h to simulate different wind pattern.

The employed numbers are shown in Table 1. The units “kWh-t” mean energy storage by the thermal mode. The cost of tower and blade is estimated from published data [23]. Expected future cost of NaS battery is employed in Table 1. The practical NaS battery system cost including substation is 660\$/kWh, i.e. 66 k\$/kWh in the case of Long Island Bus PJ [3].

Table 1
Cost, efficiency and capacity factor of components.

Component	Cost	Efficiency	Capacity factor
Tower/Blade (Common)	90 M\2 MW	Not counted	30%
Wind	Electric Generator – 15 rpm	40 M\2 MW	93%
	AC/DC, DC/AC	20 k\kW	95%
	Transmission line	10% of kWh	Not counted
Wind + Battery	Electric Generator – 15 rpm	40 M\2 MW	93%
	AC/DC	20 k\kW	95%
	Battery (NaS)	40 k\kWh	83%
	DC/AC	20 k\kW	95%
	Transmission line	10% of kWh	Not counted
WTES	Heat Generator	20 M\2 MW	96%
	Thermal Storage	2 k\kWh-t	93%
	Steam Turbine	100 k\kWh	38%
	Electric Generator – 3600 rpm		96%
	Transmission line	10% of kWh	Not counted

The thermal energy storage cost of 2 k\kWh-t is set considering the goal of SunShot initiative, which is the project of DOE, of 15\kWh-t. The heat loss through the piping is assumed to be included in the efficiency of the thermal storage system of 93%. This value is set considering the estimated piping efficiency of the trough type and tower type CSP of 96% and 97% respectively and storage loss of 1% [24]. 100% capacity factor in Table 1, which is impractical in the real system, is introduced. The lifetime is set to short 10 years for the base case, since this calculation does not count several LCOE elements.

The cost of the conventional wind power includes the following cost.

- a) Curtailment cost of 30% [18].
- b) 30% depreciation cost of the backup thermal plant considering the capacity factor of the wind
- c) Deterioration of 8% of fuel consumption caused by intermittent operation of the thermal plant [18]. Transmission line cost is added to all cases. 10% of generated energy is counted [14]. The cost of increased maintenance of backup thermal is not counted since reliable data is not acquired.

3.3. Estimated energy cost

Estimated energy cost is shown in Fig. 7. These numbers are cheaper than Japanese average because the calculation is executed under strong Yen condition, but it is more expensive than Chinese average [25]. Three bars in each technology of “wind and backup thermal”, “wind and battery” and “WTES” show the different wind pattern of 6, 24 and 48 repetition hours.

It becomes almost double when the hidden stabilizing costs stated above are counted. This hidden cost and effectiveness of energy storage are discussed in other studies [26,27]. The energy cost of the conventional wind power stays the same when the wind pattern is changed since it does not have any energy storage.

“Wind and battery” case has strong connection with the repetition hours because the cost of the battery occupies the most of the cost. The longer repetition time requires larger energy storage capacity. This implies that the batteries are suitable for short time use. WTES has less dependency on the periodical hours. It is natural because the cost of the thermal energy storage is very cheap. This characteristic is favorable for the wind power since wind repetition time is sometimes longer than 24 h as shown in Fig. 4. The analyzed systems stated above employ gearless direct drive generator. It seems that the cost advantage of WHP is not affected by employing the geared system since the cost weight of rotating machine is relatively marginal as shown in Fig. 7.

Fig. 8 shows the case when the lifetime is set to 20 years. All elements become half of Fig. 7 automatically except the cost of backup thermal. It should be noted that several LCOE elements such as maintenance and finance are not included in this study. The different lifetime of elements employed in the system must be also considered. The lifetime of tower is much longer than 20 years, for example. It seems that WHP has the potential to become the most economic system even if WHP is compared with the present system, which consists of combination of conventional wind and backup thermal, in conclusion.

3.4. Comparison with electric heater system

Stabilization of the intermittent wind power can also be realized by the combination of the conventional wind power and an electric heater [6]. This system becomes superior compared with WTES when the total system capacity becomes small. It is explained as follows. The system cost of electric machines has little connection

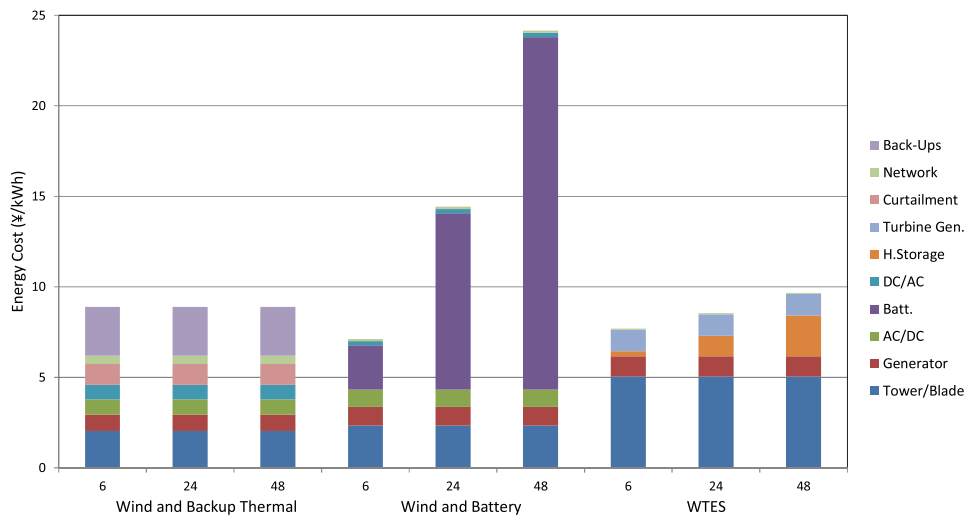

Fig. 7. Estimated Energy Cost. Different repetition time of 6, 24, 48 h.

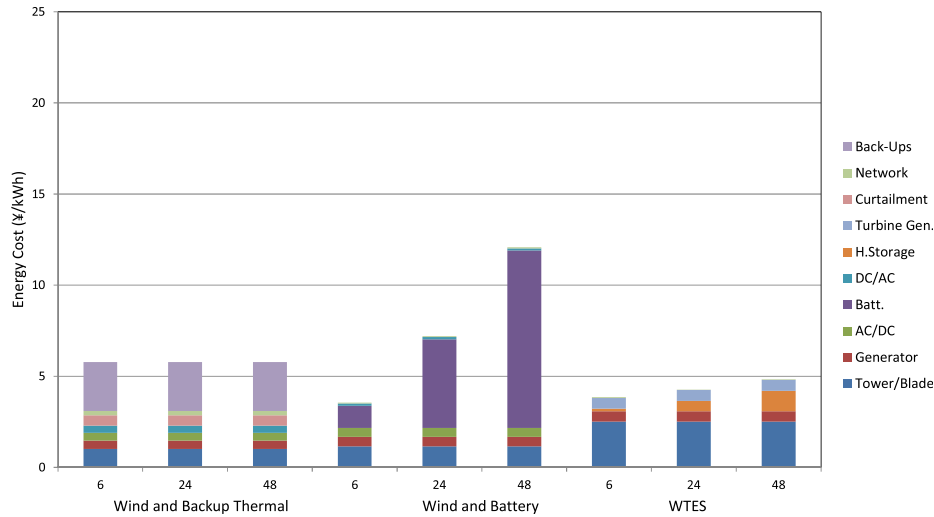

Fig. 8. Estimated Energy Cost. Lifetime of 20 years case.

with the system capacity. On the other hand the system cost of the thermal machines depends on the system capacity. The cost of the thermal machine increases by the power of 0.6–0.7 when the system capacity is increased considering scale up factor [24].

The cost estimation curve of HTF system is shown in Fig. 9 using CSP study of 470 MW system [28]. The line of the “heater cost” includes the heater cost, electric converter cost and the cost difference between the electric generator and heat generator. WTES has advantage over the combination of the heater and electric generator system over sub-MW, which is the major size of the conventional wind power. This condition is changed when the system configuration is changed. The direct thermal energy use such as hot water supply has the different cost structure, for example.

4. Heat generator

4.1. Example of heat generator

There are several methods that convert rotating energy to thermal energy. Typical methods are;

1. Friction between solid materials
2. Agitation of fluid
3. Electromagnetic induction

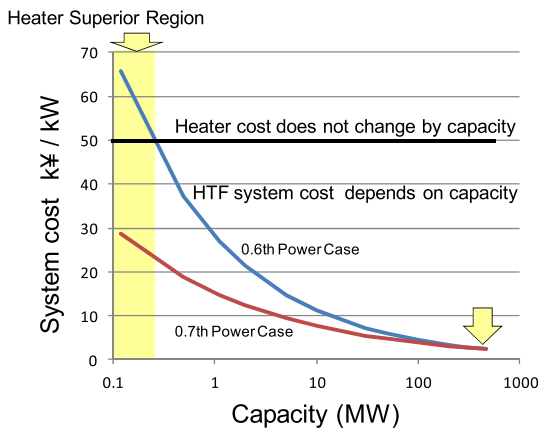

Fig. 9. Cost tendency of HTF and heater System.

The friction system needs frequent maintenance and replacement of parts. The agitation of fluid may not require frequent maintenance like the friction but the produced temperature is restricted by the characteristics of the fluid.

It seems that the use of the electromagnetic induction is the best method to convert the rotating energy to the thermal energy. The most simplified principle of the electromagnetic induction heating is shown in Fig. 10. The static magnetic field is impressed over the conductor. The eddy current is induced and heats up the conductor when the conductor is forced to rotate.

The retarder, which is widely employed for auxiliary brake of the heavy vehicles, is one of the promising technologies for the heat generator. The temperature of the retarder reaches over 600 Celsius although the temperature of the equipped permanent magnet stays under 100 Celsius. The capacity of the retarder is around several hundred kW, which is close to the popular wind turbine's capacity of 2 MW. The weight of the retarder is almost one-tenth of the electric motor/generator of the same capacity. The retarder has already enough robustness since it is designed to stand for intermittent load, snow, heat, salt and humidity [29].

4.2. Heat transfer from heat generator

Elemental consideration about the heat transfer condition from the heat generator is checked. The conventional permanent magnet direct drive generator for the wind power of 2 MW 3800 mm diameter is selected for the provisional estimation. It is assumed that all produced energy is converted to the thermal energy in the armature. The slot and winding configurations are kept the same. The pass of the HTF of water with 300 Celsius and 15 MPa is placed in the armature winding. The total heat transfer area is assumed 57.7 m² and the heat flux becomes 38 kW/m². When the condition

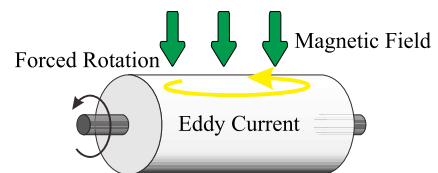

Fig. 10. Principle of heat generator.

of pressurized water of the nuclear reactor's inlet/outlet water temperature of 293 and 325 Celsius respectively is applied, which is very conservative conditions, required mass-flow of water become 16.4 kg/s and 0.425 m/s. Those figures are reasonable numbers. The employment of other HTF such as molten salt enables much room for design since the inlet/outlet temperature can be set to 290 and 560 Celsius respectively.

4.3. Various usage of induction machine

4.3.1. Induction machine for heat generator use

It is well known that there is no difference between the induction motor and generator in nature. Typical torque curve is shown in Fig. 11. It becomes the strong electric brake, i.e. the heat generator, when DC current is fed to the armature and the rotor is forced to turn ($S = 1$ or -1 in Fig. 11). This large torque enables low rotating speed operation and small noise. Absorbed energy is dissipated as the thermal energy in the cage-type conductor. The canned motor structure is employed to remove this thermal energy. This canned motor can stand for 450 Celsius [30].

4.3.2. Induction machine for E-H generator use

The induction machine can be used as the electric and heat generator (E-H generator) when the full bi-directional AC/DC converter is employed. The maximum torque, which is several times larger than the rated torque, is called stalling torque. Continuous operation under the stalling torque results in enormous heat generation in the generator. The conventional generator cannot be used in this condition. E-H generator can be used in this condition since it is equipped with the heat transfer system. E-H generator produces electricity and heat by controlling the phase of the excited field.

On the other hand, E-H generator has to keep complicated three phase windings. The weight and cost of E-H generator are heavier and higher respectively than the simple heat generator although lighter than the conventional induction generator. The estimation of the resulted energy cost is difficult, because of many elements such as wind condition, demand curve of the considering area, trade price, system cost, efficiency and capacity factor. Superiority of E-H generator system against simple heat generator system depends on the local conditions such as wind pattern.

4.3.3. Surplus energy absorption of the grid

E-H generator can convert surplus energy in the grid to the thermal energy for later use as shown in Fig. 12. Economic feasibility study is also difficult since various aspects affect. This surplus

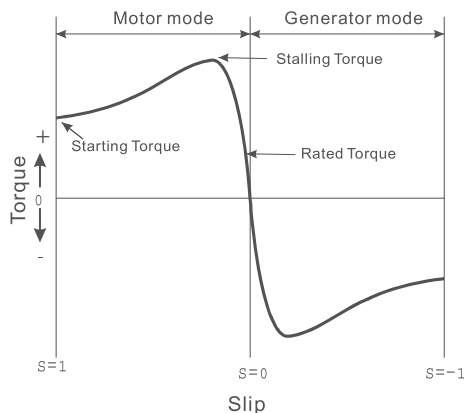

Fig. 11. Characteristics of induction machine.

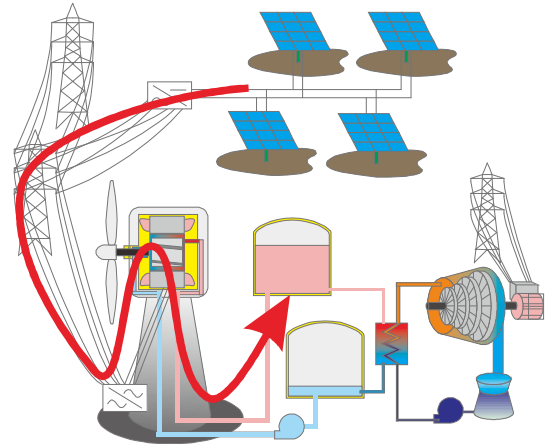

Fig. 12. Surplus energy absorption.

energy absorption is also conducted by CAES. CAES has several restrictions such as requirement of underground cavern and supply of natural gas. WTES has fewer restrictions than CAES does.

4.4. Superconducting heat generator

The higher efficiency of the turbine generator is realized when the working gas temperature becomes high. On the other hand, steel loses its magnetization over Curie temperature, which is around 800 Celsius. The superconducting magnet can produce strong magnetic field without magnetic material. HTS induction heating machines for aluminum are commercialized [31].

Air may be employed as HTF for this high-temperature heat generator. Air circulation system at 1100 Celsius for CSP is already proposed [32]. The efficiency improvement is expected to outstrip the system cost increase and reduces the energy cost.

This high temperature realized by employing superconducting magnet leads another possibility of WTES. Various thermo-chemical reactions, such as refinement of natural gas, production of ammonia and hydrogen production are realized by this high temperature [33,34].

5. Merits of WTES other than the cost

WTES has some merits other than the cost merit stated above. These are summarized below.

- a) Full energy harvest from the physical wind power
- b) Low environmental impact
- c) Effects on local economy
 - a) Conventional wind power firms have to keep the stable output during the designated duration, typically 30 min, to maintain the stability of the power network. Short of the output is charged to the wind firms. This means that the output of the wind power is always below the wind's physical power at the wind tower to prevent the charge. Exceeded wind's physical power, which is expressed in Fig. 13 by hatched portion, is curtailed. WTES can crop maximum energy, which is within Betz's law, from the wind since the cropped energy is not converted to the electricity directly. Strong wind energy in midnight can also cropped for later use. Cut-off wind speed is although enlarged when the capacity of the wind power is restricted by the generator capacity since the heat generator can be higher torque with small increase of weight.

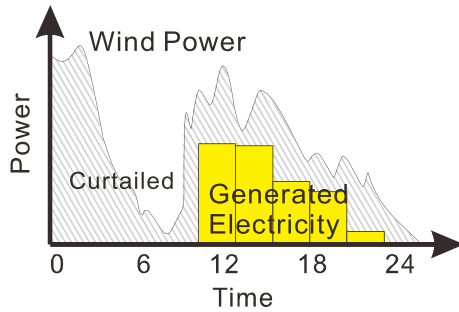

Fig. 13. Generated electricity and physical wind power at wind tower.

- b) All kinds of utilities have to consider demolition. Most bulky material used in WTES is the thermal storage medium, which consists of nitrates. The nitrates are well known as raw material for the fertilizer. Few hazardous chemical materials are employed in WTES. WTES enables low rotation speed of the blades because of the torque-full light heat generator. This leads to low noise and low vibration. The gear-less system, which is reliable and silent, can be realized with reasonable cost by the heat generator.
- c) Many elements employed in WTES can be procured locally since the elements employed in WTES are categorized to a kind of “low-tech” things. The most bulky material for the thermal energy storage can be procured locally when the solid type thermal energy storage system is employed. Construction and maintenance work enlarges local employment and economy.

6. Conclusion

The backup thermal plants or some kind of energy storage systems are essential when considerable amount of wind power is introduced to the grid. The energy costs of the wind with backup thermal, the wind with battery energy storage and Wind Powered Thermal Energy System (WTES), which employs heat generator and thermal energy storage system, are compared first-ever. It seems WTES becomes the most economical system in these three systems although the estimation is in the initial stage. WTES becomes much more attractive when it is constructed besides CSP and/or bio-mass plant since many parts of elements can be shared. The configuration of WTES has many variations. Employment of the electric and heat generator enables flexible operation. It can even absorb surplus energy in the grid. Employment of the superconducting heat generator realizes high working temperature, i.e., high thermal to electric conversion efficiency. Those variations including simple thermal specialized type have lots of room to be investigated.

Acknowledgment

Authors owe a very important debt to President Izumi Ushiyama of Ashikaga Institute of Technology, Prof. Akihiko Yokoyama of University of Tokyo, Prof. Tetsuji Matsuo of Kyoto University. This work was supported by JSPS KAKENHI Grant Number 26630118.

References

- [1] Arita M, Yokoyama A, Tada Y. Evaluation of battery system for frequency control in interconnected power system with a large penetration of wind power generation. In: Int Conf On Power System Tech; 22–26 Oct., 2006 [Chong qing, Chi].

- [2] Rinaldi F, Binotti M, Giostrì A, Manzolini G. Comparison of linear and point focus collectors in solar power plants. *Energy Procedia* 2014;49:1492–500.
- [3] DOE global energy storage database, <http://www.energystorageexchange.org/projects> [Retrieved 20/01/2015].
- [4] Thess André. Thermodynamic efficiency of pumped heat electricity storage. *Phys Rev Lett Sep.* 2013;111:110602.
- [5] European Patent EP1 577 548 A1 “Apparatus and method for storing thermal energy and generating electricity”.
- [6] U.S. Patent Appl US2012/0326445 A1 “On-demand generation Electr stored wind energy”, Published Dec. 27, 2012.
- [7] Barnhart Charles, Dale Michael, Brandt Adam, Benson Sally. The energetic implications of curtailing versus storing solar- and wind-generated electricity. *Energy Environ Sci Jun.* 2013;2804–10.
- [8] Sioshansi Ramteem, Denholm Paul. Benefits of co-locating concentrating solar power and wind. *IEEE Trans Sustain Energy Oct.* 2013;4(4):877–85.
- [9] Dunn Rebecca, Hears Patrick, Weight Matthew. Molten-salt power towers: newly commercial concentrating solar storage. *Proc IEEE* 2012;100(2): 504–15.
- [10] IEA Projected Costs of Generating Electricity 2010 Edition, p144–146.
- [11] Lorubio Giuseppe. Flexible generation: backing up renewable. *Union of the Electricity Industry – EURELECTRIC*; Oct. 2011. p. 26. Dépôt légal: D/2011/12.105/47.
- [12] Statistical Series of RED Elctrica <http://www.ree.es/en/publications/indicators-and-statistical-data/statistical-series> (Retrieved 22/12/2014).
- [13] CEPOS. Wind energy—the case of Denmark. Center for Polotiske Studier; Sep. 2009. p. 25.
- [14] dena. Dena grid study II—integration of renewable energy sources in the German power supply system from 2015–2020 with an outlook to 2025. German Energy Agency; Apr. 2011.
- [15] Fraunhofer IWES, “Wind energy report Germany 2012” p17.
- [16] European Wind Energy Association. Powering Europe: wind energy and the electricity grid. Nov. 2010.
- [17] Göransson Lisa, Johnsson Filip. Large scale integration of wind power in thermal power systems. *Wind power*, ISBN 978-953-7619-81-7. p. 479–98.
- [18] Hoogwijk M, Vuuren Detlev, Vries Bert, Turkenburg Wim. Exploring the impact on cost and electricity production of high penetration levels of intermittent electricity in OECD Europe and the USA, results for wind energy. *Energy* 2006. <http://dx.doi.org/10.1016/j.energy.2006.09.004>.
- [19] U.S. Department of Energy. 20% wind energy by 2030. DOE/GO-102008–2567. Jul. 2008. p. 80. p.162.
- [20] ENTSO-E. Ten-year network development plan 2010–2020. June 28, 2012. p. 146.
- [21] U.S. Department of Energy. Grid energy storage. December 2013.
- [22] Kolb Gregory. An evaluation of possible next-generation high-temperature molten-salt power towers. SANDIA REPORT SAND2011–9320. Dec. 2011. p. 20.
- [23] Krohn Soren, Morthorst Poul, Awerbuch Shimon. The economics of wind energy. A report by the European Wind Energy Association. Mar. 2009. p. 37.
- [24] Sargent & Lundy LLC Consulting Group. Assessment of parabolic trough and power tower solar technology cost and performance forecasts. NREL/SR-550-34440, 4–5. Oct. 2003.
- [25] China wind power industry drowned in recession (Japanese) <http://time-az.com/main/detail/34635> (Retrieved 26/01/2015).
- [26] Mount T, Lamadrid A, Maneevitjit S, Thomas B, Zimmerman R. The hidden system cost of wind generation in a deregulated electricity market. In: Proceedings of the 43rd Hawaii international conference on system sciences (HICSS-43). IEEE Computer Society; Jan. 2010.
- [27] Taylor G, Tanton T. The hidden costs of wind electricity. American Tradition Institute; Dec. 2012.
- [28] Kolb Gregory, Ho Clifford, Mancini Thomas, Gary Jesse. Power tower technology roadmap and cost reduction plan. SANDIA REPORT SAND2011–2419. Apr. 2011. p. 17.
- [29] Noguchi Y, Miyahara M, Imanishi K, Saitoh A, Kishine N. Creep-fatigue prediction for permanent magnet type eddy current retarder. *Fatigue* June 2002;5(5):3101–8.
- [30] G. Feldle “Canned motor pumps for high temperature applications in solar thermal power stations”, Technical report, HERMETIC-Pumpen GmbH Gundelfingen.
- [31] Runde M, Magnusson N, Fülbier C, Bührer C. Commercial induction heaters with high temperature superconductor coils. *IEEE Trans Appl Supercond* 2011;21:1379–83.
- [32] Stefano G, Buck Reiner, Eguiguren Santiago. Analysis of solar-thermal power plants with thermal energy storage and solar-hybrid operation strategy. *Trans ASME N Journal Sol Energy Eng* 2011;133(3):031007.
- [33] Steinfeld Aldo, Palumbo Robert. In: Meyers RA, editor. *Solar thermochemical process technology*, Vol. 15. Academic Press; 2001. p. 237–56.
- [34] Pitchumani R, editor. *Concentrating solar power program review 2013*; Apr. 2013.