

You should not copy paste material directly from the course material or any other source available electronically when answering the questions. Only data sheets are accepted if they are necessary to explain your numerical answer.

1. Explain shortly (2...4 sentences + possible drawing), what the following terms mean
 - Miller effect
 - Reverse recovery charge
 - SOA
 - Prospective short-circuit current
 - ESR.
2. Describe the construction, functioning principle and properties of IGBT.
3. Discuss filters used for the filtering of EMC, their operating principles and components used.
3. A three-phase full-wave diode rectifier package consists of six diode dies within a single module. DC load current of the rectifier is 100 A and it is assumed to be constant because of the high DC side inductance. The diode on-state voltage is 1 V when it is conducting. The junction-to-case thermal resistance of each die is 0,24 K/W. The module is mounted on a heatsink with a module-to-heatsink contact thermal resistance of 0,2 K/W and a heatsink-to-ambient thermal resistance of 0,1 K/W. The maximum ambient temperature is 30°C.
 - a) Calculate the diode junction temperature.
 - b) The rectifier lifetime will double when the junction temperature decreases by 10 °C. What is the allowed load current in this case?
 - c) If the load current remains at 100 A, what is the needed heatsink when double lifetime is required., i.e. 10 °C lower junction temperature as in a).
5. A step-down dc-dc converter has an inductor made from ferrite toroid TN26/15/10-3C90. When the converter switch is on, there is a 19 V voltage over the inductor for the period of 10 μs and inductor current should increase from zero to 0,5 A peak value during this time.
 - a) How many turns you need to build the required inductance?
 - b) What is the maximum flux density in the core?
 - c) Is this ferrite toroid suitable for the purpose? Give reasoning for your answer, yes or no is not enough.

RING CORES (TOROIDS)**Effective core parameters**

SYMBOL	PARAMETER	VALUE	UNIT
$\Sigma(I/A)$	core factor (C1)	1.08	mm ⁻¹
V_e	effective volume	3360	mm ³
l_e	effective length	60.1	mm
A_e	effective area	55.9	mm ²
m	mass of core	≈ 17	g

Coating

The cores are coated with polyamide 11 (PA11), flame retardant in accordance with "UL 94V-2"; UL file number E 45228 (M).

The colour is white.

Maximum operating temperature is 160 °C.

Isolation voltage

DC isolation voltage: 2000 V.

Contacts are applied on the edge of the ring core, which is also the critical point for the winding operation.

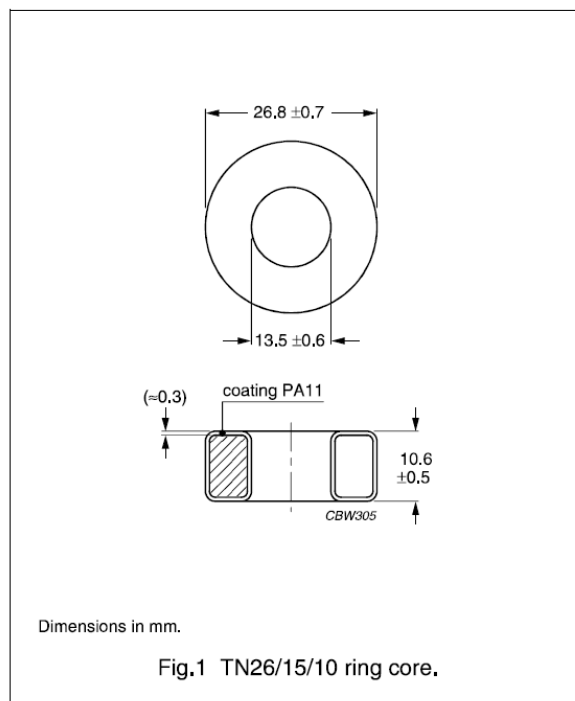
**Ring core data**

GRADE	A_L (nH)	μ_i	TYPE NUMBER
4A11	817 ± 25%	≈ 700 ⁽¹⁾	TN26/15/10-4A11
3C90	2645 ± 25%	≈ 2300	TN26/15/10-3C90
3C11	5000 ± 25%	≈ 4300	TN26/15/10-3C11
3E25	6420 ± 25%	≈ 5500	TN26/15/10-3E25

1. Old permeability specification maintained.

Properties of cores under power conditions

GRADE	B (mT) at	CORE LOSS (W) at	
	H = 250 A/m; f = 25 kHz; T = 100 °C	f = 25 kHz; B = 200 mT; T = 100 °C	f = 100 kHz; B = 100 mT; T = 100 °C
3C90	≥ 320	≤ 0.38	≤ 0.38