

**CHEM-E0115 Aalto Course: Plant
Engineering
Lecture 5**

Mechanical and Piping

**Tuomas Kuusikko
6.10.2022**



**Aalto University
School of Chemical
Engineering**



- Tuomas Kuusikko
- Masters' degree in Mechanical Engineering (Tampere University of Technology)
 - Major paper technology
- Approximately 20 years' experience of industrial sectors.
- At the moment I´m responsible for the management of the mechanical and piping lead engineering team.
- Current position: Director, Mechanical & Piping

Tuomas Kuusikko

Director, Mechanical and Piping

M: +358 505758745

tuomas.kuusikko@afry.com

AFRY

P.O. Box 4, 01621 Vantaa, Finland

Visit: Jaakonkatu 3, 01621 Vantaa Finland

3D Plant Engineering Views



<https://www.metsagroup.com/fi/metsafibre/metsafibre/sellun-tuotanto/kemin-biotuotetehdas/>

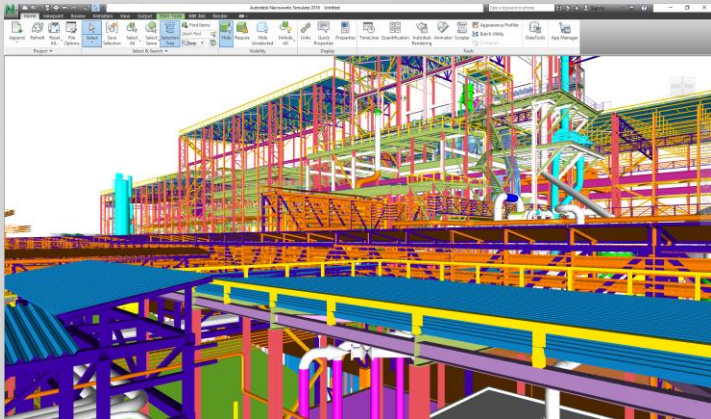
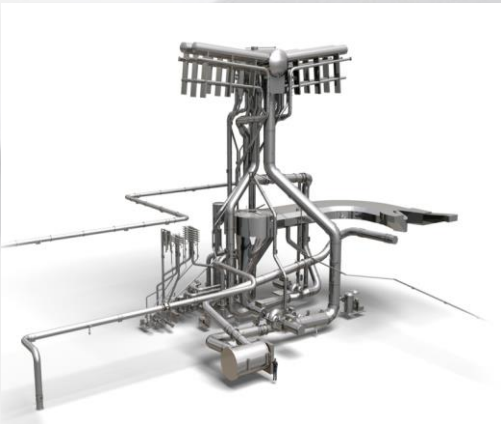
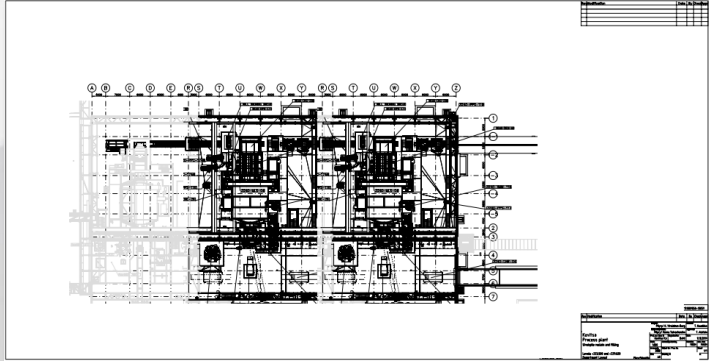
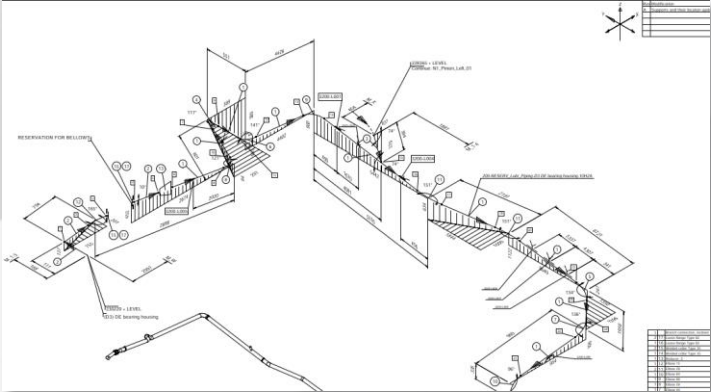

Plant Engineering Interfaces

Plant Engineering is the combination of models, drawings, specifications and material take-offs are needed for the implementation of a plant project phase.

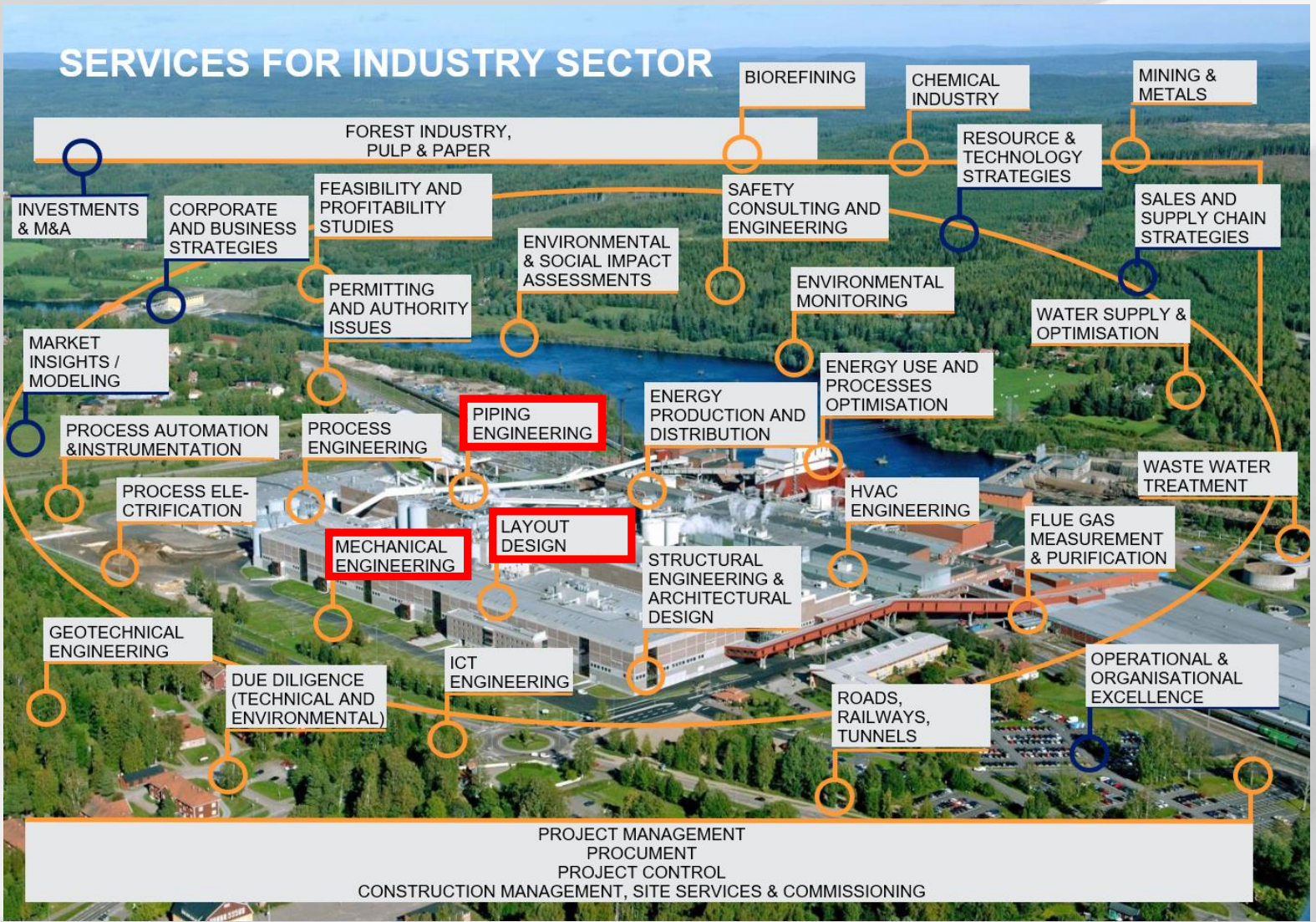

Plant engineering, things to consider in the mechanical and piping engineering

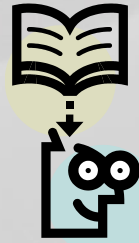

Standards

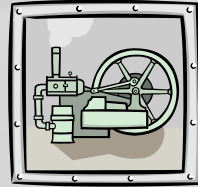

Eq suppliers



Process



CLIENT & Budget



Safety at Work



Inspection authorities



Laws & Directives



Schedule



Architects



Electrical & Automation

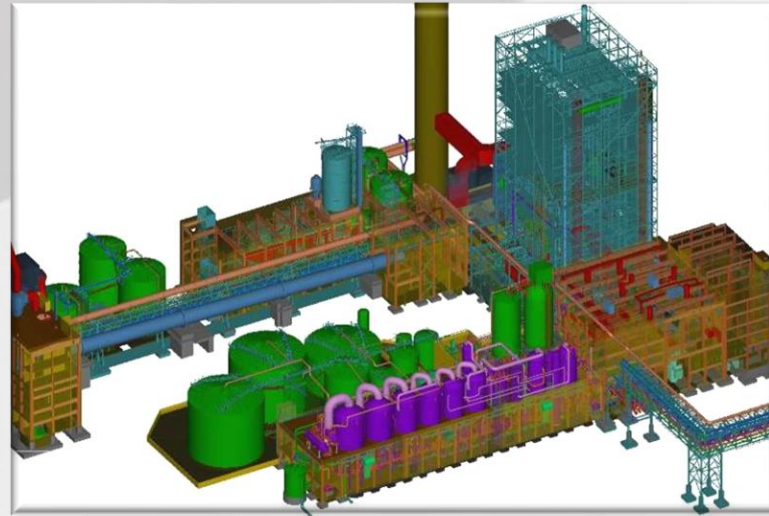

Fire & General Safety



Building

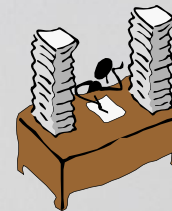

Documentation



Manufacturing & Erection



PROJECT ORGANISATION CHART

Sample only

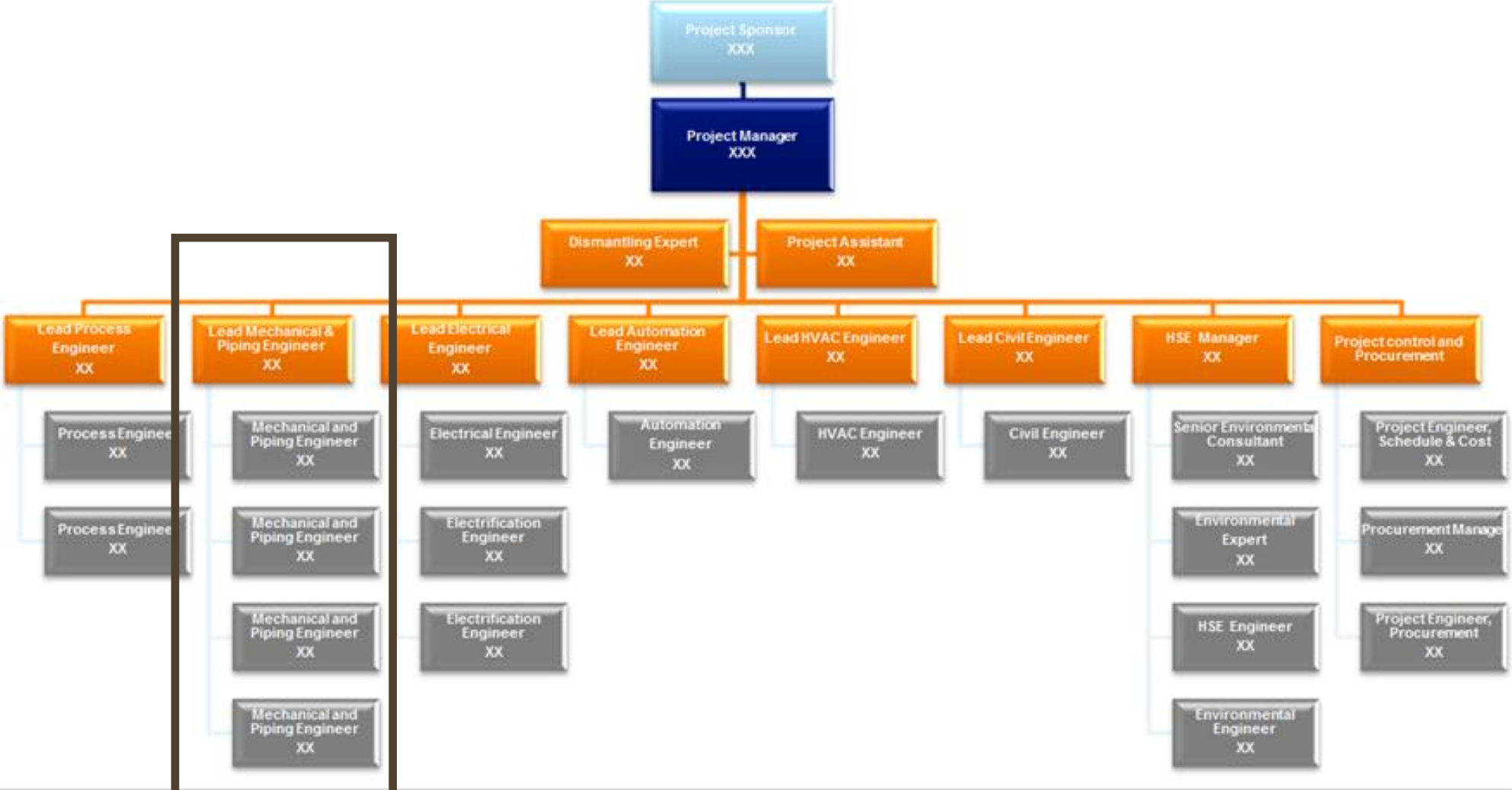

Table of Content:

1. Mechanical and piping engineering: general 1/3
Mechanical and piping engineering: general 2/3
Mechanical and piping engineering: general 3/3
2. Project Workflow: engineering project phases
 - 2.1 Estimated accuracy of investment cost by project phase
3. Mechanical and Piping FEL1/FEL2 Phase
 - 3.1 Mechanical and Piping FEL1/FEL2 Phase Deliverables
4. Mechanical and Piping FEL2/FEL3 Phase
 - 4.1 Mechanical and Piping FEL2/FEL3 Phase Deliverables
5. Example drawings before detail engineering has started
 - 5.1 Example material take-off's and cost estimation before detail engineering has started
6. Execution/Detail Engineering Phase
 - 6.1 Mechanical
 - 6.2 Piping Engineering
7. Detail engineering tasks: Mechanical Engineering
 - 7.1 Detail engineering tasks: Piping Engineering (1/2)
 - 7.2 Detail engineering Tasks: Mechanical and Piping Specifications and Standards
8. Summary

1. Mechanical and piping engineering: general 1/3

Common mechanical tasks during the project:

- Layout engineering → e.g. create 3D model and layout drawings
- Equipment engineering → e.g. create 3D model and equipment outline drawings
- Standards and specifications → e.g. create new specifications or update existing
- Technical calculations → e.g. tank calculations

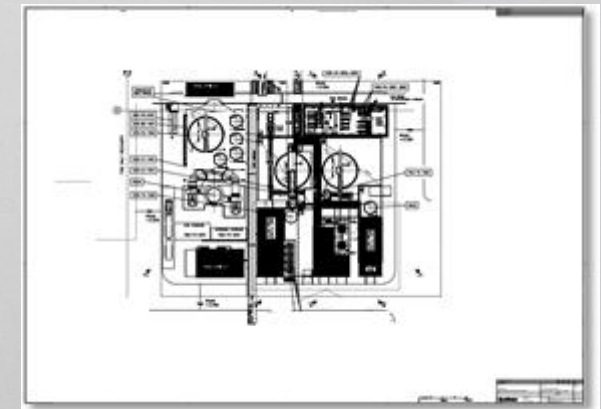
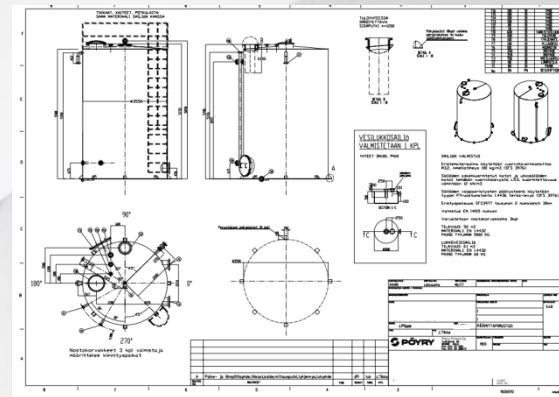

1. Mechanical and piping engineering: general 2/3

Common piping engineering general tasks during the project:

- Standards and specifications → e.g. create technical specifications for piping, valves, etc.
- Piping route design → e.g. create material take off lists, isometric drawings
- Piping support design → e.g. create piping support drawings
- Technical Piping calculations → e.g. create piping stress calculations

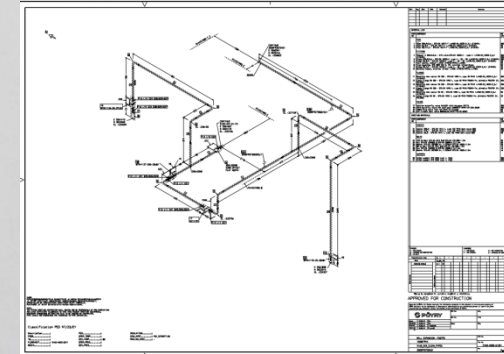
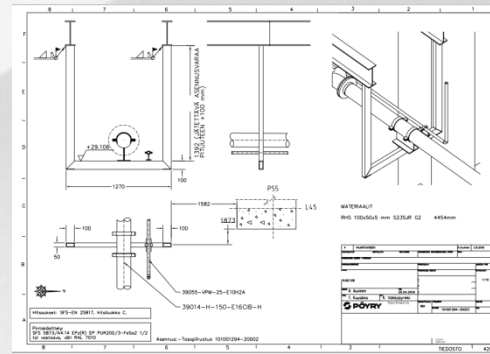
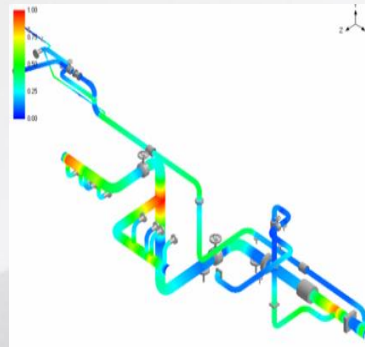
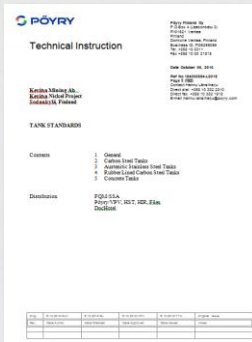

Piping material summary table for Linea Urakajaparty, detailing material specifications and quantities.

Material	Quantity	Unit	Material	Quantity	Unit
...

1. Mechanical and piping engineering: general 3/3

Drawings

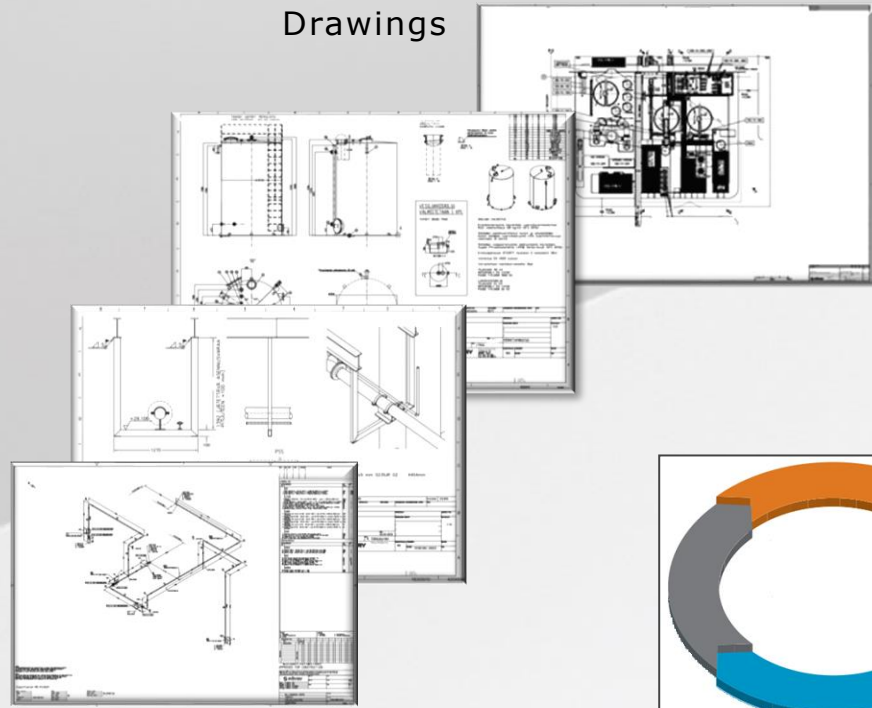

3D layout design

Communication, cooperation and inputs/outputs from/to other engineering disciplines



3D piping models, Stress calculations

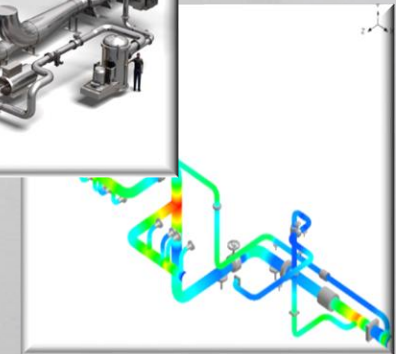

Material	Quantity	Unit	Notes
Carbon Steel	100	kg	
Stainless Steel	50	kg	
Aluminum	20	kg	

POYRY
Technical Instruction
SANKU-TEKNIKKI
SANKU-TEKNIKKI
SANKU-TEKNIKKI

Lists, material take-off's standards and specifications

2. Project workflow: engineering project phases

AFRY SMART SITE

CAPEX project phases

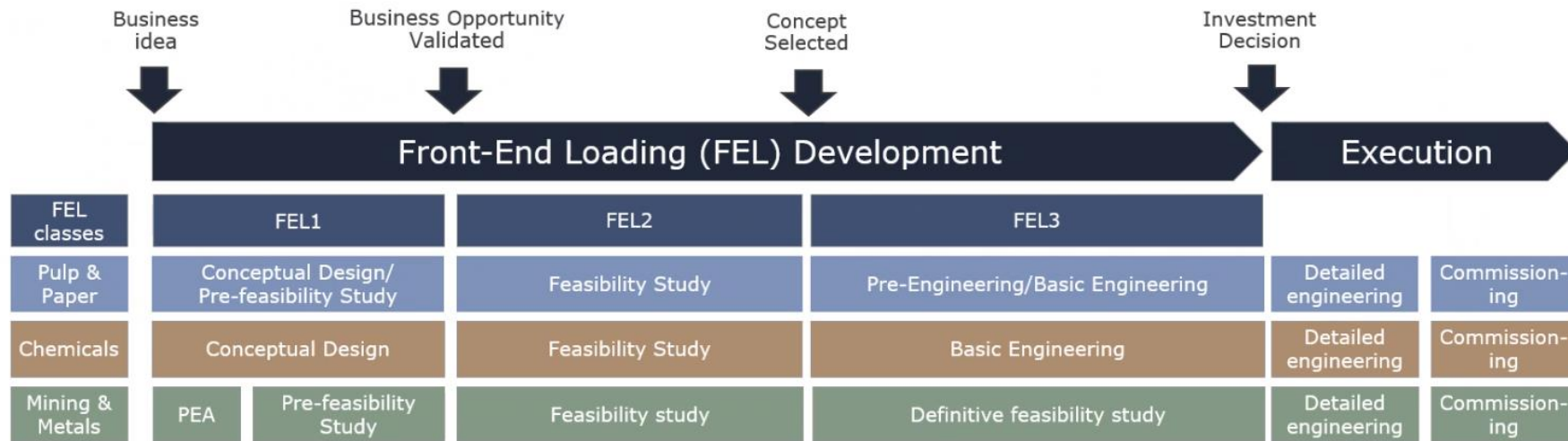

2.1 Estimated accuracy of investment cost by project phase

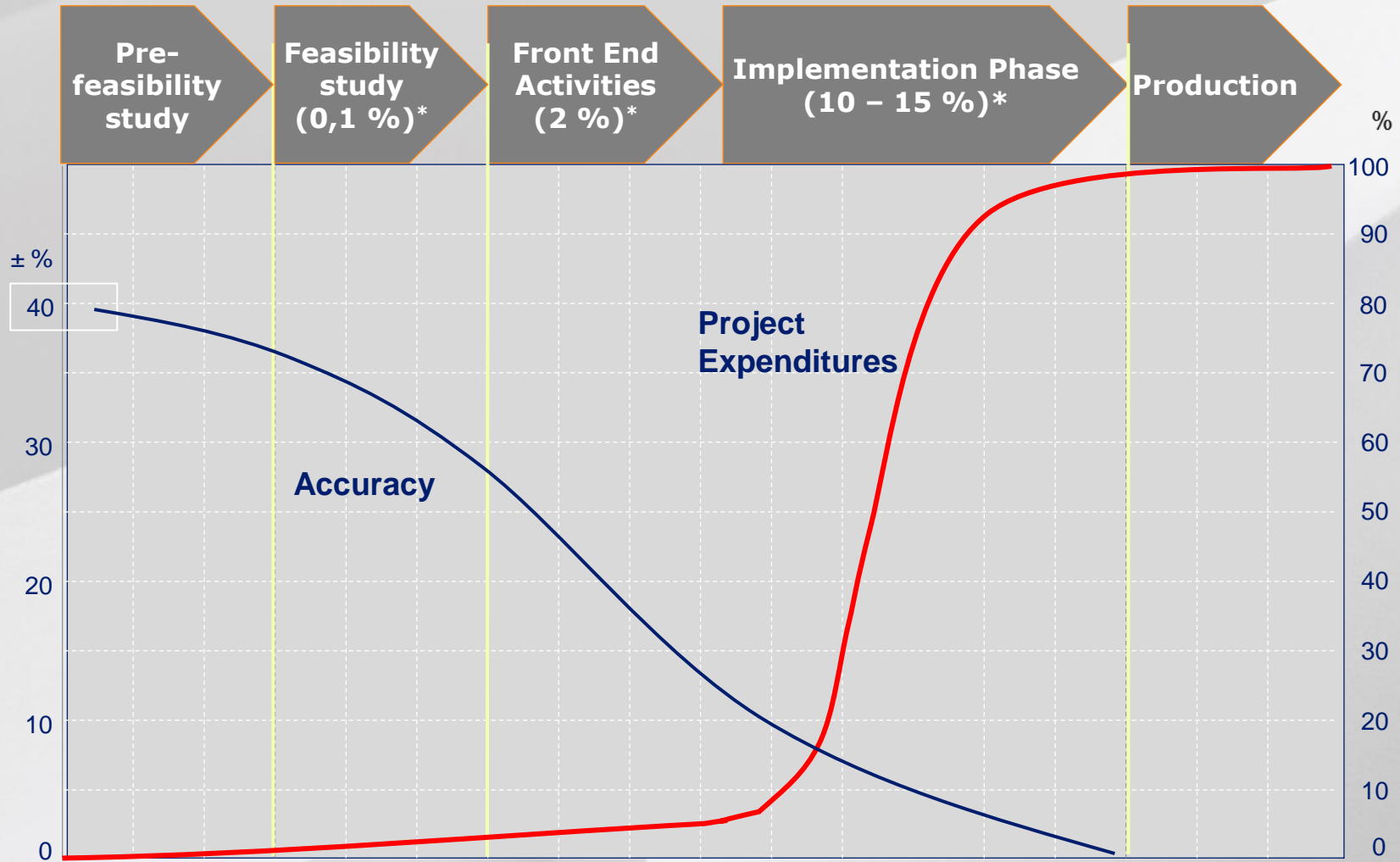

* Engineering & Project Management costs (% of the total investment)

3. Mechanical and Piping FEL1/FEL2 Phase

Engineering duration ~1-4 months

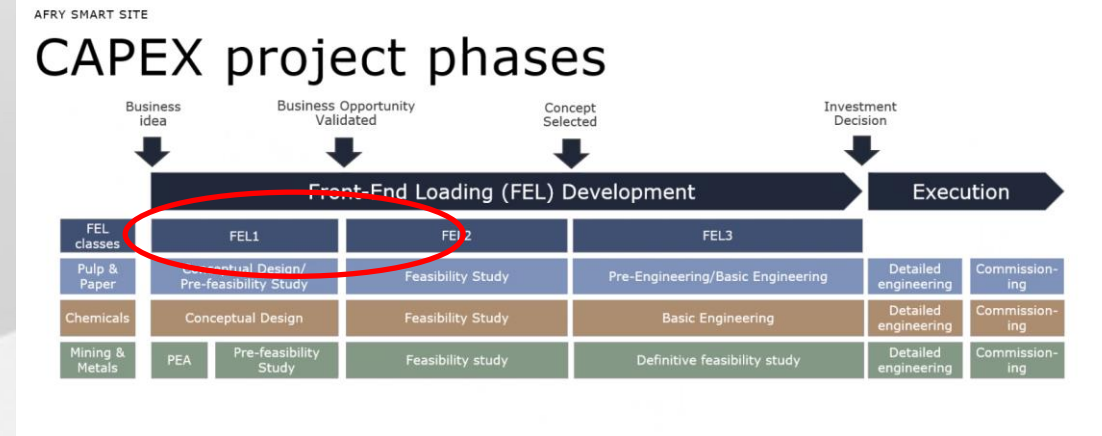

Mechanical engineering will show the space requirements regarding the mill site and the departments based on chosen process solution or several options.

- Understanding the client needs and follow scope of work. There can be several layout options to be consider.
- Understand special characteristic of the process
- Electrical engineering input: main substation, electrical rooms etc.
- Civil engineers, common understanding about main process building
- Communication and reviews internally and with the client "common understanding - way to go forward"
- Take into account local geographic, authorities' requirements, national and international standards
- Understand the process and way of thinking about the ideal material flow from layout point of view
 - Take into account effective logistics: roads, traffic, accesses, railroad, storage areas, utilities etc.
 - Knowledge about possible safety distances
- Use reference information from the previous projects
- Most often no piping engineering, only input to cost estimate based on reference data

3.1 Mechanical and Piping FEL1/FEL2 Phase deliverables

Mechanical deliverables e.g.

- Mill site layout
- Department layouts
- Input to cost estimate
- Input to report
 - Description of the layout and main reasons and definitions for the process area order.

Piping deliverables e.g.

- Piping material (pipes, components, secondary steels, insulation etc.)
- Installation cost estimation
 - Estimated/measured from the layout using preliminary process flow diagrams and/or get
 - Reference quantities reference project data bank
 - by knowing pipe meter quantities or tons it is possible to estimate material and installation costs
- Input to report: piping description

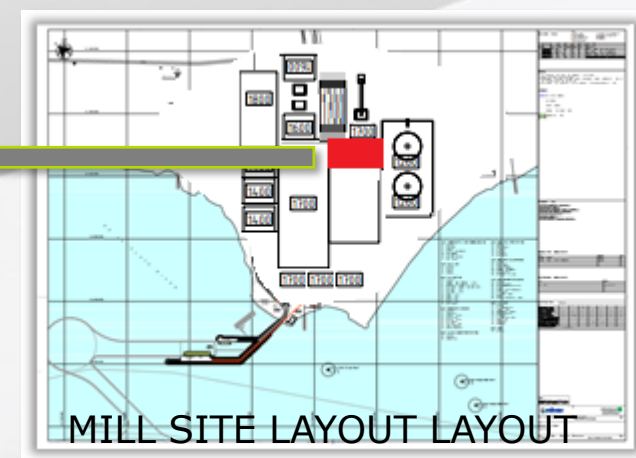
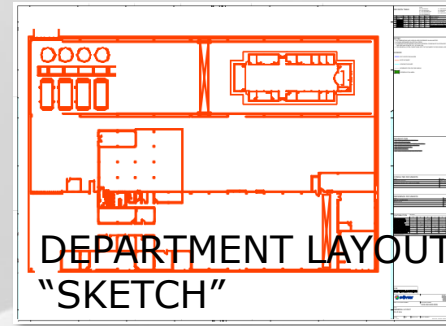

4. Mechanical and Piping FEL2/FEL3 Phase

Engineering duration ~3-12 months

- More engineering is done information available at this phase vs. FEL1/FEL2

Main tasks: Mechanical

- Investigate and understand earlier phase material
- Participate to main equipment supplier meetings and update information to the layout
 - Budget offers and equipment supplier preliminary layouts often available
- Process input: what has changed since previous engineering phase, internal communication
- Electrical engineering: more detail available: main substation, electrical and control rooms, cable trays, transformers etc.
- Communicate and review internally and with the client "to maintain same understanding"
- Inputs from main equipment suppliers
- Cooperation with civil engineering to able to define exact process building volume/ floor levels/dimensions/loads
- Make the final equipment layout modifications to the layout 's and then freeze idea of the main department and mill site layout

CAPEX project phases

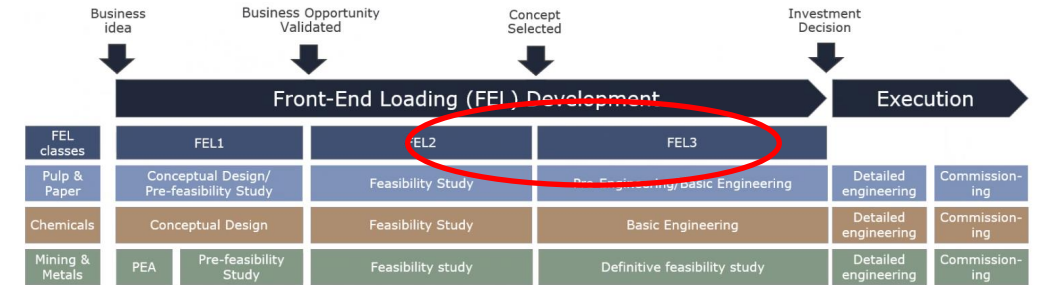

Main tasks: Piping engineering

Communicate with:

- layout engineers to find suitable pipe routes
- process engineers; main pipe routes
- equipment supplier; battery limits, nozzle orientations etc.
- stress calculation experts needed if there is already need for the preliminary pipeline stress calculation
- Preliminary 3D pipe routing is done

4.1 Mechanical and Piping FEL2/FEL3 Phase deliverables

Mechanical deliverables e.g.

- Mill site layout (updated)
- Department layouts (new)
- Input to cost estimate and report (update)
- Steel structure layout including pipe bridges
- Dismantling layout where applicable
- Preliminary load lists/drawings
- Enquiry drawings for tanks and towers
- Technical instructions and standards

Piping deliverables e.g.

- Input to cost estimate and report regarding piping
- Material take off (MTO) from the 3D piping model
- Underground pipes, drains and sewer system routing drawings
- Piping drawings
- Pipe bridge layout
- piping specifications and standards

MILL SITE LAYOUT

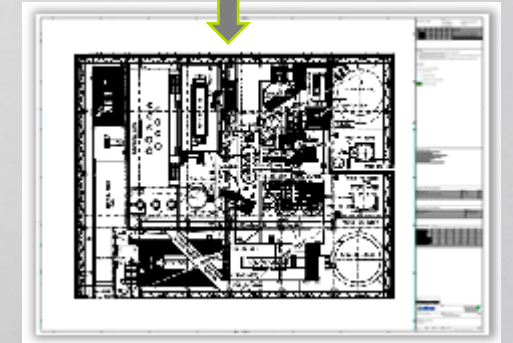

DEPARTMENT LAYOUTS

5. Example drawings before detail engineering has started

Preliminary layout drawing

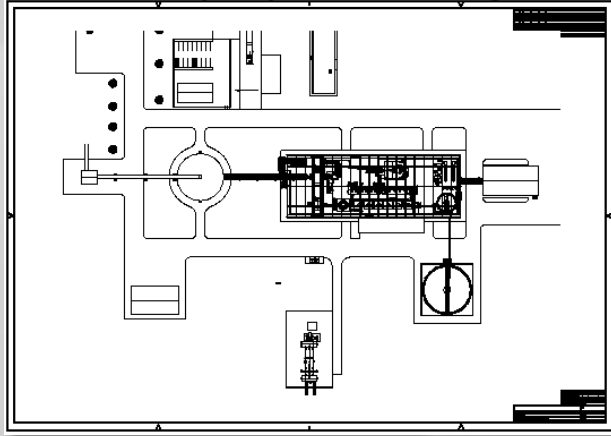

Layout 3D model

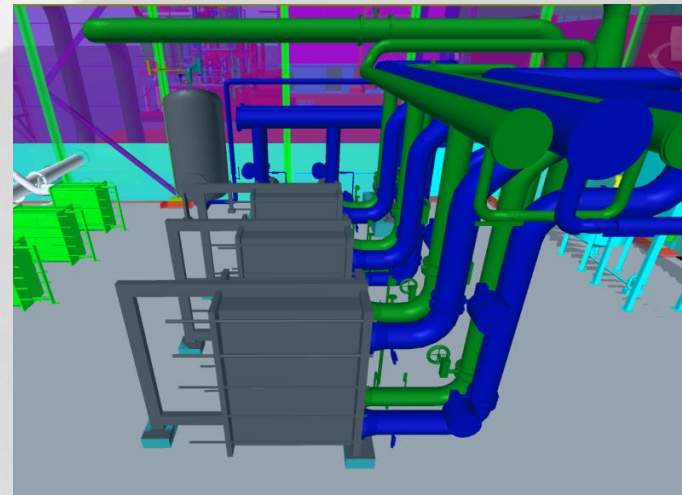
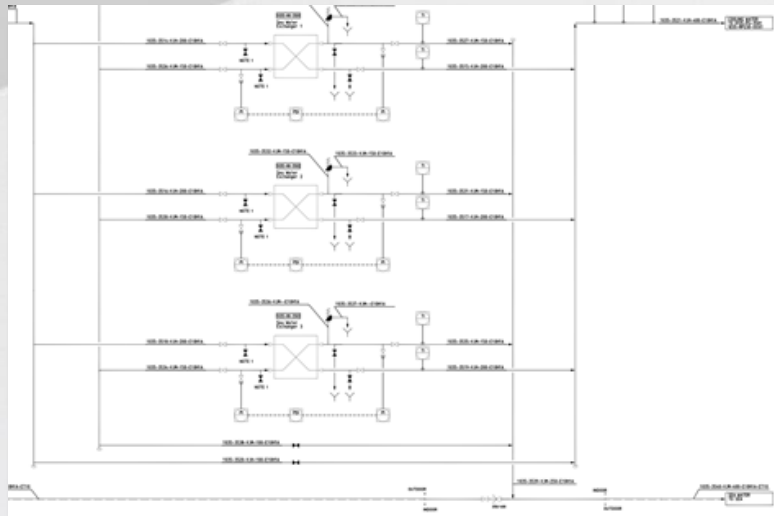

Process PI-diagram

3D Piping design according to PI-diagram

5.1 Example material take-off's and cost estimation before detail engineering has started

Piping cost estimation

Compa	Material	dn1	dn2	dn3	Detail_text	SumOfQuallit Standard	Dimensional	Material_Unit	Material_Price	Installation_Un	Installation_Pri	Total_Price
1010	1.4432	1200	0		Pipe 1220x6.3 - SFS-EN 10217-7	4,40 SFS-EN 10217-7	1220x6.3	1 669,98	7 352,27	278,52	1 226,21	8 578,48
1010	1.4432	800	0		Pipe 813x6.3 - SFS-EN 10217-7	24,63 SFS-EN 10217-7	813x6.3	951,41	23 429,77	198,00	4 876,03	28 305,80
1010	1.4432	600	0		Pipe 610x4 - SFS-EN 10217-7	0,20 SFS-EN 10217-7	610x4	2 802,00	560,40	129,36	25,87	586,27
1010	1.4432	400	0		Pipe 406.4x3.2 - SFS-EN 10217-7	0,63 SFS-EN 10217-7	406.4x3.2	1 843,09	1 160,95	84,48	53,21	1 214,17
1010	1.4432	350	0		Pipe 355.6x2.6 - SFS-EN 10217-7	1,43 SFS-EN 10217-7	355.6x2.6	720,30	1 027,87	71,28	101,72	1 129,58
1010	1.4432	300	0		Pipe 323.9x2.6 - SFS-EN 10217-7	96,14 SFS-EN 10217-7	323.9x2.6	139,50	13 412,10	60,72	5 837,87	19 249,96
1010	1.4432	150	0		Pipe 168.3x2 - SFS-EN 10217-7	9,36 SFS-EN 10217-7	168.3x2	50,05	468,29	34,32	321,10	789,40
1010	1.4432	100	0		Pipe 114.3x2 - SFS-EN 10217-7	99,36 SFS-EN 10217-7	114.3x2	33,44	3 322,96	27,72	2 754,23	6 077,18
1010	1.4432	80	0		Pipe 88.9x2 - SFS-EN 10217-7	239,27 SFS-EN 10217-7	88.9x2	26,08	6 239,10	23,76	5 684,96	11 924,07
1010	1.4432	50	0		Pipe 60.3x2 - SFS-EN 10217-7	209,15 SFS-EN 10217-7	60.3x2	19,32	4 040,74	22,44	4 693,28	8 734,02
1010	1.4432	40	0		Pipe 48.3x2 - SFS-EN 10217-7	1,65 SFS-EN 10217-7	48.3x2	15,53	25,57	21,12	34,78	60,35
1010	1.4432	32	0		Pipe 42.4 X 2 - SFS-EN 10217-7	39,90 SFS-EN 10217-7	42.4x2	13,78	549,66	18,48	737,35	1 287,01
1010	1.4432	25	0		Pipe 33.7x1.6 - SFS-EN 10217-7	46,13 SFS-EN 10217-7	33.7x1.6	9,19	424,05	18,48	852,53	1 276,58
1010	1.4432	20	0		Pipe 26.9x1.6 - SFS-EN 10217-7	1,34 SFS-EN 10217-7	26.9x1.6	8,06	10,77	18,48	24,68	35,45
1010	1.4432	15	0		Pipe 21.3x1.6 - SFS-EN 10217-7	21,55 SFS-EN 10217-7	21.3x1.6	6,55	141,19	18,48	398,24	539,43
1110	1.4432	1200	90		Elbow 1220x8 - SFS-EN 10253-4 -type A - 3D - 90	2,00 SFS-EN 10253-4 -type A - 3D	1220x8	13 080,00	26 160,00	2 225,52	4 451,04	30 611,04
1110	1.4432	1200	5		Elbow 1220x8 - SFS-EN 10253-4 -type A - 3D - 90	1,00 SFS-EN 10253-4 -type A - 3D	1220x8	13 080,00	13 080,00	2 225,52	2 225,52	15 305,52
1110	1.4432	800	90		Elbow 813x8 - SFS-EN 10253-4 -type A - 3D - 90	7,00 SFS-EN 10253-4 -type A - 3D	813x8	5 193,89	36 357,22	1 511,40	10 579,80	46 937,02
1110	1.4432	400	60		Elbow 406.4x3.2 - SFS-EN 10253-4 -type A - 3D - 90	2,00 SFS-EN 10253-4 -type A - 3D	406.4x3.2	431,59	863,18	566,28	1 132,56	1 995,74
1110	1.4432	300	90		Elbow 323.9x2.6 - SFS-EN 10253-4 -type A - 3D - 90	86,00 SFS-EN 10253-4 -type A - 3D	323.9x2.6	252,04	21 675,10	373,56	32 126,16	53 801,26
1110	1.4432	150	90		Elbow 168.3x2 - SFS-EN 10253-4 -type A - 3D - 90	8,00 SFS-EN 10253-4 -type A - 3D	168.3x2	33,58	268,61	220,44	1 763,52	2 032,13
1110	1.4432	150	30		Elbow 168.3x2 - SFS-EN 10253-4 -type A - 3D - 90	1,00 SFS-EN 10253-4 -type A - 3D	168.3x2	33,58	33,58	220,44	220,44	254,02
1110	1.4432	100	90		Elbow 114.3x2 - SFS-EN 10253-4 -type A - 3D - 90	68,00 SFS-EN 10253-4 -type A - 3D	114.3x2	13,54	920,45	158,40	10 771,20	11 691,65
1110	1.4432	100	30		Elbow 114.3x2 - SFS-EN 10253-4 -type A - 3D - 90	1,00 SFS-EN 10253-4 -type A - 3D	114.3x2	13,54	13,54	158,40	158,40	171,94
1110	1.4432	80	90		Elbow 88.9x2 - SFS-EN 10253-4 -type A - 3D - 90	77,00 SFS-EN 10253-4 -type A - 3D	88.9x2	9,48	729,96	126,72	9 757,44	10 487,40

Mechanical equipment costs

Code	Specification	Currency	Quantity	Unit	Unit price in currency	Unit price in EUR	Total	Freight	Installation in currency	Installation in EUR	TOTAL
3					-	-	-				-
3					-	-	-				-
4	Mechanical Equipment										
4	Water Exchanger	eur	3		64 515	64 515	193 545	5 806	19 355	19 355	218 706
4	Cooling Water Pump	eur	3		20 000	20 000	60 000	1 800	6 000	6 000	67 800
4	Expansion vessel	eur	1		10 000	10 000	10 000	300	1 000	1 000	11 300
4	CiP Tank	eur	1		2 000	2 000	2 000	60	300	300	2 360
4	CiP Pump	eur	1		3 000	3 000	3 000	90	450	450	3 540
4	Condensate removal pot	eur	1		3 500	3 500	3 500	105	525	525	4 130
4	LNG Evaporator	eur	1		450 000	450 000	450 000	13 500	22 500	22 500	486 000
4	LNG storage tank	eur	1		145 000	145 000	145 000	4 350	10 150	10 150	159 500
4	District heating exchanger	eur	1		14 000	14 000	14 000	420	1 400	1 400	15 820
4	Steam generator	eur	1		566 000	566 000	566 000		28 300	28 300	594 300
4	1...4 Air compressor	eur	4		26 800	26 800	107 200		10 720	10 720	117 920
4	Instrument air dryer	eur	1		46 000	46 000	46 000		4 600	4 600	50 600
4	Buffer tank	eur	1		11 400	11 400	11 400		1 140	1 140	12 540

6. Execution/Detail Engineering Phase

Engineering duration ~6-24 months

6.1 Mechanical

Target:

- From the start of detail engineering finalize the basic engineering solutions without any remarkable changes.
- Work is more or less to execute the detail phase with the detail information

Generally mechanical and piping has huge amount of tasks from the beginning of the project.

Communication needed between all project parties

- Lack of missing information can be very critical
- Share your initial information on time
- Communication with client, architects, civil, EIA, process, procurement etc.
- Organize layout and piping reviews regularly
- Follow time schedule and document delivery schedule
- Check the drawings and documents to achieve enough high quality
- Prepare beforehand time to support the procurement activities and other disciplines -> understand the project time schedule
- Follow your own discipline progress
- Make sure that 3D models received on time from the other disciplines or 3rd parties (civil, EIA, to able to maintain up to date layout)

CAPEX project phases

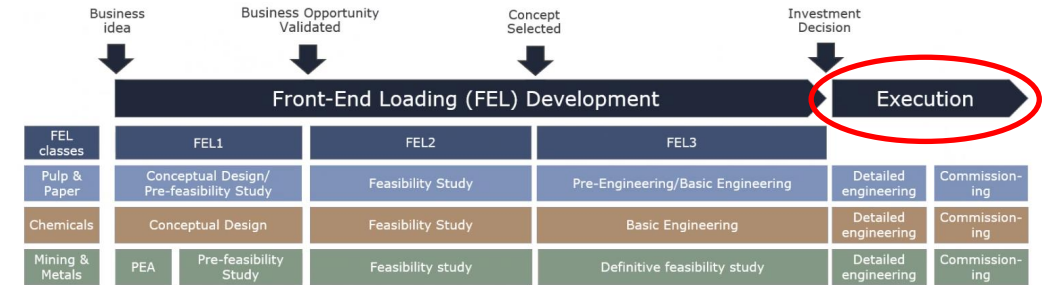

6.2 Piping Engineering

Tasks:

- Design all the pipes that are presented in the PID 's and scope of work
- Piping 3D library is up to date (supplier components and valves are available to piping design)
- Design of pipe- and supports (outline drawings or manufactory drawings)
- Piping calculations are done before finalizing drawings
- Collect pipe related instrument and components installation information from electrical and instrumentation disciplines able add them to 3D model correctly
- No more cost estimations. Enquiries to the contractors

Example key figures: Engineering hours

- If total engineering cost is ~10% of the total investment then:
 - mechanical and piping is 1/3 of 10% ->~3%
 - 3% is divided to: Mechanical 40%, piping 60%

Example calculation of 10000 meters of mechanical and piping engineering:

Total hours: 2h x10000h= 20000h x (cost per hour)

- 2h/m (brownfield)
- 1h/m (greenfield)

Mechanical eng. 0,4x20000h = 8000h

Piping hours: Piping eng. 0,6x20000h= 12000h

Piping capex:

-Generally: piping material and installation is 5-8% of total capex

7. Detail engineering tasks: Mechanical Engineering

	Tasks	Deliverables	Typical documents
M-Mechanical Engineering	General Mechanical Engineering	<ul style="list-style-type: none"> •Coordination between Disciplines 	<ul style="list-style-type: none"> •Coordination, memos etc. •Engineering instructions •Tank inquiry •Overhead Crane inquiry
	3D Layout Design	<ul style="list-style-type: none"> •Mill Site •Departments •Visualization Products •Routing of underground Pipes •Equipment Modeling 	<ul style="list-style-type: none"> •Mill Site Layouts •Area Layouts •Department Layouts •Equipment arrangement layouts •Mill Site Visualizations •Animations •Routing of underground pipes
	Civil Guide Design	<ul style="list-style-type: none"> •Modeling of buildings •Civil Guide Drawings 	<ul style="list-style-type: none"> •Loading drawings •Civil Guide Drawings •Insert lists •Building Model •Equipment Models
	Tank and Tower Design	<ul style="list-style-type: none"> •Tank Inquiry Drawings •Tank Outline Drawings 	<ul style="list-style-type: none"> •Tank Inquiry Drawings •Tank Outline Drawings •Workshop Drawings for tanks
	Miscellaneous Steel Structure Design	<ul style="list-style-type: none"> •Main Outline Drawings For Miscellaneous Steel Structures 	<ul style="list-style-type: none"> •Main Outline Drawings for Miscellaneous Steel Structures •Work Drawings for Steel Structures

7.1 Detail engineering tasks: Piping engineering (1/2)

	Tasks	Deliverables	Typical documents
T-Piping Engineering	General Piping Engineering	<ul style="list-style-type: none"> •Coordination between Disciplines •3D System Mgmt And Work 	<ul style="list-style-type: none"> •Coordination, memos etc. •Engineering Follow Up •Engineering Instructions •Inquiry's for pipes and installation •3D system management •3D system specifications
	Piping Engineering	<ul style="list-style-type: none"> •3D Piping model 	<ul style="list-style-type: none"> •Pipe Routing •Pipe Detailing •Piping Arrangement Drawings •Pipe detail & system drawings •Browser model •Isometric Drawings •Bill of Materials/material take off
	Piping Support Design	<ul style="list-style-type: none"> •3D Support Model 	<ul style="list-style-type: none"> •Pipe Support Standard •Pipe Support Drawings •Bill of Materials

7.2 Detail engineering Tasks: Piping engineering (2/2) Piping Specifications and Standards

	Tasks	Deliverables	Typical documents
B-Engineering Services	General Mechanical Engineering	<ul style="list-style-type: none"> •Mec. Specifications •Mechanical standards •Technical Inquiries 	<ul style="list-style-type: none"> •Technical Specifications •Tank Standards •Technical Inquiries •Bid Comparisons
	General Piping Engineering	<ul style="list-style-type: none"> •Piping Specifications •Piping Standard Files •Material Management 	<ul style="list-style-type: none"> •Piping Specifications •Piping Standard Files •Piping Material Lists and Comparison •Insulation Lists •Piping Support Lists
	Technical Calculations	<ul style="list-style-type: none"> •Stress Calculations •FEM Calculations 	<ul style="list-style-type: none"> •Stress Calculations •FEM Calculations •Piping Component Calculations •Branch Calculations •Tank Wall Calculations •Foundation Calculations •Earthquake Calculations •Wind Calculations •Pump Calculations •Flow Calculations

8. Summary

Study, pre- and basic engineering phases (FEL1 –FEL3)

- Critical for the plant success
- Less man-hours
- More possibilities to affect the outcome
- Tools: 2D, 3D and visualization

Detail Engineering phase

- Critical for the project success
- A lot of work in a short time
- Managing the information is the challenge, integration needed
- Execute according to plan
- Tools: 3D & databases

Construction phase

- Managing the changes at the site

Operations & Maintenance

- Continuous improvement
- Keeping the mill and virtual model up-to-date
- Laser scan for rebuilds

Data generated during a project

EXAMPLE

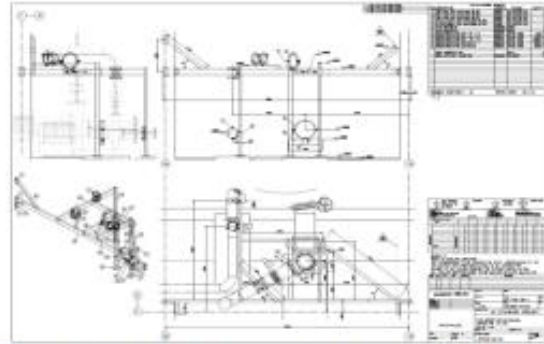

Piping support drawing

Description	Elbow
Pipeline	8704.D3
System	P90
Flowmedia	PULP, BROKE, PM
Pipeclass (PRO)	10H2A
DN	400
Dimensions	408 x 4.0, 500
Designer	12
From	8704.01 LINE
To	23TP1010 MIXING TANK
X Location	837 west of LINE 13
Y Location	3130 north of LINE C
Elevation	102500

Component data

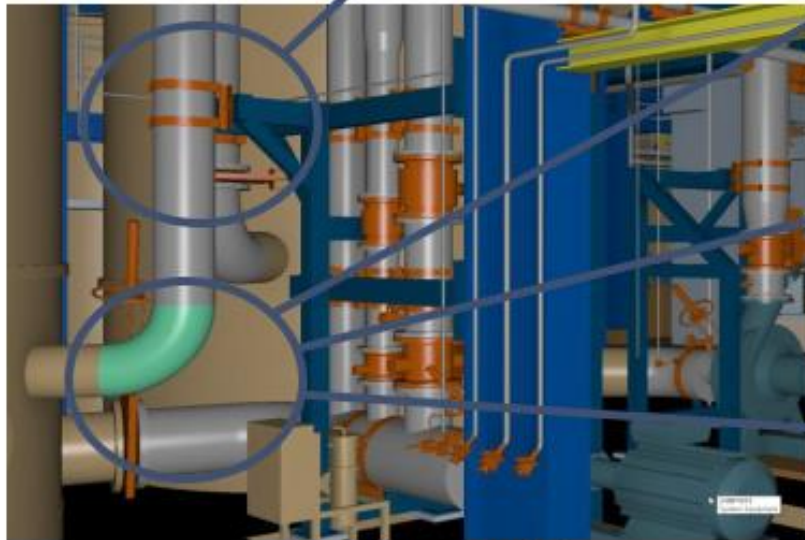

3D review model

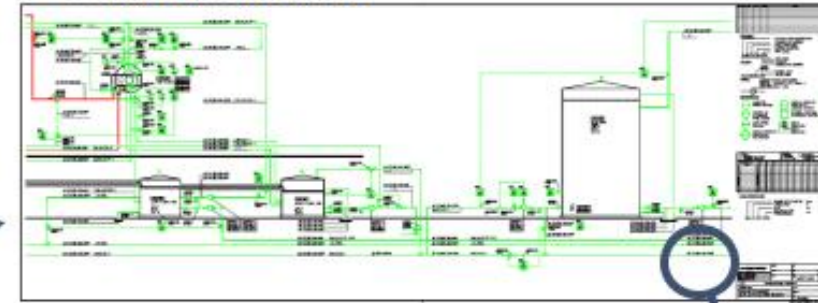

PI diagram

Hyperlink

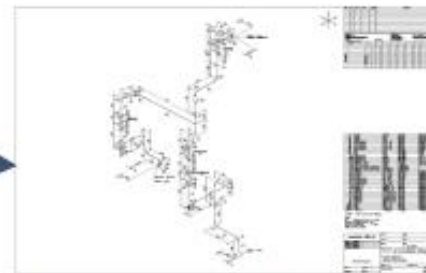

Piping Isometric drawing



Data generated during a project

EXAMPLE

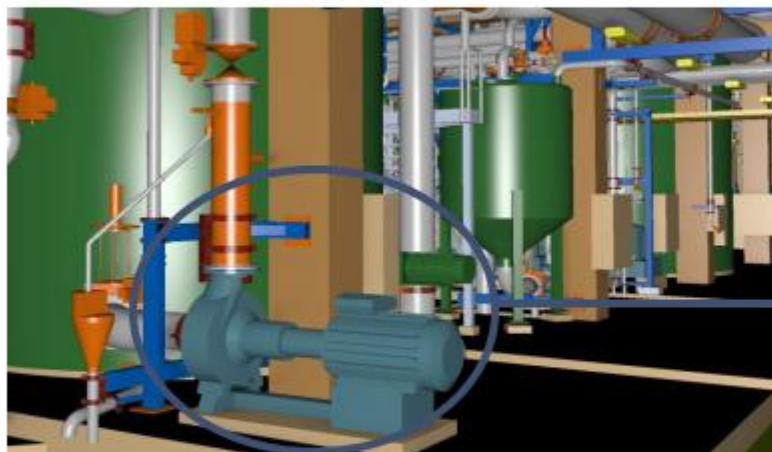

3D review model

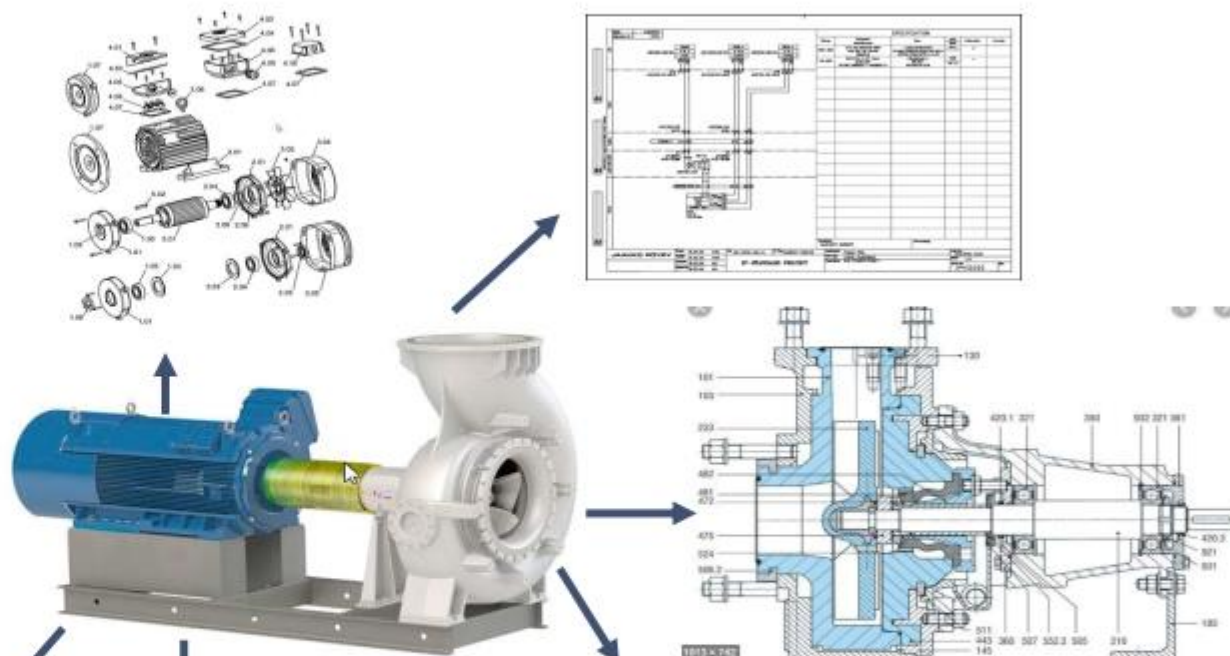

User manual

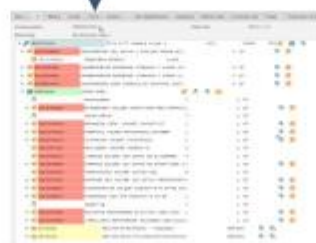

ERP

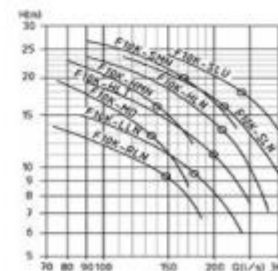

Process steps

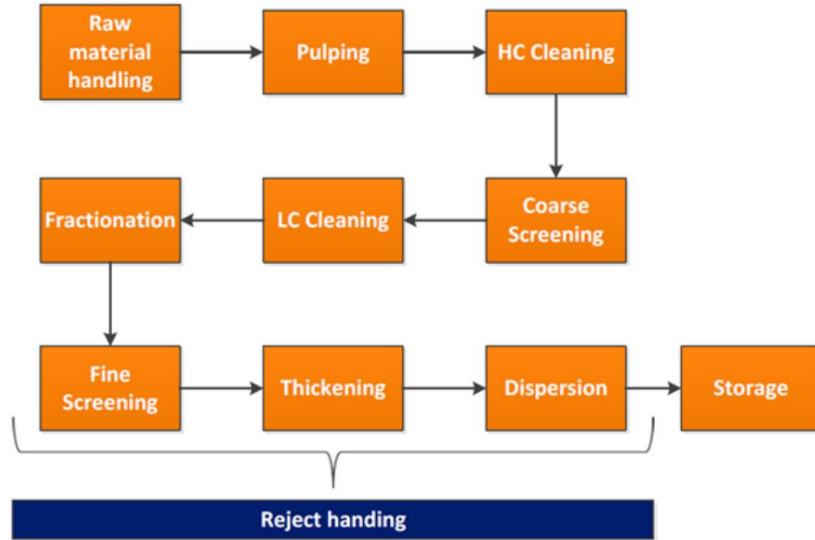

EXAMPLE: Process and layout

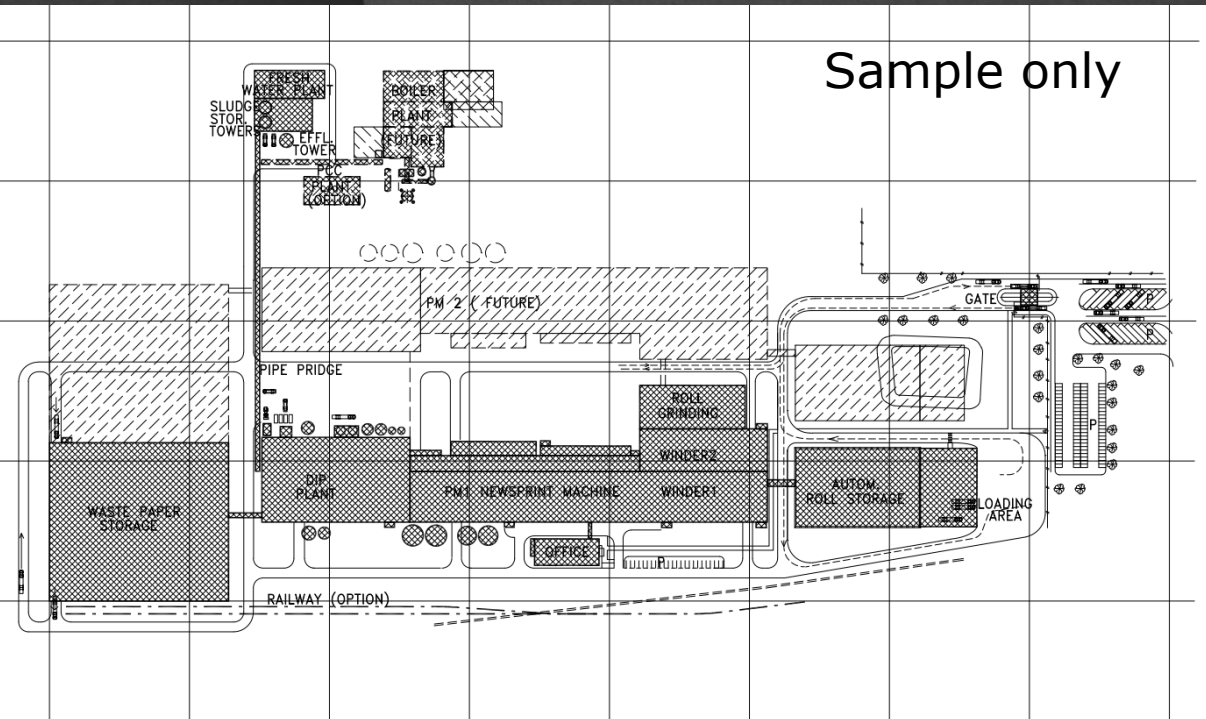

Teams Formation & Tasks Distribution Principle

- Each team shall execute following task
 - **Management**
 - assignment planning and tasks
 - project organization chart
 - implementation plan
 - manpower planning
 - risks, document handling, presentation and team leading
 - Putting the quotation together, checking everything is in order
 - **Project controls team**
 - cost data & scheduling
 - life cycle cost analysis
 - **Engineering**
 - Equipment list, process description and operating values
 - Layouts & line diagrams
 - HSE
- Team roles (examples)
 - **Project Management**
 - Project or Proposal Manager
 - Coordinator /Document Manager /Procurement Manager
 - Risk /Contract Manager
 - **Project Controls**
 - Time Scheduler
 - Cost Controller
 - **Engineering**
 - Engineering Manager
 - Health, Safety and Environment Manager

Thank You!