



Aalto University  
School of Chemical  
Engineering

# Morphology of native cellulose: the microfibril

Eero Kontturi

*Department of Bioproducts and Biosystems  
School of Chemical Engineering*

**CHEM-E2140 Cellulose-based fibres**

# Learning outcomes

After this lecture, the student will be able to:

- Describe how cellulose occurs in nature (in microfibrils)
- Possess command on basic facts about microfibrils
- Spot the gaps in knowledge of cellulose microfibrils
- Be aware of the disputes concerning microfibrils

# Outline

- (1) Facts about native cellulose microfibrils (CMFs)
  - Quick view on biosynthesis
  - Relatively undisputed facts about CMFs
  
- (2) Disputed issues about CMFs
  - Width of CMFs
  - Number of chains in a CMF
  - Twist along the CMF
  - Longitudinal disorder: fringed fibrillar model and levelling off DP
  
- (3) Bundling of CMFs

# What do we know about the cellulose microfibril?

# Cellulose microfibril in the cell wall

The cell walls of all plant fibres are reinforced by cellulose microfibrils

Wood fibre consists of a layered cell wall matrix

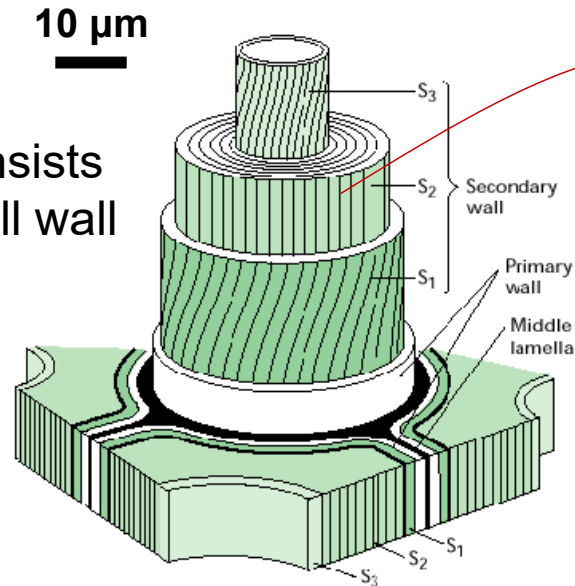

Cellulose microfibril  
Diameter: **3-20 nm**  
(In wood: 3-4 nm)

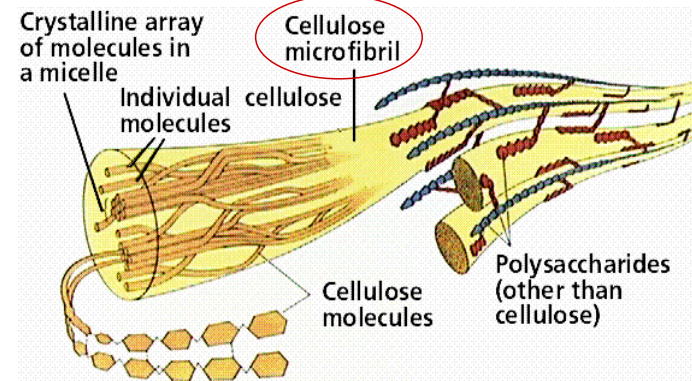

# Appearance of microfibrils

Algal microfibrils ~20 nm width

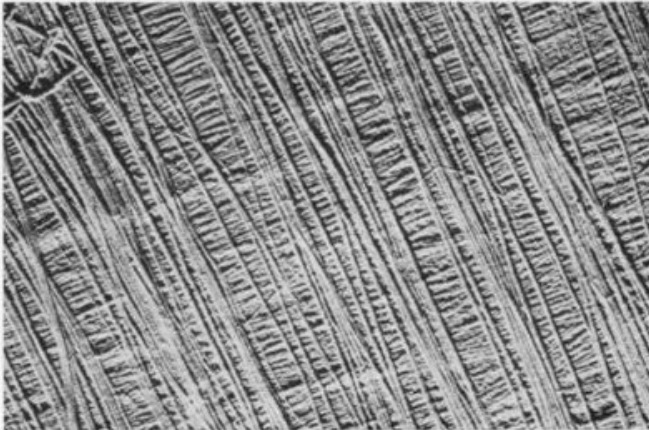

Ramie microfibrils ~6-7 nm width

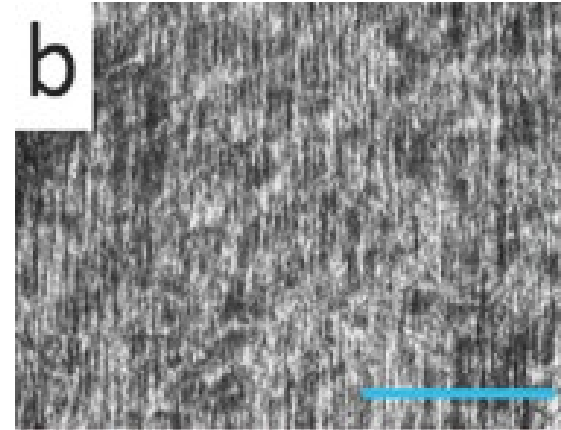

# Biosynthesis of cellulose microfibril

\*cellulose synthase subunits

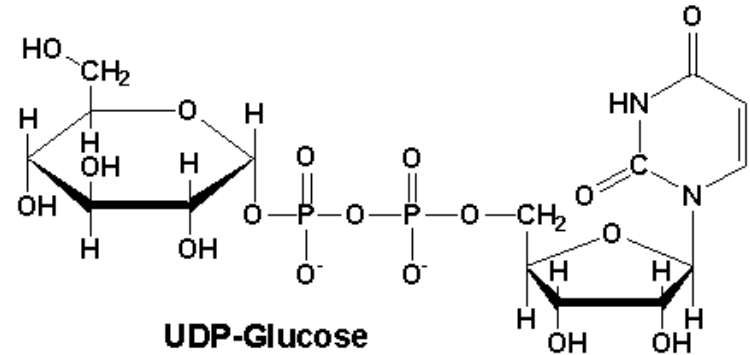
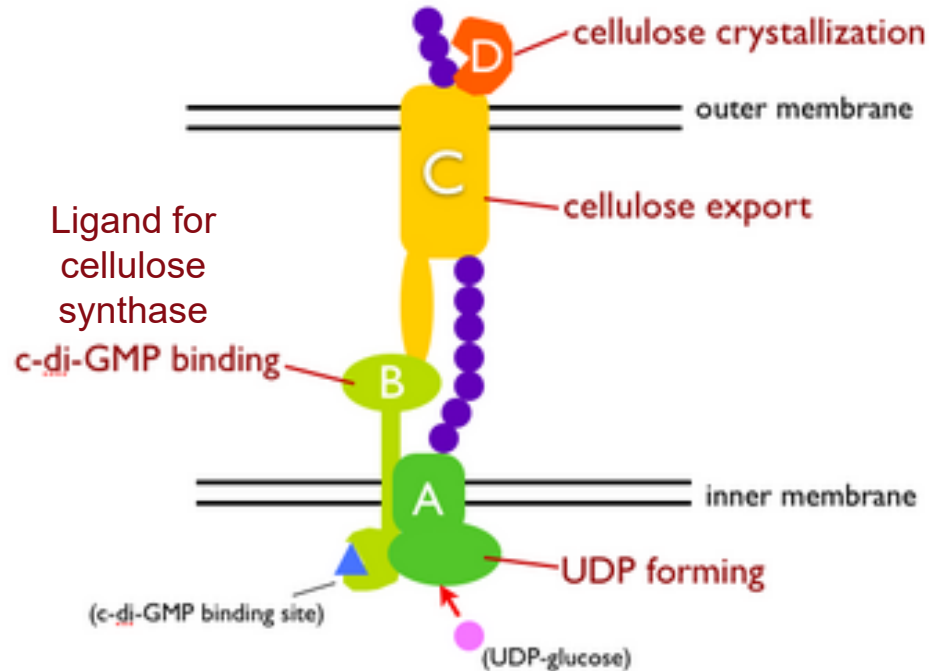

# Cellulose synthase: a rosette

- Cellulose synthase (CesA) complex is called a *rosette*
- 6 CesA units form a rosette subunit, 6 subunits form a complete rosette

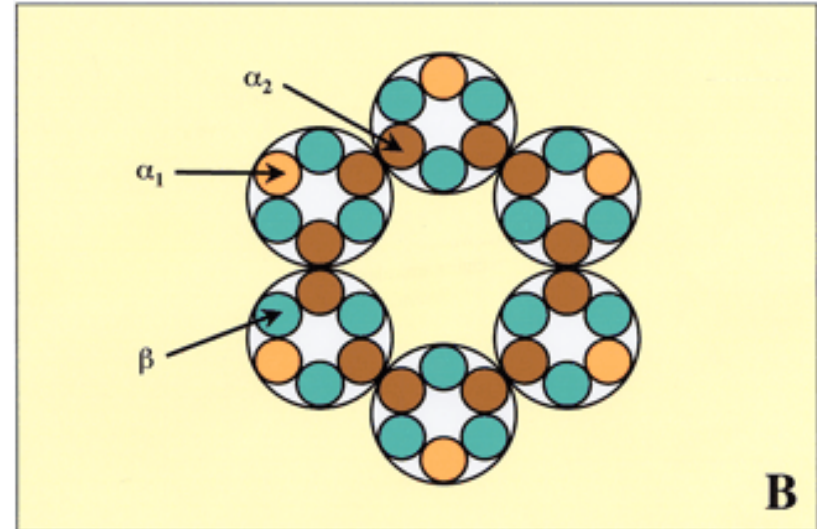
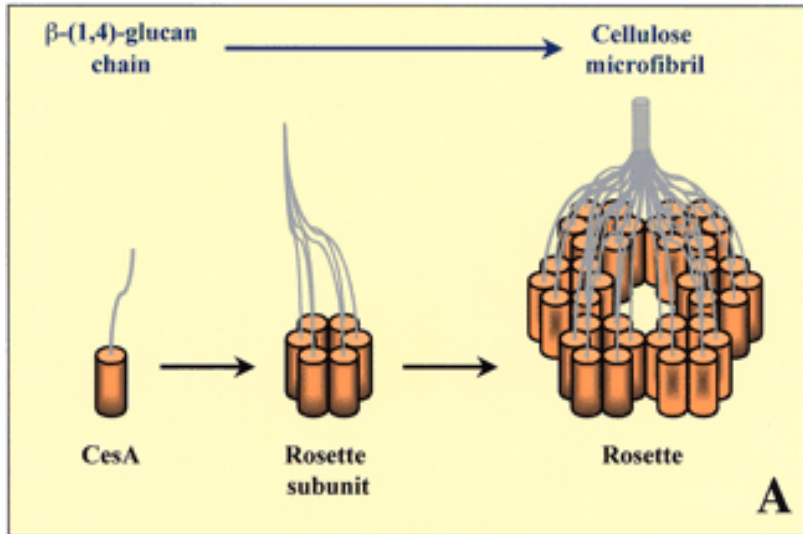

- Each CesA synthesizes one cellulose chain
- 6 $\times$ 6 rosette is held as circumstantial evidence for 6 $\times$ 6 chain model for the cellulose microfibril



# Major implication of cellulose biosynthesis

- Cellulose crystallizes as it synthesizes
- Native cellulose is *always* in the form of microfibrils
- There are no individual chains of cellulose in nature
- There is no amorphous cellulose in nature

# Relatively undisputed facts on native microfibrils

- Smallest supramolecular unit of cellulose in the plant cell wall
- Monodisperse width (nm range)
- The width depends on the botanical source
- Very long ( $\mu\text{m}$  range, owing to high DP of native cellulose)

# Disputed issues about cellulose microfibril (CMF)

# Cellulose microfibril (CMF) – major controversies

- Width of the CMF
- How many chains make up the CMF
- Twist (chirality) along the CMF
- Longitudinal disorder: the fringed-fibrillar model

# Unit cell vs. crystallite width

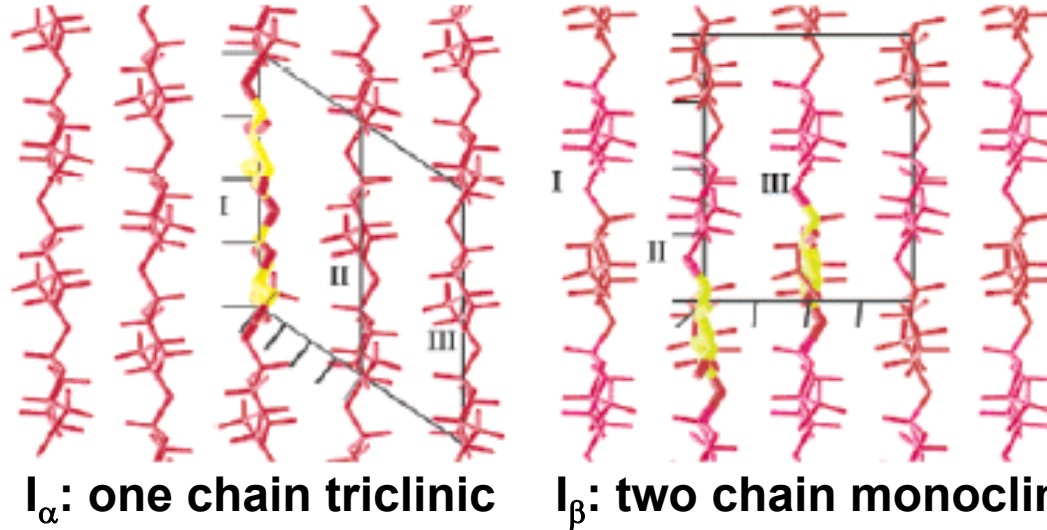

Crystallographic details in 1Å resolution (cellulose I<sub>α</sub> ja I<sub>β</sub>):

Nishiyama et al.

*J. Am. Chem. Soc.* **2002**, 124, 9074.

*J. Am. Chem. Soc.* **2003**, 125, 14300.

*In general, the unit cell of crystalline cellulose is recognized and agreed upon but the width of the crystallite and general morphology of the microfibril is still elusive*

# Terminological note

- 36 and 24 chain models refer to the smallest CMFs, such as those present in wood cells
- Often these smallest CMFs are referred to as elementary fibrils
- In many species, the CMFs are larger but they are multiples of the elementary fibrils
- Often the CMFs (or elementary fibrils) aggregate, forming larger CMF bundles

# Measured CMF widths

Source	Degree of crystallinity	Microfibril width*	Microfibril width**
Algal cellulose	>80 %	10 nm	10-35 nm
Bacterial cellulose	65-79%	5 nm	4-7 nm
Cotton linters	56-65%	5 nm	7-9 nm
Ramie	44-47%	5 nm	3-12 nm
Hemp	60%	3-5 nm	3-18 nm
Flax	56%	4-5 nm	3-18 nm
Dissolving pulp	43-56%	4-5 nm	10-30 nm

\*) Deduced from X-ray diffraction (reflection from 110 lattice plane)

\*\*\*) Deduced from transmission electron microscopy images

# Models for CMF



# Note on the models

- **These models deal with the size, shape and number of cellulose chains in the smallest cellulose microfibrils, i.e., those residing in wood**
- **CMFs residing in other plant fibres are considered multiplicates of these smallest microfibrils**

# Models for cellulose crystallite / microfibril: the 6×6 model

Figure taken from:  
Okita et al. *Biomacromolecules* **2010**, 11, 1696.

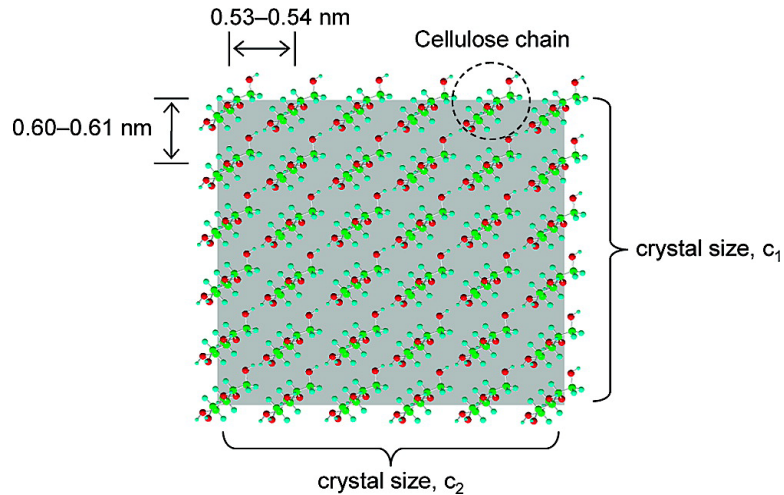

Endler and Persson *Mol. Plant.* **2011**, 4, 199  
(Review)

## The 6×6 model (rectangular)

- Most common model for CMF
- Based on circumstantial evidence on the 6×6 organisation of the rosette in biosynthesis
- Roughly fits the evidence (XRD and microscopy data)
- Much of the molecular modelling of CMFs is performed with this model

# Alternative 6×6 model

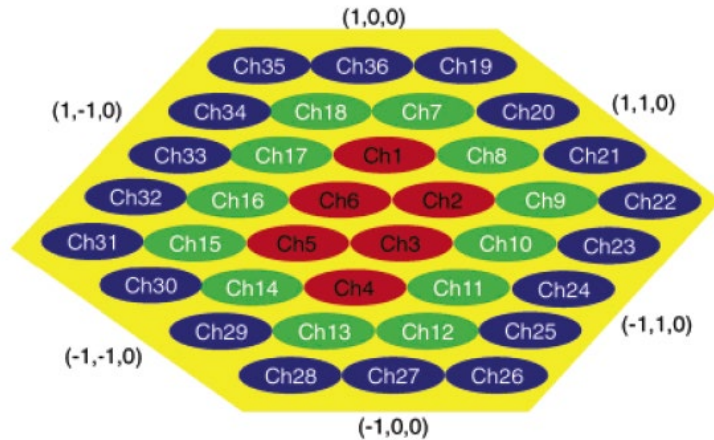

## The 6×6 model (irregular hexagon)

- Based entirely on atomic force microscopy (AFM) data
- Widely used despite the fairly weak experimental evidence
- Used in some molecular modellings of CMFs

Ding and Himmel *J. Agric. Food Chem.* **2006**, *54*, 597

# 24 chain model

Two possibilities: rectangle or “diamond” model

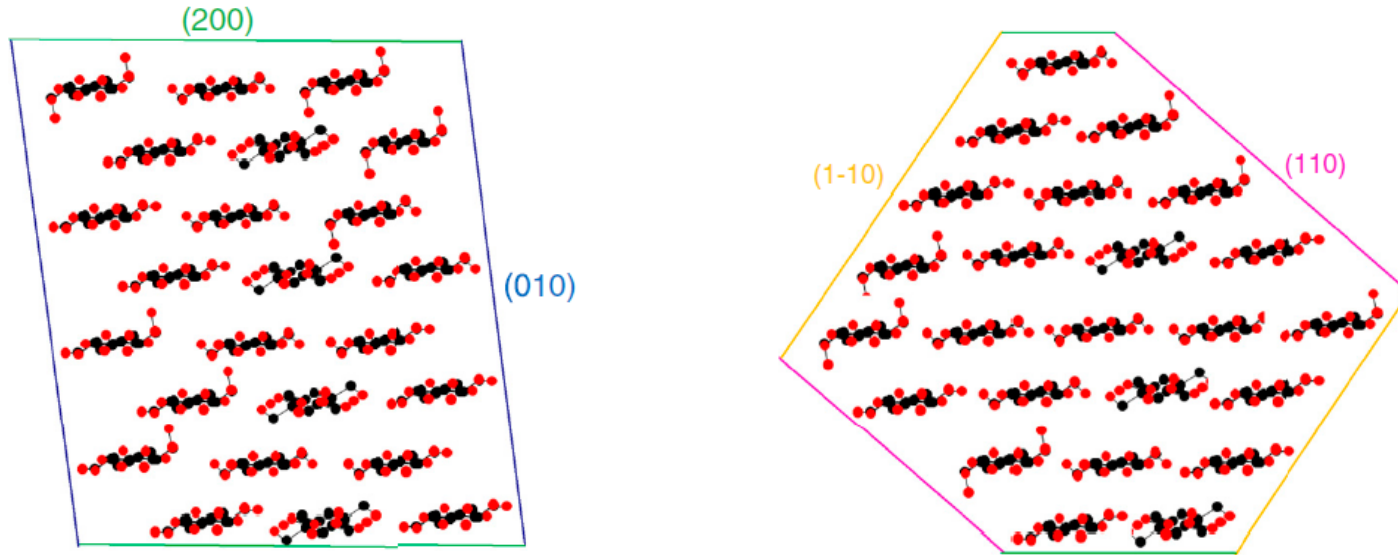

Fernandes et al. *PNAS* 2011, 108, E1195

# 24 chain model

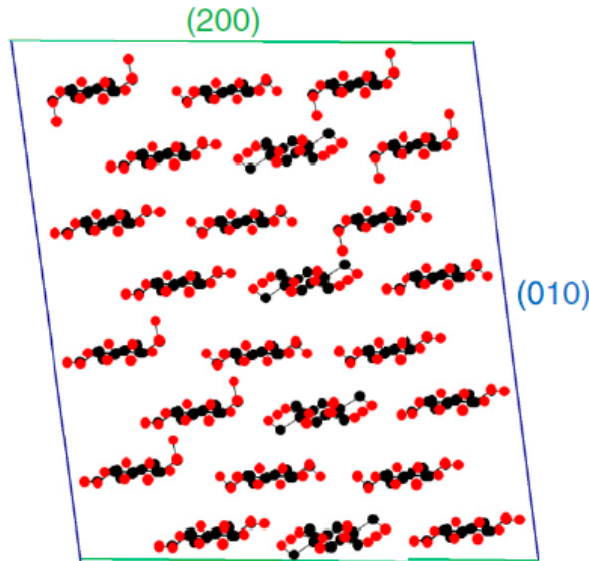

## 24 chain model

- Based on several techniques: FTIR, NMR, and diffraction
- A credible alternative
- A disputed model but has the most substantial experimental data of all CMF models
- Suggests that only 4 of the 6 rosettes are simultaneously active during biosynthesis

Fernandes et al. *PNAS* **2011**, *108*, E1195

# 18-24 chain model

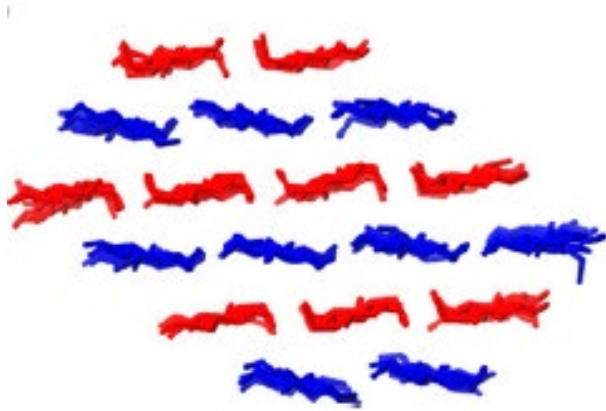

## 18-24 chain model

- Based on molecular dynamics simulations in aqueous environment
- Comparison with previously published experimental data suggests that a 36 chain model is highly unlikely
- Proposes that CMF is made of either 18 or 24 chains
- Endorsed by the researchers who originally came up with the 24 chain model

Oehme et al. *Plant Physiol.* **2015**, 168, 3

# 18-chain models

234432 model

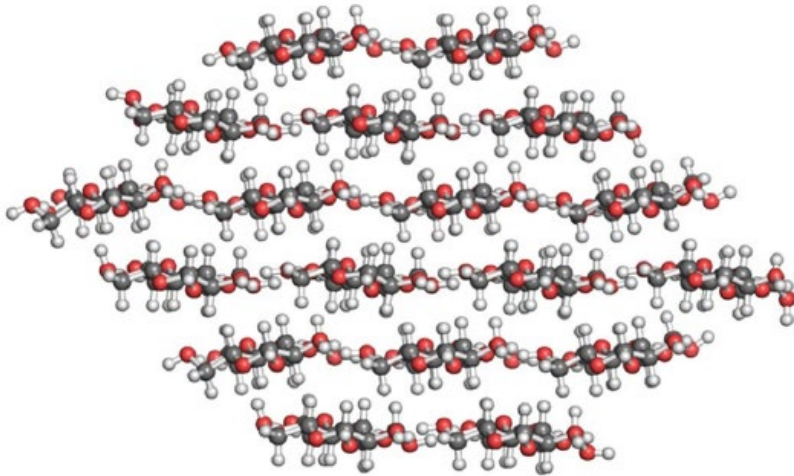

34443 model

Hydrophobic plane (C-H groups)

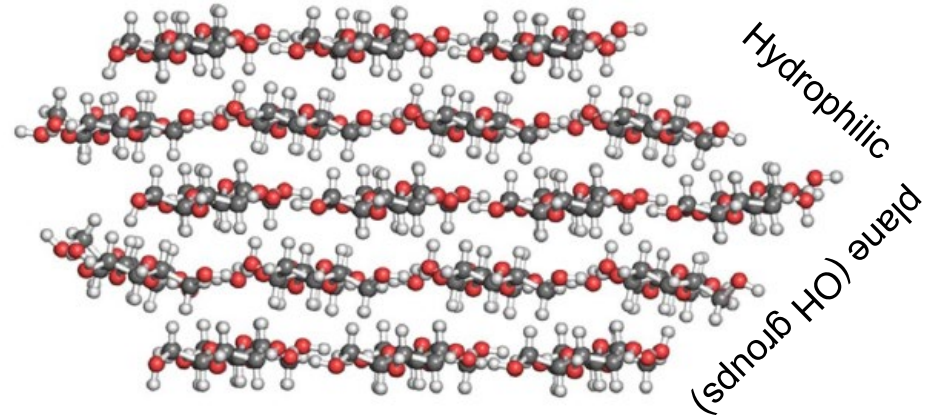

Deemed as the most probably option  
according computer simulations

# Twist along CMF



# Simulations suggest twist



Isolated cellulose chains twist in simulations

Conley et al.  
*Carbohydr. Polym.* **2016**, 135, 285.

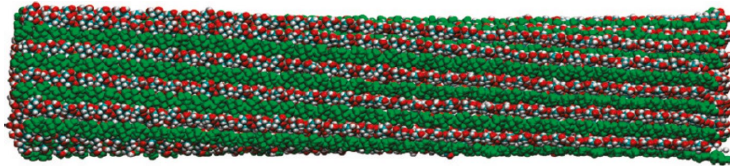

Paavilainen et al.  
*J. Phys. Chem. B* **2011**, 115, 3747.

- Computational models of very small cellulose crystals are twisting
- The periodicity of the twist is longer than with individual chains
- The twist is right-handed

# CMF twist: experimental evidence

Electron tomography on a cellulose nanocrystal

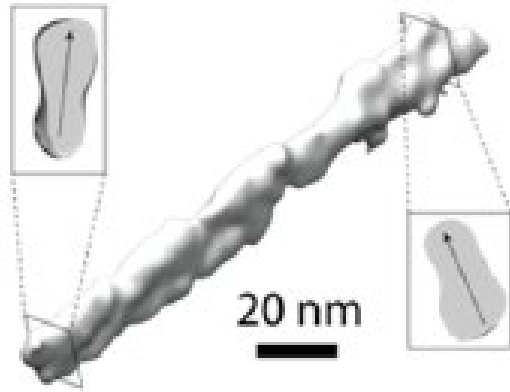

- Experimental evidence on CMF twist is not unambiguous
- Many images abound in literature but quantitative data is missing

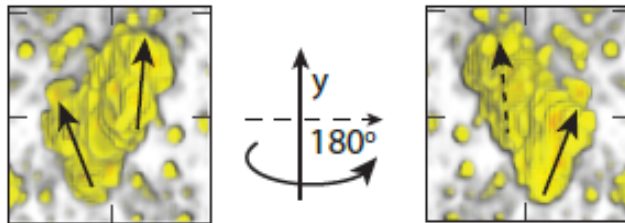

# CMF twist: experimental evidence

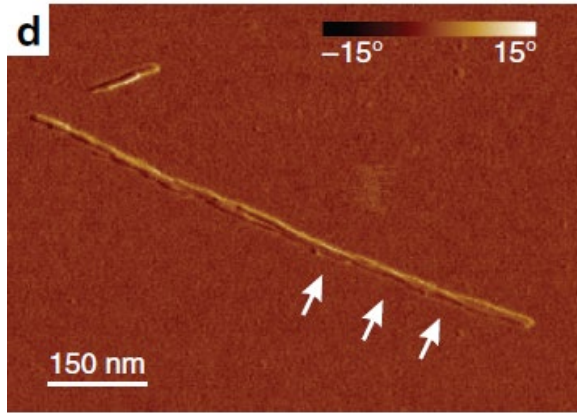

- Visualization on CMF twist is not unambiguous
- Many images abound in literature but quantitative data is missing

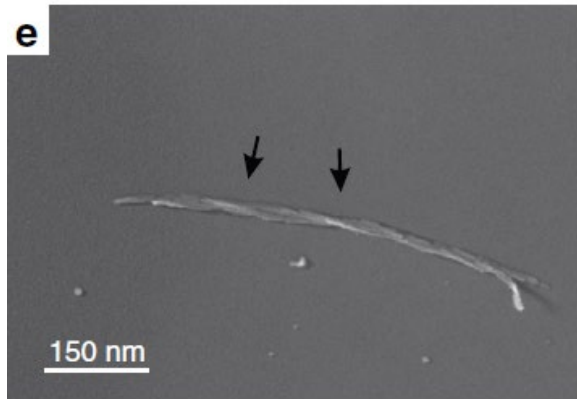

# Experimental and simulation evidence

- Time-dependent density functional theory calculations combined with circular dichroism on CNCs with adsorbed Congo red dye molecules
- Combined simulations and experimental evidence suggests a right-handed twist of 800 nm period in wood cellulose nanocrystals
- Long period is probably the reason why the twist is so difficult to visualize from CNCs

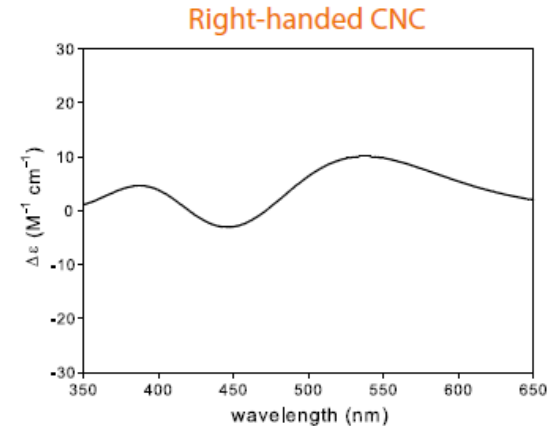
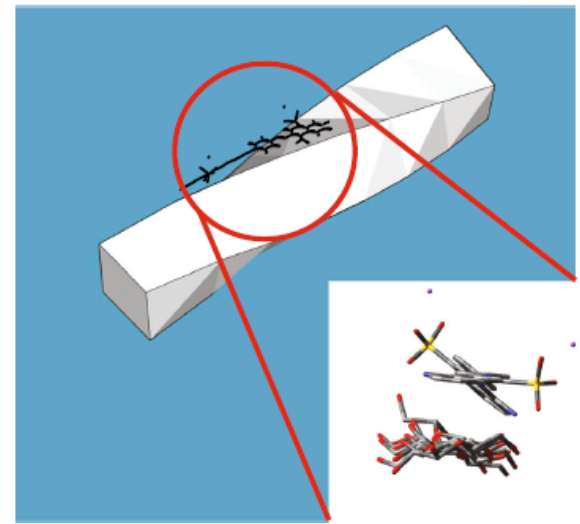

# Proposed alteration of CMF twist

- Some accounts suggest that the twist is altered and “localized” upon drying

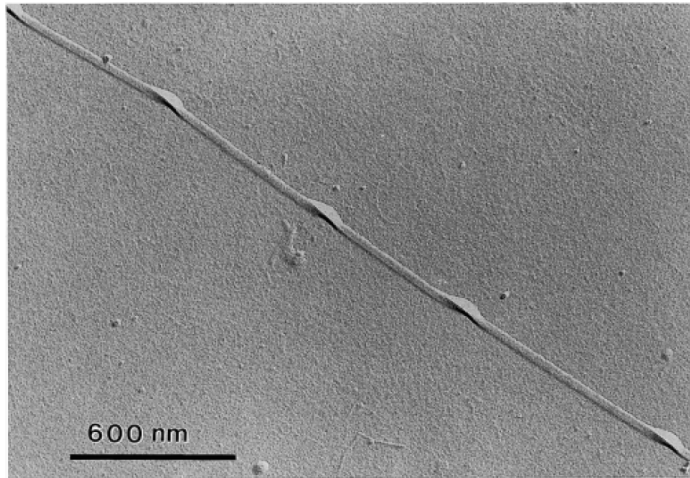

CMFs of *M. denticulata* alga  
after drying

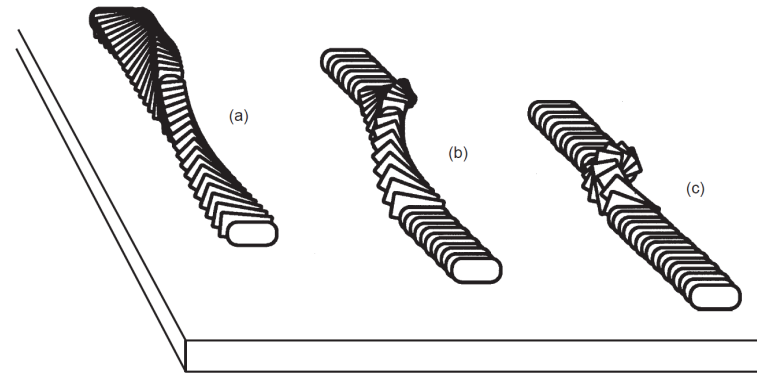

Suggestion on what happens to a  
pristine CMF (a) upon drying (b)  
and in a totally dried state (c)

# Implication of the CMF twist

Cellulose nanocrystals spontaneously forms a liquid crystal phase in solution

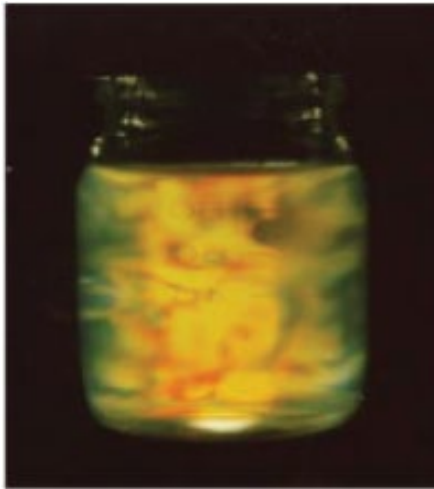

Photograph of liquid crystal suspension of cellulose nanocrystals

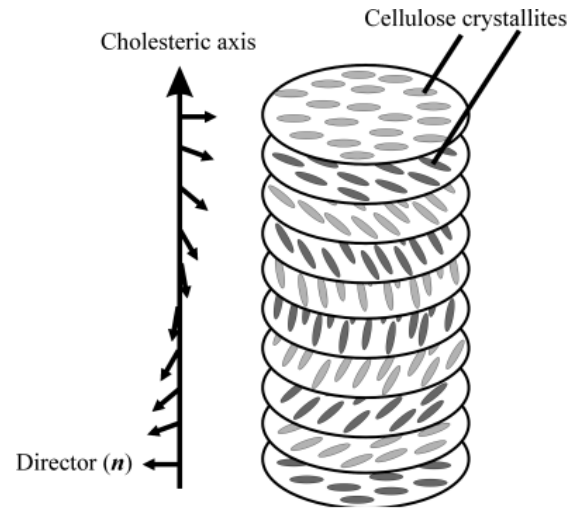

Chiral nematic phase formed by cellulose crystallites

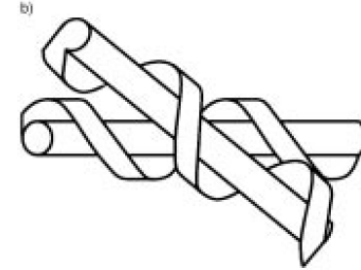

Tight packing by the chiral interaction of screwlike rods

# Fringed fibrillar model

# Longitudinal disorder: semi-crystallinity

Crystallographic data presents evidence that cellulose within microfibrils is not totally crystalline.

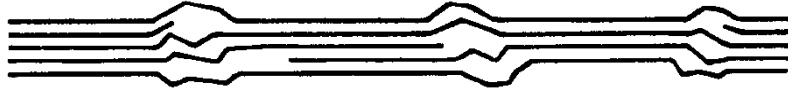

**Proposition:**  
cellulose runs through alternating crystalline and “ amorphous” regions.

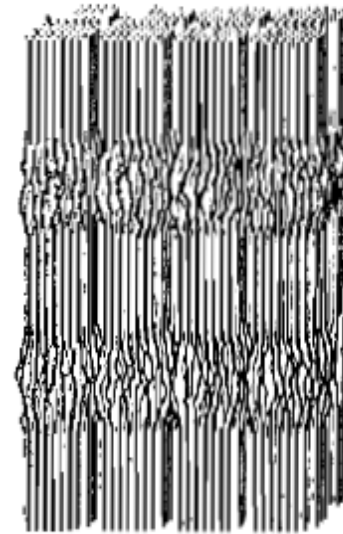



# Fringed-fibrillar model of CMFs

- According to various models, **disordered** cellulose segments coexists with crystalline cellulose in native cellulose microfibrils.

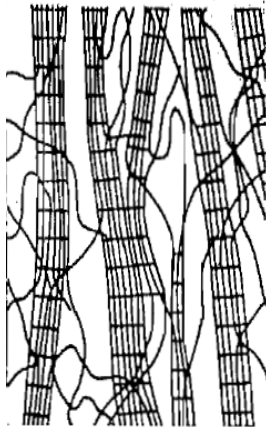

Hearle 1958

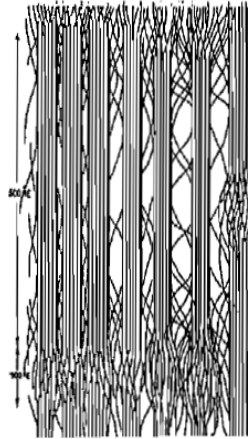

Dolmetsch 1968

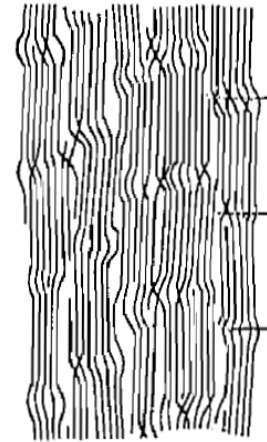

Hess and Kiessig 1953

# Semicrystallinity of microfibrils

- Original models were designed for all polymeric fibrils: synthetic, regenerated and native alike

Fringed micellar model

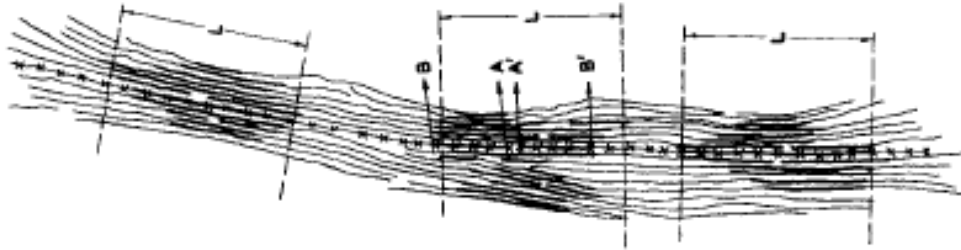

Mark J. *Phys. Chem.* **1940**, 44, 764.

Fringed fibrillar model

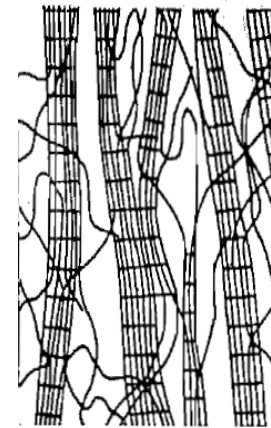

Hearle J. *Polym. Sci.* **1958**, 28, 432.

# Synthetic polymers vs. cellulose

- High resolution morphology by AFM

## Polyethylene

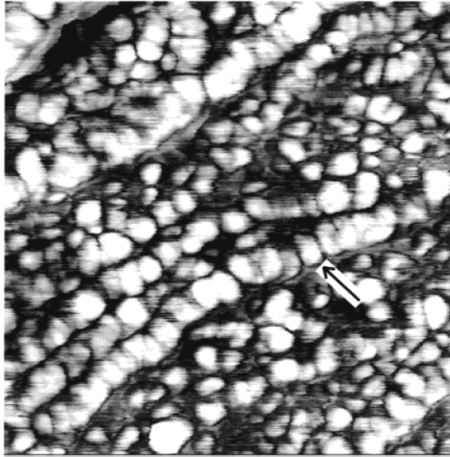

Amorphous segments visible

Loos et al. *Macromolecules* **1999**, 32, 8910.

## Cellulose microfibrils isolated from wood pulp

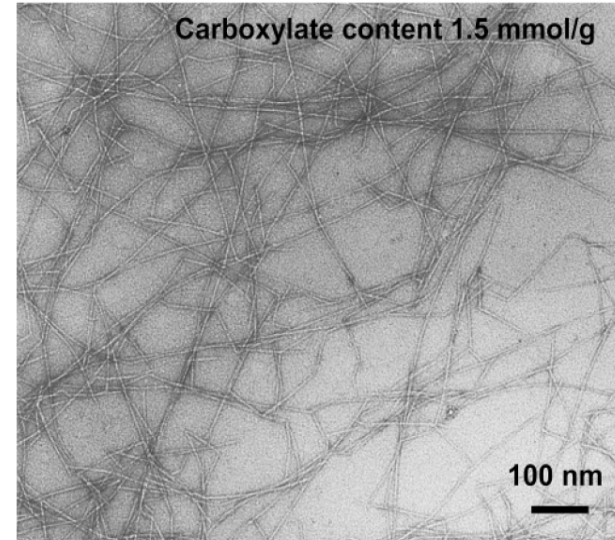

Amorphous segments **NOT** visible

# The original fringed fibrillar model

- Modern TEM images of microfibrils isolated by TEMPO-mediated oxidation do not support the Hearle model where fibrils are branched and polydisperse in width

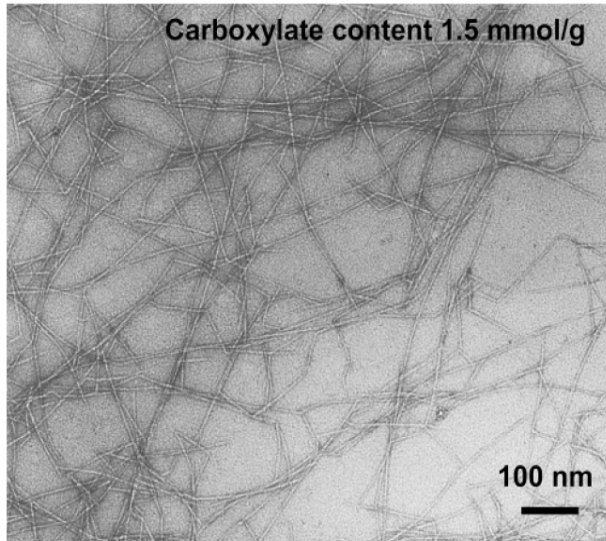

Fringed fibrillar model



Saito et al. *Biomacromolecules* **2006**, 7, 1687.  
Saito et al. *Biomacromolecules* **2007**, 8, 2485.

Hearle *J. Polym. Sci.* **1958**, 28, 432.

# More realistic picture of a microfibril

- “Amorphous” regions are more like defects between the crystallites
- Their length is probably very small (maybe 1-2 nm)

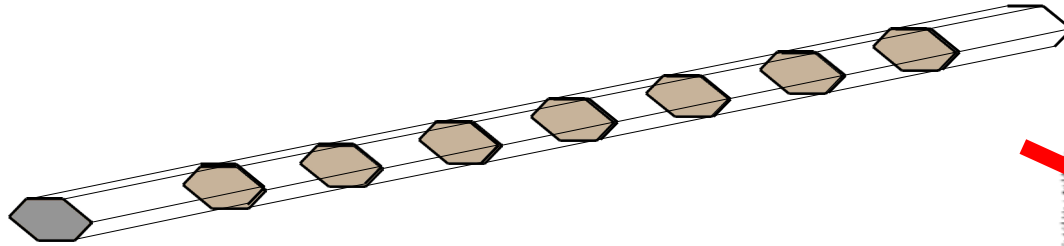

Defects: more realistic

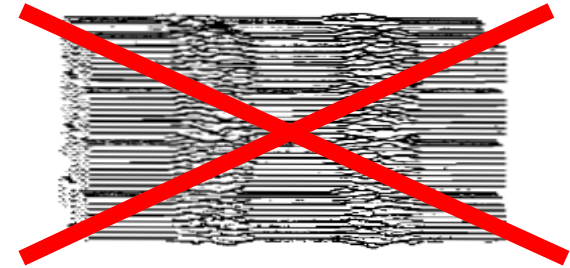

Bulky amorphous regions:  
less realistic

# Implications of fringed-fibrillar model

Alternating crystalline-amorphous regions explain well the macroscopic mechanical properties of cellulosic materials.

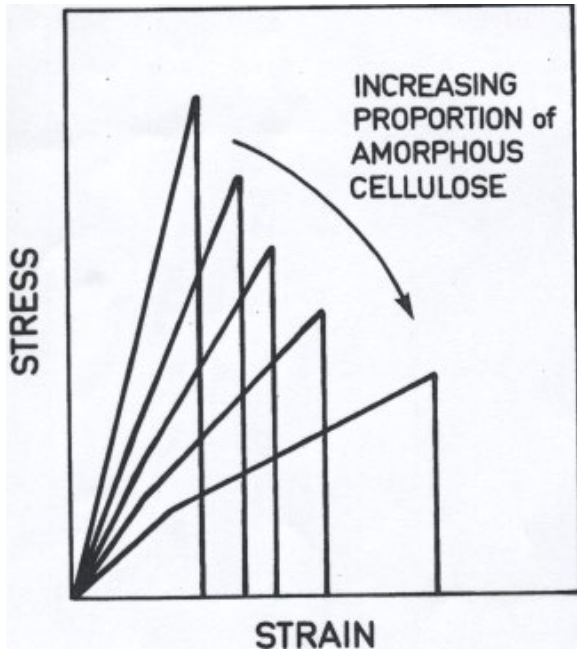

The length and width of the crystalline domains depend on the native source of the material.

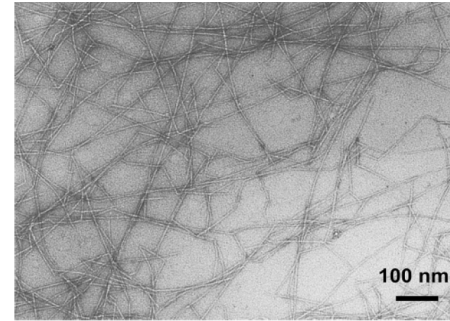

Elastic properties of isolated cellulose nanofibrils depend on their native source.

# Reservations with fringed fibrillar model

- When you see data of the *degree of crystallinity* or *crystallinity index* of cellulose, its physical meaning is unclear
- If the degree of crystallinity is, e.g., 64%, it does not mean that 64% of the cellulose is crystalline and 36% is "amorphous"
- Probably much of the material responsible for the "amorphous" response resides on the microfibril surface
- Cellulose I and cellulose II degrees of crystallinity should *not* be compared with each other
- Systematic sets of data can be compared with each other if the crystalline forms, the analytical method, and the raw materials are similar

# Levelling-off degree of polymerization (LODP)



# Acid hydrolysis of cellulose

- Acid hydrolysis involves the breakage of glycosidic bond by addition of water, catalyzed by acid
- High concentrations are required for complete degradation (e.g., 72% (w/w)  $\text{H}_2\text{SO}_4$ )

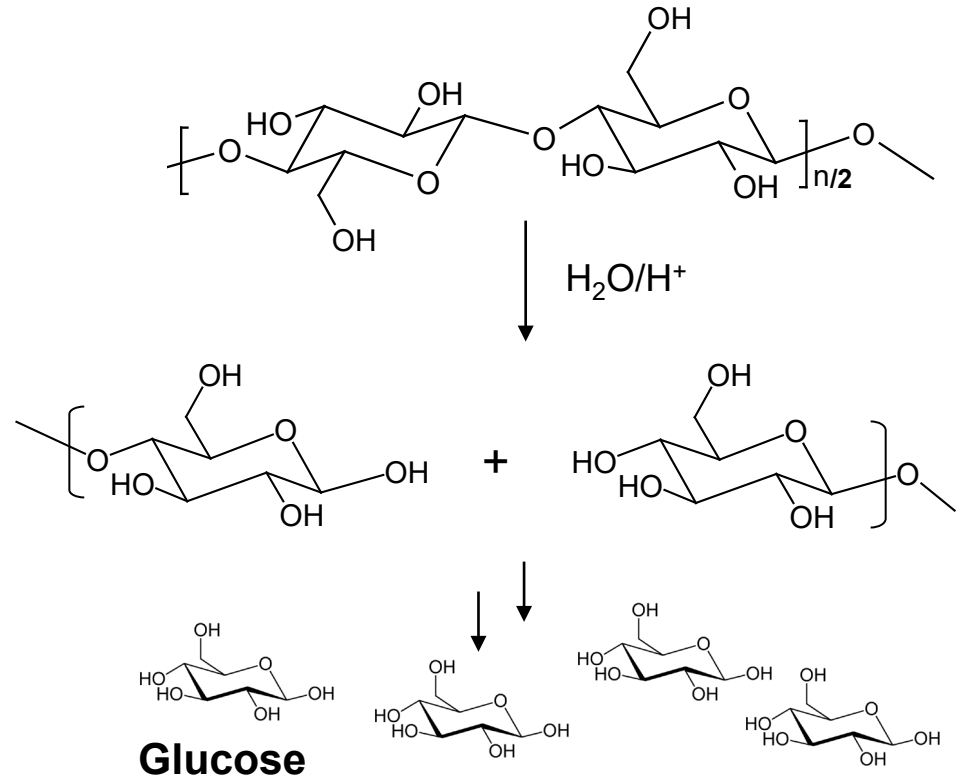

# Kinetics of acid hydrolysis of cellulose

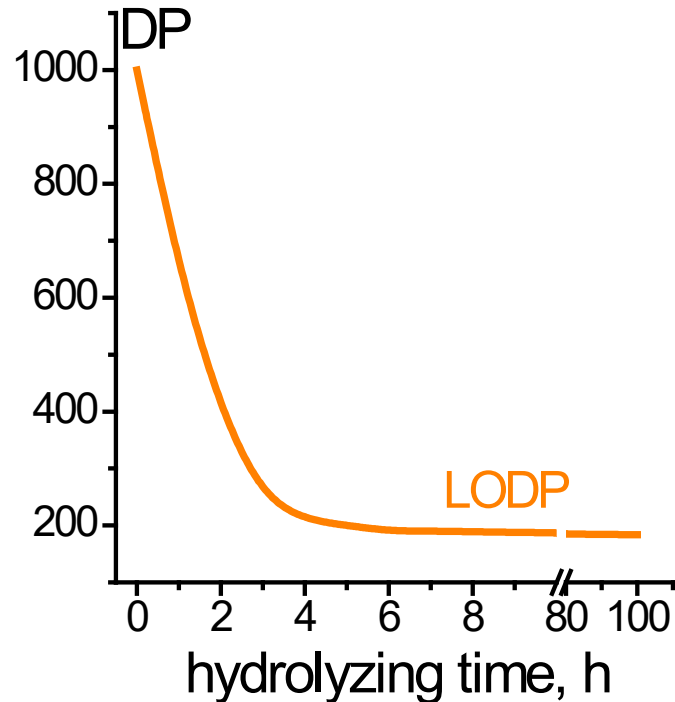

- When milder acid concentrations are used, DP first drops fast, after which it almost halts, hitting the LODP
- Traditionally LODP is determined with 2-3 M HCl at around 100°C
- Common explanation for LODP: “amorphous” regions are hydrolysed and crystallites are left intact

# LODP of different cellulose sources

Material	LODP
Wood pulp	100-250
Cotton linters	100-250
Ramie	200-350
Valonia	7000

**Notice the large variation in numbers for the same source**

# Molecular weight distribution at LODP

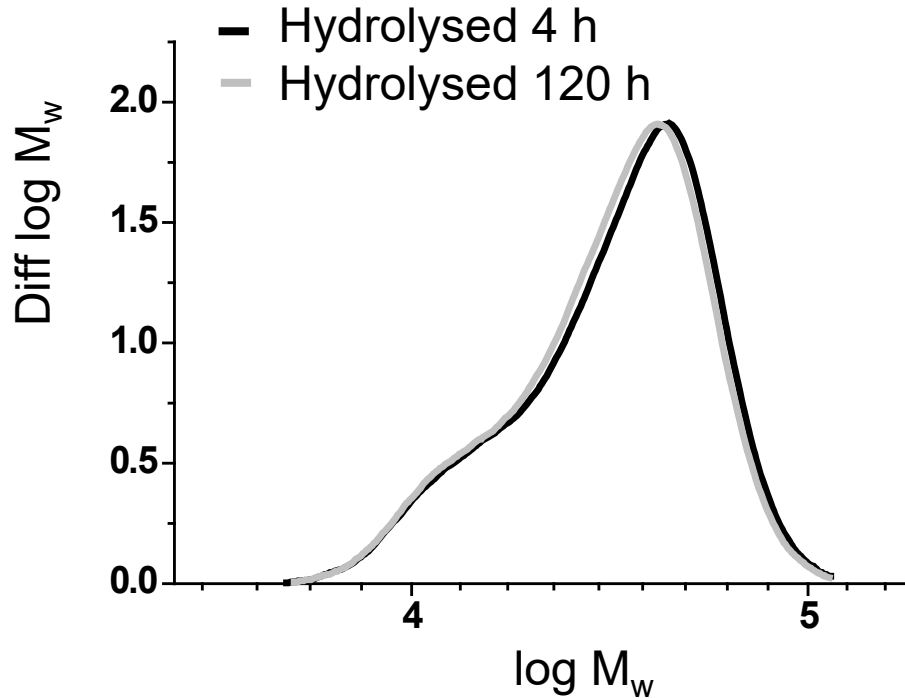

**Cotton linters LODP ~150**

**Notice: bimodal distribution**

# Discrepancies with LODP

Cellulose substrate and reference	LODP	Yield loss (%)	Conditions for determining LODP
Cotton linters	200-250	n.a.	2.5 N HCl, 105°C, 15 min
Cotton linters	187	7	2.5 N H <sub>2</sub> SO <sub>4</sub> , 96°C, 6 h
Cotton linters	253	2	2.5 N H <sub>2</sub> SO <sub>4</sub> , 100°C, 30 min
Cotton linters	190	4.4	2.4 N HCl, 100°C, 1 h
Cotton linters	100	6	6.5 N HCl, 108°C
Cotton linters	200	3.5	2.5 N HCl, 100°C, 30 min
Cotton linters	162	5	5% HCl, 95°C, 1 h

- No standard method to measure LODP exists
- Many different values for similar cellulose grades have been reported
- Amount of material lost during hydrolysis (yield loss) also varies a great deal

# Does LODP represent the length of the crystalline region?

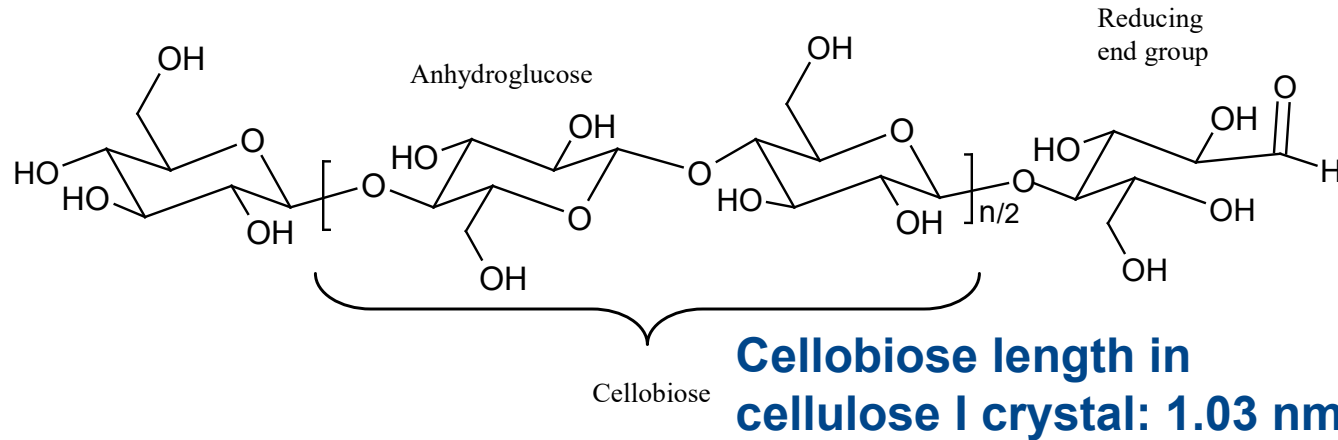

- Length calculated from LODP should correspond to crystallite length measured by XRD or NMR

# Crystallite length vs. LODP

Material	LODP	Crystal length by XRD*
Wood pulp	100-250	23 nm
Cotton linters	100-250	35 nm

- Crystal length determined from CMFs does not correlate with LODP
- Possible reason: diffraction and/or spectroscopy cannot detect the CMF twist and interprets it for a shorter crystallite

# Careful comparison of LODP and small angle neutron scattering

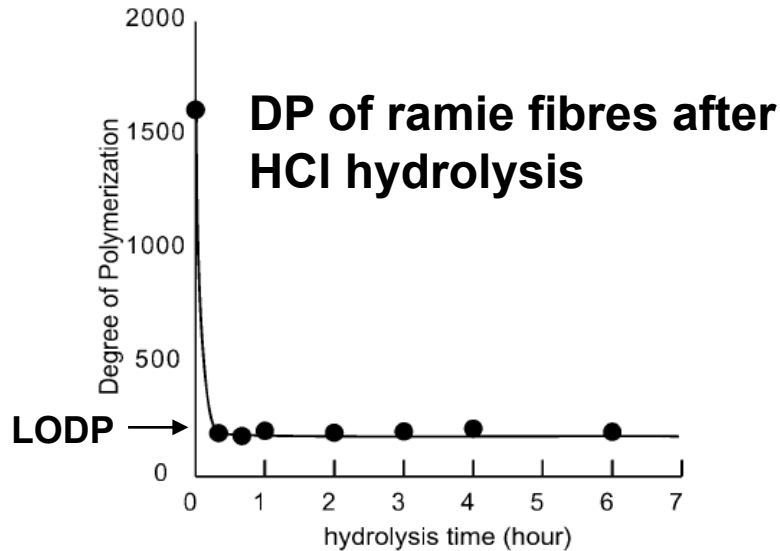

**Small angle neutron scattering (SANS) pattern of untreated ramie**

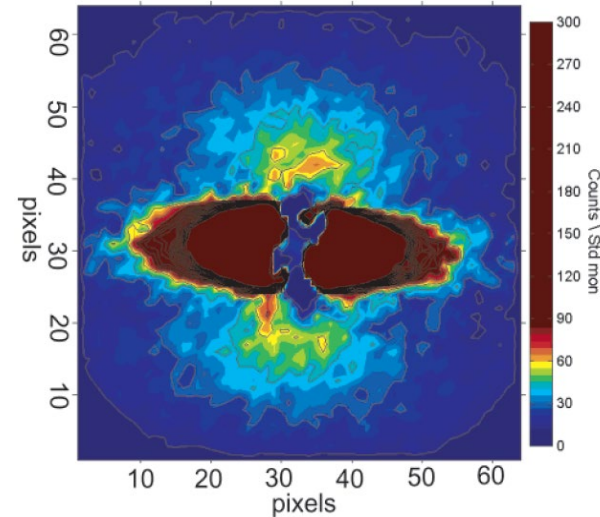

➔ Crystallite length (i.e. length of crystalline domains) by SANS agrees with the level-off degree of polymerization (LODP).



# Careful comparison of LODP and small angle neutron scattering

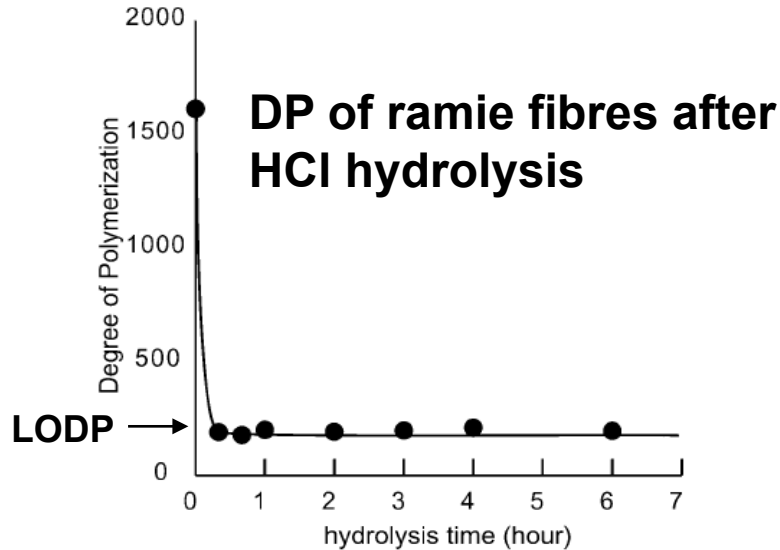

- The yield loss upon controlled acid hydrolysis is very small ( $\sim 1\%$ )
- This implies a very short disordered region (4-5 anhydroglucose units)
- Disordered – *not* amorphous

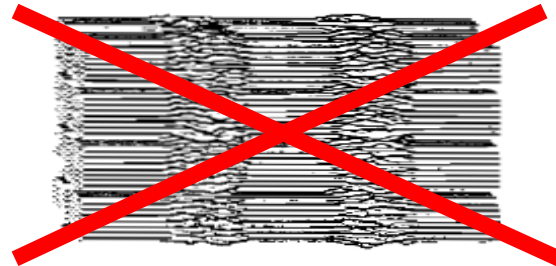

# Cellulose nanocrystals, LODP and crystallite length

# Principle of preparation

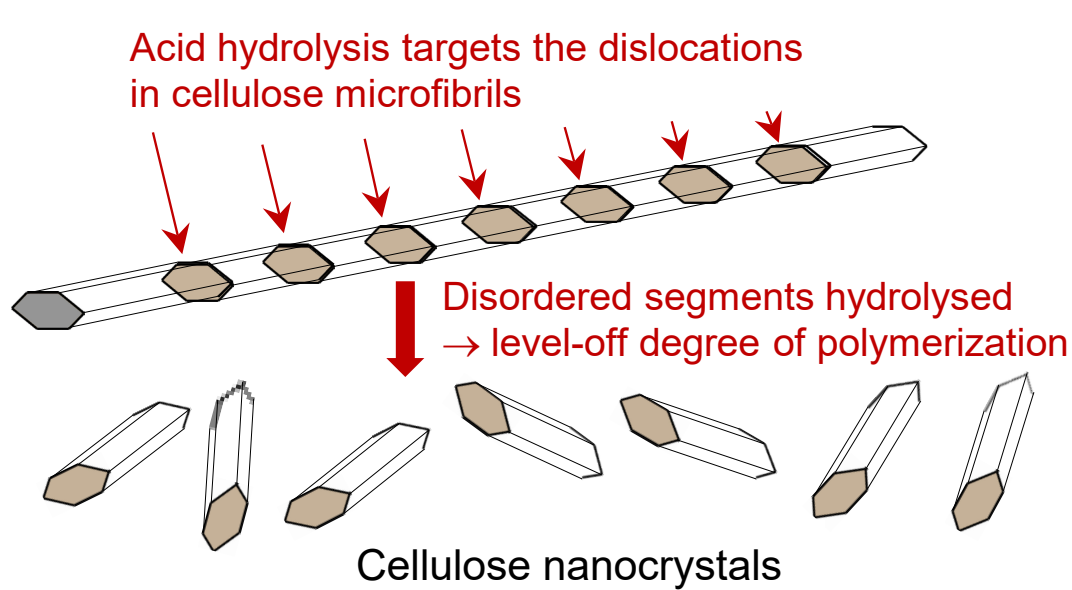

Cellulose nanocrystals

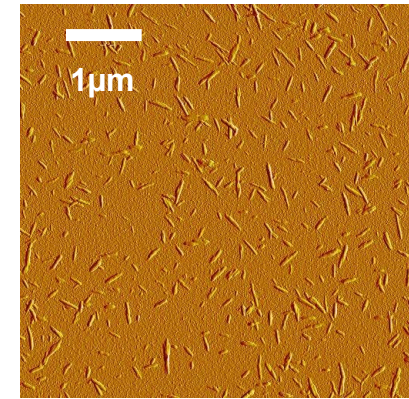

AFM image

Acid hydrolysis targets the disordered regions in a cellulose microfibril.



**Result: cellulose nanocrystals**

# Does the LODP correlate with cellulose nanocrystal length?

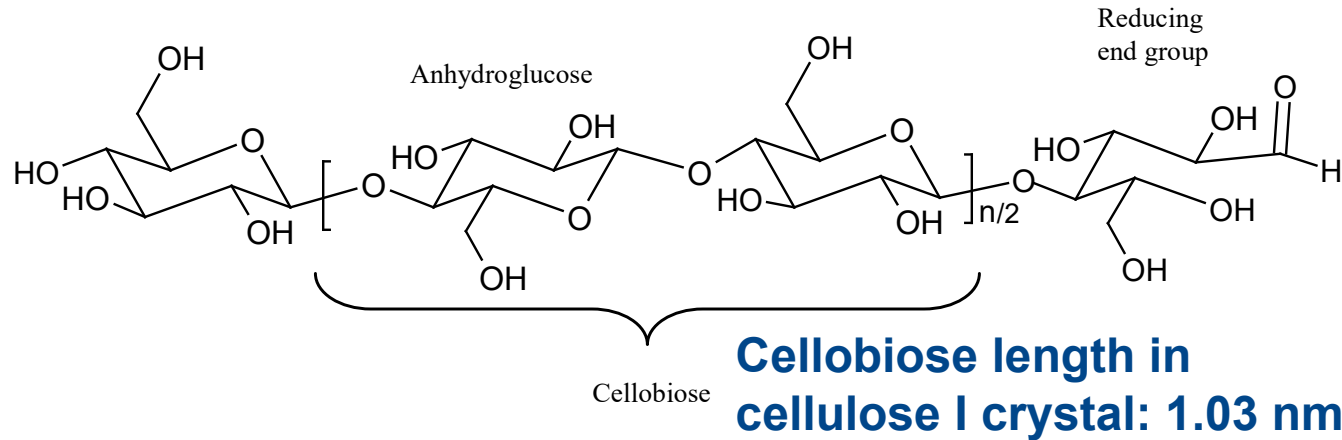

- Length calculated from LODP should correspond to the length of cellulose nanocrystals

# Does the LODP correlate with cellulose nanocrystal length?

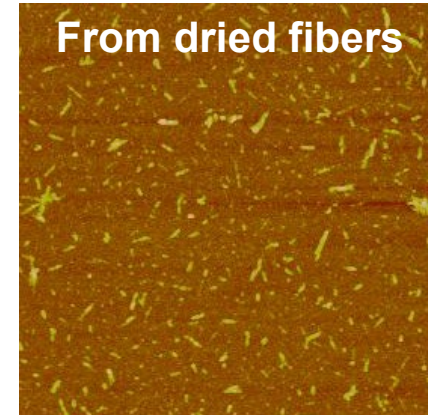
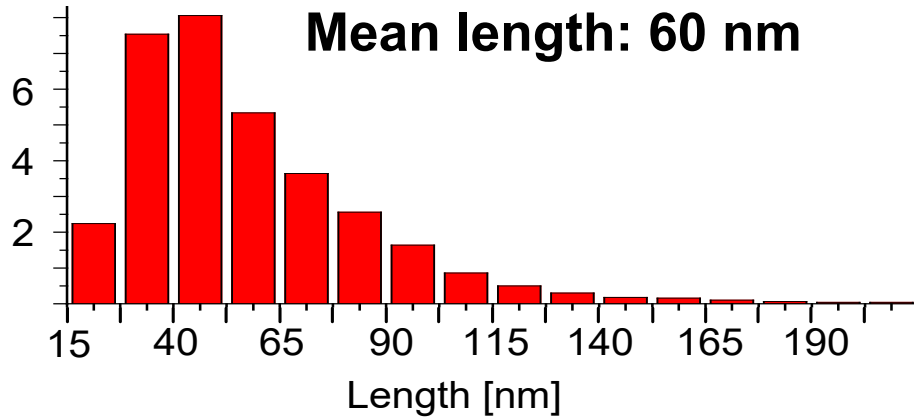

From wood pulp, the nanocrystal length correlates with LODP (~100)

# Does the LODP correlate with cellulose nanocrystal length?

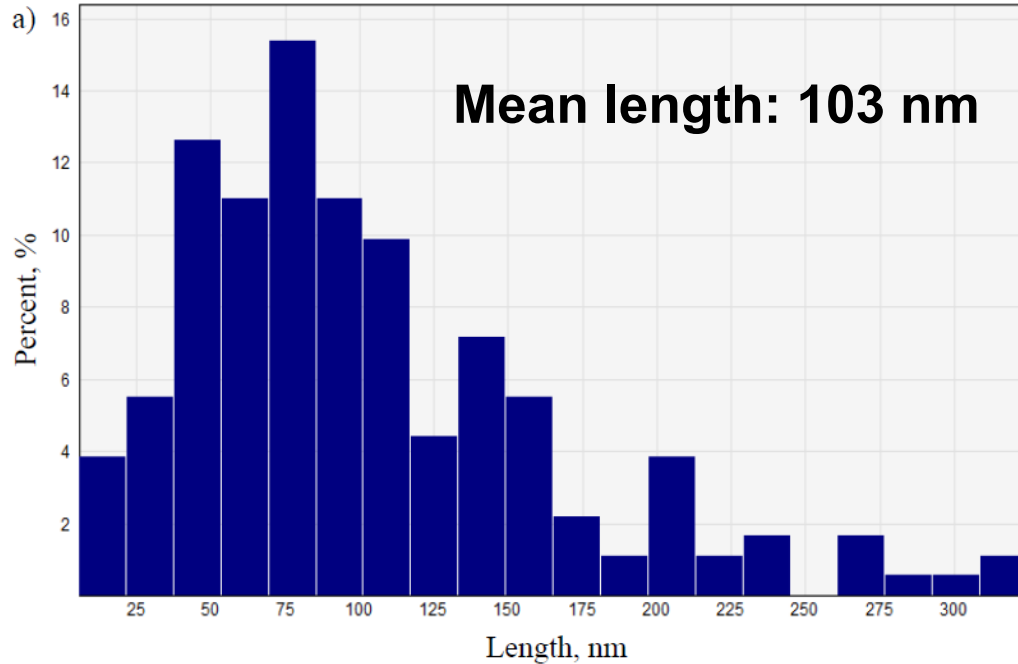

b)

Minimum	5.867026 nm
Maximum	324.957653 nm
Mean	102.923595 nm
Std. Dev.	63.087917 nm

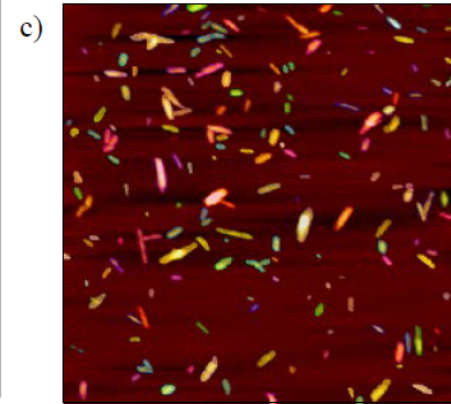

- From cotton linters, the nanocrystal length is slightly longer than LODP (~150)

# CNC length – comprehensive treatise

Cellulose source and reference	Hydrolysis conditions	Mean length of CNCs (nm)
Cotton linters	65 wt% H <sub>2</sub> SO <sub>4</sub> , 45°C, 30 min	163
Cotton linters	65 wt% H <sub>2</sub> SO <sub>4</sub> , 72°C, 30 min	128
Cotton linters	64 wt% H <sub>2</sub> SO <sub>4</sub> , 45°C, 45 min	226
Cotton linters	64 wt% H <sub>2</sub> SO <sub>4</sub> , 45°C, 240 min	177
Cotton linters	64 wt% H <sub>2</sub> SO <sub>4</sub> , 45°C, 45 min	103

LODP of cotton linters:  
100-250 (50-125 nm)

- LODP and CNC length do not match
- Yet systematic studies on the issue are lacking

# Implications of longer than LODP nanocrystals

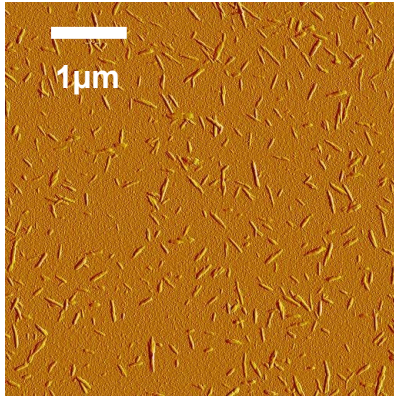

If LODP and nanocrystal lengths do not match:

- Nanocrystal hydrolysis is interrupted before LODP is reached
- Nanocrystals are probably not single crystals of cellulose



# Bundling of CMFs

# Appearance of CMFs

Aggregates: 12-20 nm

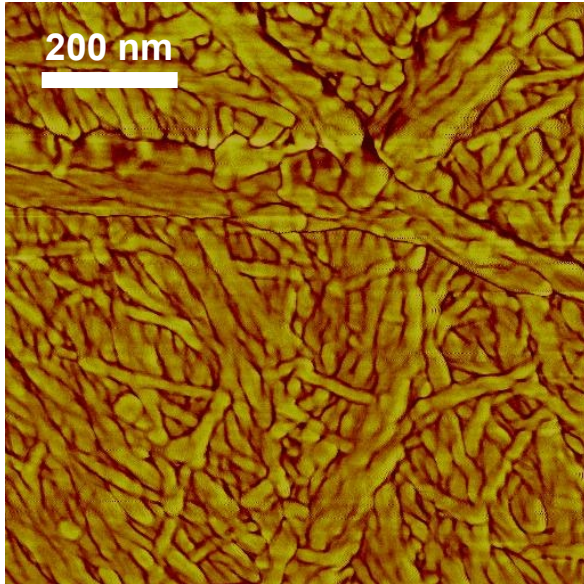

AFM image of a surface of bleached birch kraft pulp; sample untreated.

Individual microfibrils: ~3.5 nm



TEM image of longitudinal cross-section of chlorite delignified pine cell wall; freeze-dried and stained

# Appearance of CMFs

Aggregates: 12-20 nm

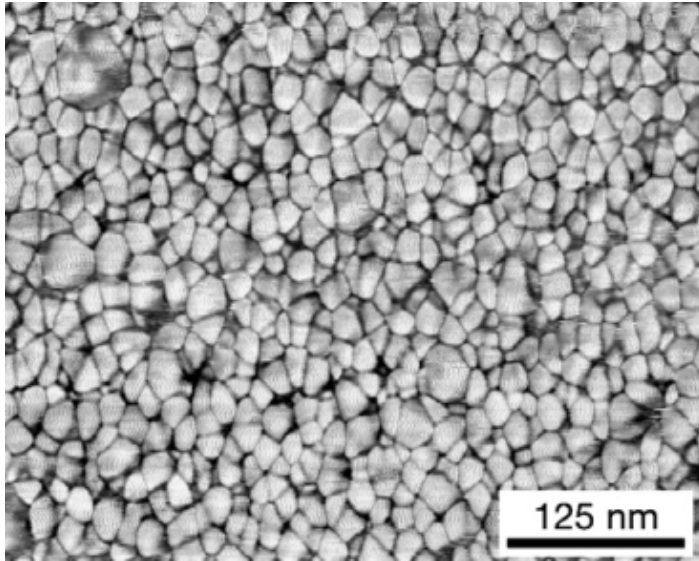

TEM image of radial cross-section of wood cell wall.

Individual microfibrils: ~3.5 nm



TEM image of longitudinal cross-section of chlorite delignified pine cell wall; freeze-dried and stained

# When does CMF bundling occur?

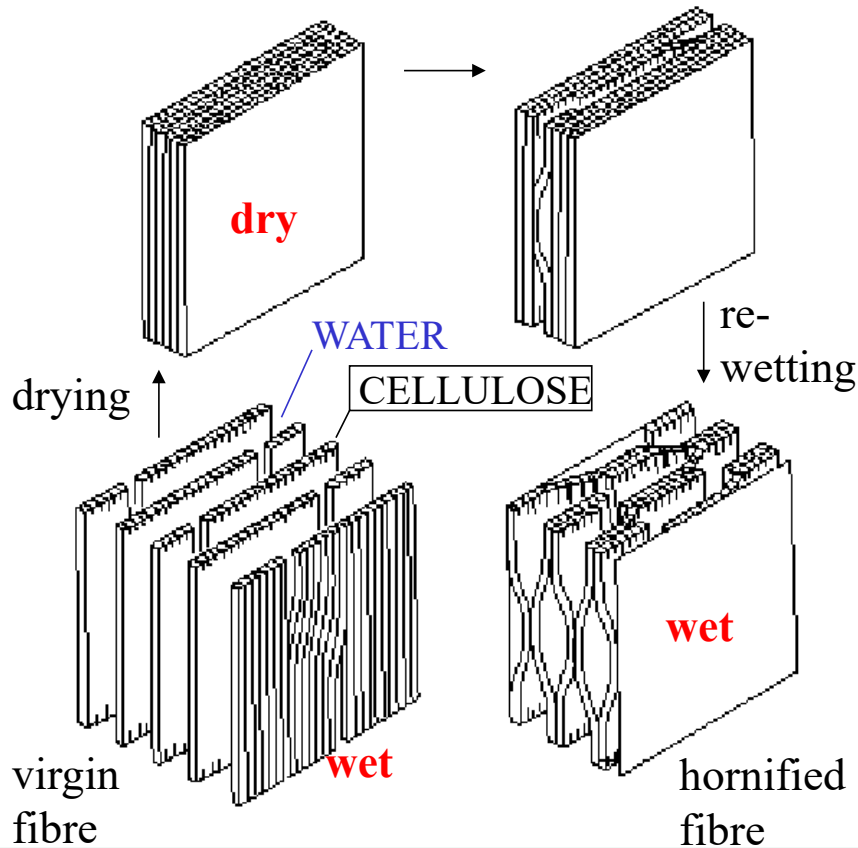

## Hornification

- Well-known phenomenon with chemical pulp fibres
- Water swells the fibres by penetrating between CMFs
  - Fibres are porous in water
- When dried, the pores disappear
- Upon rewetting, the swelling is not restored to the same level
  - Porosity is irreversibly decreased upon drying
  - CMFs have bundled

# When does CMF bundling occur?

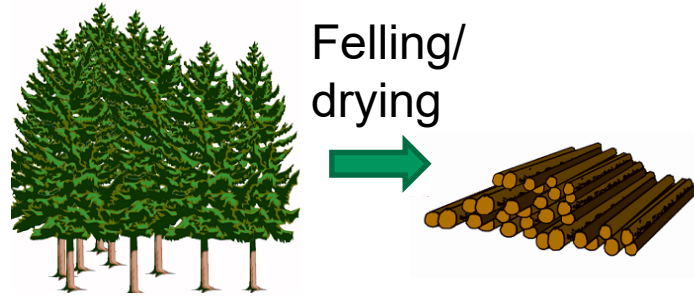

- Just removing a plant from its native growth environment causes CMF bundling (aggregation)

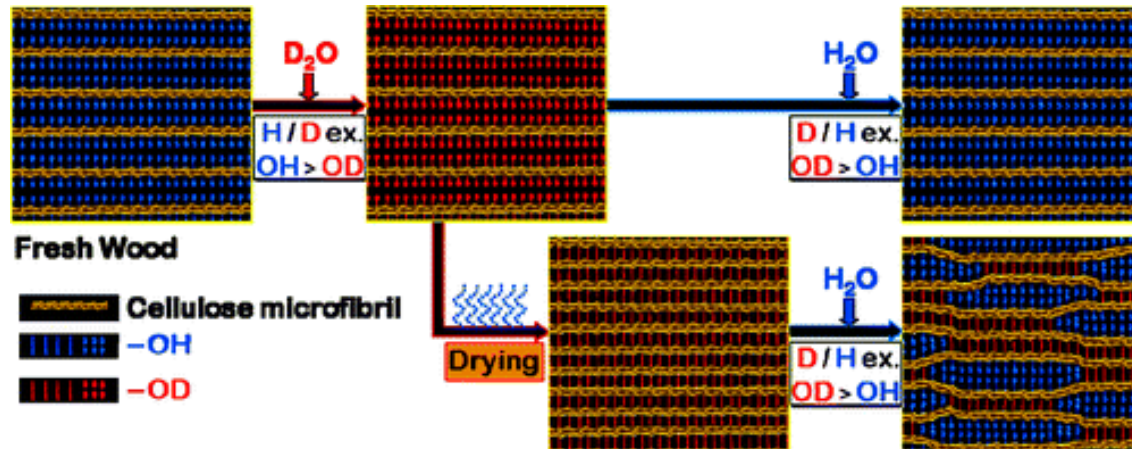

# Implications of CMF bundling

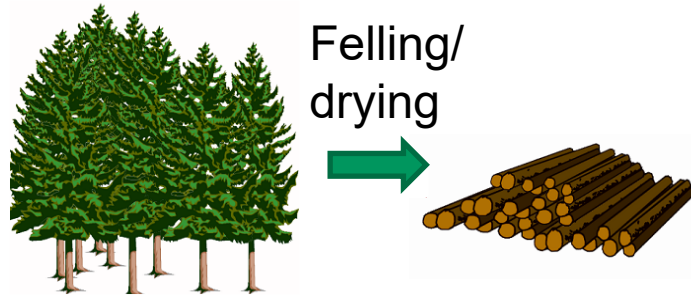

Aggregation

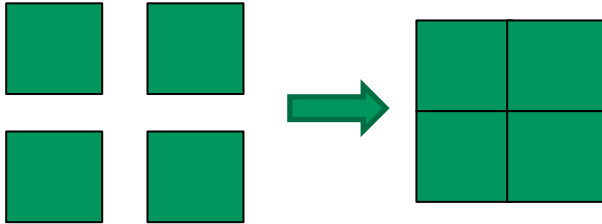

Schematic cross sections of microfibrils

Why is this important?



Reduced surface area



Reduced accessibility



**Fewer reaction sites**



**Difficulties to extract  
cellulose nanofibrils**

# Summary

- Native cellulose resides exclusively in cellulose microfibrils (CMFs)
- Width of CMFs is monodisperse but difficult to analyse unambiguously
- Number of cellulose chains in a CMF is not agreed upon
- Longitudinal disorder in CMF (fringed fibrillar model) does exist but the disordered regions are rather dislocations than bulky amorphous regions
- Levelling-off degree of polymerization, cellulose nanocrystal length, and the measured length of CMF crystalline regions do not match together perfectly
- CMFs have a tendency to bundle together upon drying