

ELEC-C1230 Säättötekniikka

Kaavakokoelma



Palauta tentin jälkeen, jos olet saanut

kokoelman valvojalta!

Älä tee mitään merkintöjä kaavakokoelmaan!

1 Dynaamisten mallien peruskomponentit

1.1 Sähköiset komponentit

Vastus (resistanssi)		$u(t) = Ri(t)$
Kela (induktanssi)		$u(t) = L \frac{di(t)}{dt}$
Kondensaattori (kapasitanssi)		$i(t) = C \frac{du(t)}{dt}$

1.2 Etenevä liike

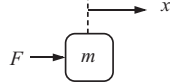
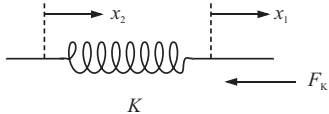
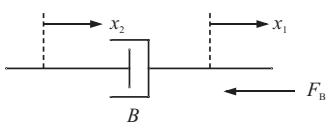
Massakappale		$ma(t) = m \frac{d^2x(t)}{dt^2}$ a on kiihtyvyyys
Jousi		$F_K = K\Delta x(t)$ $= K(x_1(t) - x_2(t))$
Vaimennin		$F_B = B\Delta v(t) = B \frac{d\Delta x(t)}{dt}$ $= B \left(\frac{dx_1(t)}{dt} - \frac{dx_2(t)}{dt} \right)$ v on nopeus

1.3 Pyörivä liike

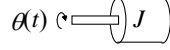
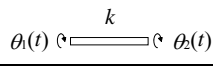
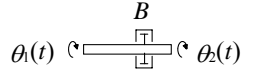
Hitausmomentti		$T_j(t) = J \frac{d^2\theta(t)}{dt^2}$
Vääntöjousi		$T_k(t) = k\Delta\theta(t)$ $= k(\theta_1(t) - \theta_2(t))$
Vääntövaimennin		$T_b(t) = B \frac{d\Delta\theta(t)}{dt}$ $= B \left(\frac{d\theta_1(t)}{dt} - \frac{d\theta_2(t)}{dt} \right)$

1.4 Virtausjärjestelmät

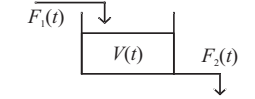
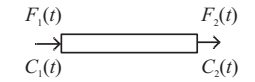
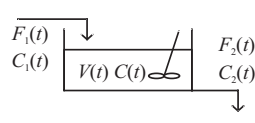
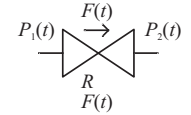
Säiliö		$\frac{dV(t)}{dt} = F_1(t) - F_2(t)$
Tulppavirtaus		$F_2(t) = F_1(t - T)$ $C_2(t) = C_1(t - T)$
Ideaalisekoitin		$\frac{dV(t)}{dt} = F_1(t) - F_2(t)$ $\frac{d(C(t)V(t))}{dt} = C_1(t)F_1(t) - C_2(t)F_2(t)$ $C_2(t) = C(t)$
Venttiili (aukko)		$F(t) = A(t)R\sqrt{\Delta P(t)}$ (turbulenti) $F(t) = A(t)R\Delta P(t)$ (laminaari)

2 Tilaesitys

Järjestelmä:

$$y^{(n)}(t) + a_1y^{(n-1)}(t) + \dots + a_{n-1}y^{(1)}(t) + a_ny(t) = b_1u^{(n-1)}(t) + \dots + b_{n-1}u^{(1)}(t) + b_nu(t)$$

Yleinen tilaesitys:
$$\begin{cases} \dot{\mathbf{x}}(t) = \mathbf{f}(\mathbf{x}(t), \mathbf{u}(t)) \\ \mathbf{y}(t) = \mathbf{g}(\mathbf{x}(t), \mathbf{u}(t)) \end{cases}$$

Lineaarinen tilaesitys:
$$\begin{cases} \dot{\mathbf{x}}(t) = \mathbf{f}(\mathbf{x}(t), \mathbf{u}(t)) = \mathbf{Ax}(t) + \mathbf{Bu}(t) \\ \mathbf{y}(t) = \mathbf{g}(\mathbf{x}(t), \mathbf{u}(t)) = \mathbf{Cx}(t) + \mathbf{Du}(t) \end{cases}$$

2.1 Linearisointi

Olkoon yleisen tilaesityksen tasapainotila $(\mathbf{x}_s, \mathbf{u}_s)$. Tasapainotilaan linearisoitu tilaesitys on tällöin

$$\begin{cases} \Delta\dot{\mathbf{x}}(t) = \frac{d\mathbf{f}}{d\mathbf{x}^T}(\mathbf{x}_s, \mathbf{u}_s) \cdot \Delta\mathbf{x}(t) + \frac{d\mathbf{f}}{d\mathbf{u}^T}(\mathbf{x}_s, \mathbf{u}_s) \cdot \Delta\mathbf{u}(t) \\ \Delta\mathbf{y}(t) = \frac{d\mathbf{g}}{d\mathbf{x}^T}(\mathbf{x}_s, \mathbf{u}_s) \cdot \Delta\mathbf{x}(t) + \frac{d\mathbf{g}}{d\mathbf{u}^T}(\mathbf{x}_s, \mathbf{u}_s) \cdot \Delta\mathbf{u}(t) \end{cases}$$

$$\frac{df}{dz^T}(\mathbf{z}) = \begin{bmatrix} \frac{df_1}{dz_1}(\mathbf{z}) & \frac{df_1}{dz_2}(\mathbf{z}) & \dots & \frac{df_1}{dz_m}(\mathbf{z}) \\ \frac{df_2}{dz_1}(\mathbf{z}) & \frac{df_2}{dz_2}(\mathbf{z}) & & \\ \vdots & & \ddots & \\ \frac{df_n}{dz_1}(\mathbf{z}) & & & \frac{df_n}{dz_m}(\mathbf{z}) \end{bmatrix}$$

2.2 Kanoniset muodot

$$\text{Ohjattava kanoninen tilaesitys: } \begin{cases} \dot{\mathbf{x}}(t) = \begin{bmatrix} 0 & 1 & 0 & \dots & 0 \\ 0 & 0 & 1 & & \vdots \\ \vdots & \vdots & & \ddots & 0 \\ 0 & 0 & & 0 & 1 \\ -a_n & -a_{n-1} & \dots & -a_2 & -a_1 \end{bmatrix} \mathbf{x}(t) + \begin{bmatrix} 0 \\ 0 \\ \vdots \\ 0 \\ 1 \end{bmatrix} u(t) \\ \mathbf{y}(t) = [b_n \ b_{n-1} \ \dots \ b_2 \ b_1] \mathbf{x}(t) \end{cases}$$

$$\text{Havaittava kanoninen tilaesitys: } \begin{cases} \dot{\mathbf{x}}(t) = \begin{bmatrix} -a_1 & 1 & 0 & \dots & 0 \\ -a_2 & 0 & 1 & & \vdots \\ \vdots & \vdots & & \ddots & 0 \\ -a_{n-1} & 0 & & 0 & 1 \\ -a_n & 0 & \dots & 0 & 0 \end{bmatrix} \mathbf{x}(t) + \begin{bmatrix} b_1 \\ b_2 \\ \vdots \\ b_{n-1} \\ b_n \end{bmatrix} u(t) \\ \mathbf{y}(t) = [1 \ 0 \ \dots \ 0 \ 0] \mathbf{x}(t) \end{cases}$$

2.3 Lineaarisen tilaesityksen ratkaisu

$$\Phi(t) = e^{\mathbf{A}t}, \quad \Phi(t) = e^{\mathbf{A}t} = L^{-1} \{ (s\mathbf{I} - \mathbf{A})^{-1} \}$$

$$\begin{cases} \mathbf{x}(t) = \Phi(t)\mathbf{x}(0) + \int_0^t \Phi(t-\tau)\mathbf{B}u(\tau)d\tau \\ \mathbf{y}(t) = \mathbf{C}\mathbf{x}(t) + \mathbf{D}u(t) \end{cases}$$

$$\mathbf{y}(t) = (\mathbf{C}\Phi(t)\mathbf{x}(0)) + \left(\mathbf{C} \int_0^t \Phi(t-\tau)\mathbf{B}u(\tau)d\tau + \mathbf{D}u(t) \right) = \mathbf{y}_o(t) + \mathbf{y}_u(t)$$

2.4 Ohjattavuus ja havaittavuus

Ohjattavuusmatriisi:

$$\mathbf{M}_c = [\mathbf{B} \mid \mathbf{A}\mathbf{B} \mid \mathbf{A}^2\mathbf{B} \mid \dots \mid \mathbf{A}^{n-1}\mathbf{B}]$$

Havaittavuusmatriisi:

$$\mathbf{M}_o = \begin{bmatrix} \mathbf{C} \\ \mathbf{C}\mathbf{A} \\ \mathbf{C}\mathbf{A}^2 \\ \vdots \\ \mathbf{C}\mathbf{A}^{n-1} \end{bmatrix}$$

2.5 Tilasäätö

Järjestelmä:

$$\begin{cases} \dot{\mathbf{x}}(t) = \mathbf{A}\mathbf{x}(t) + \mathbf{B}u(t) \\ \mathbf{y}(t) = \mathbf{C}\mathbf{x}(t) \end{cases}$$

Takaisinkytkentä lähtösuureesta:

$$\mathbf{u}(t) = \mathbf{Tr}(t) - \mathbf{K}\mathbf{y}(t) = \mathbf{Tr}(t) - \mathbf{K}\mathbf{C}\mathbf{x}(t)$$

$$\Rightarrow \begin{cases} \dot{\mathbf{x}}(t) = \mathbf{A}\mathbf{x}(t) + \mathbf{B}(\mathbf{Tr}(t) - \mathbf{K}\mathbf{C}\mathbf{x}(t)) = (\mathbf{A} - \mathbf{B}\mathbf{K}\mathbf{C})\mathbf{x}(t) + \mathbf{B}\mathbf{Tr}(t) = \mathbf{A}^* \mathbf{x}(t) + \mathbf{B}^* \mathbf{r}(t) \\ \mathbf{y}(t) = \mathbf{C}\mathbf{x}(t) \end{cases}$$

Takaisinkytkentä tilasuureesta:

$$\mathbf{u}(t) = \mathbf{Tr}(t) - \mathbf{L}\mathbf{x}(t)$$

$$\Rightarrow \begin{cases} \dot{\mathbf{x}}(t) = \mathbf{A}\mathbf{x}(t) + \mathbf{B}(\mathbf{Tr}(t) - \mathbf{L}\mathbf{x}(t)) = (\mathbf{A} - \mathbf{B}\mathbf{L})\mathbf{x}(t) + \mathbf{B}\mathbf{Tr}(t) = \mathbf{A}^* \mathbf{x}(t) + \mathbf{B}^* \mathbf{r}(t) \\ \mathbf{y}(t) = \mathbf{C}\mathbf{x}(t) \end{cases}$$

Integraattorin augmentointi tilasäätimeen:

$$\begin{cases} \mathbf{u}(t) = -\mathbf{L}\mathbf{x}(t) - \mathbf{L}_I \mathbf{x}_I(t) \\ \dot{\mathbf{x}}_I(t) = -\mathbf{C}\mathbf{x}(t) + \mathbf{y}_{ref}(t) \end{cases}$$

$$\Rightarrow \begin{cases} \begin{bmatrix} \dot{\mathbf{x}}(t) \\ \dot{\mathbf{x}}_I(t) \end{bmatrix} = \begin{bmatrix} \mathbf{A} - \mathbf{B}\mathbf{L} & -\mathbf{B}\mathbf{L}_I \\ -\mathbf{C} & \mathbf{0} \end{bmatrix} \begin{bmatrix} \mathbf{x}(t) \\ \mathbf{x}_I(t) \end{bmatrix} + \begin{bmatrix} \mathbf{0} \\ \mathbf{I} \end{bmatrix} \mathbf{y}_{ref}(t) \\ \mathbf{y}(t) = [\mathbf{C} \mid \mathbf{0}] \begin{bmatrix} \mathbf{x}(t) \\ \mathbf{x}_I(t) \end{bmatrix} \end{cases} \Rightarrow \begin{cases} \dot{\mathbf{x}}^*(t) = \mathbf{A}^* \mathbf{x}^*(t) + \mathbf{B}^* \mathbf{y}_{ref}(t) \\ \mathbf{y}(t) = \mathbf{C}^* \mathbf{x}^*(t) \end{cases}$$

Karakteristinen yhtälö:

$$\det(s\mathbf{I} - \mathbf{A}^*) = \det \left[\begin{array}{c|c} s\mathbf{I} - \mathbf{A} + \mathbf{B}\mathbf{L} & \mathbf{B}\mathbf{L}_I \\ \hline \mathbf{C} & s\mathbf{I} \end{array} \right] = 0$$

2.6 Tilaestimointi

$$\begin{cases} \mathbf{x}(t) & \text{todellinen tila} \\ \hat{\mathbf{x}}(t) & \text{tilaestimaatti} \\ \tilde{\mathbf{x}}(t) & \text{estimaatin poikkeama} \end{cases}$$

Tilähavaintaja:

$$\begin{aligned}\dot{\hat{\mathbf{x}}}(t) &= \mathbf{A}\hat{\mathbf{x}}(t) + \mathbf{B}\mathbf{u}(t) + \mathbf{K}\hat{\mathbf{e}}(t) = \mathbf{A}\hat{\mathbf{x}}(t) + \mathbf{B}\mathbf{u}(t) + \mathbf{K}(\mathbf{y}(t) - \mathbf{C}\hat{\mathbf{x}}(t)) \\ &= (\mathbf{A} - \mathbf{K}\mathbf{C})\hat{\mathbf{x}}(t) + \mathbf{B}\mathbf{u}(t) + \mathbf{K}\mathbf{y}(t)\end{aligned}$$

Estimointivirheen dynamiikka:

$$\dot{\hat{\mathbf{x}}}(t) = (\mathbf{A} - \mathbf{K}\mathbf{C})\hat{\mathbf{x}}(t) = \mathbf{A}'\hat{\mathbf{x}}(t)$$

2.7 Tilaestimointi ja -säätö yhdistettynä

$$\begin{cases} \begin{bmatrix} \dot{\hat{\mathbf{x}}}(t) \\ \dot{\tilde{\mathbf{x}}}(t) \end{bmatrix} = \begin{bmatrix} \mathbf{A} - \mathbf{B}\mathbf{L} & \mathbf{B}\mathbf{L} \\ \mathbf{0} & \mathbf{A} - \mathbf{K}\mathbf{C} \end{bmatrix} \begin{bmatrix} \hat{\mathbf{x}}(t) \\ \tilde{\mathbf{x}}(t) \end{bmatrix} + \begin{bmatrix} \mathbf{B}\mathbf{T} \\ \mathbf{0} \end{bmatrix} \mathbf{r}(t) \\ \mathbf{y}(t) = [\mathbf{C} \mid \mathbf{0}] \begin{bmatrix} \hat{\mathbf{x}}(t) \\ \tilde{\mathbf{x}}(t) \end{bmatrix} \end{cases}$$

Karakteristinen yhtälö:

$$\det(s\mathbf{I} - \mathbf{A} + \mathbf{B}\mathbf{L}) \cdot \det(s\mathbf{I} - \mathbf{A} + \mathbf{K}\mathbf{C}) = 0$$

3 Siirtofunktio

Siirtofunktio: $G(s) = \frac{Y(s)}{U(s)}$

Lähtösuure: $y(t) = L^{-1}\{G(s) \cdot L\{u(t)\}\}$

Staattinen vahvistus: $\bar{k} = \lim_{s \rightarrow 0} \{G(s)\}$

Tilaisyyksestä siirtofunktion: $\mathbf{G}(s) = \mathbf{C}(s\mathbf{I} - \mathbf{A})^{-1}\mathbf{B} + \mathbf{D}$

3.1 Ensimmäisen kertaluvun dynamiikka

$$\tau \dot{y}(t) + y(t) = Ku(t) \quad G(s) = \frac{K}{\tau s + 1}$$

Impulssivaste: $y(t) = \frac{K}{\tau} e^{-\frac{t}{\tau}}$

Askelvaste: $y(t) = K \left(1 - e^{-\frac{t}{\tau}}\right)$

3.2 Toisen kertaluvun dynamiikka

$$\ddot{y}(t) + 2\zeta\omega_n \dot{y}(t) + \omega_n^2 y(t) = K\omega_n^2 u(t) \quad G(s) = \frac{K\omega_n^2}{s^2 + 2\zeta\omega_n s + \omega_n^2}$$

Ominaistaajuus:

$$\omega_n$$

Vaimennussuhde:

$$\zeta = \cos(\alpha)$$

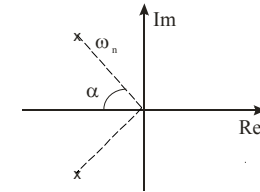

Aikataso:

Impulssivaste: $y(t) = \frac{K\omega_n}{\sqrt{1-\zeta^2}} e^{-\zeta\omega_n t} \left(\sin(\omega_n \sqrt{1-\zeta^2} t)\right)$

Askelvaste: $y(t) = K \left(1 - e^{-\zeta\omega_n t} \left(\cos(\omega_n \sqrt{1-\zeta^2} t) + \frac{\zeta}{\sqrt{1-\zeta^2}} \sin(\omega_n \sqrt{1-\zeta^2} t)\right)\right)$
 $= K \left(1 - \frac{1}{\sqrt{1-\zeta^2}} e^{-\zeta\omega_n t} \left(\sin(\omega_n \sqrt{1-\zeta^2} t + \arccos(\zeta))\right)\right)$

Askelvasteen ylitys:

$$\%OS = 100e^{-\left(\frac{\pi\zeta}{\sqrt{1-\zeta^2}}\right)}$$

Huipun ajankohta:

$$t_p = \frac{\pi}{\omega_n \sqrt{1-\zeta^2}}$$

Askelvasteen asettumisaika:

$$t_s(2\%) \approx \begin{cases} \frac{4}{\zeta\omega_n}, & \zeta \leq 0.88 \\ \frac{10\zeta - 4.2}{\omega_n}, & 0.88 < \zeta \leq 1.4 \end{cases} \quad t_s(5\%) \approx \begin{cases} \frac{3}{\zeta\omega_n}, & \zeta \leq 0.83 \\ \frac{7\zeta - 2.2}{\omega_n}, & 0.83 < \zeta \leq 1.4 \end{cases}$$

Taajuustaso:

Resonanssiipiikin taajuus:

$$\omega_r = \omega_n \sqrt{1-2\zeta^2}$$

Resonanssiipiikin korkeus:

$$M_r = \frac{1}{2\zeta\sqrt{1-\zeta^2}}$$

3 dB:n kaistanleveys:

$$BW = \omega_n \left[(1-2\zeta^2) + \sqrt{4\zeta^4 - 4\zeta^2 + 2} \right]^{\frac{1}{2}}$$

Pysyvä poikkeama:

$$G_{OL}(s) = \frac{P(s)}{Q(s)} = \frac{P(s)}{s^k \cdot Q^*(s)}$$

$Q^*(s) = 0$:llä ei ole juuria origossa

$$k = 0: K_p = \lim_{s \rightarrow 0} \{G_{OL}(s)\}$$

$$k = 1: K_v = \lim_{s \rightarrow 0} \{s \cdot G_{OL}(s)\}$$

$$k = 2: K_a = \lim_{s \rightarrow 0} \{s^2 \cdot G_{OL}(s)\}$$

k	Heräte		
	a_0	$a_1 t$	$a_2 t^2$
0	$\frac{a_0}{1 + K_p}$	$\pm\infty$	$\pm\infty$
1	0	$\frac{a_1}{K_v}$	$\pm\infty$
2	0	0	$\frac{2a_2}{K_a}$

Pysyvä poikkeama

Yksikköaskelvasteen prosentuaalinen ylitys ja vaihevara vaimennussuhteen funktiona:

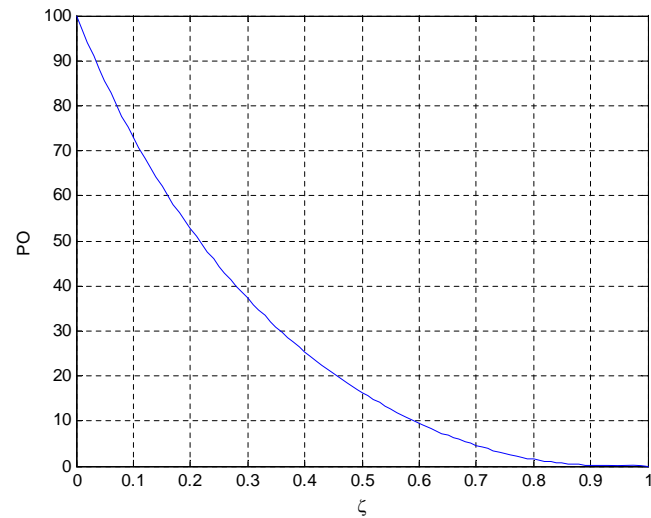

PO: Prosentuaalinen ylitys:

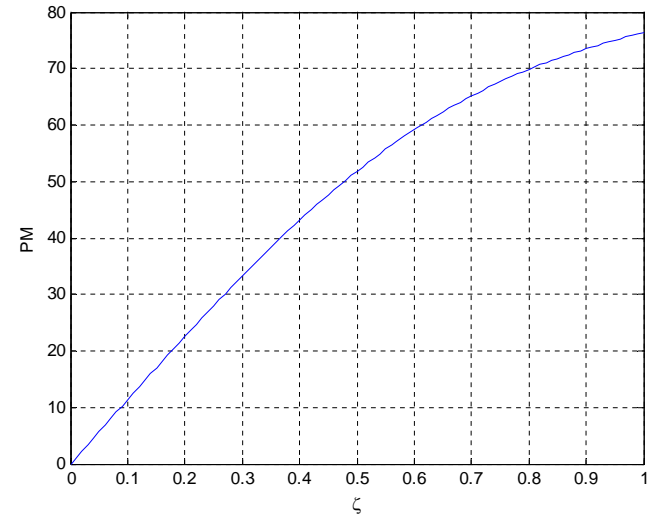

PM: Vaihevara (asteina)

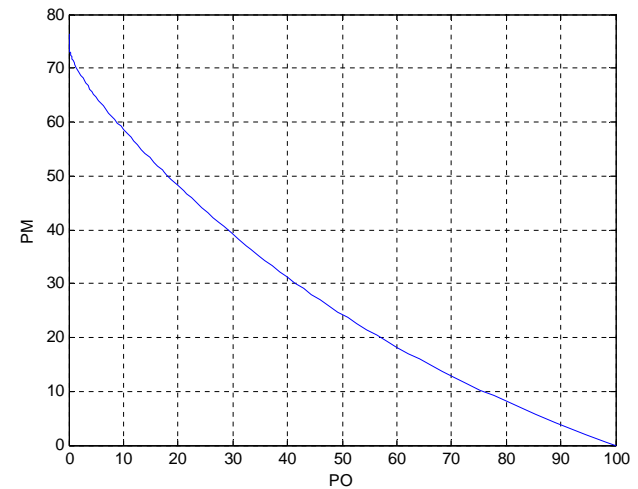

PO: Prosentuaalinen ylitys

PM: Vaihevara (asteina)

4 Navat ja nollat

Siirtofunktio

$$G(s) = \frac{b_1 s^{n-1} + b_2 s^{n-2} + \dots + b_{n-2} s^2 + b_{n-1} s + b_n}{s^{n_p} + a_1 s^{n_p-1} + a_2 s^{n_p-2} + \dots + a_{n_p-2} s^2 + a_{n_p-1} s + a_{n_p}} = \frac{P(s)}{Q(s)}$$

Tilaisiys

$$\begin{cases} Q(s) = \det(s\mathbf{I} - \mathbf{A}) \\ P(s) = \mathbf{C} \operatorname{adj}(s\mathbf{I} - \mathbf{A}) \mathbf{B} + \mathbf{D} \det(s\mathbf{I} - \mathbf{A}) \end{cases}$$

Karakteristinen yhtälö: $Q(s) = 0$

4.1 Juuriura

Karakteristinen yhtälö: $1 + KG_{OL}(s) = 0$

Juuriura: $G_{OL}(s_{p_i}) = -1$

$$|G_{OL}(s_{p_i})| = 1, \quad \angle\{G_{OL}(s_{p_i})\} = \pi + k \cdot 2\pi, \quad k = 0, \pm 1, \pm 2, \dots$$

Asymptootien kulmat:

$$\alpha = \pm \frac{(2k+1) \cdot 180}{P-Z}$$

Asymptootien leikkauspisteet reaaliakselilla:

$$\delta = \frac{\sum_{i=1}^P s_{p_i} - \sum_{i=1}^Z s_{z_i}}{P-Z}$$

Juuriuran haarojen yhtymis- ja erkanemispisteet:

$$\frac{dK}{ds} = 0$$

4.2 Routhin kaavio

$$a_0 s^n + a_1 s^{n-1} + \dots + a_{n-1} s + a_n$$

s^n	a_0	a_2	a_4	a_6	a_8	\dots
s^{n-1}	a_1	a_3	a_5	a_7	a_9	\dots
s^{n-2}	b_0	b_2	b_4	b_6	b_8	\dots
s^{n-3}	b_1	b_3	b_5	b_7	\dots	\dots
s^{n-4}	c_0	c_2	c_4	\dots	\dots	\dots
s^{n-5}	c_1	c_3	c_5	\dots	\dots	\dots
\vdots	\vdots	\vdots	\vdots	\vdots	\vdots	\vdots
s^1	z_0	\vdots	\vdots	\vdots	\vdots	\vdots
s^0	z_1	\vdots	\vdots	\vdots	\vdots	\vdots

$$\begin{aligned} b_0 &= \frac{-1}{a_1} \begin{vmatrix} a_0 & a_2 \\ a_1 & a_3 \end{vmatrix}, & b_2 &= \frac{-1}{a_1} \begin{vmatrix} a_0 & a_4 \\ a_1 & a_5 \end{vmatrix}, & b_4 &= \frac{-1}{a_1} \begin{vmatrix} a_0 & a_6 \\ a_1 & a_7 \end{vmatrix}, & \dots \\ b_1 &= \frac{-1}{b_0} \begin{vmatrix} a_1 & a_3 \\ b_0 & b_2 \end{vmatrix}, & b_3 &= \frac{-1}{b_0} \begin{vmatrix} a_1 & a_5 \\ b_0 & b_4 \end{vmatrix}, & b_5 &= \frac{-1}{b_0} \begin{vmatrix} a_1 & a_7 \\ b_0 & b_6 \end{vmatrix}, & \dots \\ b_2 &= \frac{-1}{b_1} \begin{vmatrix} b_0 & b_2 \\ b_1 & b_3 \end{vmatrix}, & b_4 &= \frac{-1}{b_1} \begin{vmatrix} b_0 & b_4 \\ b_1 & b_5 \end{vmatrix}, & b_6 &= \frac{-1}{b_1} \begin{vmatrix} b_0 & b_6 \\ b_1 & b_7 \end{vmatrix}, & \dots \\ & \vdots & & & & & \\ z_1 &= a_n & & & & & \end{aligned}$$

(5/8)

5 Taajuusvaste

Taajuusfunktio:

$$F(\omega) = G(j\omega) = \operatorname{Re}\{G(j\omega)\} + j \cdot \operatorname{Im}\{G(j\omega)\} \Rightarrow z = R + j \cdot X$$

$$\begin{cases} |z| = \sqrt{R^2 + X^2} \\ \angle\{z\} = \arctan(X/R) + n\pi \quad (n=0 \text{ jos } R > 0, n=1 \text{ jos } R < 0) \end{cases}$$

Amplitudisuhde A ja vaihe-ero φ :

$$A = \frac{A_y}{A_x} = |G(j\omega)| = \sqrt{\operatorname{Re}\{G(j\omega)\}^2 + \operatorname{Im}\{G(j\omega)\}^2}$$

$$\varphi = \angle\{G(j\omega)\} = \arctan(\operatorname{Im}\{G(j\omega)\} / \operatorname{Re}\{G(j\omega)\}) + n\pi$$



$(n=0 \text{ jos } \operatorname{Re}\{G(j\omega)\} > 0, n=1 \text{ jos } \operatorname{Re}\{G(j\omega)\} < 0)$

Eulerin kaava:

$$e^{Aj} = \cos(A) + \sin(A)j$$

$$e^{-Bj} = \cos(B) - \sin(B)j$$

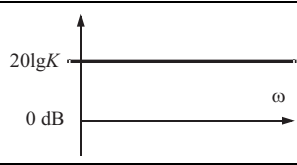
5.1 Boden diagrammin peruskomponentit

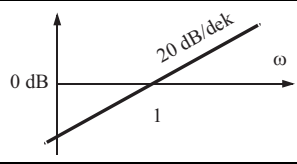
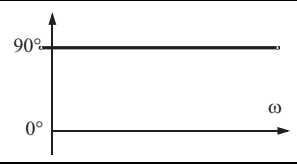
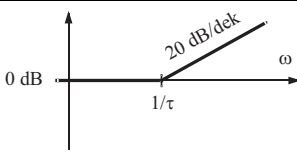
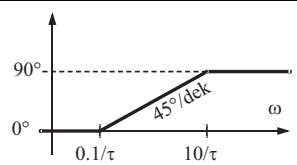
$G(j\omega)$	$20 \cdot \lg G(j\omega) \text{ dB}$	$\angle\{G(j\omega)\}$
K ($K \geq 0$)		
s		
$\tau s + 1$ ($\tau > 0$)		

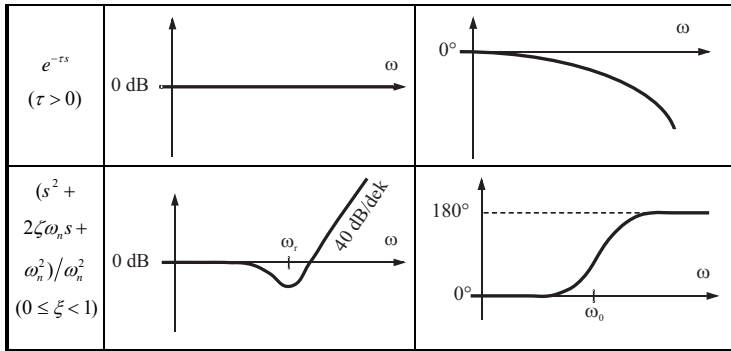

$$\omega_r = \omega_n \sqrt{1 - 2\zeta^2}$$

Mikäli piirrettävä tekijä on nimittäjässä, ovat vahvistus- ja vaihekäyrät peilikuvia yllä esitetystä käyrästä nollatasoon suhteen.

6 Säätimet

6.1 PID-säädin

$$\begin{cases} u(t) = K_p \left(e(t) + \frac{1}{T_I} \int_0^t e(\tau) d\tau + T_D \frac{de(t)}{dt} \right) \\ u(t) = K_p e(t) + K_I \int_0^t e(\tau) d\tau + K_D \frac{de(t)}{dt} \\ \begin{cases} K_I = \frac{K_p}{T_I} \\ K_D = K_p T_D \end{cases} \end{cases}$$

6.2 Vaiheenjohtopiiri

$$G_{lead}(s) = K \frac{\frac{1}{\omega_b} s + 1}{\frac{1}{k\omega_b} s + 1}$$

$$\omega_m = \sqrt{k} \omega_b$$

$$\sin(\phi_m) = \frac{k-1}{k+1}$$

6.3 Vaihenjättöpiiri

$$G_{lag}(s) = K \frac{\frac{1}{k\omega_b} s + 1}{\frac{1}{\omega_b} s + 1}$$

6.4 Vaiheenjohtopiiri

$$G_{lead-lag}(s) = K \frac{\frac{1}{\omega_1} s + 1}{\frac{1}{k\omega_1} s + 1} \frac{\frac{1}{k_2\omega_2} s + 1}{\frac{1}{\omega_2} s + 1}$$

7 Testifunktioita

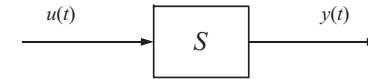



Testifunktio	Aikataso	Laplace-muunnos
yksikköimpulssifunktio $u(t)$ 	$u(t) = \delta(t) = \begin{cases} \infty, & t = 0_+ \\ 0, & \text{muulloin} \end{cases}$ $\int_{-\infty}^{\infty} u(t) dt = 1$	$U(s) = 1$
yksikkökäskelfunktio $u(t)$ 	$u(t) = \begin{cases} 0, & t \leq 0 \\ 1, & t > 0 \end{cases}$	$U(s) = \frac{1}{s}$
yksikköpengerfunktio $u(t)$ 	$u(t) = \begin{cases} 0, & t \leq 0 \\ t, & t > 0 \end{cases}$	$U(s) = \frac{1}{s^2}$

8 Yksinkertaisten systeemien impulssi- ja askelvasteita

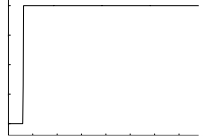
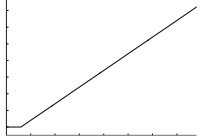
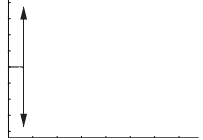
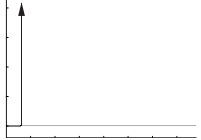
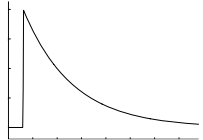
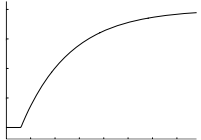
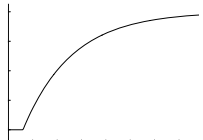
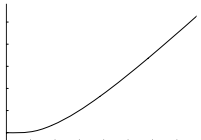
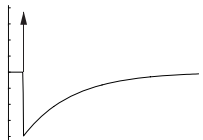
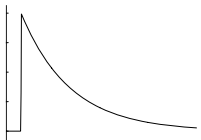
$$\tau > 0, K > 0, 0 < \zeta < 1, \omega_n \neq 0$$

	Siirtofunktio	Impulssivaste	Askelvaste
1.	$\frac{K}{s}$		
2.	Ks		
3.	$\frac{K}{\tau s + 1}$		
4.	$\frac{K}{s(\tau s + 1)}$		
5.	$\frac{Ks}{\tau s + 1}$		

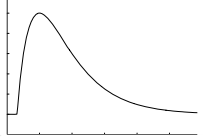
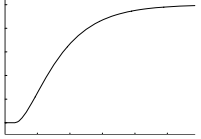
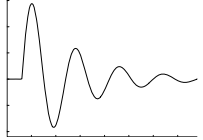
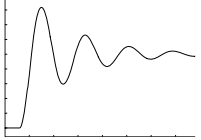
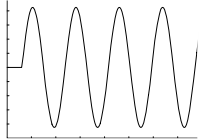
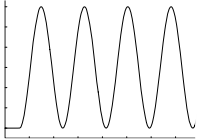
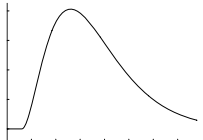
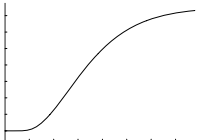
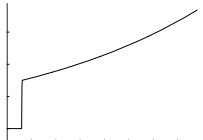
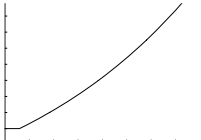
(7/8)

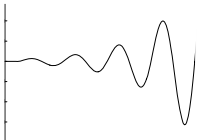
	Siirtofunktio	Impulssivaste	Askelvaste
6.	$\frac{K}{(\tau_1 s + 1)(\tau_2 s + 1)}$		
7.	$\frac{K\omega_n^2}{s^2 + 2\zeta\omega_n s + \omega_n^2}$		
8.	$\frac{K\omega_n^2}{s^2 + \omega_n^2}$		
9.	$\frac{K}{(\tau_1 s + 1)(\tau_2 s + 1)(\tau_3 s + 1)}$		
10.	$\frac{K}{\tau s - 1}$		
11.	$\frac{K\omega_n^2}{s^2 - 2\zeta\omega_n s + \omega_n^2}$		

9 Tekijöihin jako

$$Y(s) = \frac{P(s)}{(s-r_1)(s-r_2)\dots(s-r_n)} = \frac{K_1}{(s-r_1)} + \frac{K_2}{(s-r_2)} + \dots + \frac{K_n}{(s-r_n)}, \quad r_i \neq r_j, \quad i \neq j$$

$$Y(s) = \frac{P(s)}{(s-r)^q (s-r_1)\dots(s-r_n)} \\ = \frac{C_q}{(s-r)^q} + \frac{C_{q-1}}{(s-r)^{q-1}} + \dots + \frac{C_1}{(s-r)} + \frac{K_1}{(s-r_1)} + \dots + \frac{K_n}{(s-r_n)}$$

Heavisiden menetelmä

$$K_i = \lim_{s \rightarrow r_i} \left\{ (s-r_i) \cdot Y(s) \right\} \quad i = 1, 2, \dots, n$$

$$C_q = \lim_{s \rightarrow r} \left\{ (s-r)^q \cdot Y(s) \right\}$$

$$C_{q-1} = \lim_{s \rightarrow r} \left\{ \frac{d}{ds} \left[(s-r)^q \cdot Y(s) \right] \right\}$$

⋮

$$C_{q-k} = \lim_{s \rightarrow r} \left\{ \frac{1}{k!} \frac{d^k}{ds^k} \left[(s-r)^q \cdot Y(s) \right] \right\}$$

10 Laplace-muunnos

Määritelmä: $F(s) = L\{f(t)\} = \int_0^{\infty} f(t)e^{-st} dt$

10.1 Laplace-muunnoksen teoreemoja

Laplace-muunnos	Ajan funktio
$F(s)$	$f(t)$
$C_1 F_1(s) + C_2 F_2(s)$	$C_1 f_1(t) + C_2 f_2(t)$
$F(s+a)$	$e^{-at} f(t)$
$e^{-as} F(s)$	$\begin{cases} 0, & t \leq a \\ f(t-a), & t > a \end{cases}$
$\frac{1}{a} F\left(\frac{s}{a}\right)$	$f(at)$
$F_1(s)F_2(s)$	$\int_0^t f_1(\tau)f_2(t-\tau)d\tau$
$sF(s) - f(0)$	$f'(t)$
$s^n F(s) - [s^{n-1}f(0) + \dots + f^{(n-1)}(0)]$	$f^{(n)}(t)$

10.2 Laplace-muunnos ja aikavasteita

Laplace-muunnos	Ajan funktio
1	$\delta(t)$
$1/s$	1
$1/s^2$	t
$1/s^{n+1}$	$t^n / n!$
$\frac{1}{s+a}$	e^{-at}
$\frac{1}{(s+a)^{n+1}}$	$\frac{t^n e^{-at}}{n!}$
$\frac{1}{s(s+a)}$	$\frac{1}{a}(1 - e^{-at})$
$\frac{1}{(s+a)(s+b)}$	$\frac{1}{a-b}(e^{-bt} - e^{-at})$
$\frac{1}{s(s+a)(s+b)}$	$\frac{1}{ab} + \frac{1}{ab(b-a)}(ae^{-bt} - be^{-at})$
$\frac{a}{s^2 + a^2}$	$\sin(at)$
$\frac{s}{s^2 + a^2}$	$\cos(at)$
$\frac{a}{(s+b)^2 + a^2}$	$e^{-bt} \sin(at)$
$\frac{s+b}{(s+b)^2 + a^2}$	$e^{-bt} \cos(at)$
$\frac{s+a}{s+b}$	$\delta(t) + (a-b)e^{-bt}$

Mikäli $f(t)$:n ja $F(s)$:n raja-arvot ovat olemassa, niille pätee:

$$\lim_{s \rightarrow 0} \{sF(s)\} = \lim_{t \rightarrow \infty} \{f(t)\} \quad \lim_{s \rightarrow \infty} \{sF(s)\} = \lim_{t \rightarrow 0} \{f(t)\}$$