

# Groundwater, its treatment and protection

**Harri Mattila, 2021**

**Principal Research Scientist at Häme University of Applied Sciences, HAMK ([www.hamk.fi](http://www.hamk.fi))**

**D.Tech. (civil engineering)**

**Associate Professor at TUNI (decentralized water services)**

# General

- **Groundwater forms only 0,53 % of all water resources (worldwide).**
- **In Finland, more than 2/3 of all raw water is groundwater or artificial groundwater**
- **Advantages of groundwater when compared to surface water:**
  - **No need for disinfection (in normal situations)**
  - **Temperature is rather constant (and low)**
  - **Little or no chemicals involved in treatment**

# The hydrological cycle

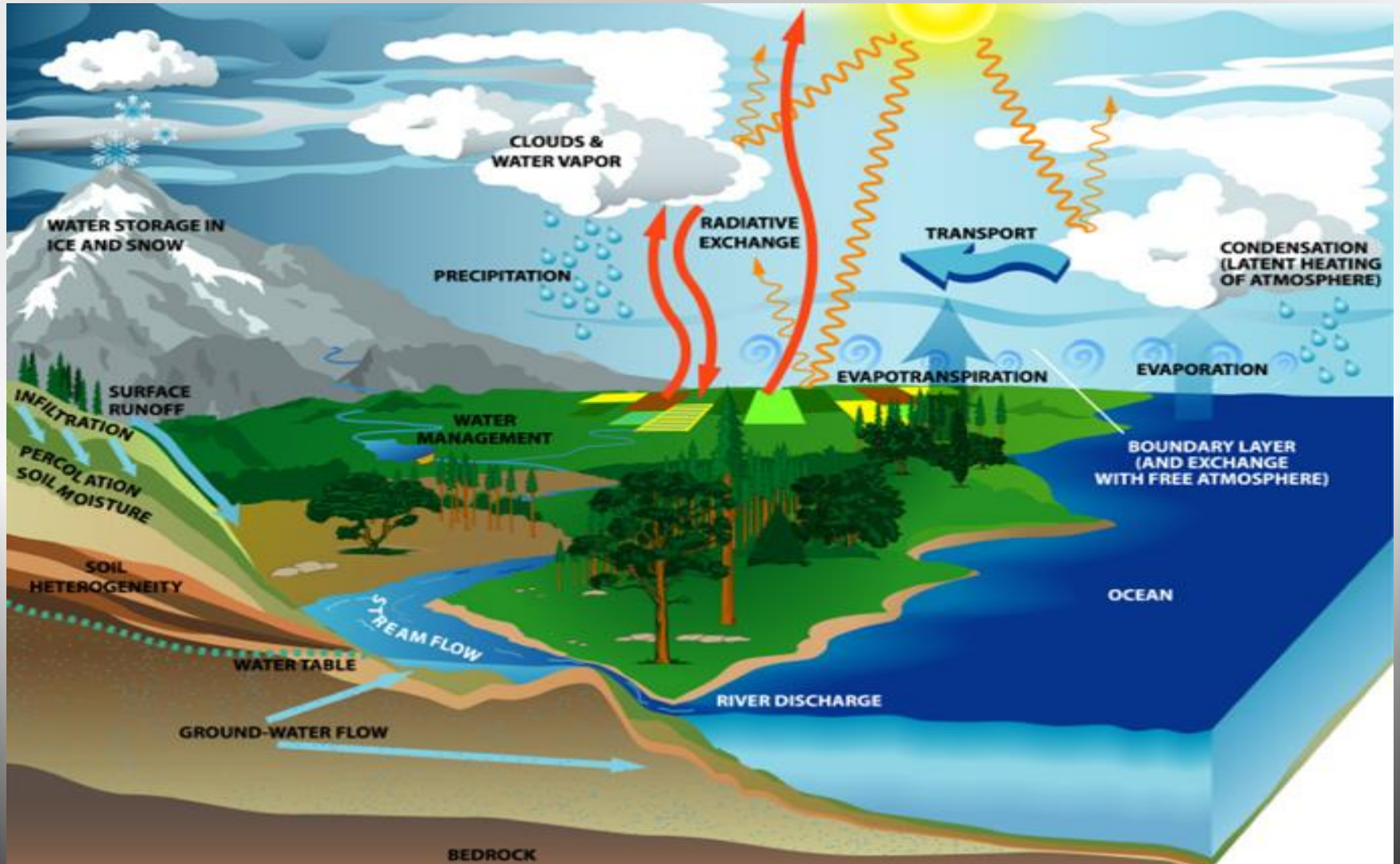

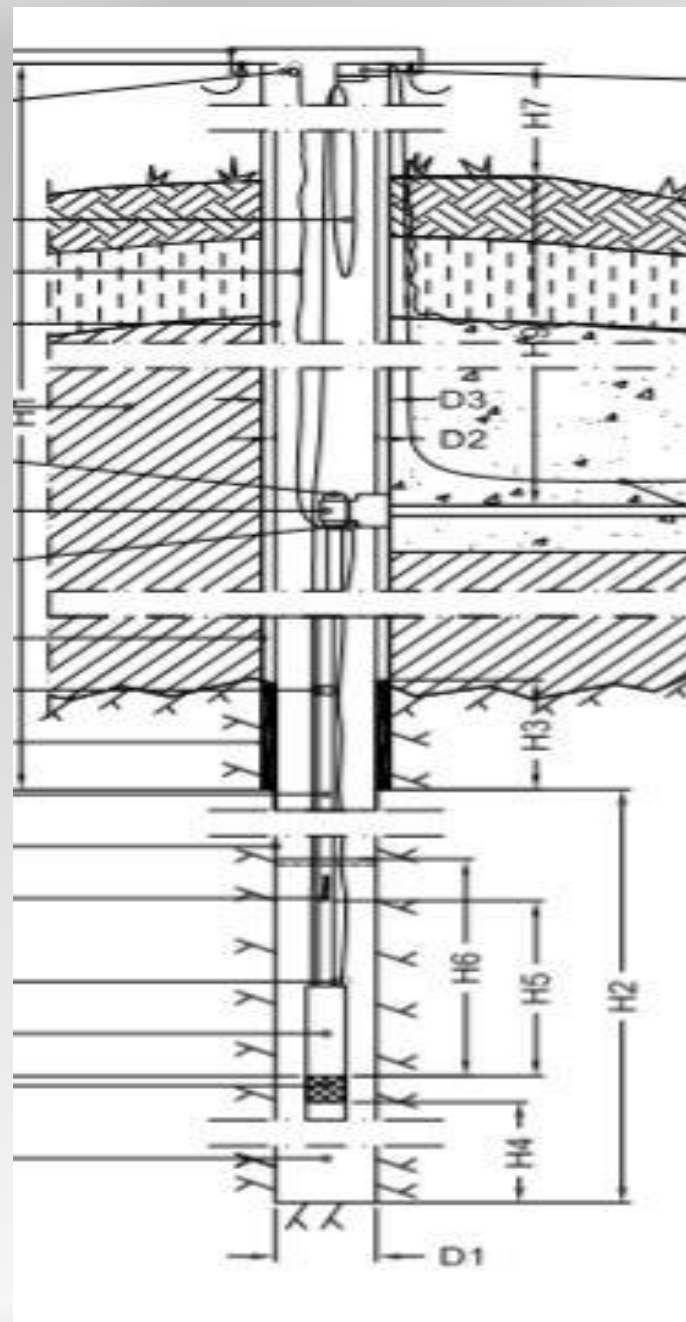
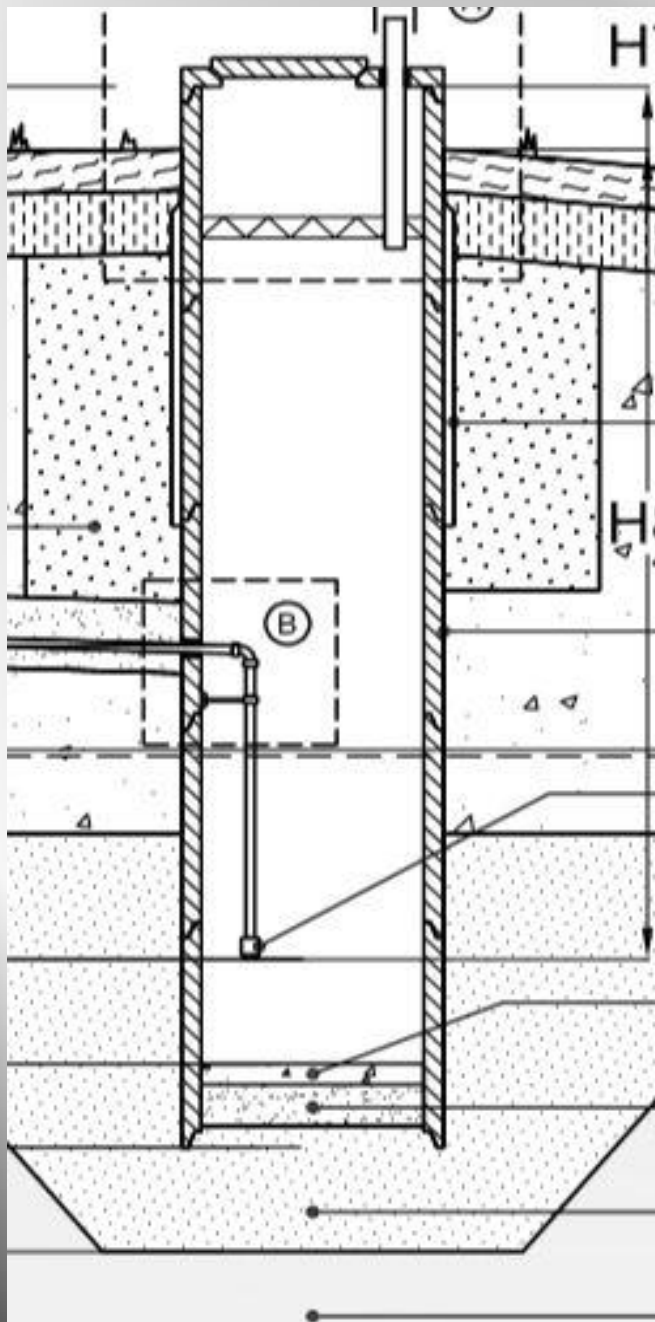

# Observation tube (well)

- Usually PVC pipe
- DN > 50 mm
- Screen in the depth of the groundwater layer

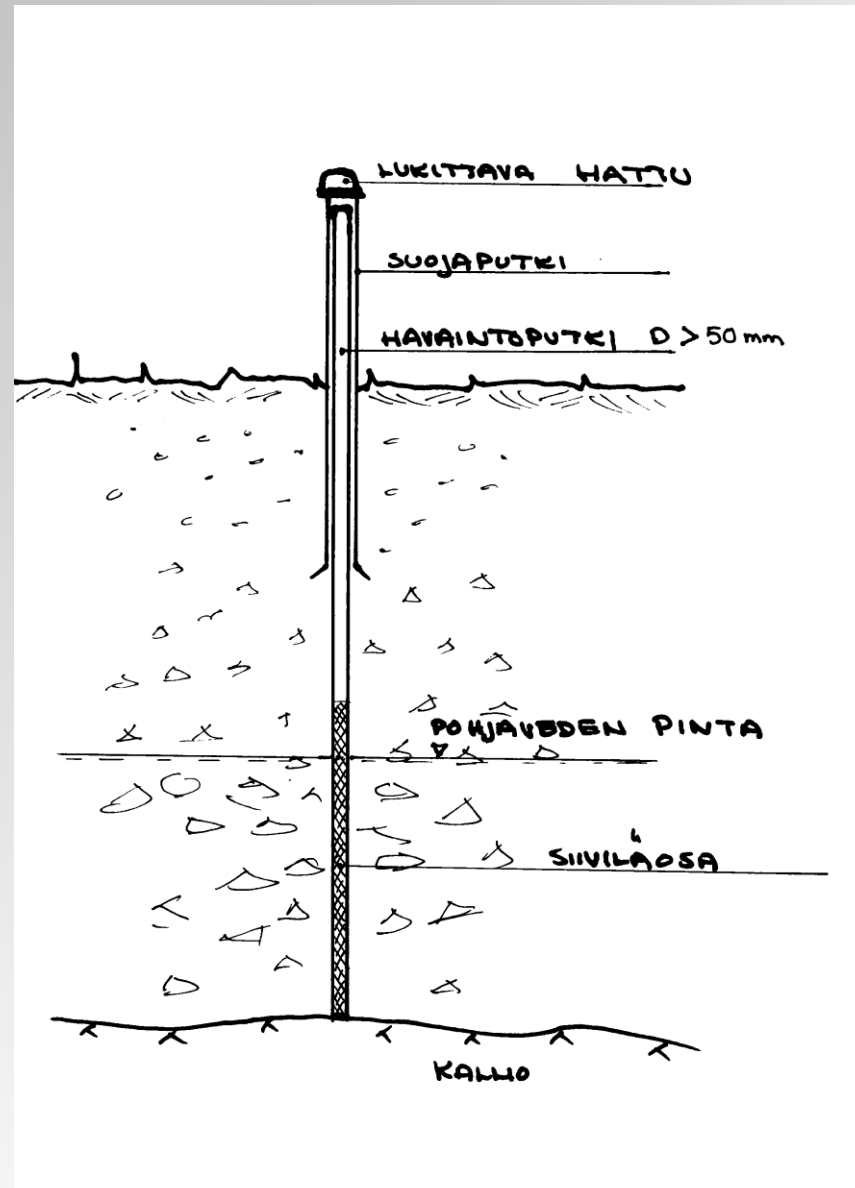

# An example of groundwater depth variations (Tuusula, Finland)

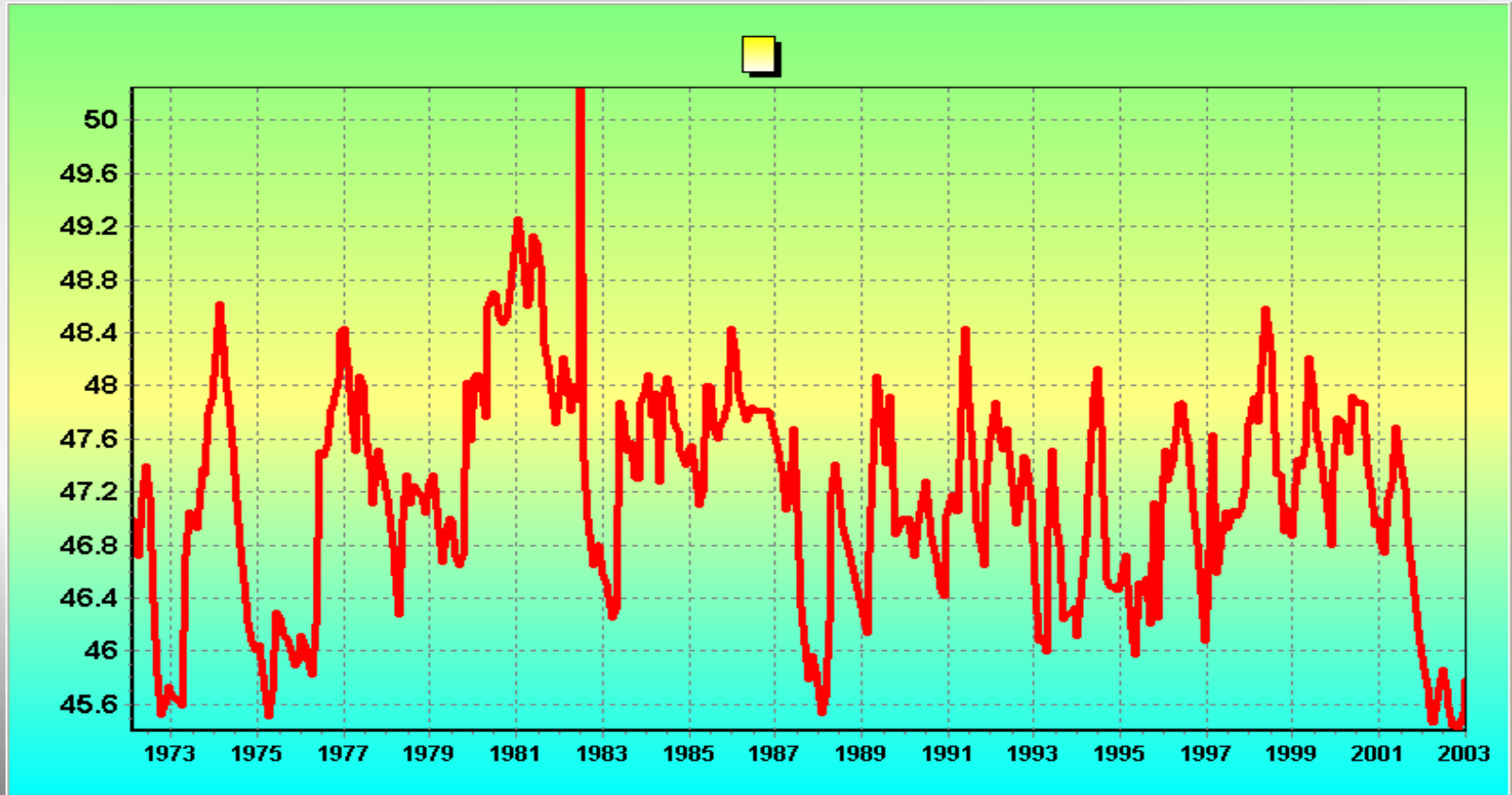

# The need for groundwater treatment

- **optimum situation: no treatment**
- **most common reason is prevention of corrosion**
- **Fe or Mn (in Finland)**
- **organic material**
- **fluoride**
- **salts**
- **radon**
- **arsenic**





# pH -value

- **Depends on soil around the groundwater well**
- **Sometimes rain water can be acidic**
- **pH of groundwater in Finland is normally between 5 - 7**

# Nitrate compounds

- ammonium, nitrate, nitrite, nitrogen
- Very rarely in Finnish groundwaters
- Usually means pollution by agriculture or industry
- Sometimes also because of wastewater in groundwater!

# Sulfate

- **Can be diluted in groundwater for example from minerals rich of sulphur because of high pH.**
- **Important factor in corrosion**
- **limit 50 mg/l**

# Iron and manganese

- **Most common problems in groundwater (specially in Finalnd)**
- **No health hazard – technical and/or aesthetical problems**
- **Fe < 0,2 mg/l, Mn < 0,05 mg/l**
- **Causing also sedimentation in networks and that's why harmful**

# Chloride

- **Normally because of nearby sea but also because of deicing in winter**
- **In nature < 10 mg/l, taste limit 200 – 300 mg/l, recommended maximum 250 mg/l, target 25 mg/l**
- **Very important factor in corrosion**

# Hardnes

- **Ca- ja Mg –salts**
- **1 mmol/l = 5,6 ° dH**
- **Should be 3 – 5 ° dH**
- **The most interesting parameter to customers due to washing machines**
- **sometimes high also in Finland, even >10**

# Aluminium

- **Can be diluted from from the soil (like Fe and Mn), specially when the soil in acidic**
- **The maximum limit allowed 0,2 mg/l**

# Arsenic

- **carcinogenic, max allowed 0,01 mg/l**
- **Mainly in deep boreholes**
- **In Finland about 7% of all the deep wells are contaminated**



# Boron

- **Max allowed 1,0 mg/l**
- **Is indicating pollution by wastewater**
- **Appears very seldom**

# Fluoride

- **WHO: max allowed 1,5 mg/l (note, drinking water should have 0,5 mg/l)**
- **Defluoridation is considered as an expensive task => 1. change the source if possible, 2. dilute water with another one with less flouride, 3. treatment**

# Copper

- **Max allowed 2,0 mg/l ( an average / week)**
- **Rather seldom in groundwater**
- **Mainly because of corrosion in pipelines (green colour on basins)**

# Bacteria

- ▣ **E.coli is the most important indicator**

# Viruses

- **Very difficult to analyze => difficult to separate/destroy from water**

# Dilutants

- **Altogether about 70 compounds**
- **Hydrocarbons, alcohols, aethers, esters, aldehydes, ketones**

# MTBE, TAME

- **Additives in petrol**
- **Are diluted very easily in water => the first compounds found in case of pollution**
- **Easy to detect by smell and taste (0,03 mg/l)**

# Pesticides

- **Hundreds of compounds**
- **Max allowed 0,0005 mg/l (total)**
- **The smallest amounts which can be detected are normally 0,00001 – 0,00002 mg/l**



# Radioactivity

- **Mostly in deep wells (in the rock)**
  - **No smell, no colour, no taste !**
  - **Radon is the most common one in groundwater**
  - **Max allowed 1000 Bq/l)**
- => 1. new water source, 2. treatment (aeration, active carbon filtration)**

# Uranium

- **Lack of knowledge concerning health effects**
- **Earlier max by WHO 0,15 mg/l, today 0,002 mg/l**

# Corrosion

- **pH > 7,5**
- **alkalinity > 0,6 mmol/l**
- **calcium > 10 mg/l**
- **oxygen > 2 mg/l**

# Maps and aerial photographs

- **Swamps, springs, ditches, etc.**
- **Humidity changes out of photgraphs**
- **Old maps might give valuable information**

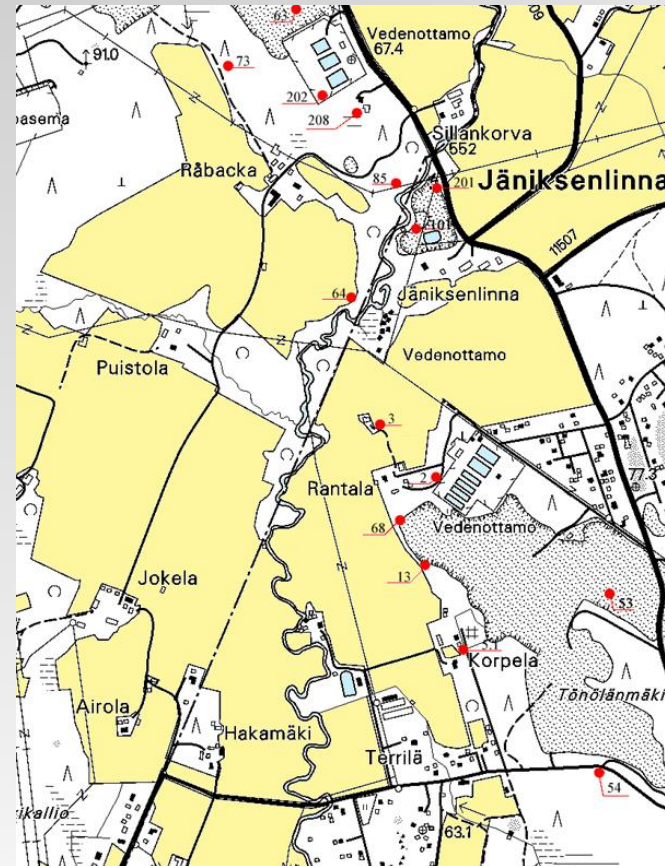

# Geophysical methods

- ▣ **Seismic sounding**
- ▣ **Electrical probing (resistance)**

# Drillings

- **Manually**
- **Machinery**



# Iron and manganese

- **Most common quality problem with ground waters**
- **Coagulation happens immediately with oxygen**
- **Iron can be removed also biologically**

# Removal of Fe and Mg

- **In small scales**
  - aeration
  - sand filtration
  - ion exchange processes
- **Lime stone filtration**
- **Slow sand filtration**



# Slow sand filtration

- **Water is filtered slowly through a sand layer**
- **Surface load 0,05 – 0,2 m/h**
- **Water per one 1 m<sup>2</sup>: 50 – 200 l/h**
- **Iron content max 1mg/l**
- **Pretreatment could be done by a filter containing crushed stone**

# Sand filtration

- ❑ **Aeration needed almost always**
- ❑ **Dissolved iron is oxidized => can be filtered out of water**
- ❑ **Surface load normally 4 – 5 m/h**
- ❑ **Small filters require backwashing more often**
- ❑ **Might be expensive ?**

# UV disinfection

- **Generally, ground water is microbiologically clean**
- **Sometimes we have experienced pollution**
- **UV-disinfection is applicable method for ground waters (no turbidity nor colour)**
- **UV-disinfection is not affecting the taste of water unlike chlorination**
  
- **Note: in Finland, all water utilities must prepare themselves for disinfection**

# Ground water protection !



Raati

