



Aalto University  
School of Engineering

# MEC-E1004 Principles of Naval Architecture

*Lecture 4 – Hull form*

# Learning points !

- After the lecture, you will be able to list and explain :
  - *The basic hull form related terminology*
  - *The factors that need to be considered when determining the form of a ship's hull*
  - *How you can apply the above knowledge to shape your ship's hull*

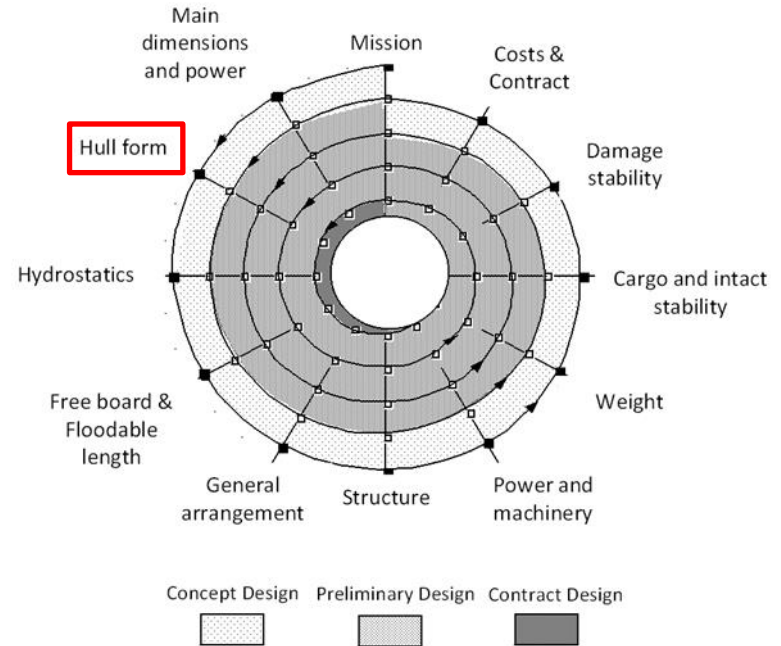

# Assignment 4 – Hull form

- Define your ship's hull form based on her main dimensions
  - *Define the sectional area curve and justify/discuss its features (e.g. length of the parallel mid-body, longitudinal center of buoyancy)*
  - *Define and motivate the form of the ship's bow, stern, and mid-ship areas*
  - *Make use of statistics, regression equations, reference ships, etc.*
  - *Create a draft sketch of the hull form (draft lines drawing) using the hull form.xls provided.*
  - *Use of MAXSURF CAD system to generate the hull form is optional. Teams that will become familiar with this software and generate a professional lines plan by the date of submission of Assignment 5 will be given extra marks.*

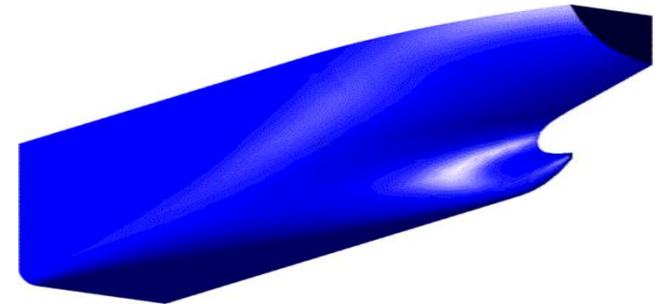
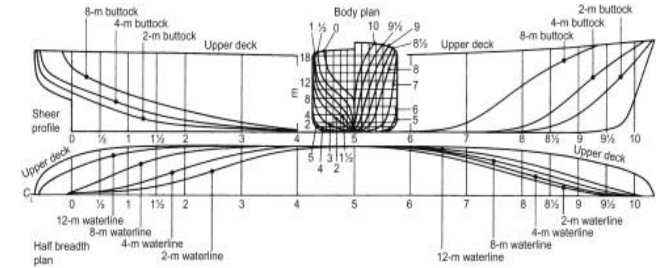

# Key Terminology (Revision from last time)

**Longitudinal prismatic coefficient  $C_P$** , is the ratio of actual underbody volume to the volume of a prism having a length equal to the DWL, and a section equal to the boat's maximum sectional area

Provides an indication of the distribution of displacement

$$C_P = \frac{\nabla}{L A_M}$$

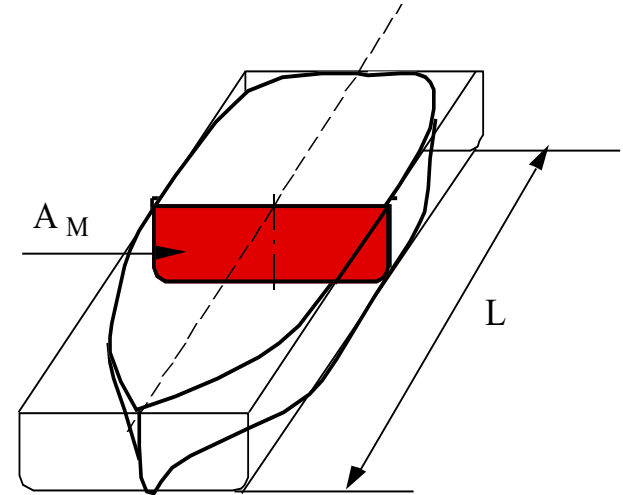

# Key Terminology (Revision from last time)

**Midship Section Coefficient  $C_M$**  is the ratio between the actual underwater area of a midship section and that of a rectangle of the same depth and width.

It very much depends on the bilge radius. For cargo ships, its value is 0.75-0.99

$$C_M = \frac{A_M}{B T}$$

- $C_M$  typically decreases with the block coefficient  $C_B$
- Also the main ratio  $L/B$  has a relatively large influence on  $C_M$

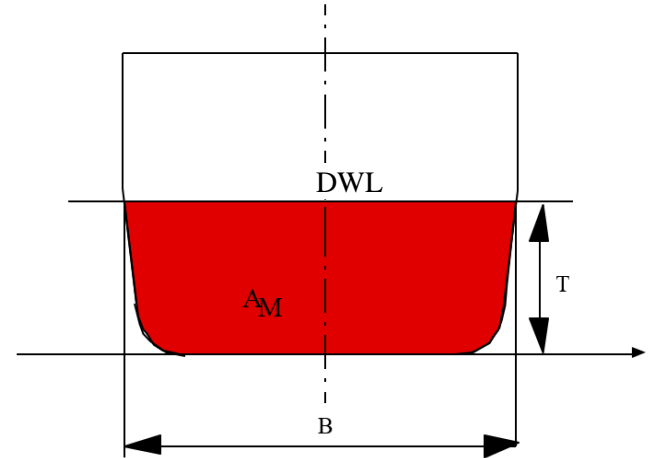

# Key Terminology (Revision from last time)

**Waterplane Coefficient  $C_{wp}$**  is the ratio between the area of the waterplane and that of a rectangle of the same length and breadth.

$$C_{WP} = \frac{A_{WP}}{L B}$$

It is calculated for different drafts and typically ranges between 0,65 and 0,95 depending on the parallel extends of the mid-ship section and the sharpness of the bow and stern sections

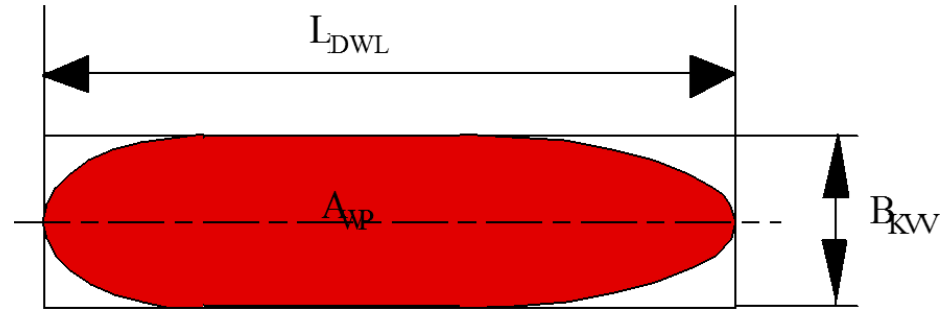

# Interplay of $C_M$ and $C_P$ with $C_B$

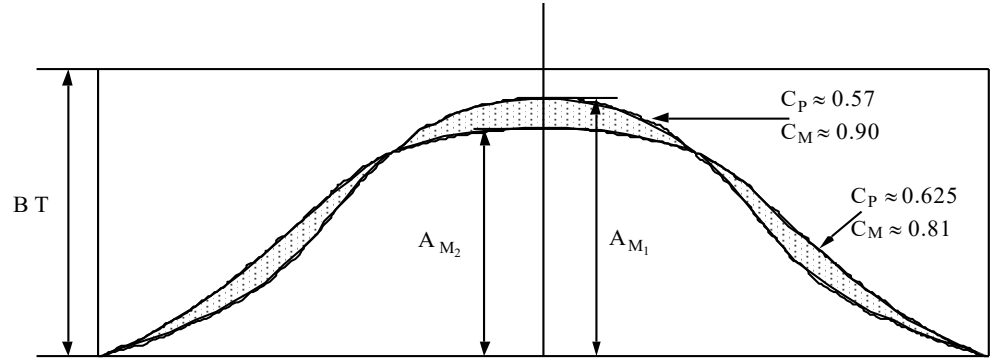
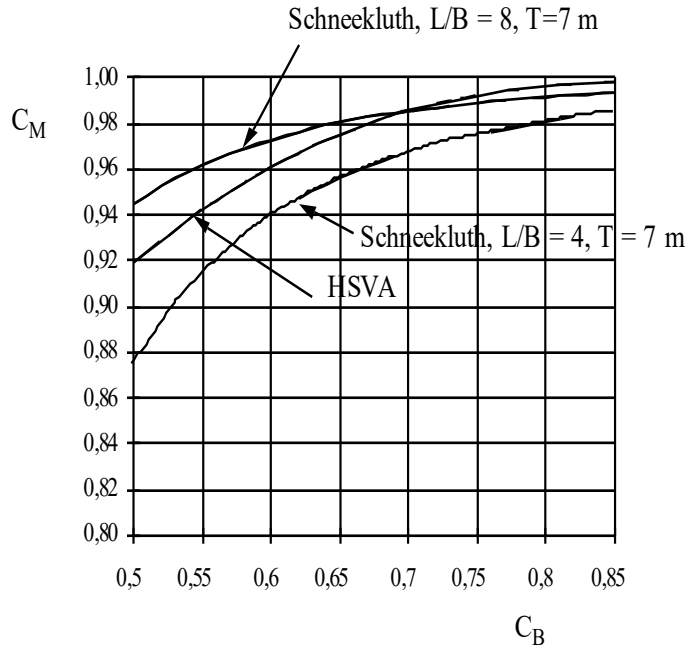

## Sectional Area Curve variation

**Kerlen (1970)**

$$C_M = 1.006 - 0.0056 \cdot C_B^{-3.56}$$

**HSVA**

$$C_M = \frac{1}{1 + (1 - C_B)^{3.5}}$$

# The Froude No ( $F_n$ ) (Revision from Lecture 1)

- An important speed measure as it relates speed and length
- Different ship types have different characteristic speed ranges, determined both by technological and economic factors

Ship type	Froude number range
Crude oil tanker	0.12 - 0.16
Product tanker	0.16 - 0.19
Bulk carrier	0.15 - 0.19
Container ship	0.24 - 0.27
Passenger ship	0.24 - 0.35

Examples of characteristic speed ranges for different types of ships

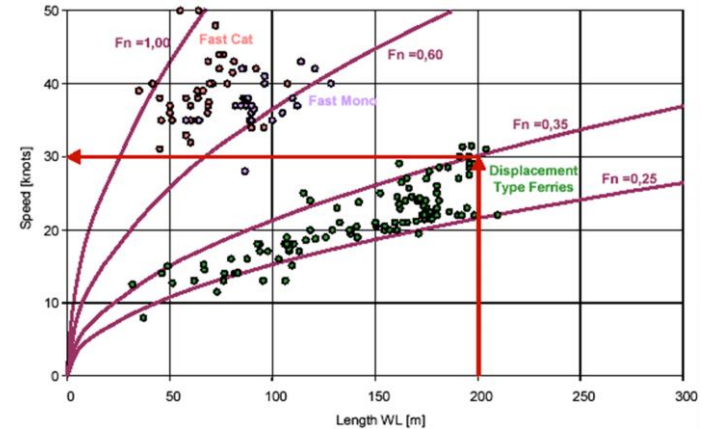

Adverse and favorable regions of Froude numbers in terms of wave resistance for normal ships

$$F_n = V / \sqrt{g \cdot L_{PP}}$$

Adverse regions (tuning) 0.45–0.50, 0.29–0.31, 0.23

Favorable regions (attenuation) 0.33–0.36, 0.25, 0.21



# Example trim diagram (Revision from last time)

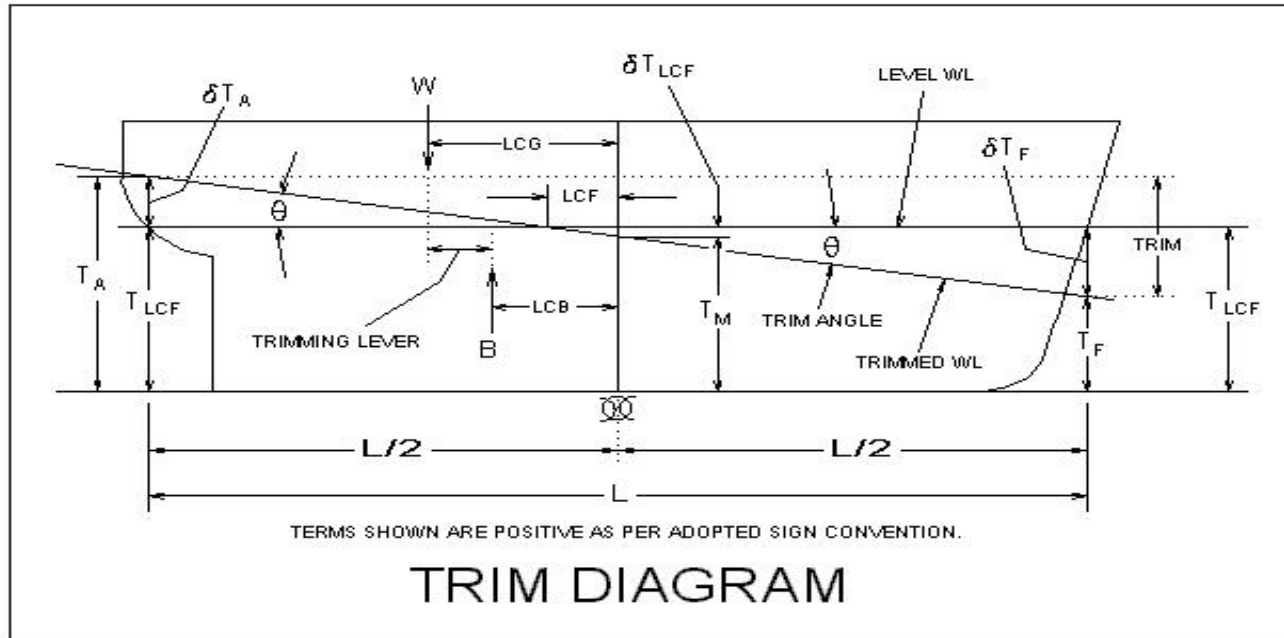

# Ship Stability & Trim - Definitions

- ❑ **B** is the Buoyancy Force provided by the vessel with level trim. Usually obtained from a "Curves of Form" plot. In this procedure **B** is numerically equal to the vessel's displacement (i. e.  $\mathbf{B} = \Delta$ ).
- ❑ **W** is the total weight applied to the vessel. Usually obtained from a "Weights and Moments" analysis.
- ❑ **L** is the length between the forward and after draft marks
- ❑ **LCG** is the Longitudinal Center of Gravity location, normally obtained from a "Weights and Moments" analysis.
- ❑ **LCB** is the Longitudinal Center of Buoyancy location, usually obtained from a "Curves of Form" plot.
- ❑ **LCF** is the Longitudinal Center of Floatation, normally obtained from a "Curves of Form" plot.
- ❑  $T_A$  is the draft and the Aft Draft marks
- ❑  $T_F$  is the draft at the Forward Draft marks
- ❑  $T_M$  is the Draft Amidships, located midway between forward and aft draft marks
- ❑  $T_{LCF}$  is the draft located at the Longitudinal Center of Floatation.

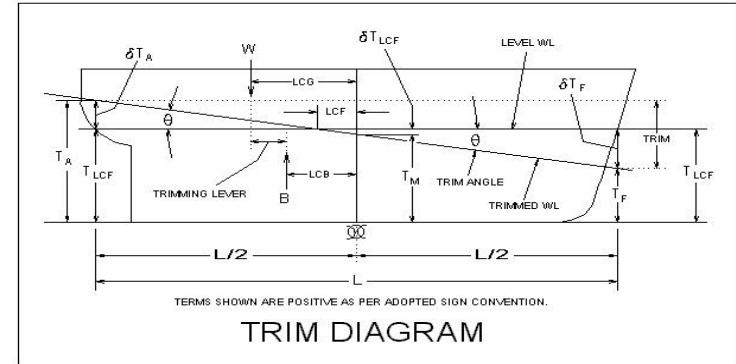

## Typical Sign conventions

- Distances Aft of Amidships are Positive, applies to LCG and LCB
- Trim by the stern is defined as Positive
- Trim Moment causing trim by the stern is Positive
- Trim Lever that causes trim by the stern is Positive

# Lines plan (Overview 1)

Example lines plan for MS Hjaltland



© Paula Gent  
MarineTraffic.com

Loa	=	125.00	m
Lwl	=	124.97	m
Lpp	=	119.00	m
Bmax	=	19.50	m
Bwl	=	19.50	m
Tdwl	=	5.30	m
Lwl/Bwl	=	6.41	
Lwl/Tdwl	=	23.58	
Bwl/Tdwl	=	3.68	

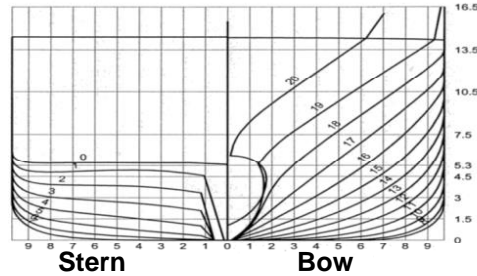

Disv	=	7072	m <sup>3</sup>
S	=	2631	m <sup>2</sup>
Cb	=	0.5750	
Cm	=	0.9657	
Cp	=	0.5955	
Cwp	=	0.8201	
LCB	=	-3.87	%
VCB	=	3.08	m
KMT	=	10.51	m

Body plan

Frames / Buttocks / Verticals

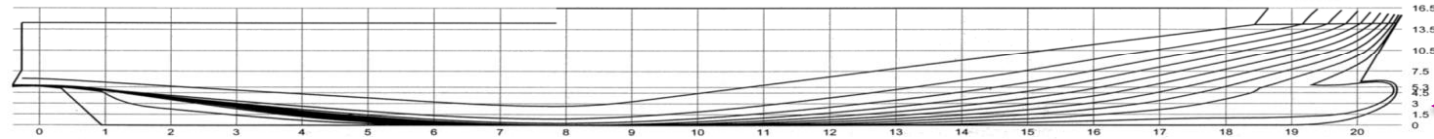

Waterlines

Stations

Profile plan / Sheer plan

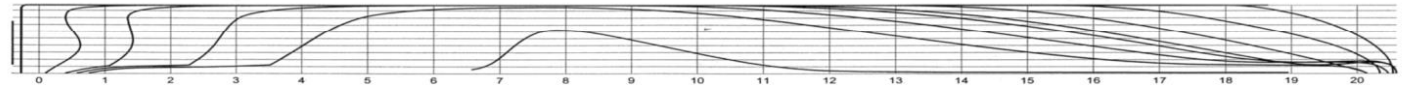

Half-breath plan / Waterlines plan

# Lines plan (Overview 2)

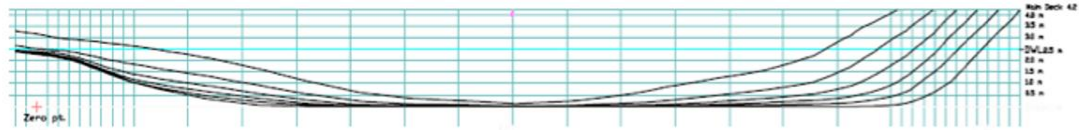

PROFILE

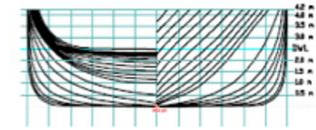

HALF-BREATH PLAN

Image credit marineinsight.com

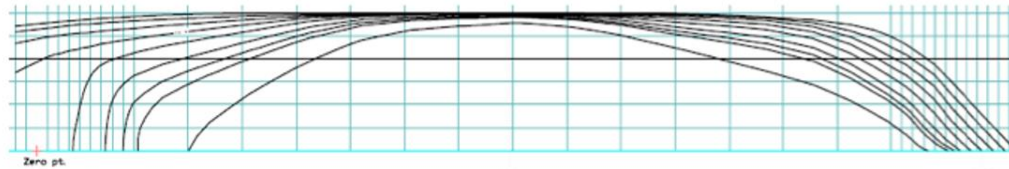

HALF-BREATH PLAN

- *A mono-hull ship is nearly always symmetric with respect to center plane*
  - ✓ Sufficient to present just one side of the hull
  - ✓ Necessary to multiply measurements taken from the lines drawing by two
- *By tradition the bow is rightwards*

# Lines plan - terminology

- A collection of lines at well defined positions that are used to define a hull form

- *Typically symmetric hull → enough to present one half of the hull*

- Projections of straight lines on to the hull surface from X-Y-Z planes

- **Body plan**

- Frames and waterlines show as straight lines and stations as curves

- **Profile / Sheer plan**

- Stations and Waterlines show as straight lines and Frames as curves

- **Half-breath / Waterlines plan**

- Stations and Frames show as straight lines and waterlines as curves

Example lines plan for MS Hjaltland

Loa	=	125.00	m
Lwl	=	124.97	m
Lpp	=	119.00	m
Bmax	=	19.50	m
Bwl	=	19.50	m
Tdwl	=	5.30	m
Lwl/Bwl	=	6.41	
Lwl/Tdwl	=	23.58	
Bwl/Tdwl	=	3.68	

Disv	=	7072	m3
S	=	2631	m2
Cb	=	0.5750	
Cm	=	0.9657	
Cp	=	0.5955	
Cwp	=	0.8201	
LCB	=	-3.87	%
VCB	=	3.08	m
KMT	=	10.51	m

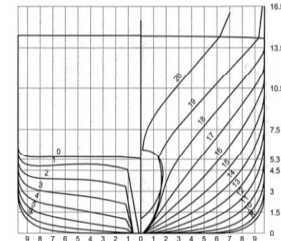

Stern Bow  
Body plan

Frames / Buttocks / Verticals

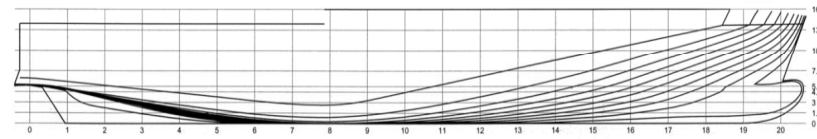

Stations Profile plan / Sheer plan

Waterlines

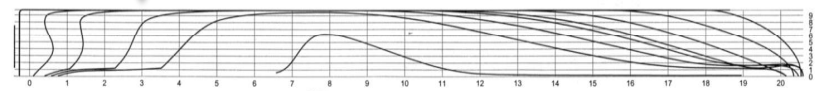

Half-breath plan / Waterlines plan

# Lines plan – station determination

- *The number of sectional planes in the lines drawing is based on the complexity of the hull form and on the accuracy requirements of the displacement calculations*
- *Usually 10 equally spaced stations are used in the first stage of the design*
- *Additional stations are used at the bow and stern because of the rapid longitudinal changes in the hull form in these areas*
- *The stations are numbered consecutively starting from the stern such that the station at the aft perpendicular is number '0'*
- *Station 10 is located at the fore perpendicular*

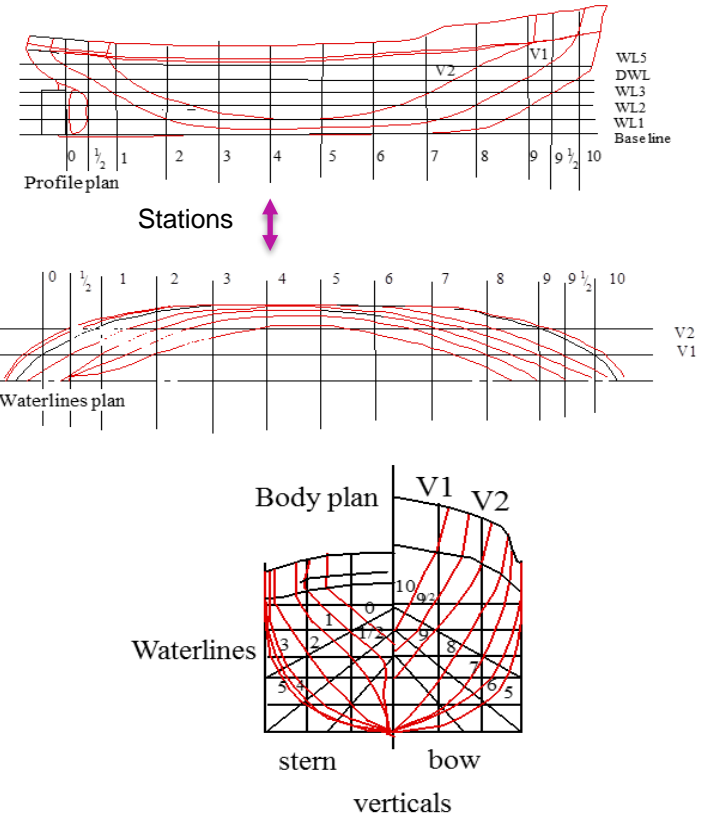

# Determination of hull form

*Question: Based on what input do you determine the form of a ship's hull? What factors do you need to consider?*

# Determination of the hull form – Starting point

- Main dimensions
  - *Length (L), Breadth (B), Draft (T), Depth (D), Block Coefficient ( $C_B$ ) are determined based on techno-economic considerations*
- Initial General Arrangement (GA)
  - *Help determine the location of large spaces*
- Design speed, type of propulsion device
- Mission
  - *e.g. constant or varying draft could affect the shape of the bulb*

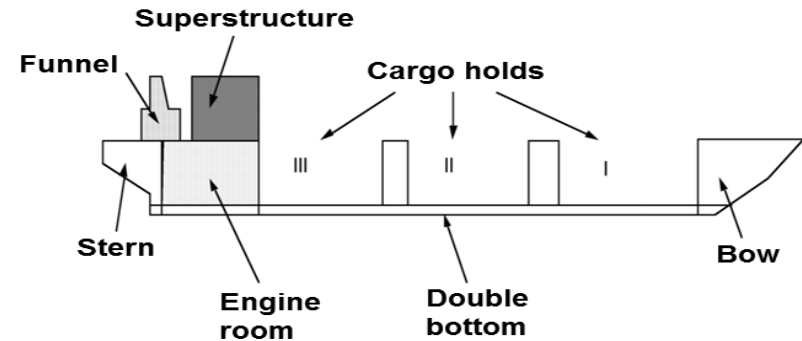



# Determination of hull shape - process

- Practical drawing process
  - *Both art and science*
    - ✓ Requires an eye for aesthetics
    - ✓ Requires care and precision
    - ✓ Appreciation of ship hydrodynamic performance
- Can be created
  - *from scratch*
  - *by using a reference design*
  - *by using existing lines series (e.g. Series 60)*

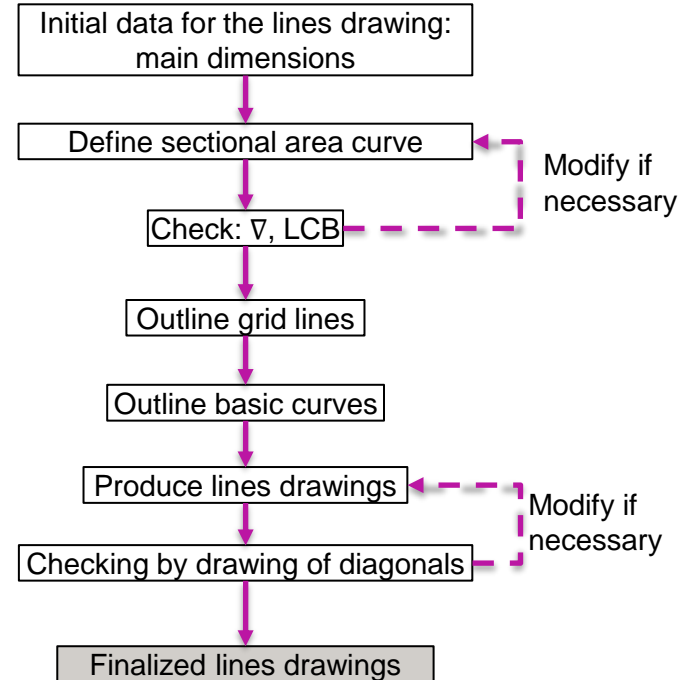

# Determination of hull form - Sectional area curve

- The Sectional Area Curve (SAC) represents the distribution of the displacement over the ship length
- Longitudinal positions on SAC curve represent sectional area values.
- The integral of the section area curve gives the volume of displacement needed to calculate the buoyancy and floating position of the ship.
  - *Buoyancy*  $\Delta = \rho g \nabla$ 
    - ✓ Fresh water has density 1,00 ton/m<sup>3</sup>, in Finnish coast it is 1,005 ton/ m<sup>3</sup> and at oceans it is 1,025 ton/ m<sup>3</sup>
- Center of this area gives the LCB.

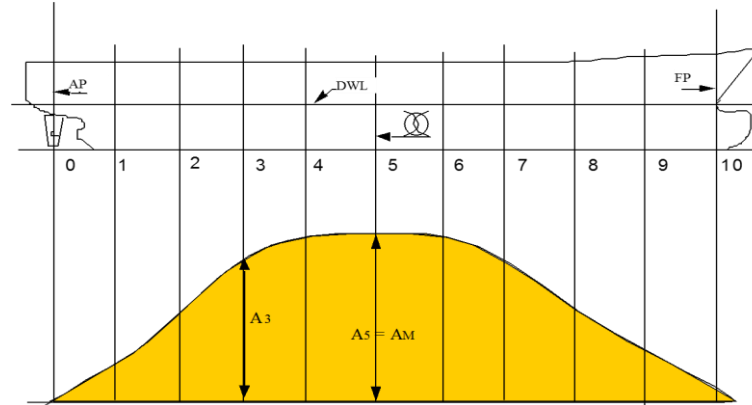

# Determination of hull form - Sectional area curve

- The curve is extended over the ship's length which is divided into three lengths namely :
  - ✓ the entrance length  $L_E$
  - ✓ the length of run  $L_R$
  - ✓ the length of the parallel middle body  $L_M$ .

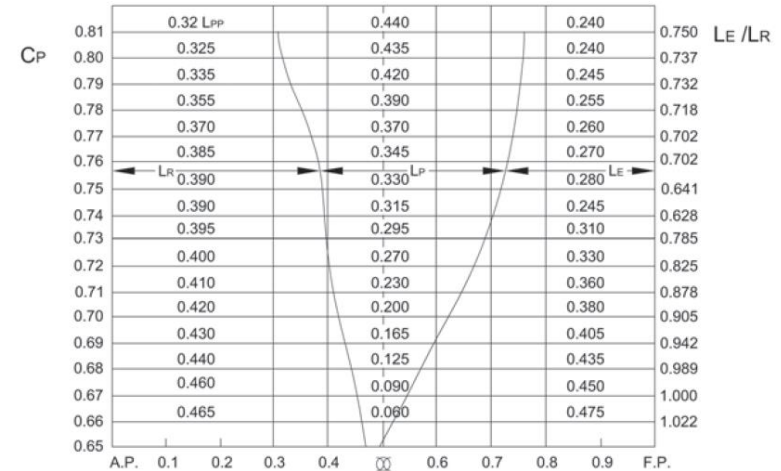
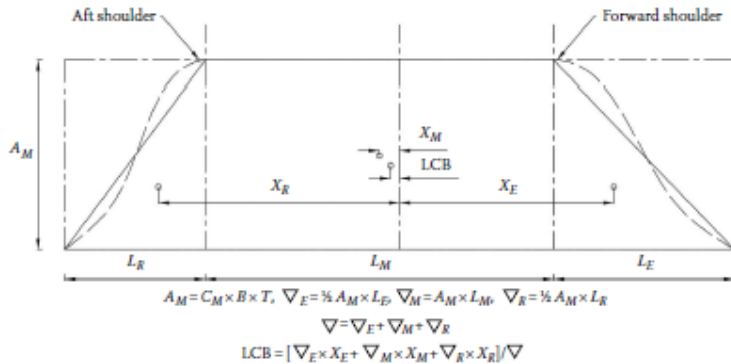

# Determination of hull form

## Longitudinal location of the midship / main section

In terms of resistance, for fast ships it is beneficial to move the midship area towards the aft, thus increasing the length of the entrance of the sectional area curve

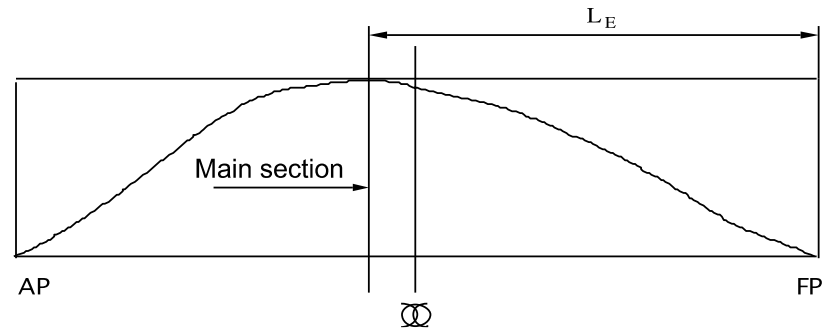
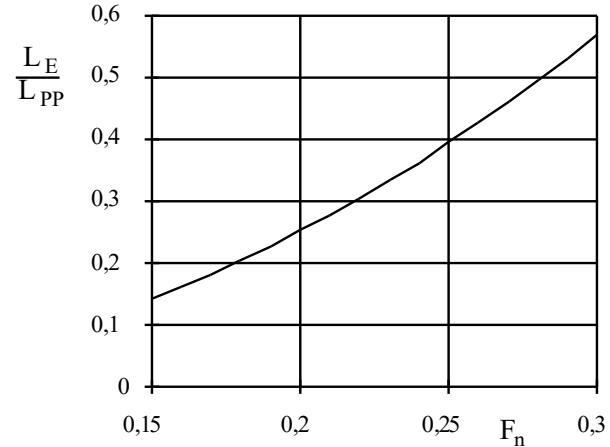

# Determination of hull form - Sectional area curve

- Includes the determination of the
  - Prismatic coefficient  $C_P$
  - Longitudinal centre of buoyancy LCB
  - Location of the maximum sectional area
  - The length of the parallel section of constant sectional area
  - The midship section area coefficient  $C_M$

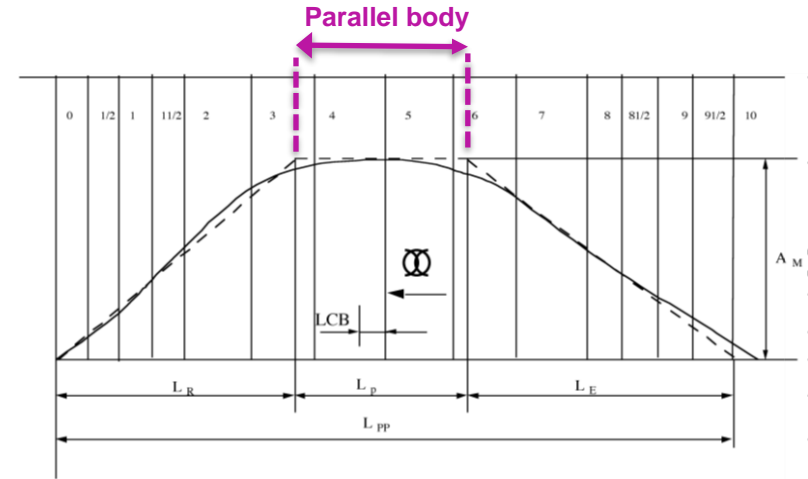

$$C_P = \frac{\nabla}{L A_M}$$

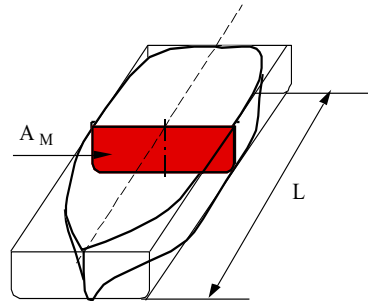

$$C_M = \frac{A_M}{B T}$$

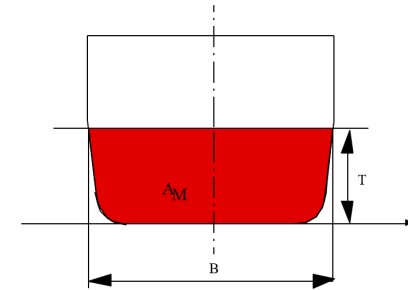

# Determination of hull form – Prismatic Coefficient ( $C_p$ )

- Determined as a function of the Froude number (Reference curves are based on model tests)
- For slow ship, the frictional resistance is around 80% of the total resistance
- For faster ships the wave making resistance is significant, and it is sensitive to the entrance angle of the bow

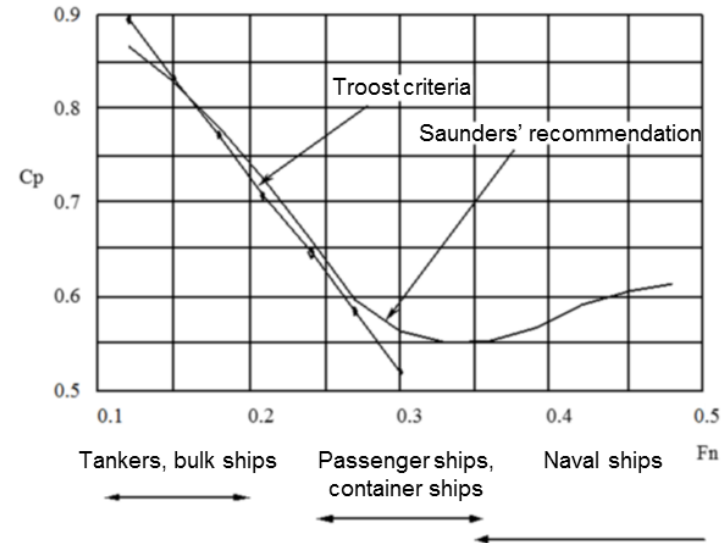

Sectional area curves for two different  $C_p$

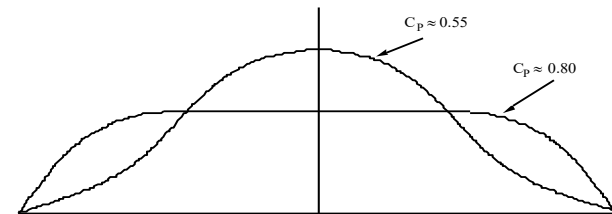

# Determination of hull form - LCB

- Longitudinal Centre of Buoyancy (LCB) is aft of the mid-ship for small prismatic coefficient ( $C_p$ ) values, and ahead of the mid-ship for large  $C_p$  values. **LCB location depends on the sharpness of the bow and stern.**
- For fast ships (small  $C_p$ ), the wave making resistance is significant. This calls for a small entrance angle and thus small fullness at the bow.
- For slow ships, the wave making is not significant and the wetted area at the bow can be minimized by having a full bow. The same does not hold at the stern, because a full stern would result in a strong, or even separated wake at the propeller plane. Thus the stern has to be slender.
- **The LCB cannot be defined purely based on hydrodynamics, because the ship must float on even keel in different loading conditions.** In some cases this means that the LCB has to be moved away from the hydrodynamic optimum.

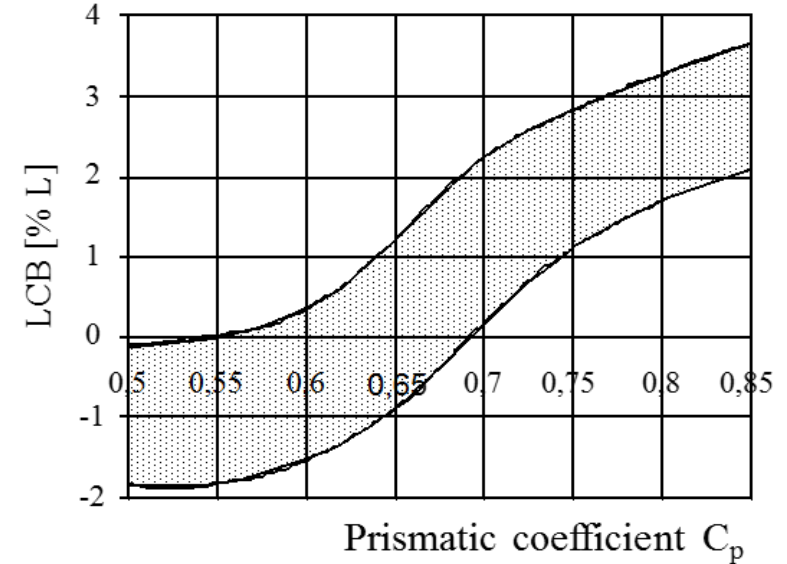

# Determination of hull form - $L_{pp}$

The length of the parallel mid-body  $L_{PP}$  is the ship length for which the midship section is constant in area and shape

- $L_{PP}$  increases as a function of the prismatic coefficient  $C_p$ .
- As the mid-body length increases, the aft and fore shoulders become more prominent.
- As the prismatic coefficient decreases to roughly 0.65, the parallel mid-body vanishes.

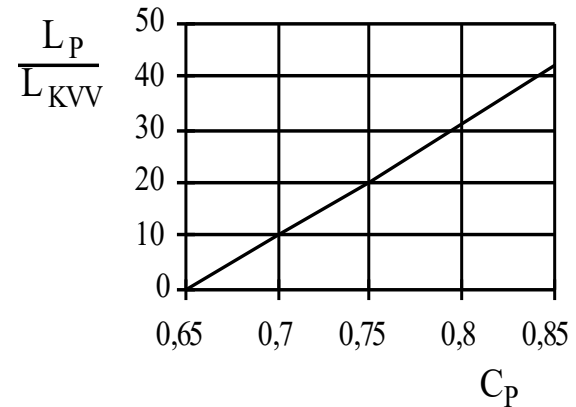



# Determination of hull shape - WPA

- Waterplane area varies due to waves
- Designers tend to maximise the waterplane area ( $C_{WP}$  ratio) to satisfy stability requirements.
- However, the value from the reference curves should only be a target in the lines design, as otherwise the fairness of the lines is compromised and the residuary resistance increases



Waterplane area in still water, GM

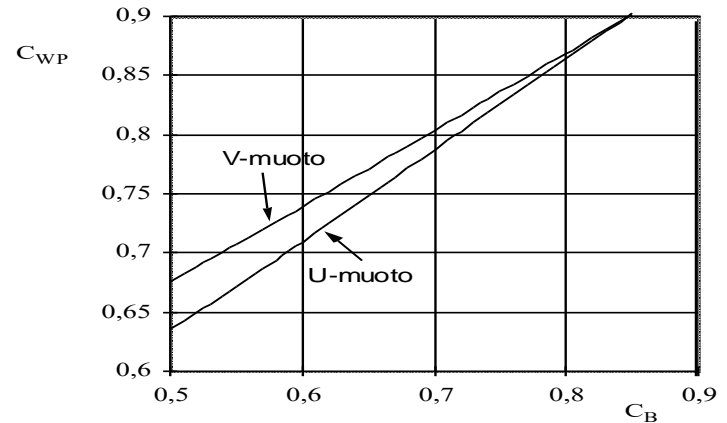

# Determination of hull shape

## Different types of mid-ship section forms

- Normal
  - Flat bottom, vertical sides and a rounded bilge
  - Suitable for normal cargo ships
- Large bilge
  - Suitable for fast ships
- Midship area coefficient  $C_M < 0,9$ 
  - Improves the flow around the bilge
  - Raises the centre of buoyancy  $KB \rightarrow$  Improved stability
  - Decreases roll damping  $\rightarrow$  larger rolling angles
  - Improves the draining of double bottom tanks
  - Increases the manufacturing costs of the steel structure
- Inclined sides
  - Limits compressive ice loads, suitable for ice class ships
  - Provides improved damaged stability
  - Improves the strength of an open ship

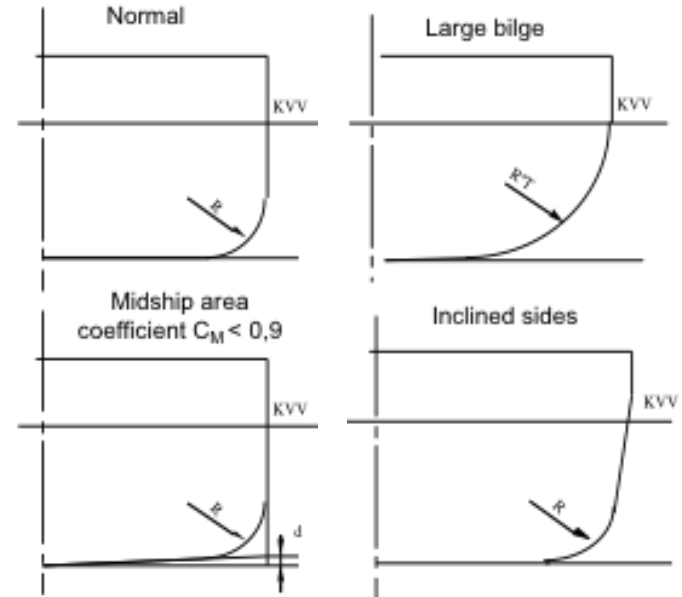

# Determination of hull shape – Stem profile

- Inclined stem
  - *Good in rough seas*
    - ✓ Provides reserve buoyancy
    - ✓ Encountered waves are thrown to the sides
    - ✓ Reduces slamming loads
  - *Provides good collision protection*
  - *Considered aesthetically beautiful*
  - *Simple to construct*
  - *Nowadays mostly used in small ships*

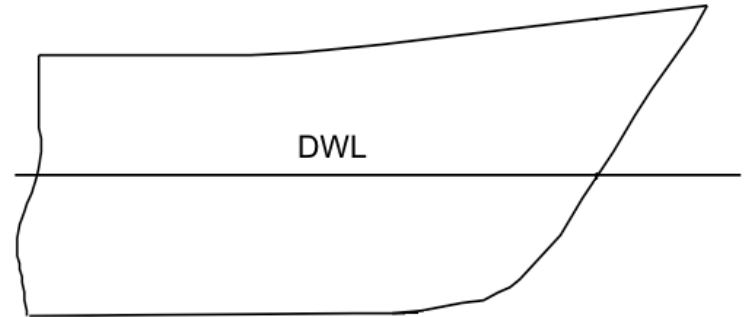

# Determination of hull shape – Bulbous bow

- ❑ *Traditionally used on ship with  $F_n > 0.23$ , where the residuary resistance related to wave making can be decreased; at the same time entrance angle can be decreased*
- ❑ *The use has been extended to ships with  $F_n$  between 0.15 and 0.23*
- ❑ *Can reduce the required propulsion power by up to 20 %*
- ❑ *Increases the wetted surface, which affects the frictional resistance*
- ❑ *Expensive to build*



# Determination of hull shape – V versus U shape Bow

- Ship GA:
  - ✓ *V-shape Larger exploitable volume above the waterline and larger deck area*
  - ✓ *U-shape has better exploitable space below the waterline.*
- Ship stability:
  - ✓ *V-shape widens the waterline*
  - ✓ *U-shape results in a higher location of the center of buoyancy*
- Resistance:
  - ✓ *V-shape provides a smaller wetted surface, lower frictional resistance*
  - ✓ *U-shape results in a higher wave making resistance*
- Steel structure:
  - ✓ *V-shape lower building costs*
- Wave loads:
  - ✓ *V-shape lower the slamming pressure on the bottom*
  - ✓ *U-shape results in a larger wave load on the bow*

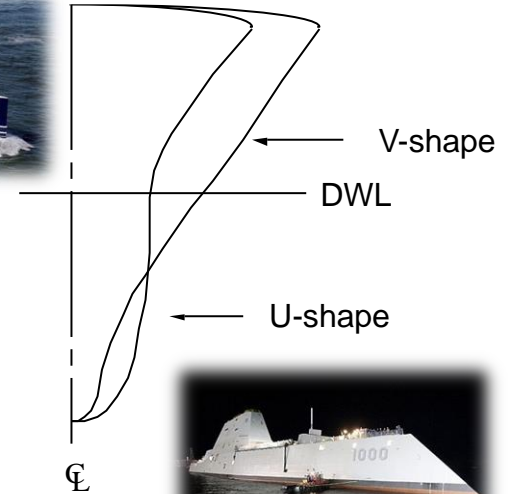

# Determination of hull shape – Stem profile

## Stem profile

- Icebreaking bow
  - *Results in a bending vertical force on the ice field breaking the ice*
  - *Increases the open-water resistance*
  - *Reduced displacement, poorer sea-keeping characteristics , increased slamming loads*
  - *Small wetted surface area at the bow → reduced frictional resistance*
  - *Simple to build*
  - *Double Acting Tanker (DAT) concept*
    - ✓ *Ship with an ice-breaking stern and an open-water bow*
    - ✓ *Operates stern-first in ice*

Ice-breaking bow



Open water bow



# Determination of hull shape – Stern profile

- **V-Elliptic (merchant) and cruiser stern:**

- *Originate from the sailing ship era, common before the 1930s, still used on tugs*

- **Transom stern**

- *Applied on modern ships*
- *when  $Fn \leq 0,3$  transom should be above waterline, duck-tail can be used to increase length*
- *when  $Fn \geq 0,3$  lowest point of the transom at roughly 10% of the draft  $T$ ; reduces residuary resistance*
- *large water-plane area improves stability in still water, but large changes in water-plane area in waves, possible problems with stern slamming*

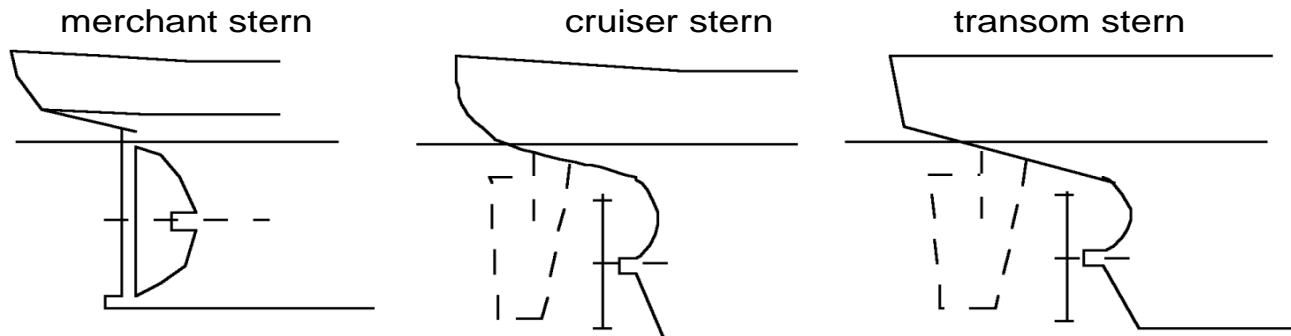

# Determination of hull shape – Stern profile

## Stern profile, items to consider

- ✓ Propulsion efficiency more important than resistance
- ✓ Minimisation of flow separation, WL angle
- ✓ Importance of homogenous wake
- ✓ Single screw arrangement is more energy-efficient than twin screw arrangement
- ✓ Propeller air suction must be avoided
  - ✓ *Propeller(s) must be in water at all time*
- ✓ Propeller clearances (class recommendations)

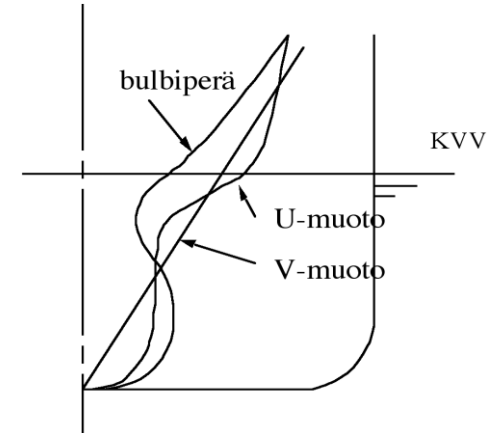

## Design alternatives

- ✓ V- shape: small resistance, non-homogenous wake, twin screw arrangement
- ✓ U-shape: homogenous wake
- ✓ twin skeg: twin screw arrangement, which aims for a propulsive efficiency comparable to a single screw arrangement

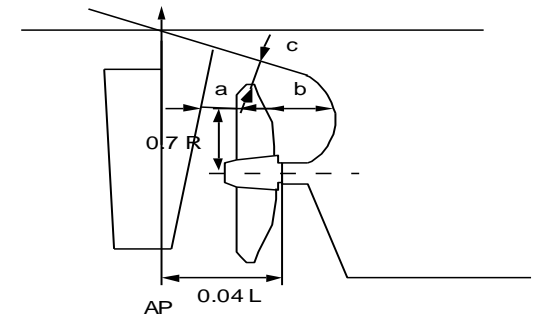



# Determination of hull shape - Stern profile

## Consideration of the type of propulsion

- Azimuth thrusters, shaft propeller, waterjet,...

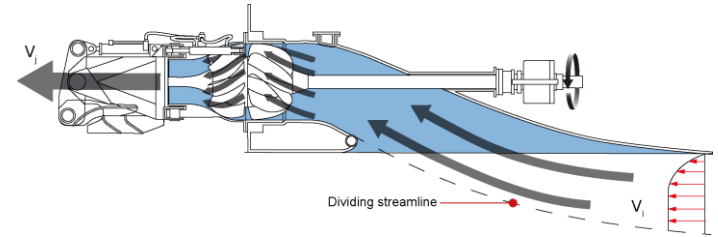
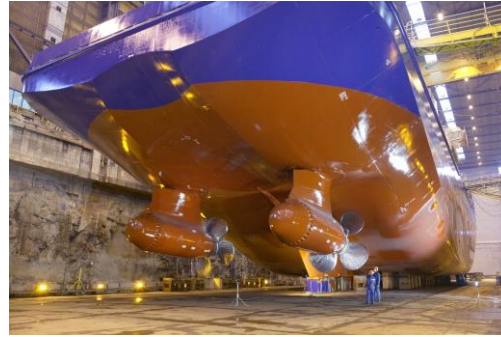
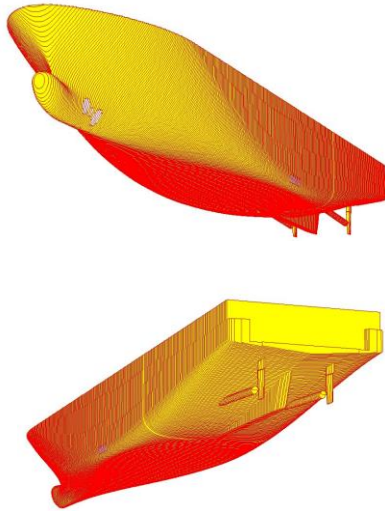

# Simulation based design

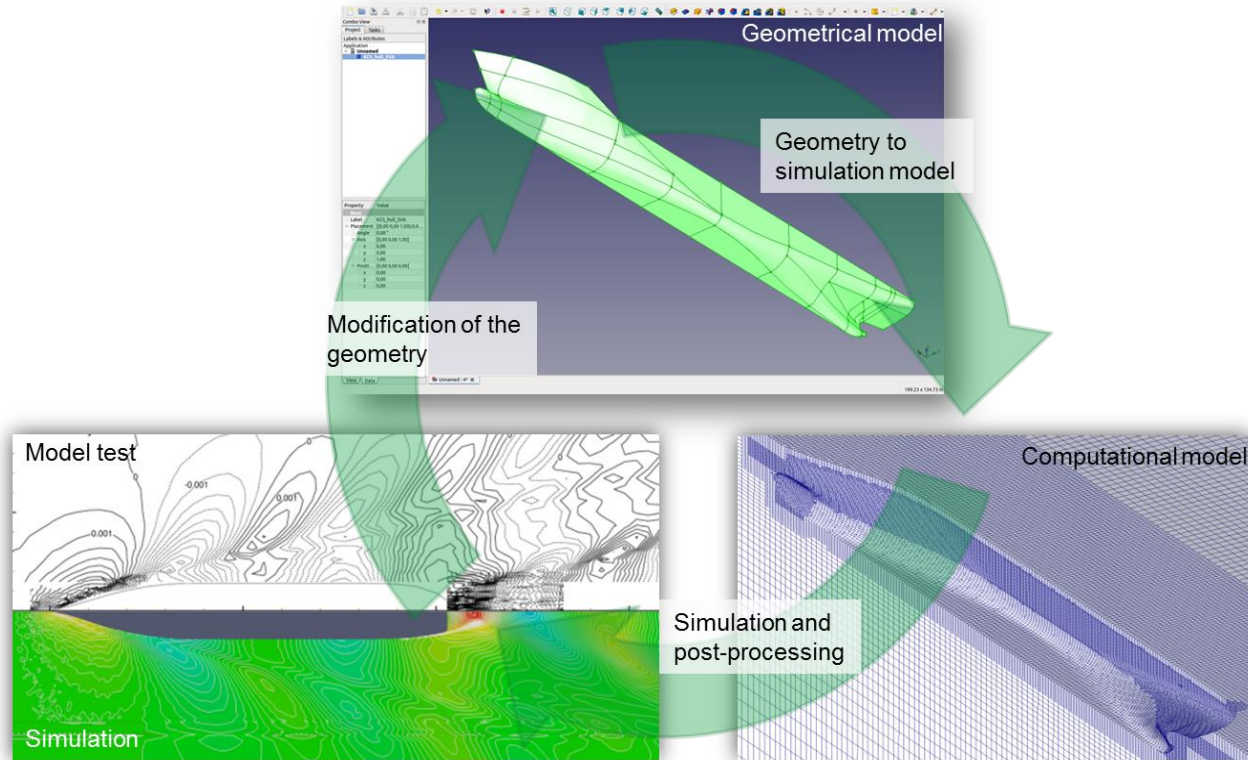

# Summary

- Hull form creation is a complex and iterative process that requires the consideration of a wide range of factors
  - *Ship functionality (main dimensions, GA), buoyancy, stability requirements, hydrodynamic resistance, propulsion efficiency,...*
- Design variables
  - *Main dimensions (unless fixed), section area curve shape (level of fullness, location of the center of gravity, etc.), stem profile, stern profile, midship profile,...*
- The form of a hull is defined/presented by lines drawings
  - *Three projections: body plan, profile / sheer plan, half-breath / waterlines plan*

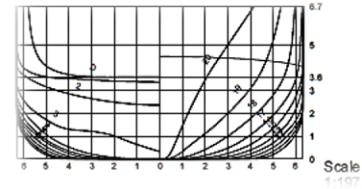

Image credit Developers of the "Suomi 100" ship concept



Aalto University  
School of Engineering

***Thank you !***