

### **3. LOAD LINE ASSIGNMENT**

#### **Load Line**

The load line is a formal term given to the mark located amidships on both sides of a ship to show the limiting draft to which the vessel may be loaded. This is obtained by measuring from the uppermost continuous watertight deck (normally the freeboard deck) down to the load line mark amidships. This distance is called the freeboard of the ship.

#### **Standard Ship**

In order to assign a load line properly, it is necessary to compare the design to a geometric ship of standard form.

##### a- The International Convention on Load Lines (ICLL 1930)

The standard ship had:

- An  $L/D = 15$
- A fineness coefficient of  $0.68$
- A standard sheer
- A standard camber of the main deck
- A minimum percentage length of superstructure
- A required forecastle for tankers

##### b- The ICCLL 1966 Standard Ship

It is similar to the 1930 standard ship except for the camber requirement which was dropped and the forecastle requirement which was removed in favour of a minimum bow height. The fineness coefficient was redefined as the block coefficient.

#### **Need for Adequate Freeboard**

1. The safety of the ship. The greater the amount of freeboard, the greater the amount of reserve buoyancy, and therefore the greater chance of remaining afloat when damaged.

2. The amount of freeboard also plays an important part in the stability of the ship, as large freeboard means that the ship can be inclined to a large angle before deck edge becomes submerged.
3. The safety of the crew. A ship has to work in all weathers, and inadequate freeboard would mean that waves could easily swamp the decks, thus reducing the safety and comfort of the crew.

## **LOAD LINE CALCULATIONS**

### **Type of Ships**

For the purpose of freeboard calculations, ships are divided into two types:

#### **I- Type A Ships**

A type A ship is one which is designed to carry only liquid cargoes in bulk and in which cargo tanks have only small access openings closed by watertight gasketed covers of steel or equivalent material.

#### **II- Type B Ships**

All ships which do not come within the provisions regarding Type A ships are to be considered as Type B ships.

### **Freeboard Table for Type A and Type B Ships**

| Length of Ship<br>(m) | Type A<br>(mm) | Type B<br>(mm) |
|-----------------------|----------------|----------------|
| 24                    | 200            | 200            |
| 50                    | 443            | 443            |
| 76                    | 786            | 816            |
| 100                   | 1135           | 1271           |
| 150                   | 1968           | 2315           |
| 200                   | 2612           | 3264           |
| 250                   | 3012           | 4018           |
| 300                   | 3262           | 4630           |
| 350                   | 3406           | 5160           |
| 365                   | 3433           | 5303           |

### **Freeboard Deck**

The depth of the vessel used for the calculation of freeboard depends upon which deck is considered to be the freeboard deck. The freeboard deck is normally the

uppermost continuous deck having permanent means of closing all exposed openings which would allow water to enter the hull or superstructures.

### **Dimensions for Freeboard**

#### **a- Length (L)**

$L$  is taken as 96% of the total length on a waterline at 85% of the least moulded depth measured vertically from the top of the keel, or as the length from the fore side of the stem to the axis of the rudder stock on the waterline, if that is greater.

#### **b- Breadth (B)**

$B$  is the maximum breadth measured amidships to the moulded line of the frame.

#### **c- Depth of Freeboard ( $D_f$ )**

$D_f$  is the moulded depth amidships plus the thickness of the freeboard stringer plate.

### **Basic Minimum Freeboard**

The first step in the calculations is to obtain from the applicable table for the ship type, A or B, the basic minimum tabular freeboard. The tabular freeboard for a type B ship between 24 m and 100 m in length having enclosed superstructures with an effective length of up to 35% of the length of the ship must be increased by:

$$7.5 (100 - L) \left( 0.35 - \frac{E}{L} \right) \text{ mm}$$

Where  $L$  = freeboard length,

$E$  = effective length of superstructure

To this basic freeboard the various corrections are applied to arrive at the minimum freeboard to be assigned.

### **Corrections for Freeboard**

#### **a- Correction for Block Coefficient**

$$C_B \text{ for freeboard purpose} = \frac{\text{moulded volume at } d_1}{L B d_1}$$

Where  $d_1$  = moulded draft at 0.85 of the least moulded depth.

When  $C_B$  is greater than 0.68 the basic freeboard is multiplied by:

$$\frac{C_B + 0.68}{1.36}$$

If  $C_B$  is less than 0.68, then 0.68 should be used.

### **b- Correction for Length-to-Depth Ratio**

The standard  $L/D = 15$

Where  $D$  exceeds  $L/15$  : the freeboard is increased by  $R(D - L/15)$ , where  $R$  in mm =  $L/0.48$  at lengths < 120 m, and  $R = 250$  mm at 120 m and above.

Where  $D$  is less than  $L/15$  : a reduction in freeboard is allowed only if there is an enclosed superstructure covering at least  $0.6 L$  amidships, or a combination of intact superstructures and a trunk. In such cases the reduction is at the same rate as for an excess of  $D$  (A trunk is a tight structure which does not extend to the sides of the vessel)

### **c- Correction for Superstructure**

A superstructure is a decked watertight structure on the freeboard deck, extending from side to side, or with superstructure side plating not inboard of the shell plating more than 4%  $B$ . A raised quarter deck is regarded as a superstructure.

#### **Length of Superstructure**

$S$  is the mean length of the parts of superstructure which lie within the vessel's length  $L$ . If the end bulkhead is not square across the ship, an "equivalent bulkhead" is used.

#### **Height of Superstructure**

The actual height of the superstructure,  $h_a$ , is the least vertical height measured at side from the top of the superstructure deck beams to the top of the freeboard deck beams.

The standard height of the superstructure,  $h_s$ , is given below:

|                      |                                  |
|----------------------|----------------------------------|
| Raised quarter decks | 0.90 m for $24 < L < 30$         |
|                      | 0.90 – 1.07 m for $30 < L < 122$ |
|                      | 1.07 m for $L > 122$             |

|                       |                                   |
|-----------------------|-----------------------------------|
| Other superstructures | 1.80 m for $24 < L < 75$          |
|                       | 1.80 m – 2.3 m for $75 < L < 125$ |
|                       | 2.30 m for $L > 125$              |

A raised quarter deck is a stepped deck extending from the after perpendicular with no opening in the vertical bulkhead forming the forward boundary.

When  $h_a < h_s$

The effective length of superstructure  $E = S \times h_a / h_s$

When  $h_a > h_s$  no increase is made in the effective length

### **Breadth of Superstructure**

If the superstructure is set in from the sides of the ship not more than 4%  $B$

The effective length  $E = S \times b / B_s$

Where  $b$  is the breadth of superstructure at the middle of its length,

$B_s$  is the breadth of the ship at the middle of the length of the

Superstructure

A superstructure subjected to corrections due to height and breadth will be:

$$E = S \times \frac{b}{B_s} \times \frac{h_a}{h_s}$$

### **Bulkhead Effectiveness**

For a superstructure to be credited as enclosed it must have bulkheads of efficient construction. If access openings are placed in these bulkheads, the openings are to be fitted with doors of steel or other equivalent material and provided with gaskets and clamping devices. The doors should be arranged so that they can be operated from both sides of the bulkheads.

A bridge or poop is not regarded as enclosed unless access is provided for crew to reach machinery and other working spaces inside these superstructures by alternative means.

### **Trunks**

A trunk or similar structure which does not extend to the sides of the ship is given credit as for superstructures and is regarded as efficient provided:

- The breadth of the trunk is at least 60% of the breadth of the ship.
- Where there is no superstructure, the length of the trunk is at least  $0.6 L$

The full length of an efficient trunk reduced to the ratio of its mean breadth  $b$ , to the breadth of the ship,  $B$ , is its effective length.

### **Deduction for Superstructures and trunks**

Where the total effective length of superstructures and trunk is less than  $1.0 L$ , the deduction is a percentage obtained from the following table:

| $(\Sigma E) / L$ | ( I )<br>Ships with forecastle and<br>without detached bridge<br>% | ( II )<br>Ships with forecastle and<br>detached bridge<br>% |
|------------------|--|---|
| 0.1              | 5  | 6.3   |
| 0.2              | 10   | 12.7  |
| 0.3              | 15   | 19  |
| 0.4              | 23.5   | 27.5  |
| 0.5              | 32   | 36  |
| 0.6              | 46   | 46  |
| 0.7              | 63   | 63  |
| 0.8              | 75.3   | 75.3  |
| 0.9              | 87.7   | 87.7  |
| 1.0              | 100  | 100   |

This percentage is then multiplied by the deduction allowed for a vessel with 100% superstructure which is obtained as follows:

| <u><math>L</math></u> | <u>Deduction</u> |
|-----------------------|------------------|
| 24 m                  | 350 mm           |
| 85 m                  | 860 mm           |
| 122 m and above       | 1070 mm          |

Deductions at intermediate lengths are obtained by linear interpolation where the effective length of a bridge is less than  $0.2 L$  the percentages are obtained by linear interpolation between columns I and II.

### **d- Correction for Sheer**

The standard vessel (ICLL 1966) has a standard sheer profile consisting of two parabolas, one forward and one aft of amidships. If the actual sheer is greater

than the standard shear the basic freeboard may be reduced; if it is less, the freeboard must be increases.

### Sheer Line

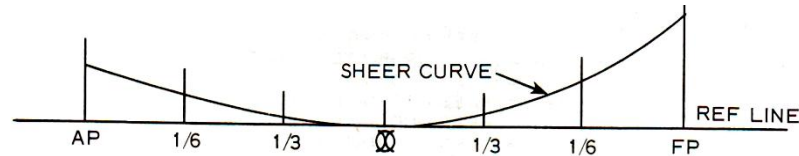

The sheer is measured vertically from the deck at side to a line of reference drawn parallel to the base line through the sheer line at side amidships. The sheer, at amidships of the standard sheer profile is zero. The ordinates for the standard sheer curve are given below:

|         | Station<br>(L in m) | Ordinates<br>(mm)   | Factor<br>(S.M.) |
|---------|---------------------|---------------------|------------------|
|         | A.P.                | 25 ( $L/3 + 10$ )   | 1                |
| After   | L/6 from A.P.       | 11.1 ( $L/3 + 10$ ) | 3                |
| Half    | L/3 from A.P.       | 2.8 ( $L/3 + 10$ )  | 3                |
|         | Amidships           | 0                   | 1                |
|         | Amidships           | 0                   | 1                |
| Forward | L/3 from F.P.       | 5.6 ( $L/3 + 10$ )  | 3                |
| Half    | L/6 from F.P.       | 22.2 ( $L/3 + 10$ ) | 3                |
|         | F.P.                | 50 ( $L/3 + 10$ )   | 1                |

### Sheer Comparison with Standard

The actual sheer profile on the vessel is compared with the standard sheer profile. On the actual vessel the sheer at amidships is considered zero, even though the lowest point of the actual ship may not be amidships. The sheer at any point forward or aft of amidships is always with reference to zero sheer amidships.

If the actual sheer curve at one of the specified ordinates given in the table falls below the sheer reference line a negative sheer ordinate value should be used.

### Sheer Formula Computation and Comparison

The ordinates of the actual and standard profiles are multiplied by the appropriate factor given in the table. The difference between the sums of products of the actual profile and those of standard is divided by 8.

$$\text{Deficiency or excess of sheer} = \frac{\text{Difference between the sums of products}}{8}$$

$$\text{Sheer Correction} = \text{Deficiency or excess} \times \left(0.75 - \frac{S}{2L}\right)$$

Where  $S$  = total length of enclosed superstructure

### **e-Minimum Bow Height**

The bow height is defined as the vertical distance at the forward perpendicular between the waterline and the top of the exposed deck at side.

For ships  $< 250$  m

$$\text{Bow height} \leq 56L \left(1 - \frac{L}{500}\right) \times \frac{1.36}{C_B + 0.68} \quad \text{mm}$$

For ships  $\geq 250$  m

$$\text{Bow height} \leq 7000 \times \frac{1.36}{C_B + 0.68} \quad \text{mm}$$

### **Reduced Freeboard for Type B Ships**

A type B ship over 100 m in length may be assigned a freeboard less than that usually assigned for a ship of the same geometric particulars provided:

- The ship is provided with appropriate steel watertight hatch covers.
- The freeing port arrangements are adequate.
- The ship when loaded to its summer load waterline, will remain afloat after flooding of any single damaged compartment at an assumed permeability of 0.95 excluding the machinery space.
- In ships over 225 m in length, in addition to the above the machinery space shall be treated as a floodable compartment but with a permeability of 0.85.



### **Type B Ship 60% Freeboard Reduction**

For type B ships which comply with the criteria stated above, the tabulated freeboard value can be reduced by not more than 60% of the difference between the values obtained from the freeboard table for type B and type A ships for the appropriate ship length.

### **Type B Ship 100% Freeboard Reduction**

This reduction may be increased up to the total difference between the values for type B and type A ships provided the ship complies with the machinery casing, freeing port arrangements, and gangway and access requirements for type A ships.

### **Damage Stability Requirements**

1. The final waterline after flooding is below the lower edge of any opening through which progressive flooding may take place.
2. The maximum angle of heel due to unsymmetrical flooding is in the order of  $15^{\circ}$
3. GM in the flooded condition is positive.

### **Type A Ships**

The type A ships in addition to the basic requirements should include the following features:

- A high integrity of the exposed deck
- A high degree of safety against flooding
- A gangway at the level of the superstructure deck with safe access for the crew to quarters and working spaces
- Special protection for machinery casings
- Steel hatch covers for hatchways on exposed freeboard or superstructure decks
- Open rails for at least half the exposed weather deck

### **Seasonal and Fresh Water Freeboard Marks**

After the application of all the corrections to the basic freeboard, the result is "*the Minimum Summer Freeboard*" in sea water.

The freeboard is measured from the top of the deck amidships to the top of the line through the centre of the load line ring. Typical load line marks are shown in the following figure:

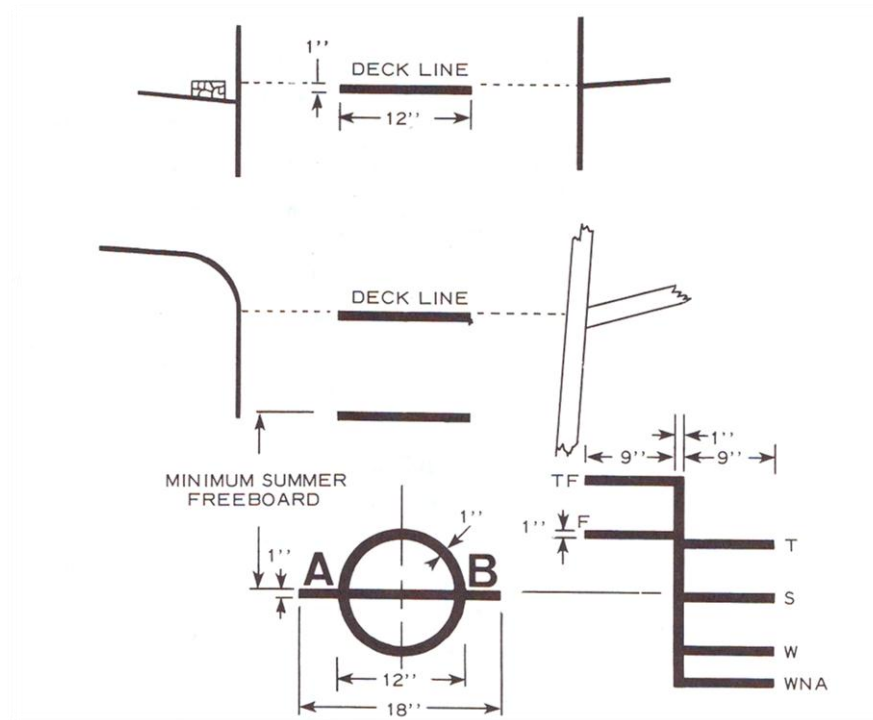

The various seasonal and fresh water marks are obtained as follows:

**a- Tropical Freeboard Mark (T)**

$$T = S - \frac{d}{48} \quad m$$

$d$  = summer draft measured from the top of the keel in m

The freeboard must not be less than 50 mm

**b- Winter Freeboard Mark (W)**

$$W = S + \frac{d}{48} \quad m$$

**c- Winter North Atlantic Freeboard Mark (WNA)**

For ships  $\leq 100$  m in length

$$WNA = W + 50 \quad mm$$

For other ships

$$WNA = W$$

**d- Fresh Water Marks (F and TF)**

$$F = S - \frac{\Delta}{40 TPC} \text{ cm}$$

Where  $\Delta$  = Displacement at the summer load waterline

$TPC$  = Tons per cm immersion at the draft

If the basic information is not available

$$F = S - \frac{d}{48}$$

$$TF = F \text{ allowance}$$

$$i.e. TF = F - \frac{d}{48}$$