

# Modelling Multihull vessel

# Contents

Pentamaran freight ship

Outrigger free modeling

Hydrostatics

# Multihull vessel

- The methods adopted in the “Ice Breaker from lines plan” and “Parametric transformation of Parent cruise ship” presentations can be employed to model a multihull vessel.
- Maxsurf Modeler has many parent models of Catamarans and trimarans. Check sample file
  - ✓ <C:\Program Files\Bentley\Offshore\MAXSURF CONNECT Edition V23\Sample Designs\Multihulls>.

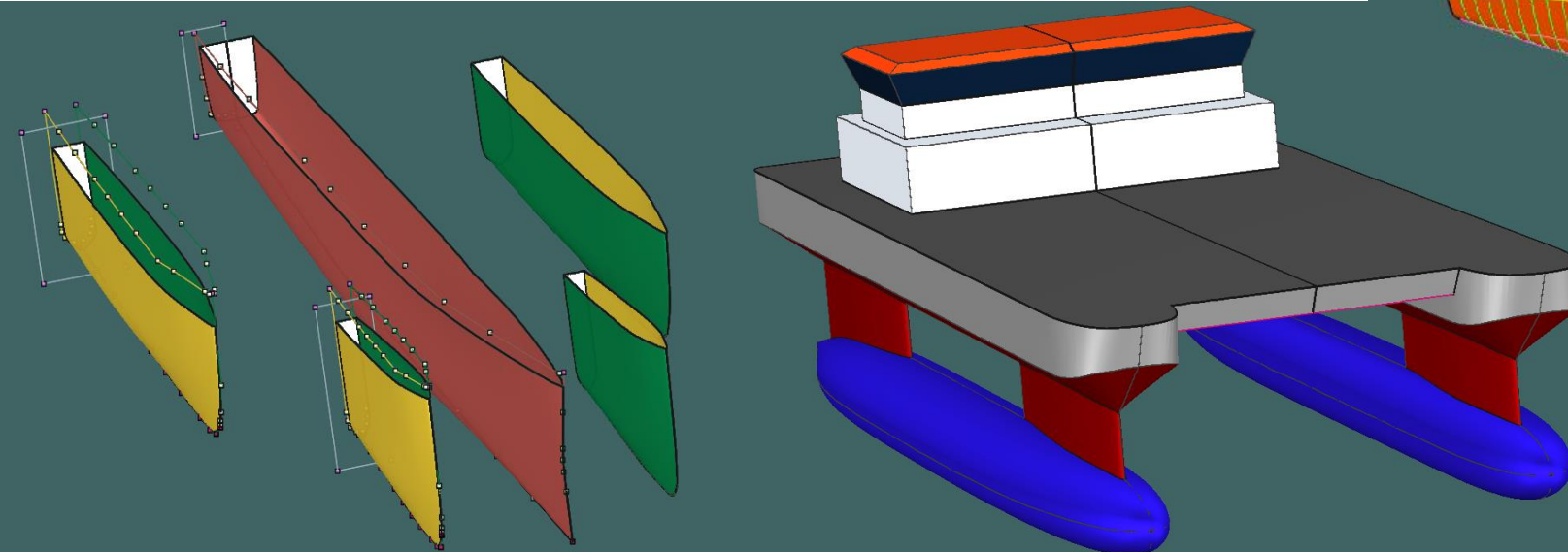
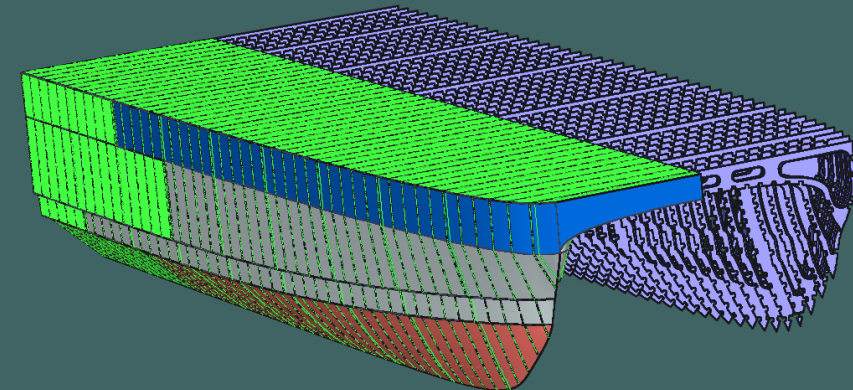
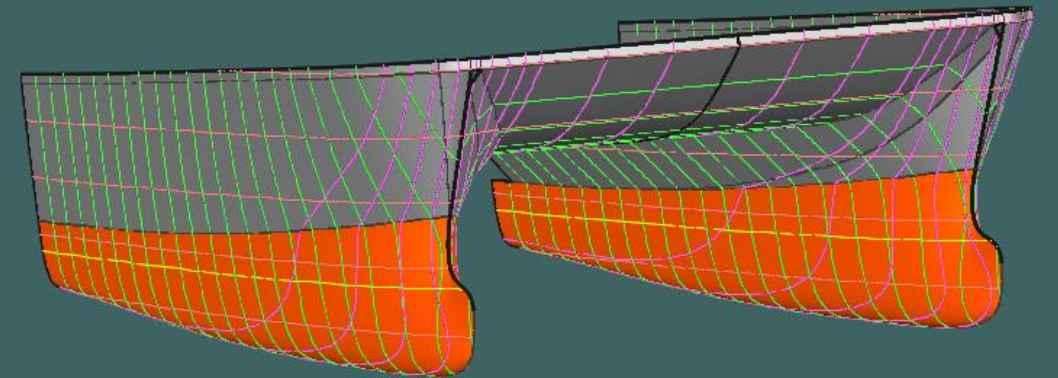
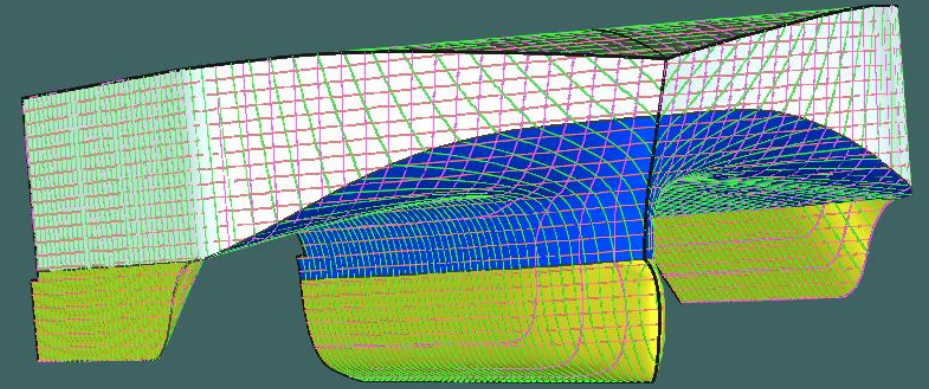

# Multihull vessel (Pentamaran freight ship)

- In this presentation we are going to model a pentamaran freight ship .
- For sake of simplification, the pentameran is assumed to have five hulls:
  - Main hull same as normal container ship with  $L = 209.2$  m  $B = 30$  m  $Draft = 10.4$  m  $C_B = 0.661$
  - Four outriggers of the same particulars (  $L_O = 30$  m  $B_O = 6.3$  m  $Draft_O = 5$  m  $depth = 10$  m  $C_{BO} = 0.6$ )

# Multihull vessel (Pentamaran freight ship)

- The Main hull is modeled using a parent model from Maxsurf Samples (similar as “Parametric transformation of Parent cruise ship” presentation)
- Open the parent model
  - ✓ “ContainerShip\_1Surface.msda” from Maxsurf Samples (C:\Program Files\Bentley\Offshore\MAXSURF CONNECT Edition V23\Sample Designs\Ships)
- Go to Data → Parametric transformation and change the main particulars to match the main hull characteristics.

Parametric Transformation

AP MS FP B

Parallel midbody

Aft midbody limit 0 m Forward midbody limit 0 m

Search For:

Block Coefficient 0.661 LCB aft of DWL(fwd) 50.25 % DWL

Prismatic Coefficient 0.666 LCF aft of DWL(fwd) 54.87 % DWL

Midship Area Coefficient 0.992  Topside Flare 0 Degrees

Waterplane Area Coefficient 0.842

Scale To:

Displacement 44226 t  Beam on DWL 30 m Density (water) 1.025 tonne/m<sup>3</sup>

Length on DWL 209.234 m  Immersed Depth 10.4 m

OK Cancel

Data Window Help Bentley

- Units...
- Coefficients...
- Design Grid...
- Inclined Sections...
- Frame of Reference...
- Vessel Type...
- Windage Surfaces...
- Target Section Area Curve...
- Girth...
- Calculate Offsets...
- Go To Offset...
- Go To Previous Offset
- Go To Next Offset
- Calculate Areas...
- Calculate Hydrostatics...
- Solve Calculations...
- Parametric Transformation...**
- AC Rule...
- Calculate Parts
- Verify Model...

# Multihull vessel (Outrigger free modeling)

- The outrigger is designed separately using free modeling technique
  - ✓ Open new Maxsurf Modeler.
  - ✓ Go to surfaces → add surface → Buttock plane
  - ✓ Switch to profile view
  - ✓ Change the longitudinal coordinate of the left control points to zero and right to 30 m.
  - ✓ Change the vertical coordinate of the bottom control points to zero and upper control points to 10 m (depth).

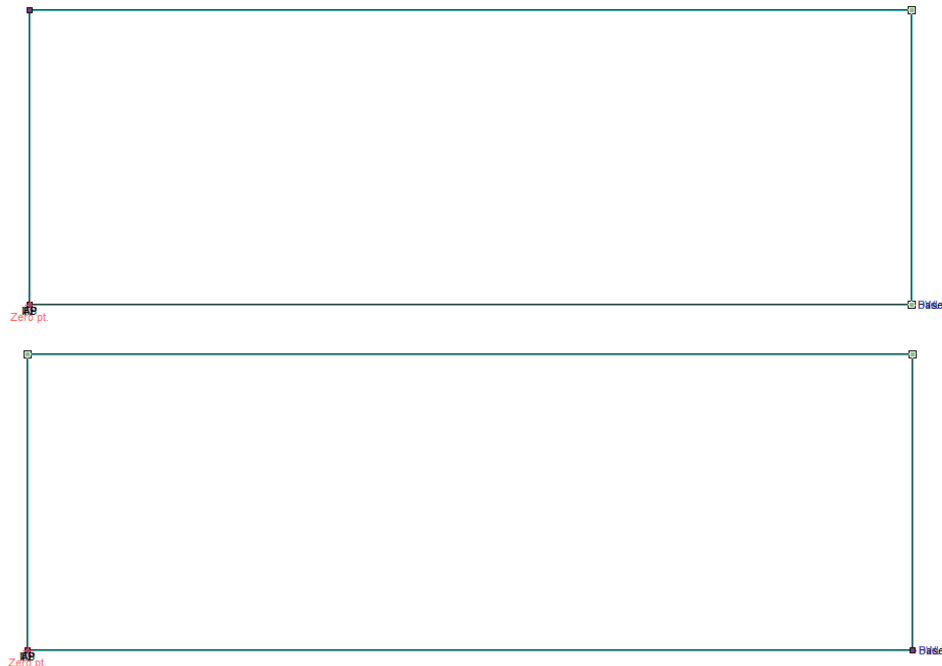
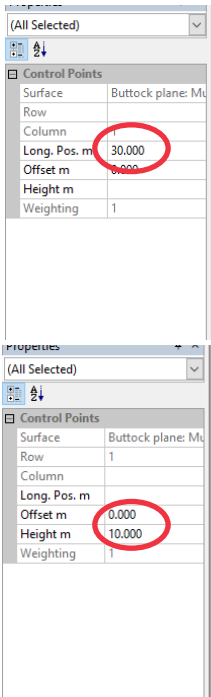
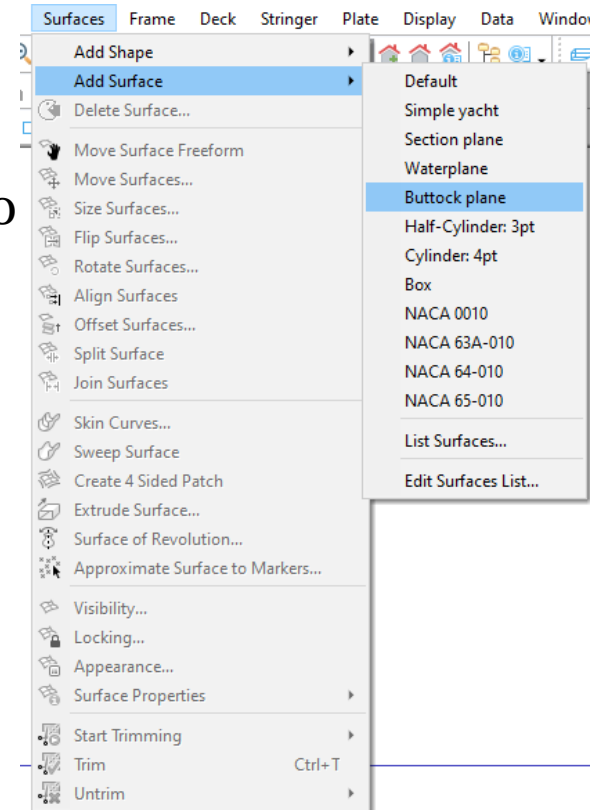

# Multihull vessel (Outrigger free modeling)

- Create net of control points; add suitable number of columns and rows according to the desired final shape.
- Shape the stem from profile view; all control points located at the stem should have zero offset.

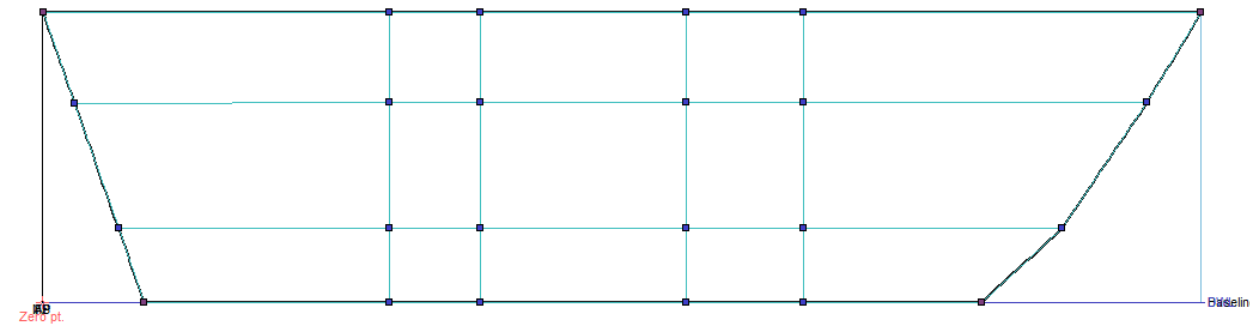
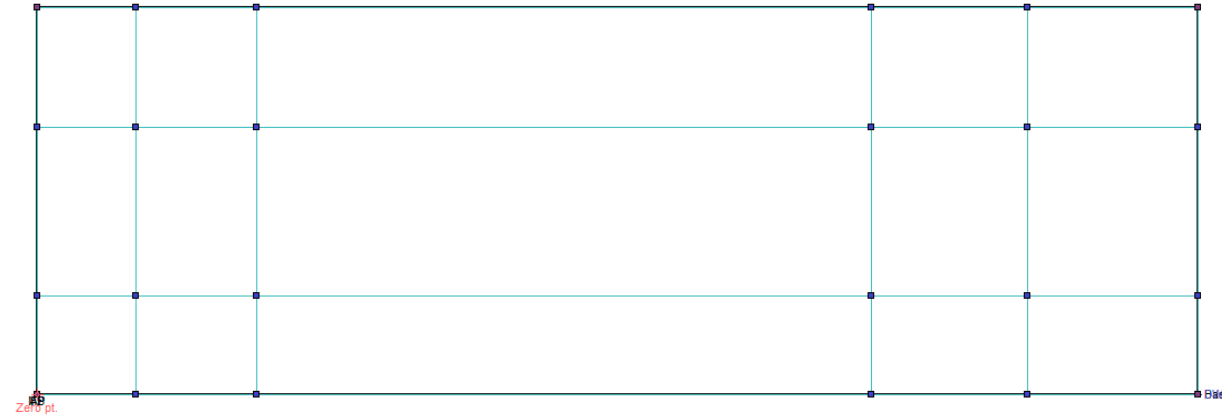

# Multihull vessel (Outrigger free modeling)

- **Mask a column or row of control points and manipulate it's control points to get the desired shape, for instance**
  - ✓ Select the first row of control points located at deck (preferably from profile view)
  - ✓ Go to Controls → Mask
  - ✓ Switch to plan view and start to shape the deck.
  - ✓ You can check the changes from perspective view ( Display → **render**)
  - ✓ Repeat the above procedures for the other rows and/or columns until you get a the desired hull form

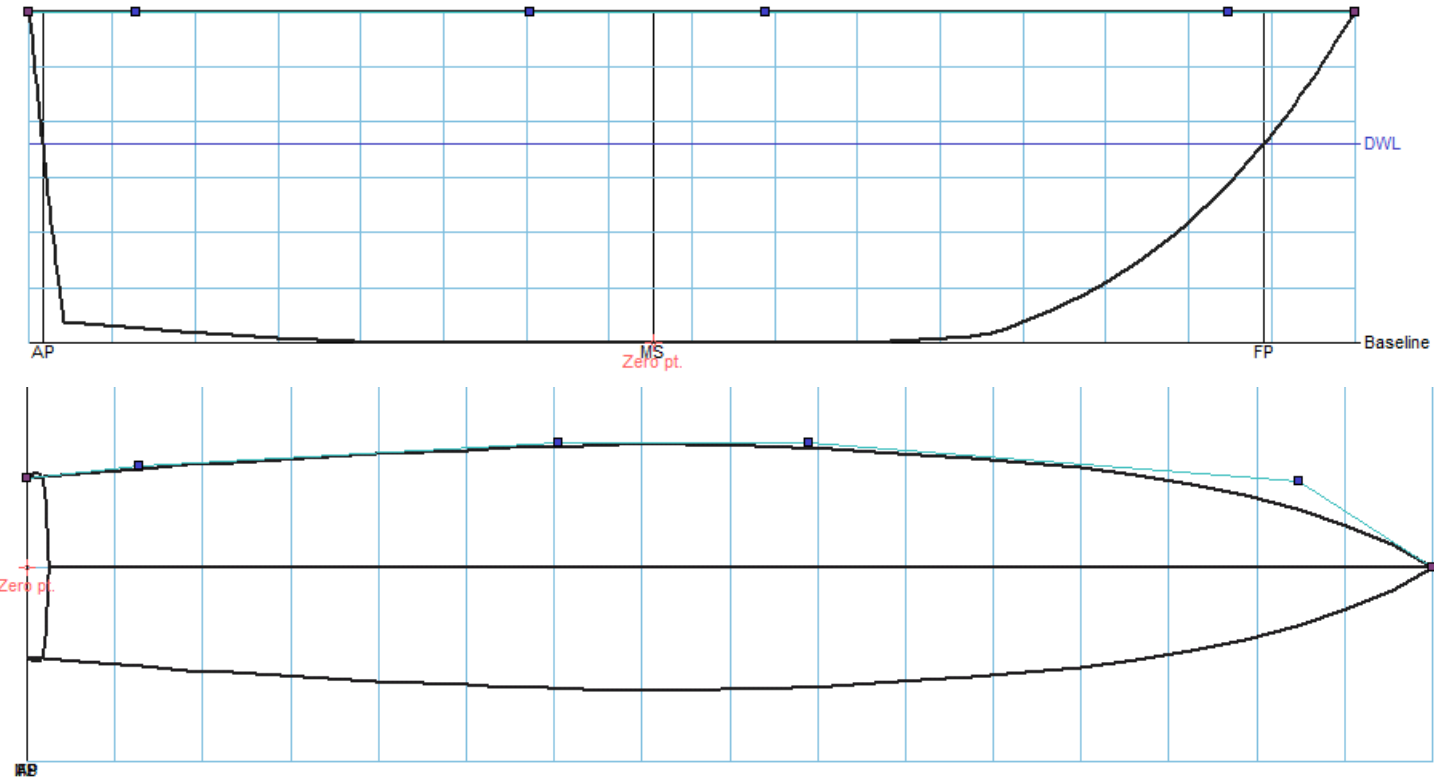



# Multihull vessel (Outrigger free modeling)

- After obtaining the desired hull form, start fairing the hull lines:
  - ✓ Add design grid (stations, buttocks and waterlines)
  - ✓ Manipulate the control points and/or change the surface stiffness to get fair hull form.

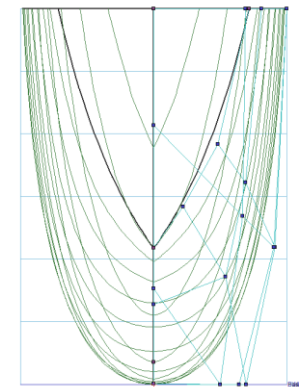
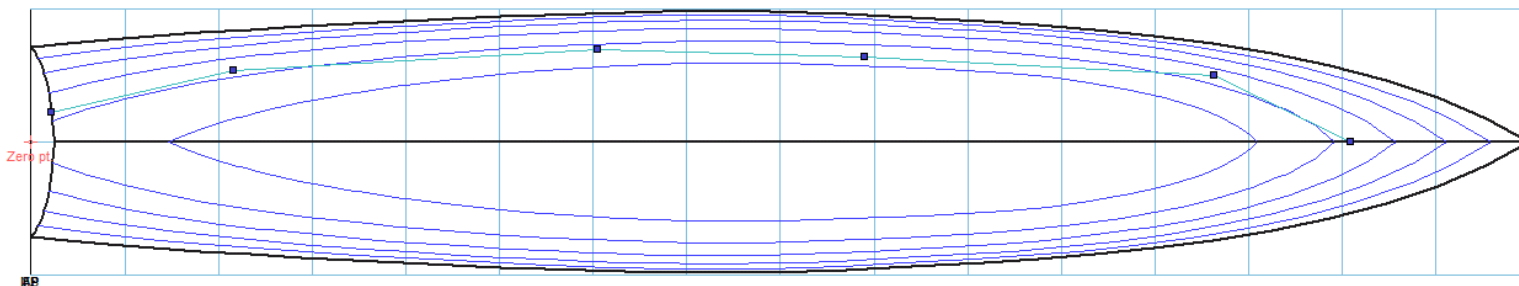
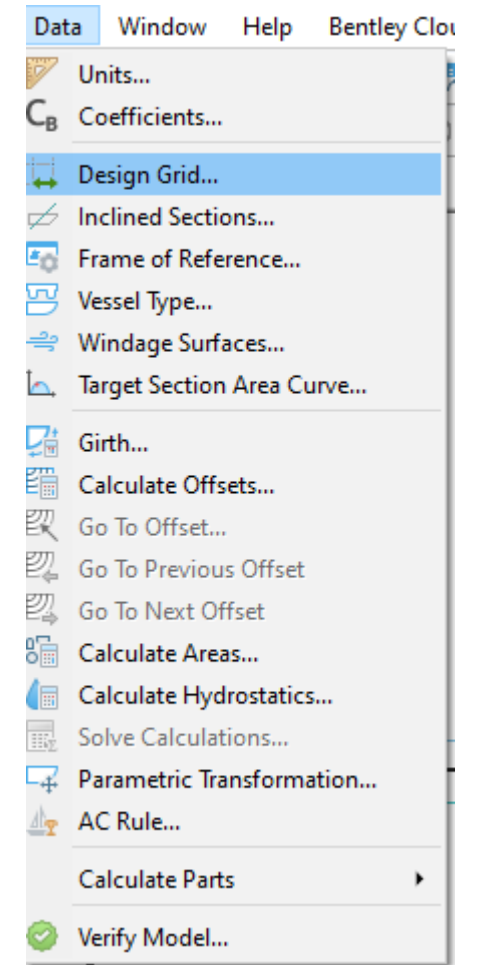
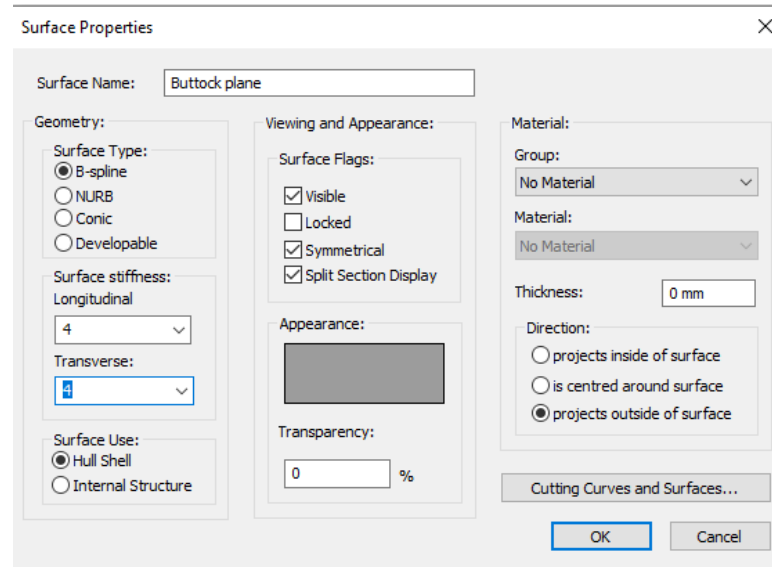
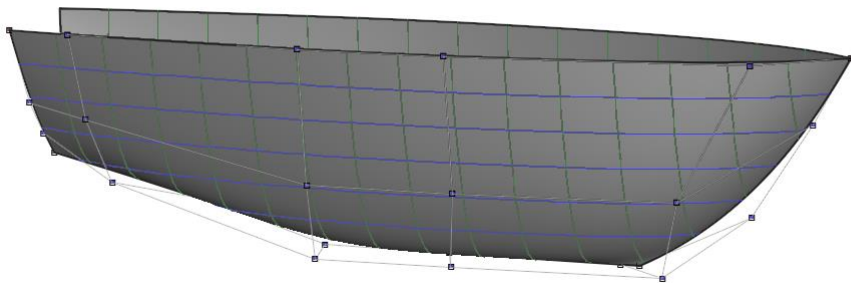

# Multihull vessel (Outrigger free modeling)

- **Check the outrigger hydrostatics**
  - ✓ Data → frame of reference and then define datum and aft and forward perpendiculars.
  - ✓ Data → Calculate hydrostatics
- **In case you need to change the main particulars of the outrigger as LCB,  $C_B$  and LWL:**
  - ✓ Go to Data → Parametric transformation and change the required values → search

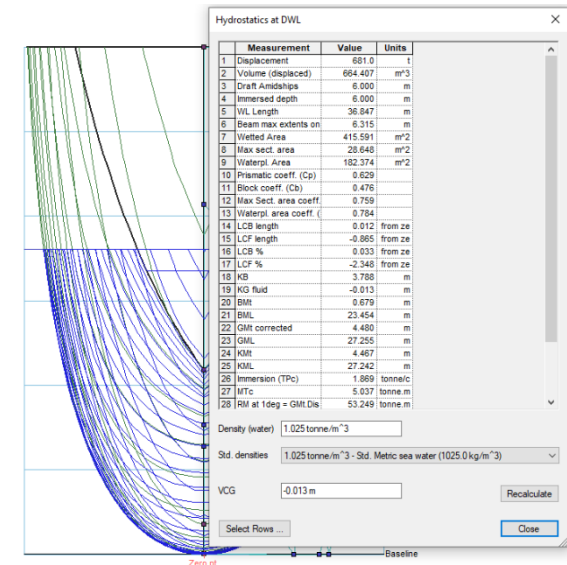
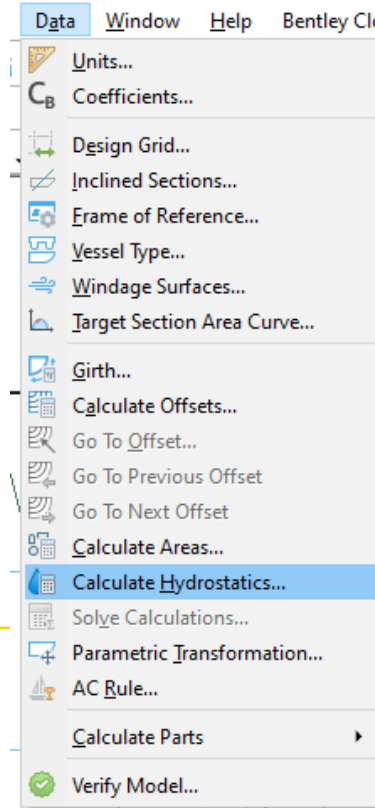
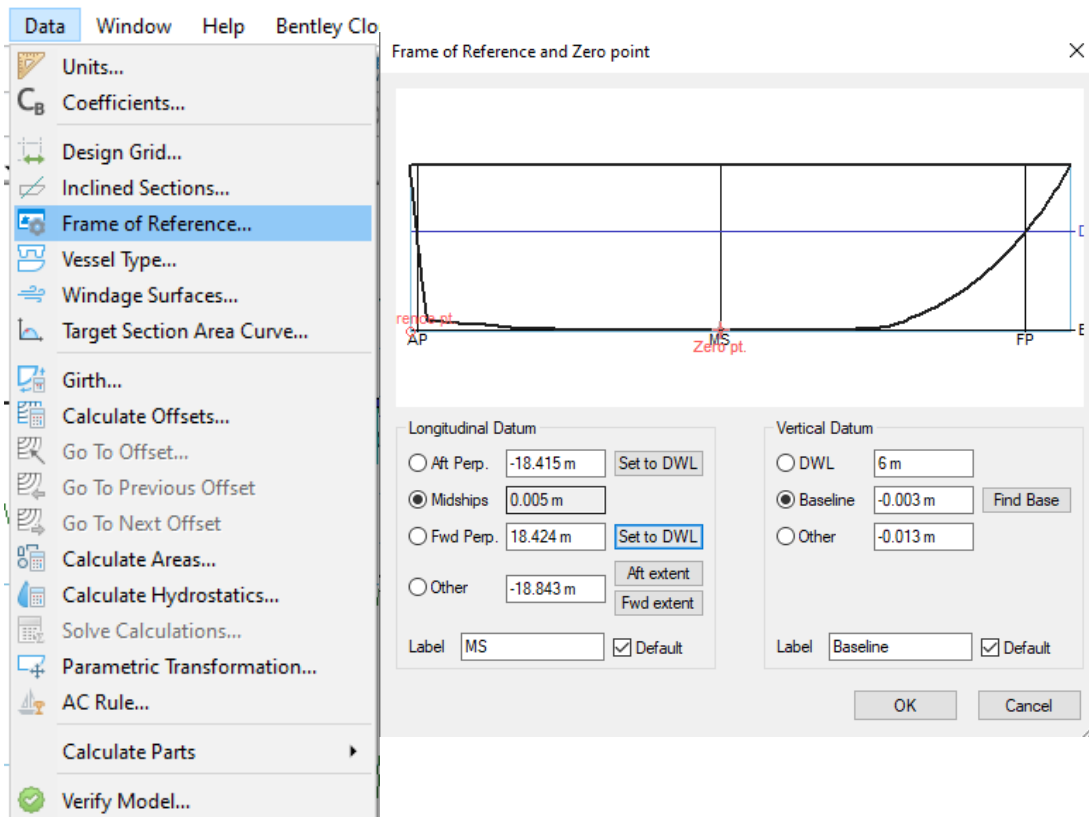

# Multihull vessel (Add and move surfaces)

- Return again to the main hull
- Make sure that the main hull surfaces are locked.
- Go to File → Open design → No → select the outrigger model → Open
- The new outrigger model will be added at the Zero point
  - ✓ Make sure that the net is active
  - ✓ Go to Profile view and move the hull to the desired location
  - ✓ Go to Body plan view and add the hull in the desired transverse location
    - *As the outrigger is symmetric around the main hull center line, only one side of the outrigger can be moved/amended.*

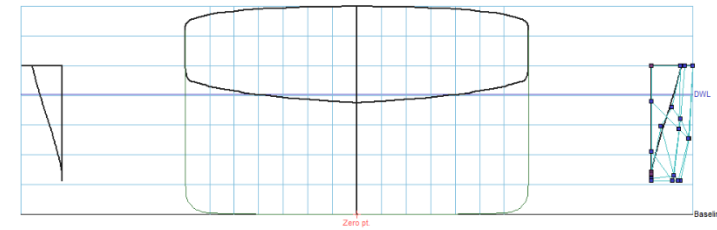

MAXSURF Modeler Advanced CONNECT Edition

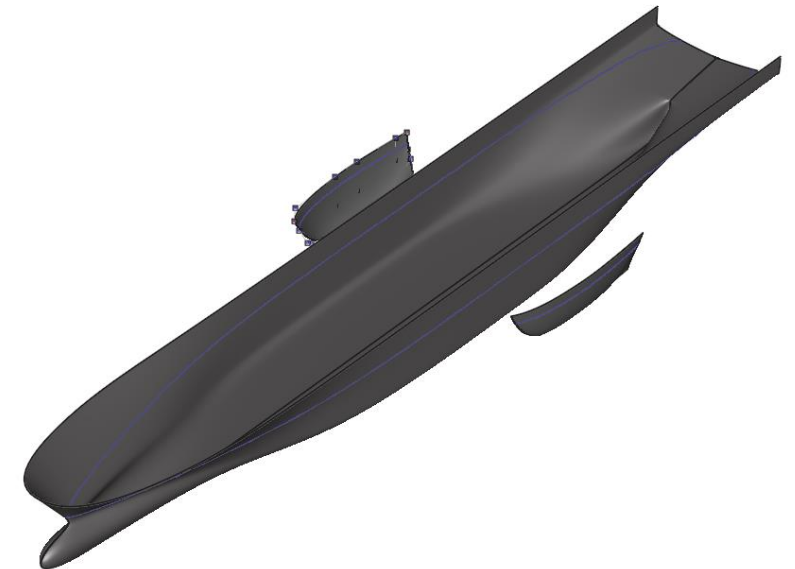
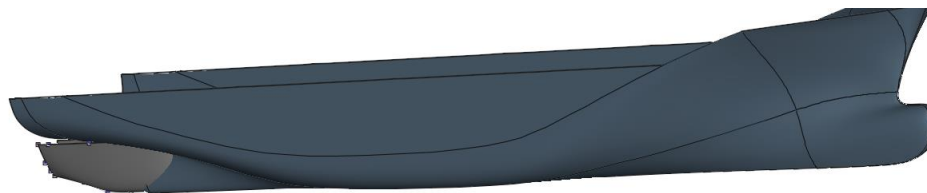
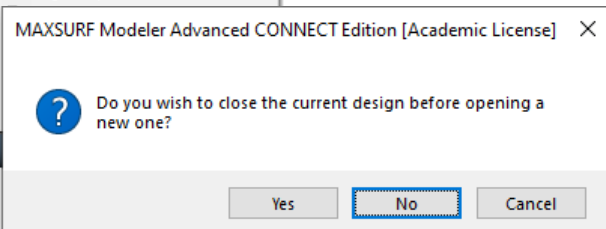
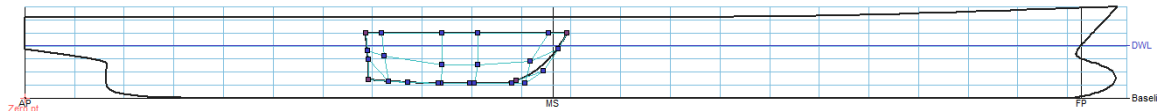
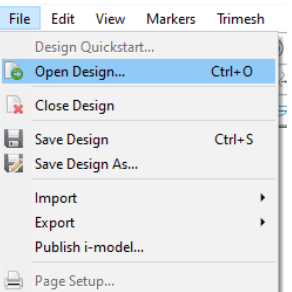

6 ContainerShip\_1Surface.msdl  
7 Ice Breaker5.msdl  
8 F:\2Study\...\Ice Breaker3.msdl

# Multihull vessel (Flip surface)

- **After setting the outrigger CL at the desired transverse location ( here 25 m from main hull center line)**
  - Select the outrigger side → Go to surface → Flip surface → check flip about transverse → enter the transverse location of the Outrigger CL → Check Duplicate → Ok

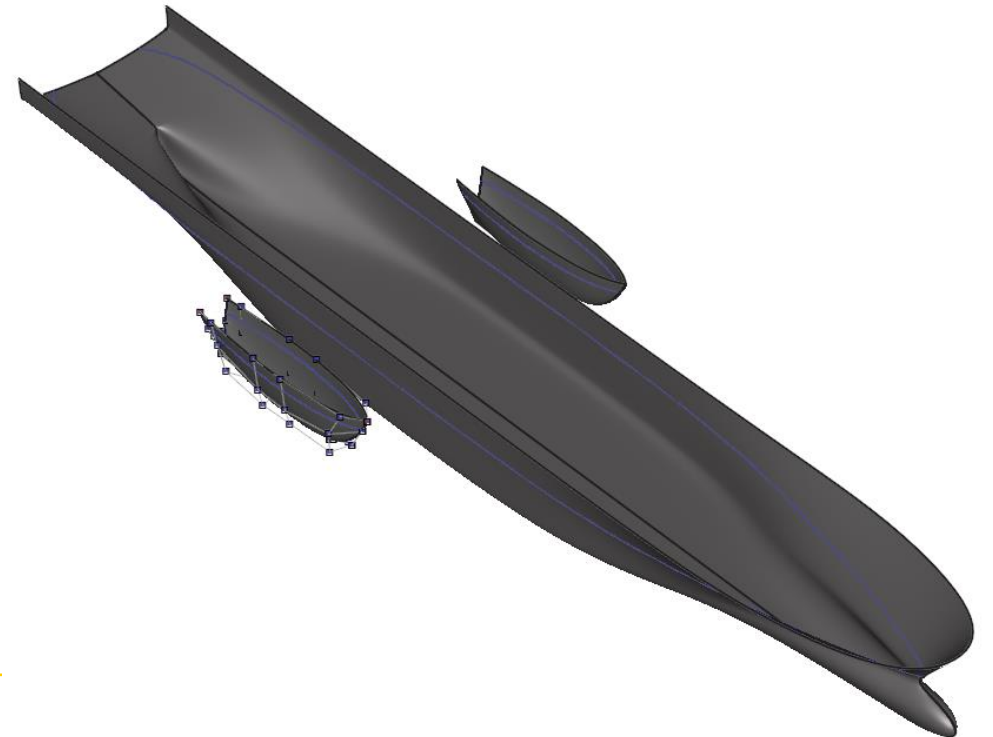
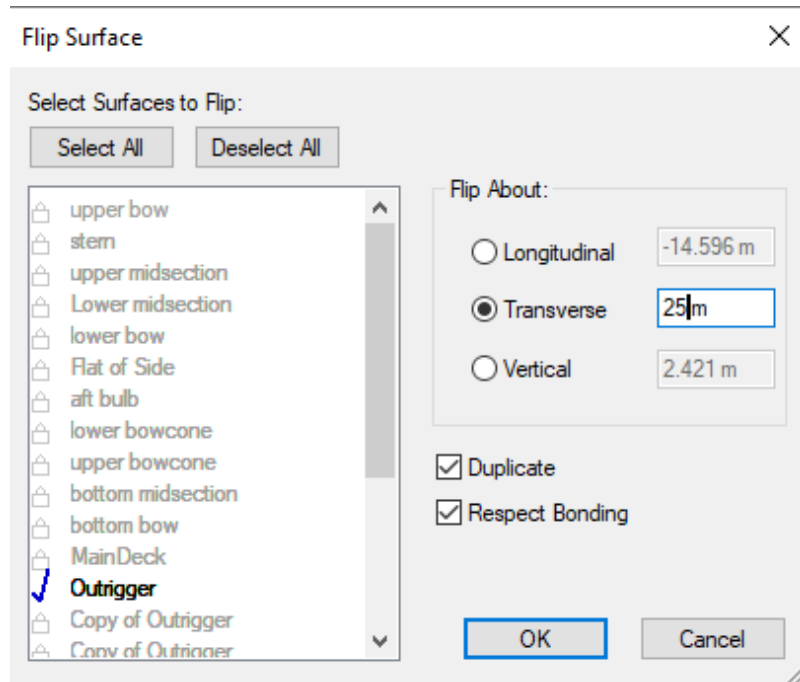
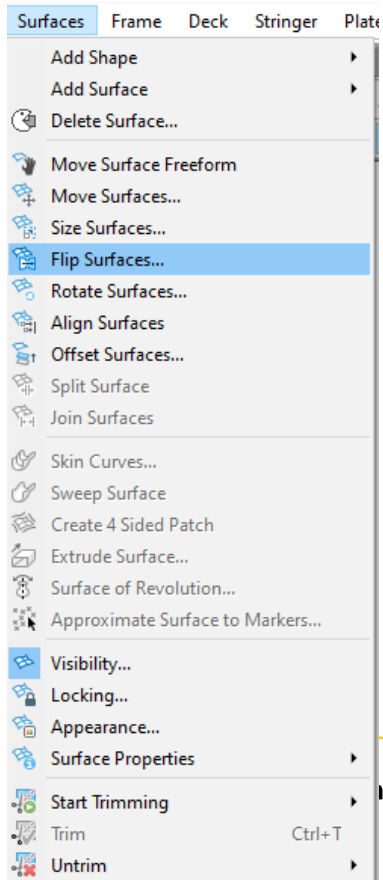

# Multihull vessel (Duplicate surfaces)

- **To add the two aft outrigger:**
  - Select the first outrigger two sides
  - Go to surface → move → enter the longitudinal movement distance → check duplicate → Ok

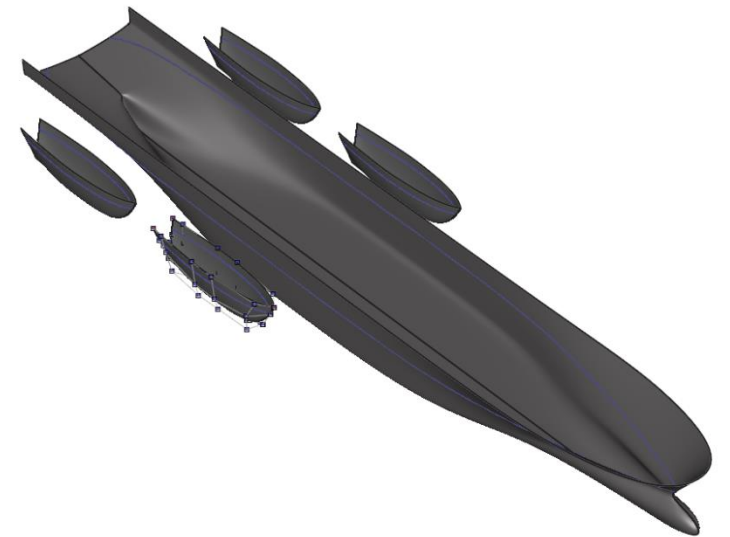
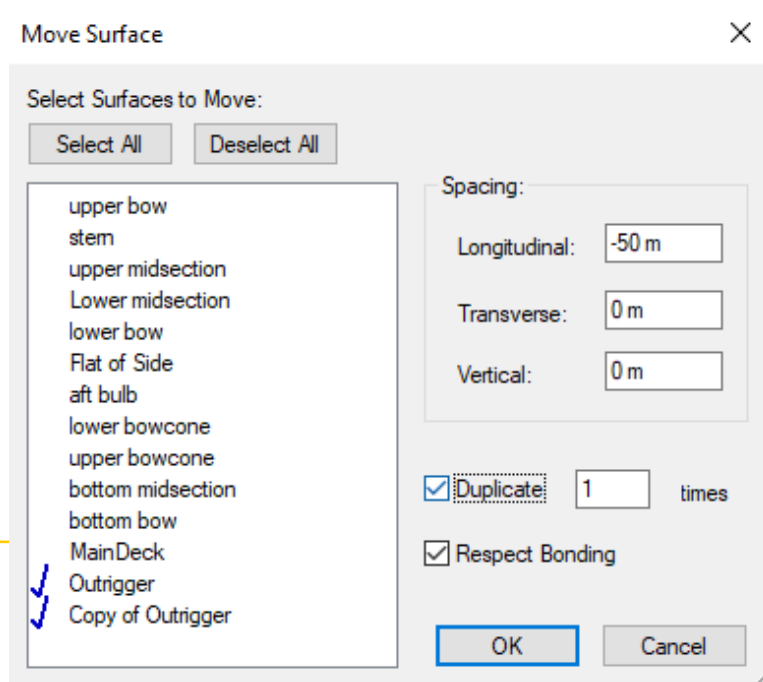
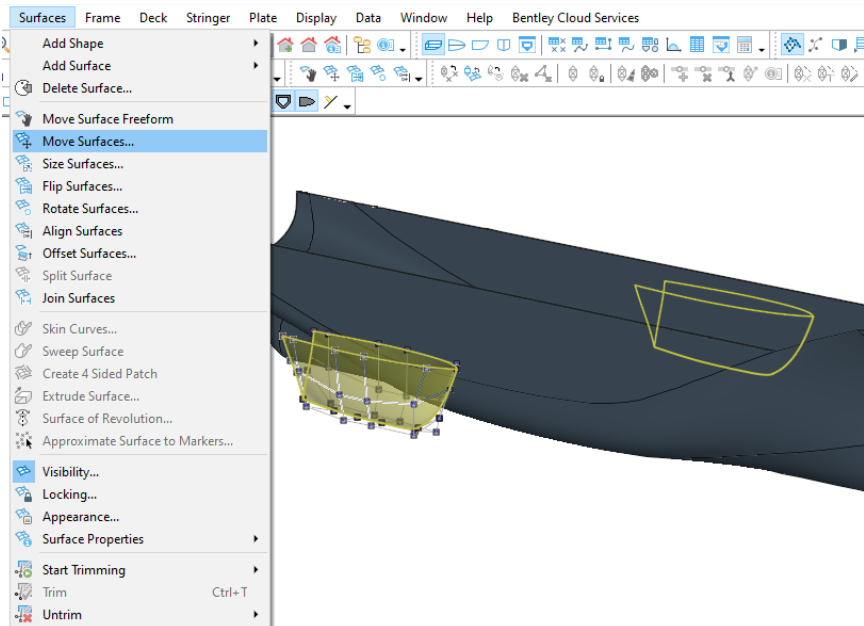

# Multihull vessel (Duplicate surfaces)

- For visual purposes only you can connect the outriggers with the main hull by adding planar surfaces and form them freely into the desired shape

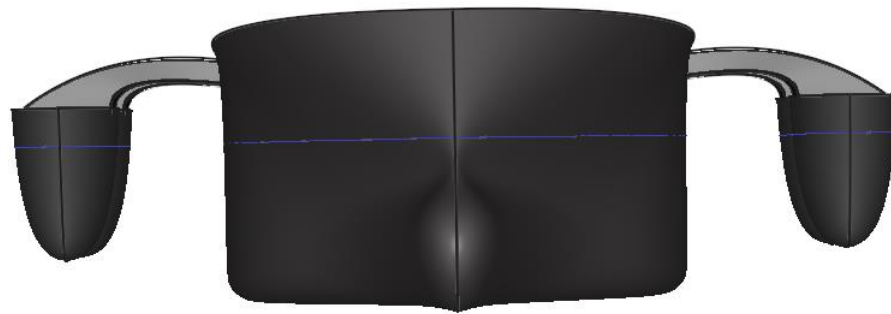



# Multihull vessel (Setting the Vessel Type)

- The vessel type, monohull, catamaran or trimaran, is defined in the Vessel Type dialog.
  - **Data → Vessel Type**
- This information is important for conducting resistance analysis.
- For the monohull vessel type there is nothing more to specify other than that the vessel is a monohull
- In the case of a catamaran, you should specify the offset of the local demihull centerline.
- For trimarans, you must specify the centerline offset location of the outer hull and also the transverse extents of the main hull (half breadth of the main hull body).

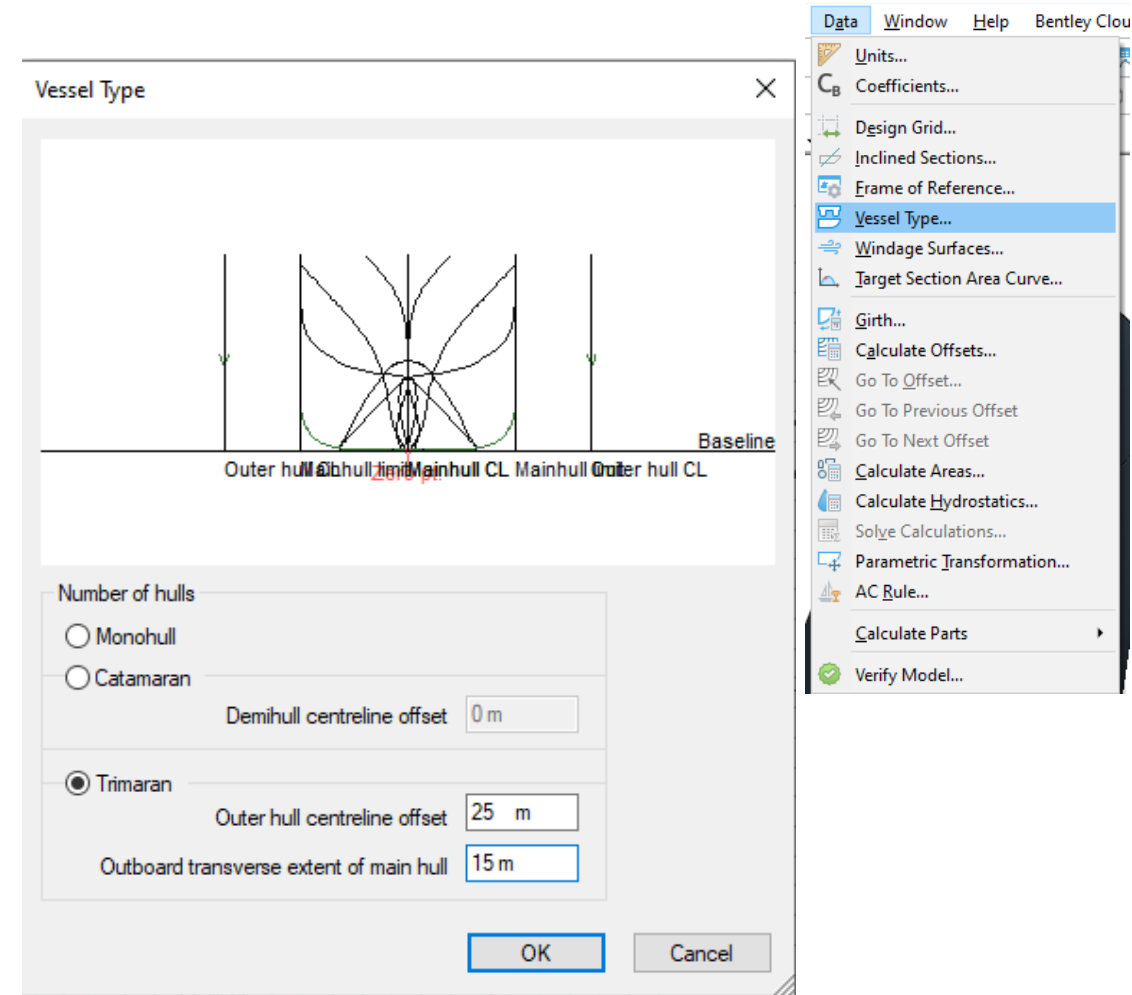

# Multihull vessel (Exporting ship lines)

- To generate lines plan in DXF format from the 3D model Go to the profile view and press
  - File → Export → Lines Plan

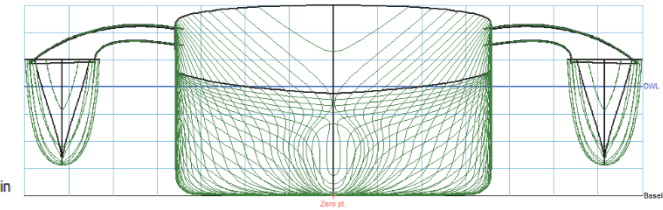
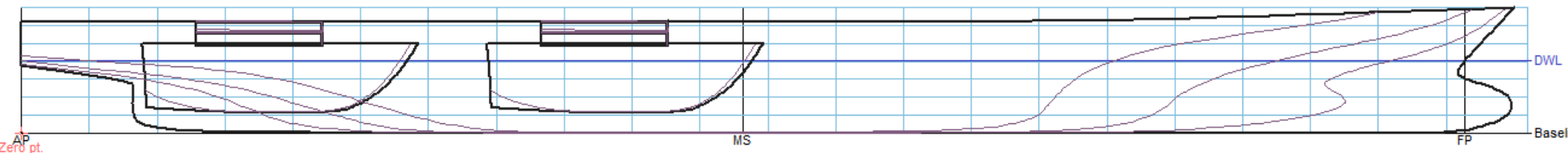
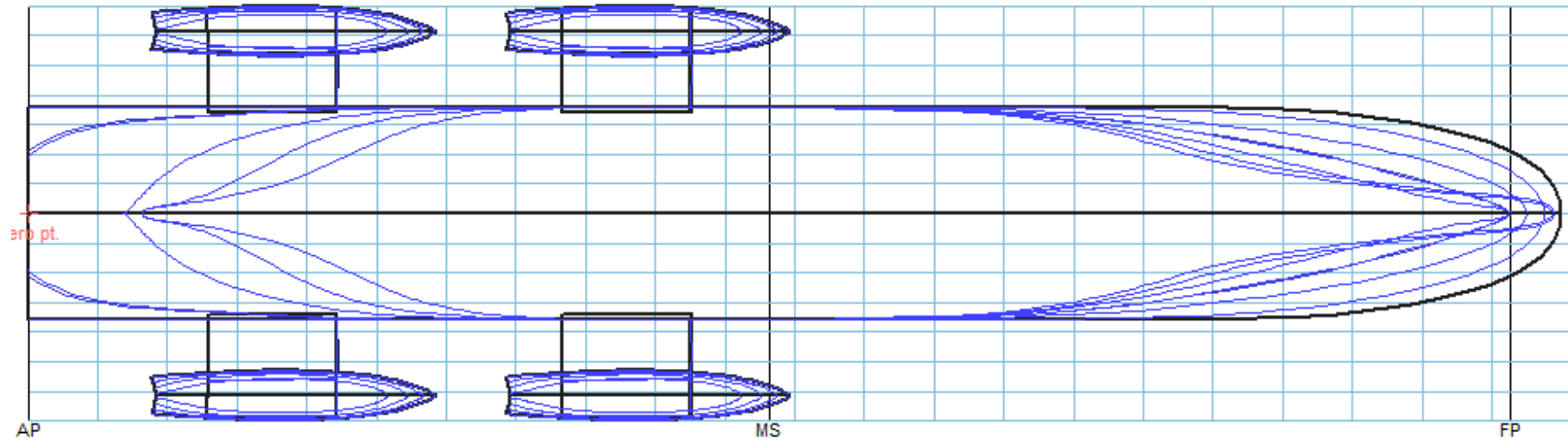



# Hydrostatics

# Hydrostatics

- **Maxsurf Stability can be employed, to plot hydrostatics curves.**
  - Save the model in Maxsurf modeler
  - Open Maxsurf stability
  - Go to File → Open Design → and open the modified model.
  - If it is the first time to open the model in Maxsurf Stability, the first option “read existing data” should not be active (Next time you can select this option to open the saved stability file)
  - From stations, select the appropriate number of stations that will be used to calculate ship hydrostatics. It depends on the ship length and the ship geometry. Increasing the number of stations will increase the required analysis time.

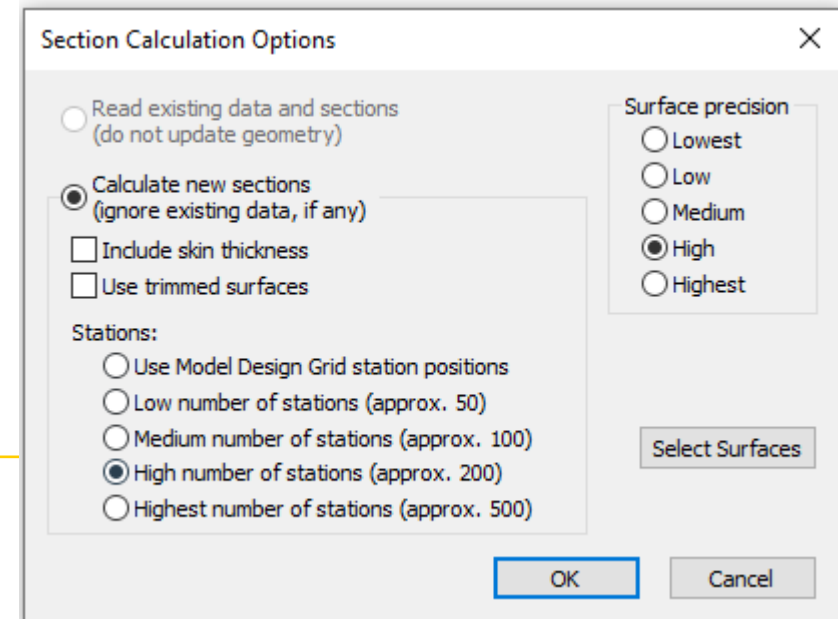
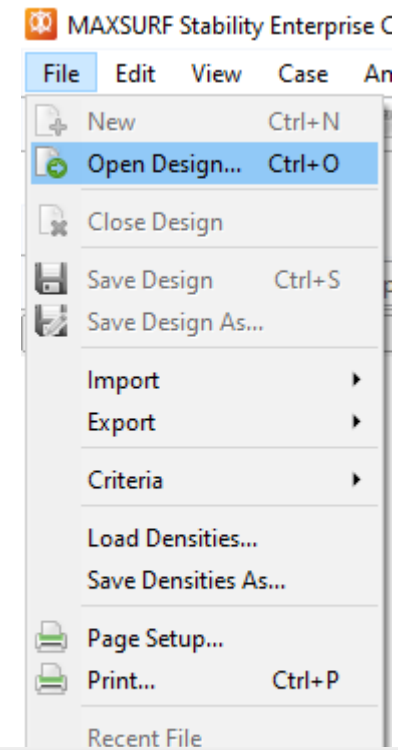

# Hydrostatics

- To show the stations that will be used in hydrostatics calculations
  - Go to Display → Visibility → Sections

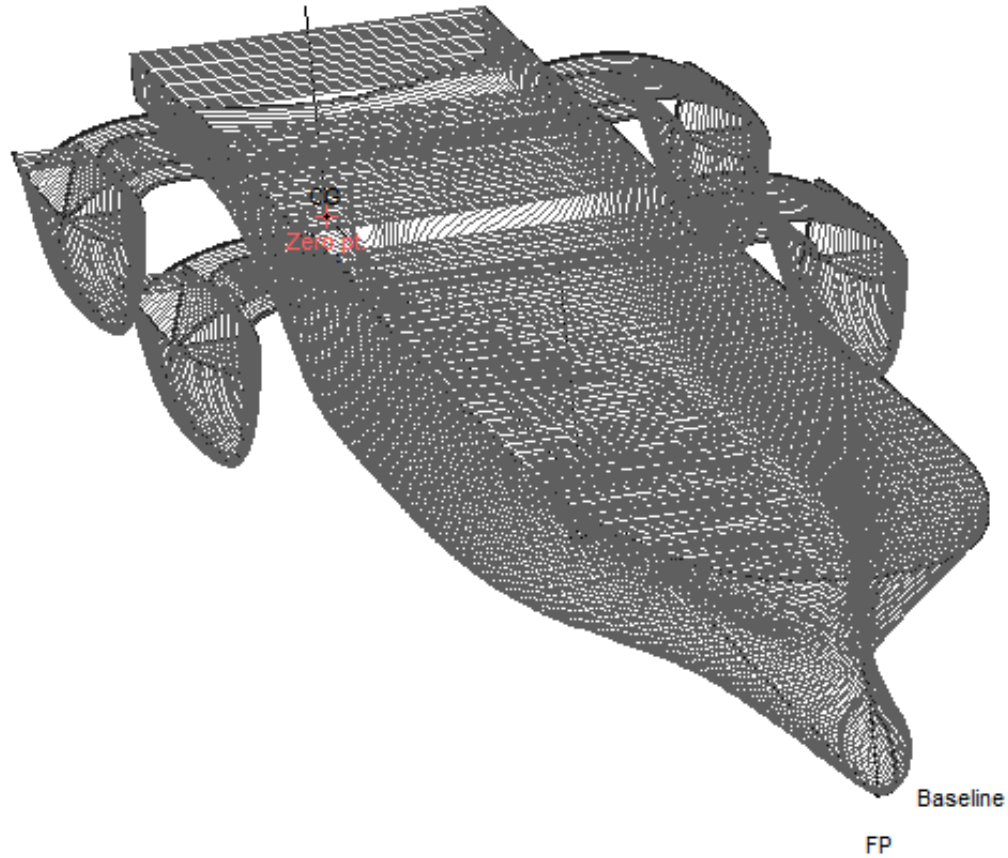

# Hydrostatics

- In case the hull could not be opened in Maxsurf Stability properly, you should remove symmetric option in the Maxsurf Modeler
  - Select all surfaces → uncheck symmetrical in properties window and also uncheck locking → Make sure all surfaces are not symmetric and not locked → Then flip all the surfaces around centerline → select the 2 sides of the main body hull → go to surfaces → join surfaces

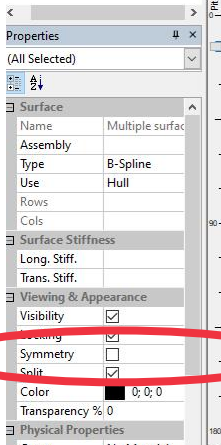
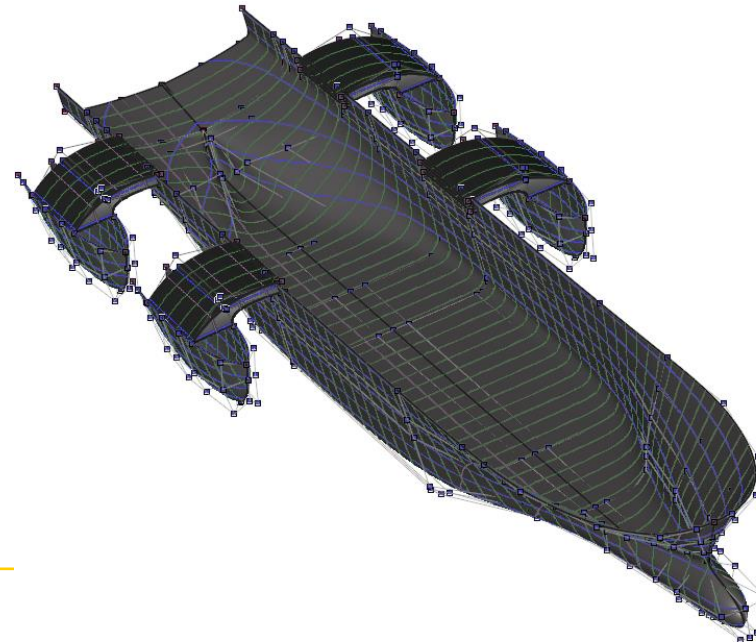
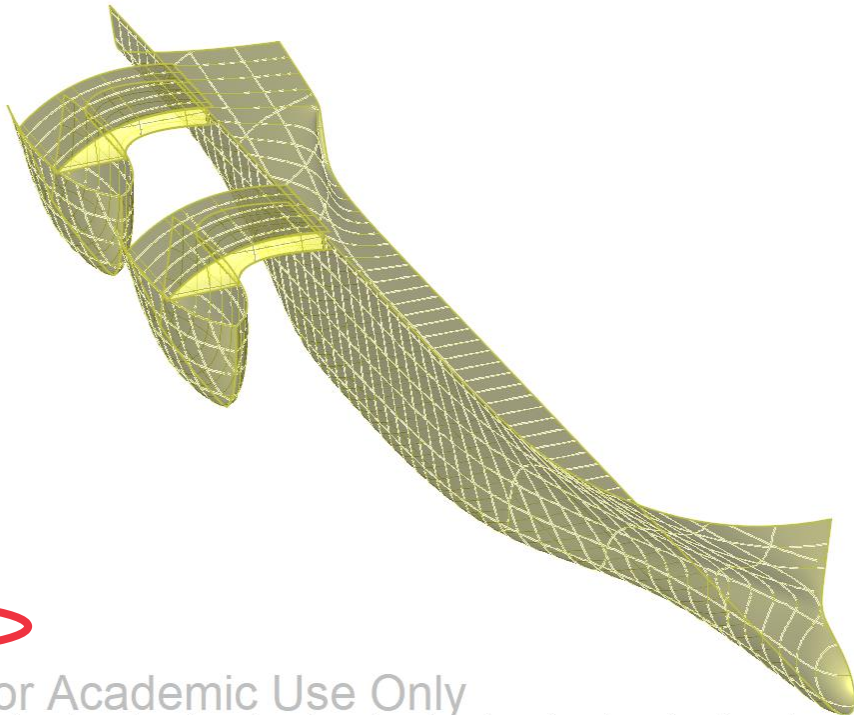
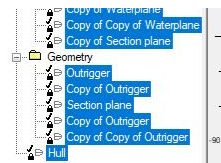

For Academic Use Only

# Hydrostatics

- Now we need to define the range of draft for hydrostatics calculations:
  - Go to window → Upright Hydrostatics (Or select it from Analysis tab)
  - Go to Analysis → Draft..
  - Define initial draft amidship, Final draft and draft increment or number of drafts
  - Define VCG and LCG if available unless the calculations of GM will be not accurate.
  - Press Ok
  - You can instead define range of displacement from Analysis → Displacement..

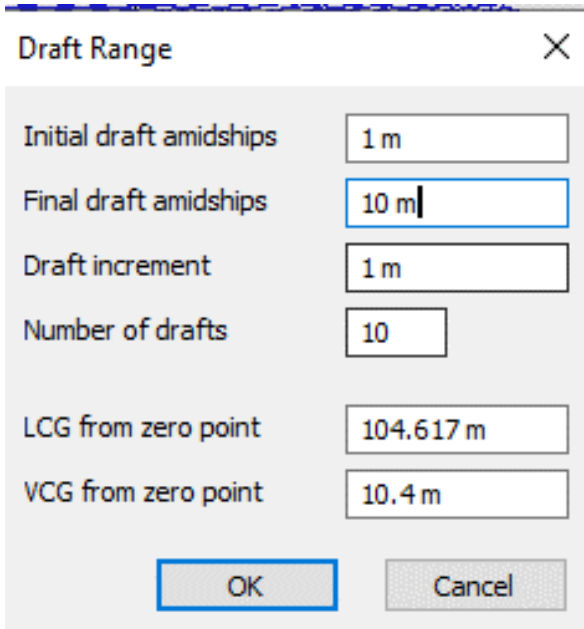
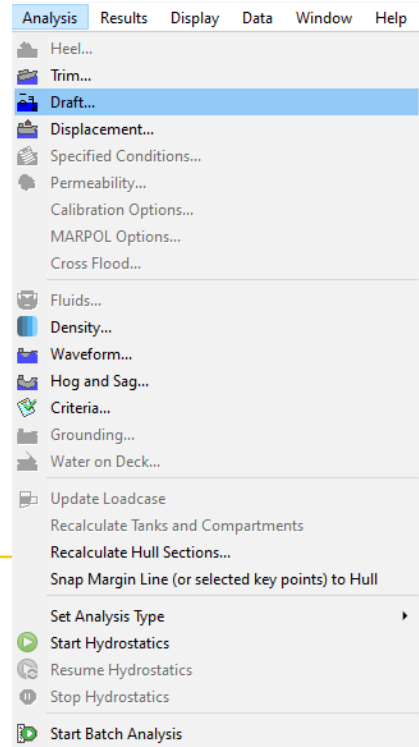
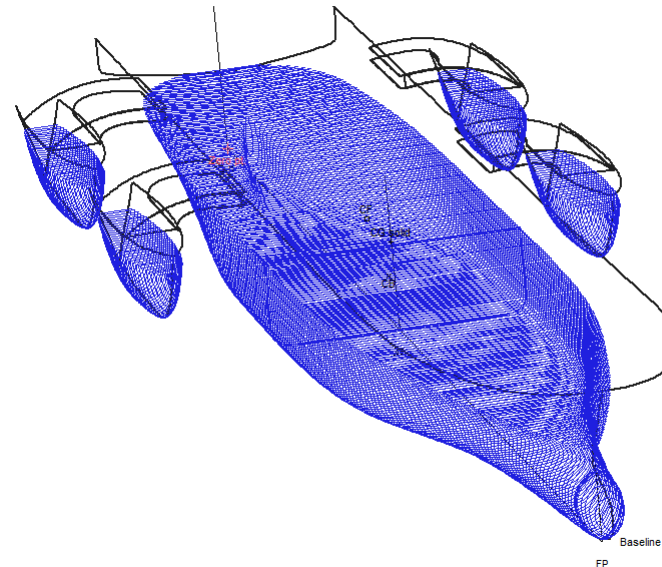
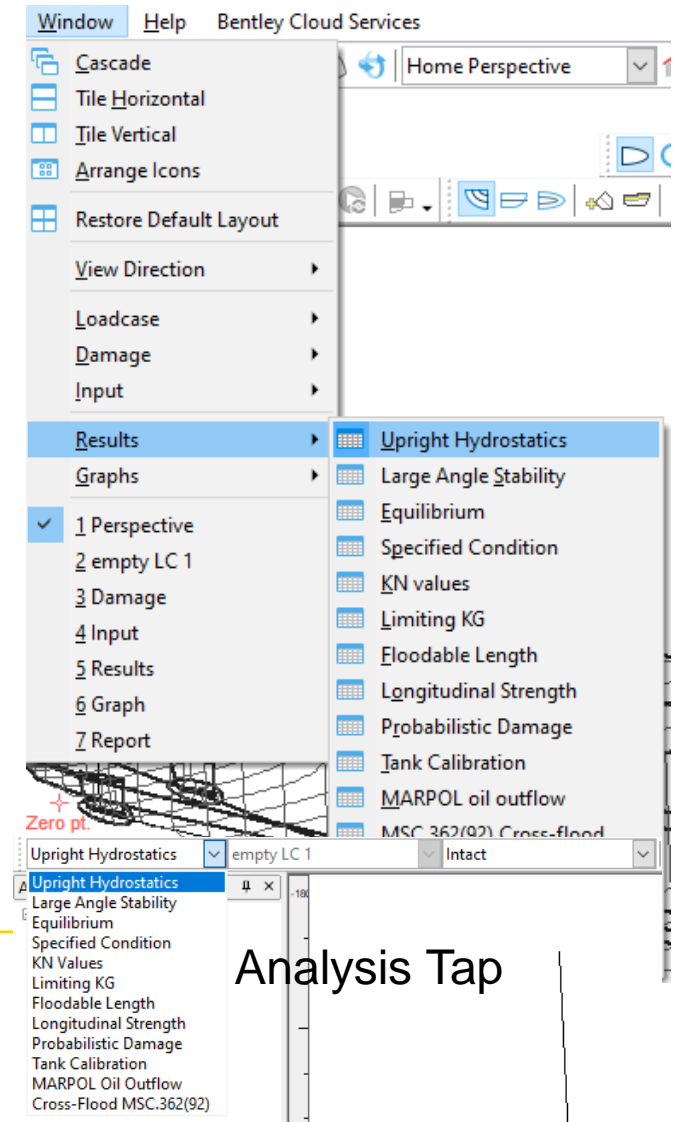



# Hydrostatics (Results)

- To Calculate the hydrostatics Go to Analysis → Start Hydrostatics.
- To show the tabulated results at different drafts:
- Go to Window → Results..

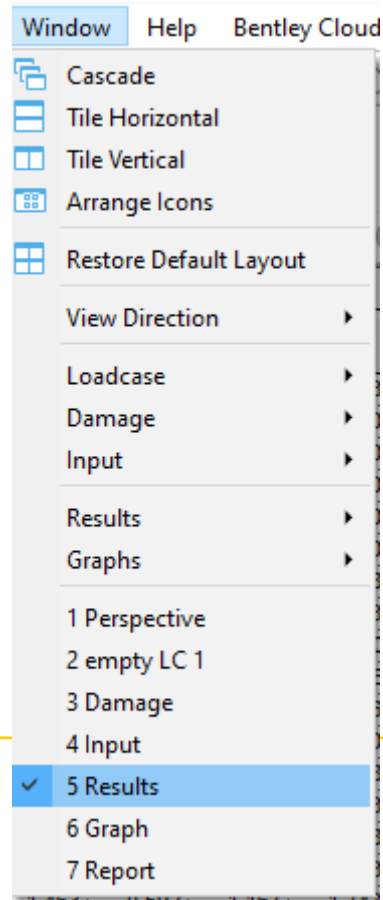
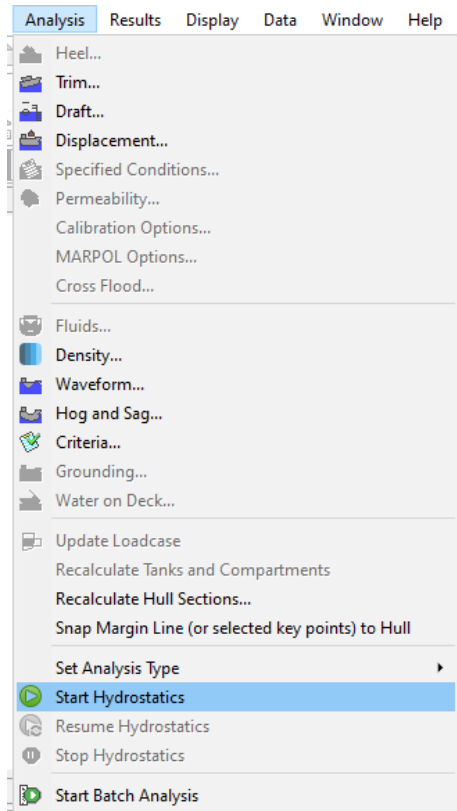

	Draft Amidships m	1.000	2.000	3.000	4.000	5.000	6.000	7.000	8.000	9.000	10.000
1	Displacement t	3056	6763	10704	15001	19594	24403	29400	34611	40140	46064
2	Heel deg	0.0	0.0	0.0	0.0	0.0	0.0	0.0	0.0	0.0	0.0
3	Draft at FP m	1.000	2.000	3.000	4.000	5.000	6.000	7.000	8.000	9.000	10.000
4	Draft at AP m	1.000	2.000	3.000	4.000	5.000	6.000	7.000	8.000	9.000	10.000
5	Draft at LCF m	1.000	2.000	3.000	4.000	5.000	6.000	7.000	8.000	9.000	10.000
6	Trim (+ve by stern) m	0.000	0.000	0.000	0.000	0.000	0.000	0.000	0.000	0.000	0.000
7	WL Length m	193.514	198.035	199.575	199.977	199.568	198.214	195.636	197.101	203.555	208.908
8	Beam max extents on W	29.446	29.929	52.728	55.129	56.145	56.801	57.271	57.625	57.899	58.115
9	Wetted Area m²	3524.877	4047.473	4568.229	5343.512	6076.453	6813.772	7577.970	8388.015	9279.196	10222.36
10	Waterpl. Area m²	3441.230	3750.144	3984.985	4356.061	4594.469	4783.827	4968.400	5221.385	5577.930	5977.487
11	Prismatic coeff. (Cp)	0.554	0.578	0.596	0.594	0.592	0.595	0.603	0.601	0.587	0.580
12	Block coeff. (Cb)	0.523	0.557	0.535	0.489	0.486	0.491	0.502	0.505	0.498	0.496
13	Max Sect. area coeff. (	0.945	0.962	0.901	0.824	0.820	0.826	0.833	0.841	0.848	0.855
14	Waterpl. area coeff. (C	0.604	0.633	0.613	0.582	0.584	0.592	0.609	0.625	0.638	0.660
15	LCB from zero pt. (+ve f	107.648	108.168	108.424	107.823	106.872	105.810	104.659	103.437	102.130	100.748
16	LCF from zero pt. (+ve f	108.284	108.823	108.142	104.935	102.641	100.293	97.796	95.257	92.676	90.250
17	KB m	0.539	1.069	1.598	2.145	2.698	3.251	3.803	4.361	4.932	5.520
18	KG m	10.400	10.400	10.400	10.400	10.400	10.400	10.400	10.400	10.400	10.400
19	BMT m	60.754	31.326	25.052	29.816	28.193	25.884	23.757	21.937	20.397	19.112
20	BML m	1781.526	984.154	712.254	594.299	494.179	416.699	360.520	334.728	337.353	348.985
21	GMt m	50.892	21.996	16.249	21.561	20.490	18.735	17.160	15.898	14.929	14.232
22	GML m	1771.665	974.823	703.451	586.044	486.477	409.550	353.923	328.689	331.885	344.104
23	KMt m	61.292	32.396	26.649	31.961	30.890	29.135	27.560	26.298	25.329	24.632
24	KML m	1782.065	985.223	713.851	596.444	496.877	419.950	364.323	339.089	342.285	354.504
25	Immersion (TPc) tonne/c	35.273	38.439	40.846	44.650	47.093	49.034	50.926	53.519	57.174	61.269
26	MTc tonne.m	258.782	315.067	359.879	420.157	455.567	477.659	497.302	543.717	636.700	757.563
27	RM at 1deg = GMt.Disp.	2714.504	2595.976	3035.582	5644.677	7006.909	7979.109	8804.777	9603.137	10458.35	11441.58
28	Max deck inclination deg	0.0000	0.0000	0.0000	0.0000	0.0000	0.0000	0.0000	0.0000	0.0000	0.0000
29	Trim angle (+ve by stern)	0.0000	0.0000	0.0000	0.0000	0.0000	0.0000	0.0000	0.0000	0.0000	0.0000



# Hydrostatics (Results)

- The graphical representation of the results can be illustrated from:
  - Go to Window → Graph..

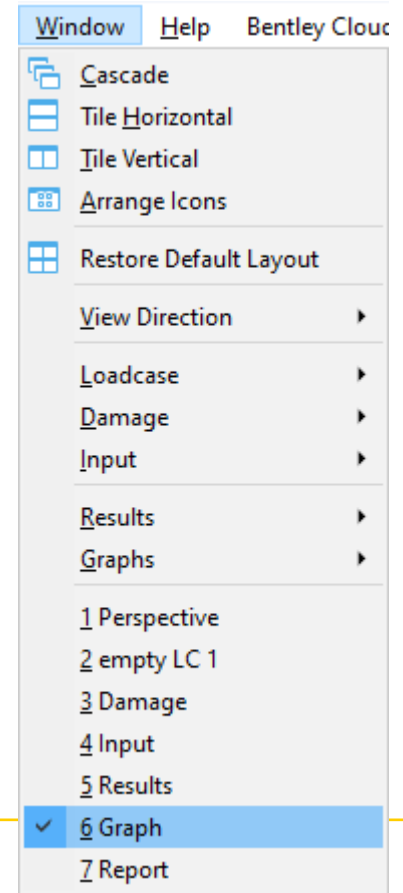
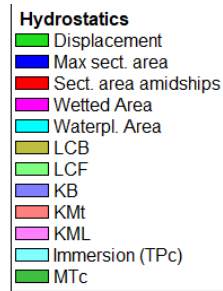
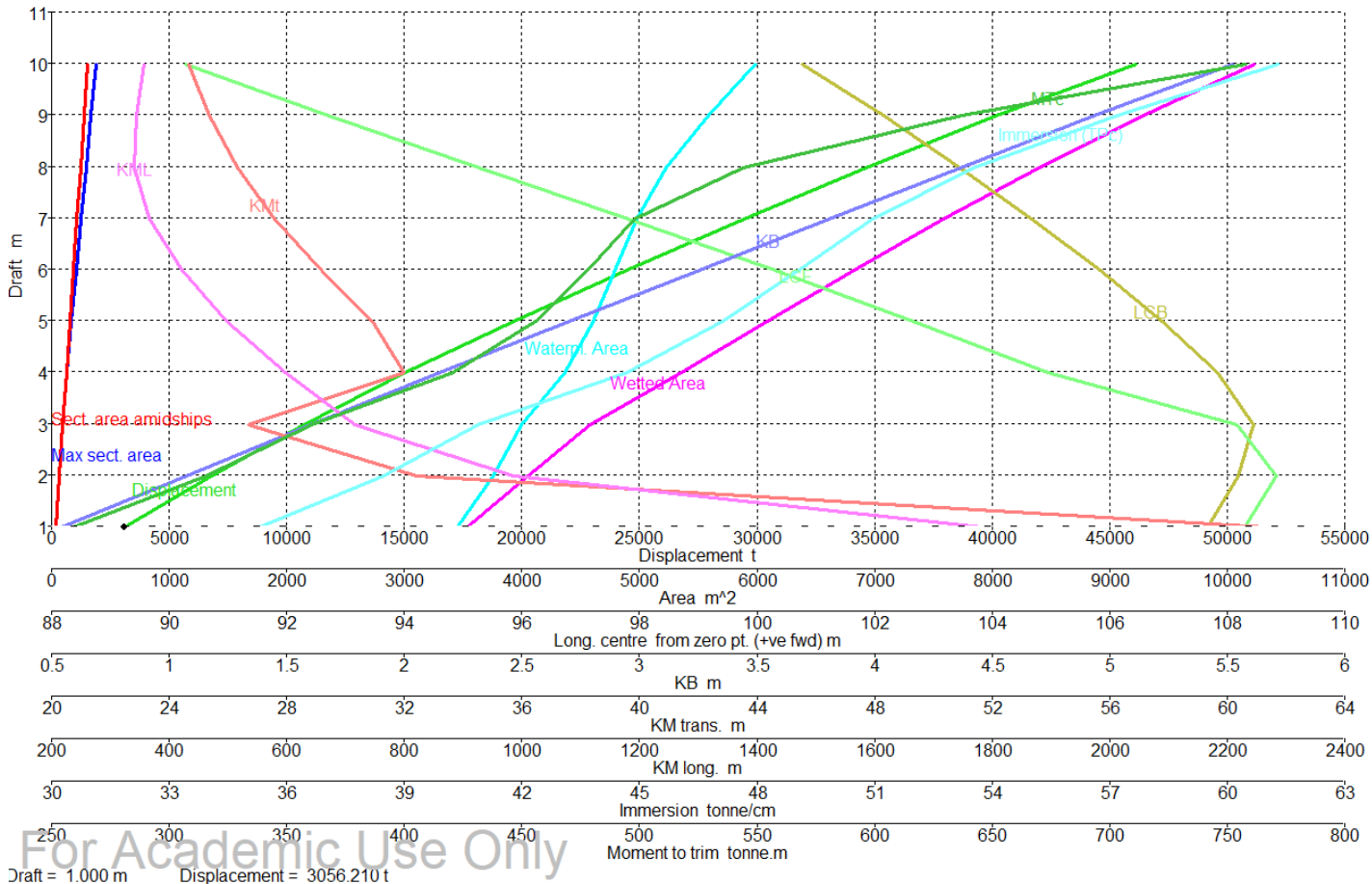

# Hydrostatics (Results)

- The show curves of form, change the type of curves from the tab above the Graph window





# Hydrostatics (Results)

- You can also show the curves of areas and Bonjean curves from the same tab.

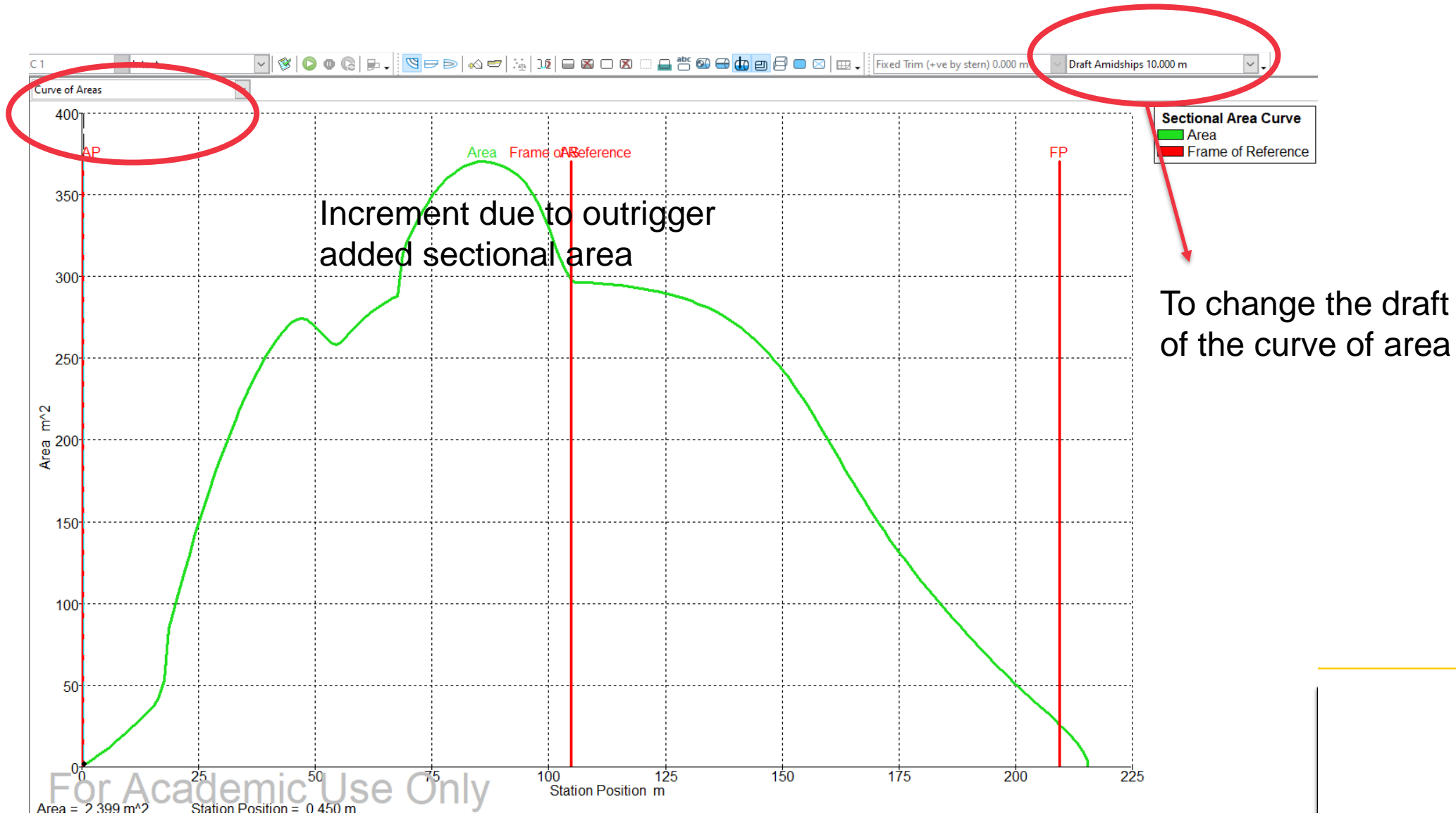

# Hydrostatics (Results)

- Bonjean curves

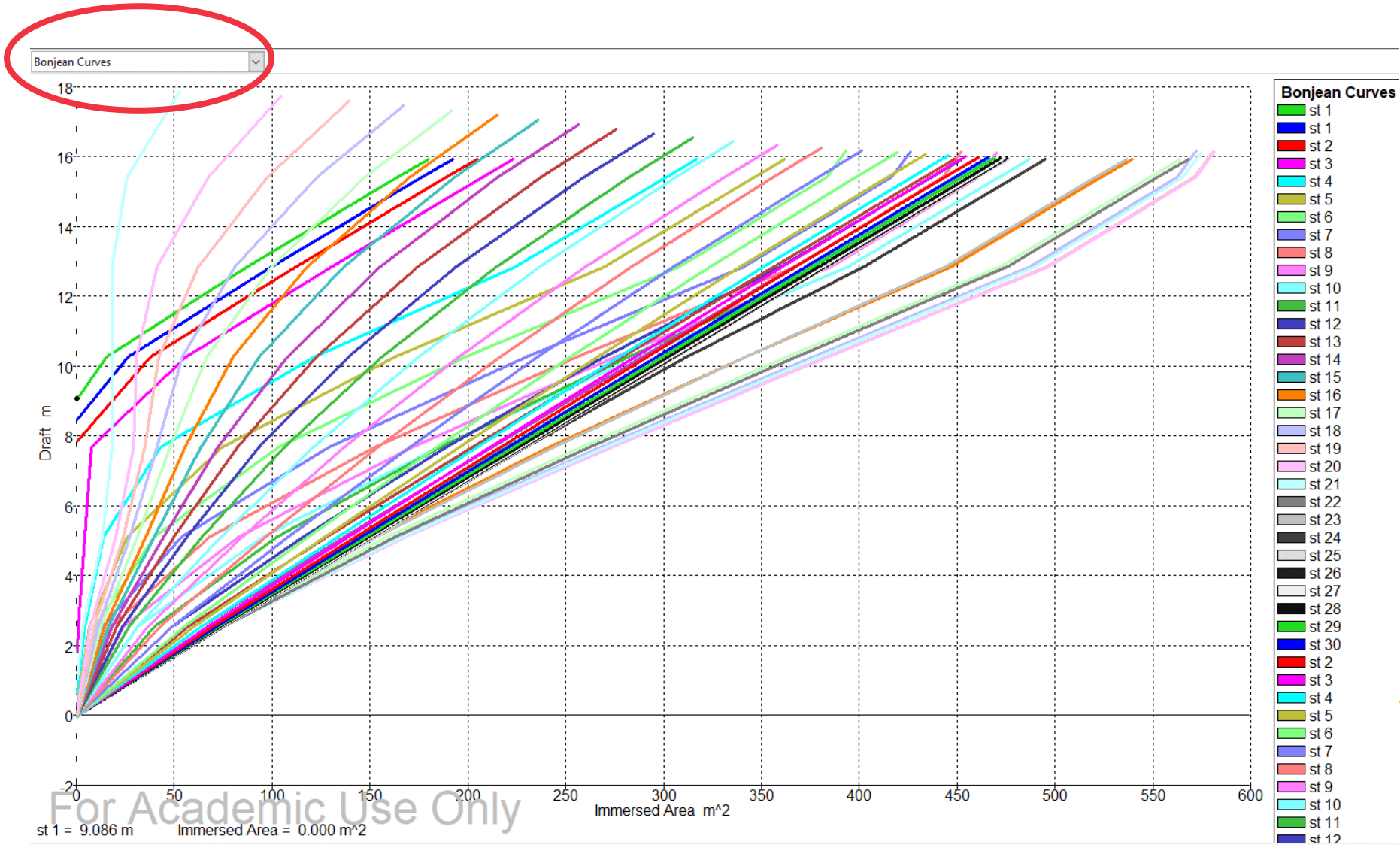

# Catamaran

# Multihull vessel (Catamaran)

- The catamaran or twin-hull vessel consists of two hull arranged in the same direction separated from each other and attached by a common deck.
  - If the two hulls are symmetric, we will only need to model one of them.
- Staggered arrangement of the hulls in their longitudinal placement, allowing one hull to overlap or lead the other by a distance that is preconceived to produce a wave cancellation on the lagging hull.
  - In this case the symmetric option of the surfaces should be unchecked from the surface properties window

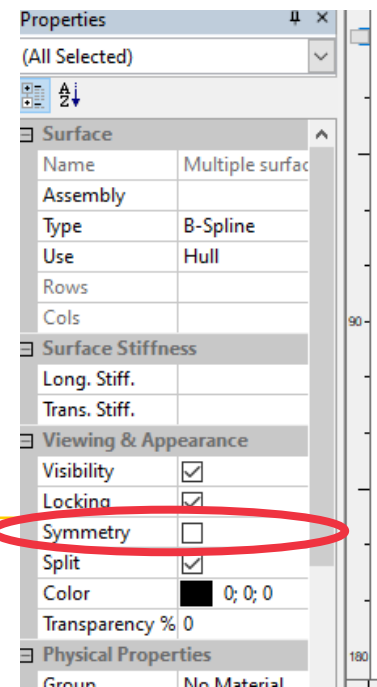

# Multihull vessel (Catamaran)

- The deck of the Catamaran can be modeled separately and then the hulls can be added.
- For sake of simplification, in this presentation, the deck is assumed has a box shape:
  - Open Maxsurf Modeler
  - Surfaces → Add shape → Box
  - Define the Box (buoyant deck structure) main dimensions → check close ends and symmetrical on centerline
  - Define zero point.

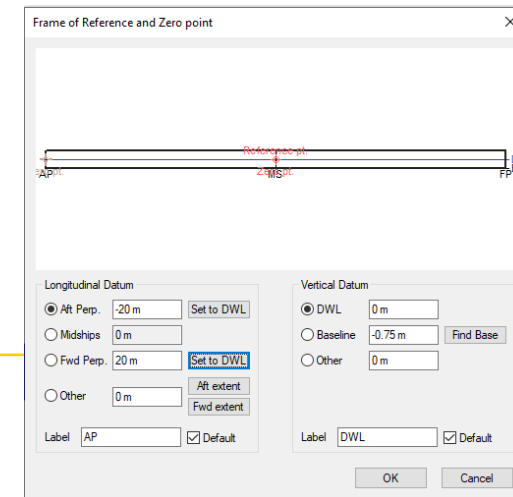
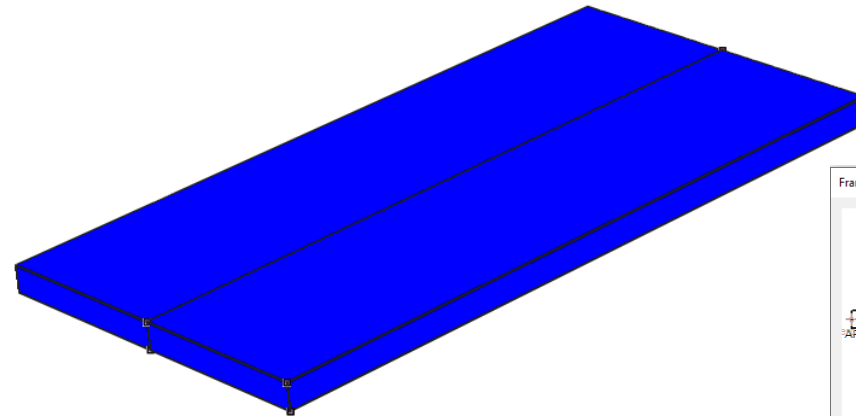
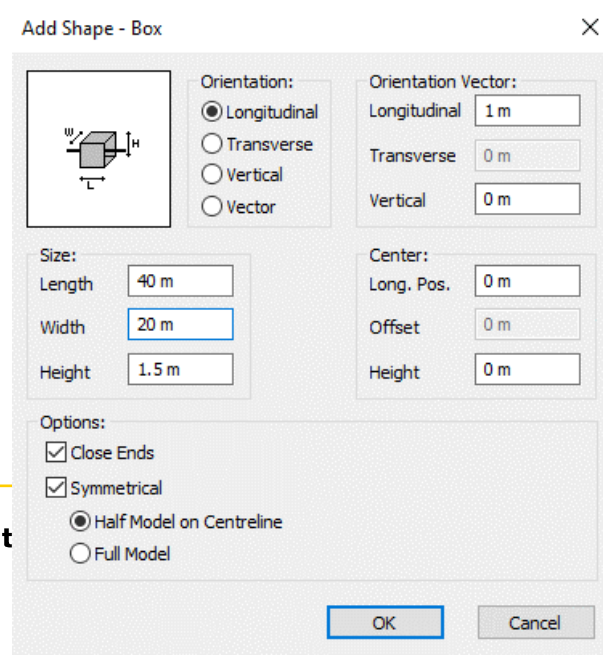
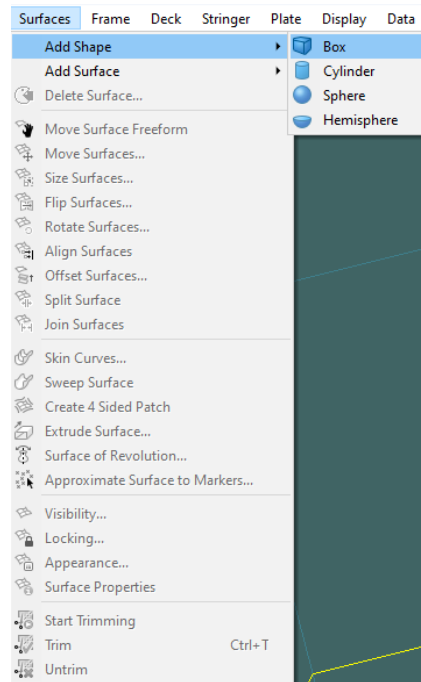

# Multihull vessel (Catamaran)

- **Create 3D model of one of the catamaran hulls**
  - You can use the same method of the outrigger designed previously
  - Also you can use one of the methods described in the previous modeling presentations.
- **Lock all the surfaces of the deck structure.**
- **Import the single catamaran hull into the Maxsurf modeler deck file:**
  - Go to File → Open design → No → select the catamaran single hull → Open

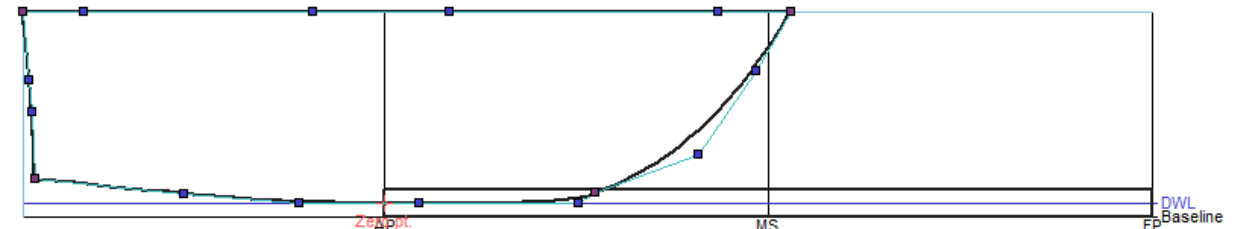
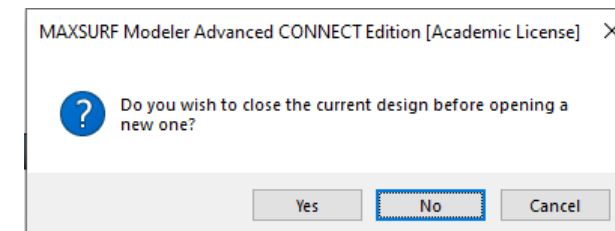
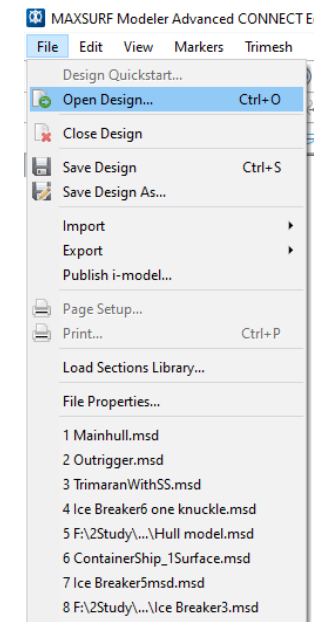

# Multihull vessel (Catamaran)

- **Move the imported outrigger to its desired location.**
  - ✓ Make sure surface Net is active select all control points → Move surface freely
- **Lock all the surfaces of the deck structure.**
- **Import the single catamaran hull into the Maxsurf modeler deck file:**
  - Go to File → Open design → No → select the catamaran single hull → Open

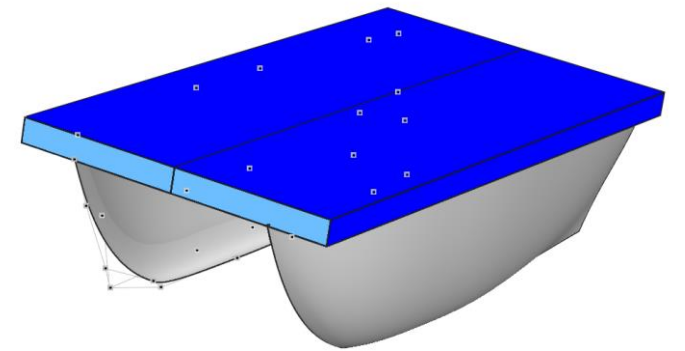
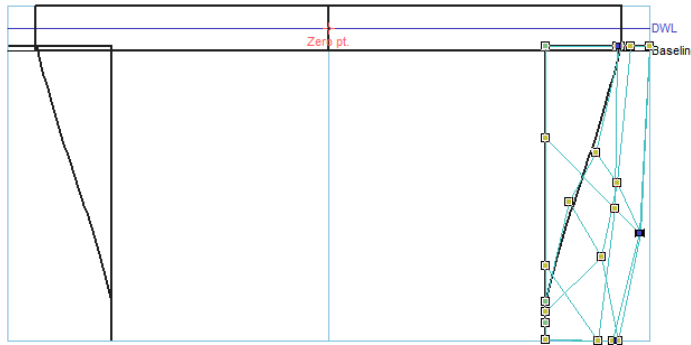
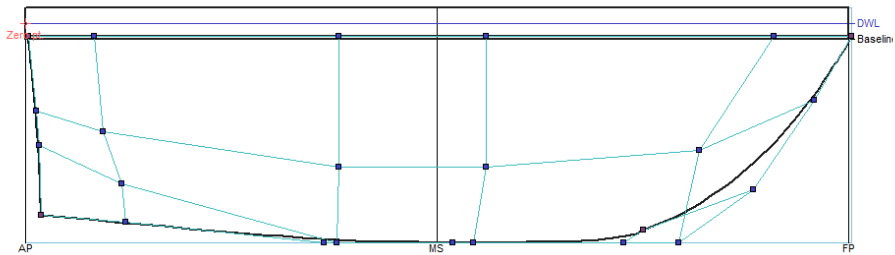

# Multihull vessel (Catamaran)

- After setting the outrigger CL at the desired transverse location, now we can mirror it about its CL
  - Select the outrigger side → Go to surface → Flip surface → check flip about transverse → enter the transverse location of the Outrigger CL → Check Duplicate → Ok

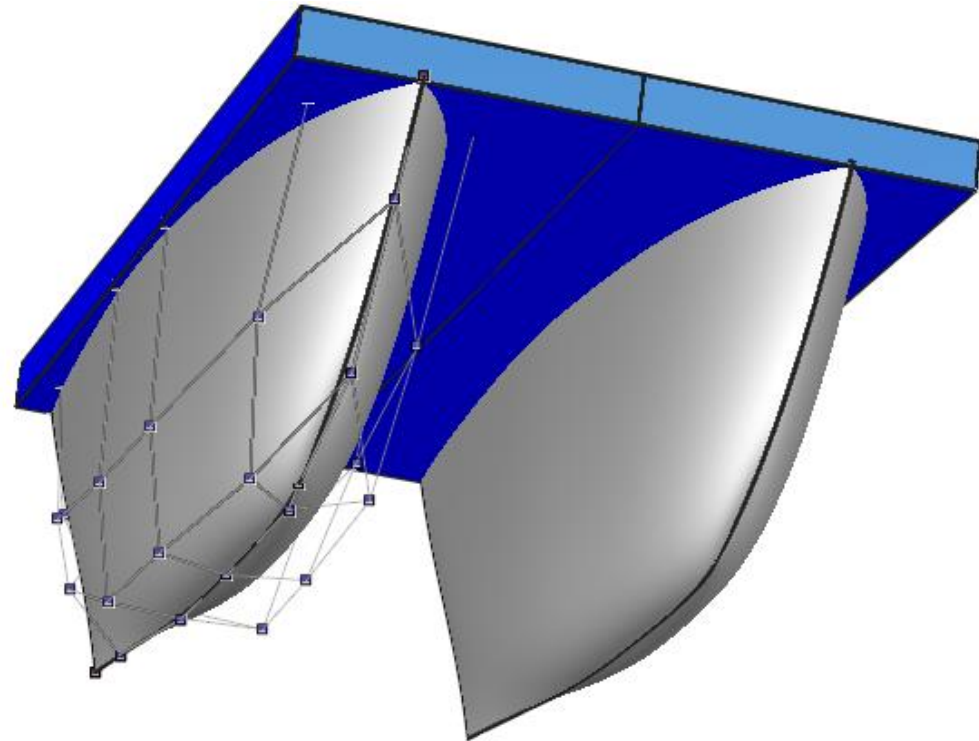
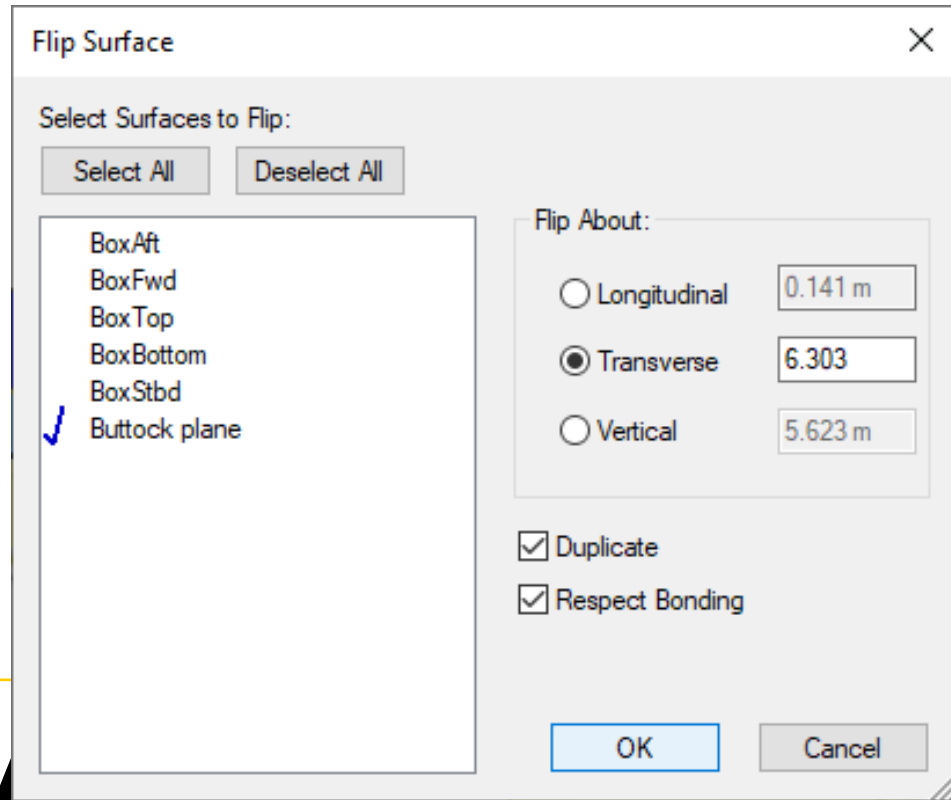



# Multihull vessel (Catamaran)

- After obtaining the desired Catamaran hull form, Add design grid (stations, buttocks and waterlines), define the zero reference point, DWL , perpendiculars and ship type as described previously.

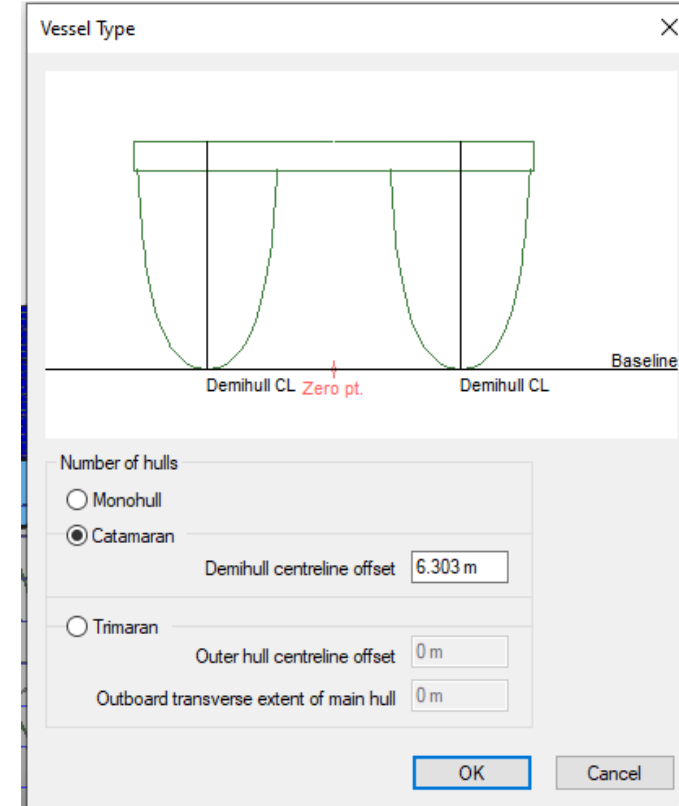
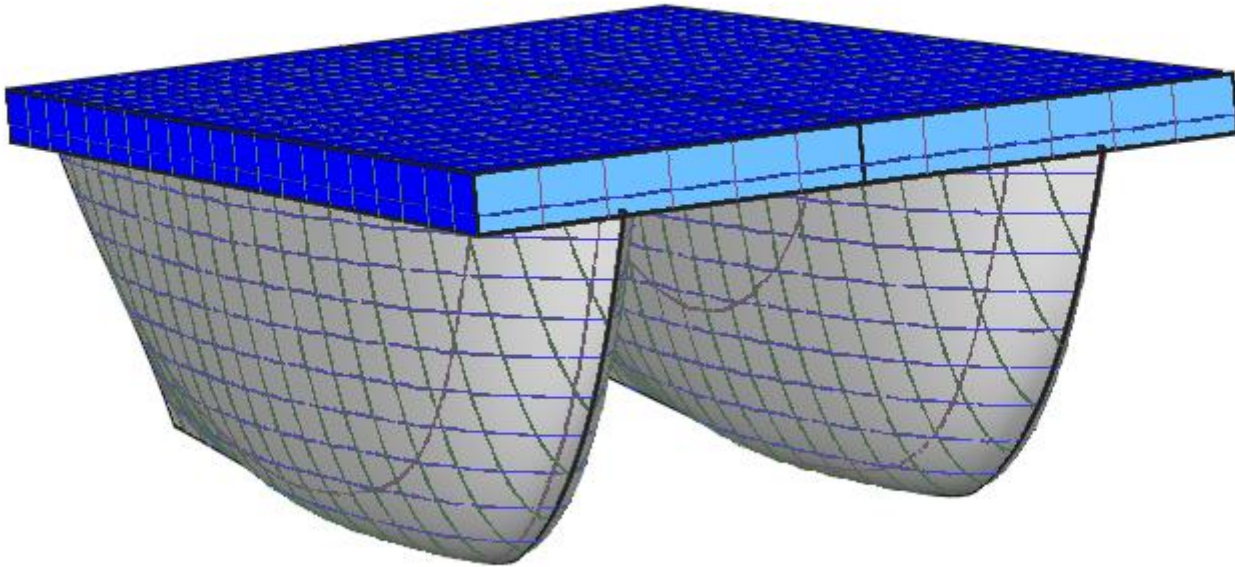

# Catamaran Hydrostatics

# Hydrostatics

- To get the hydrostatics of the Catamaran, follows the same procedures applied early
  - Save the model in Maxsurf modeler
  - Open Maxsurf stability
  - Go to File → Open Design → and open the modified model.
  - If it is the first time to open the model in Maxsurf Stability, the first option “ read existing data” should not be active (Next time you can select this option to open the saved stability file)
  - From stations, select the appropriate number of stations that will be used to calculate ship hydrostatics. It depends on the ship length and the ship geometry. Increasing the number of stations will increase the required analysis time.

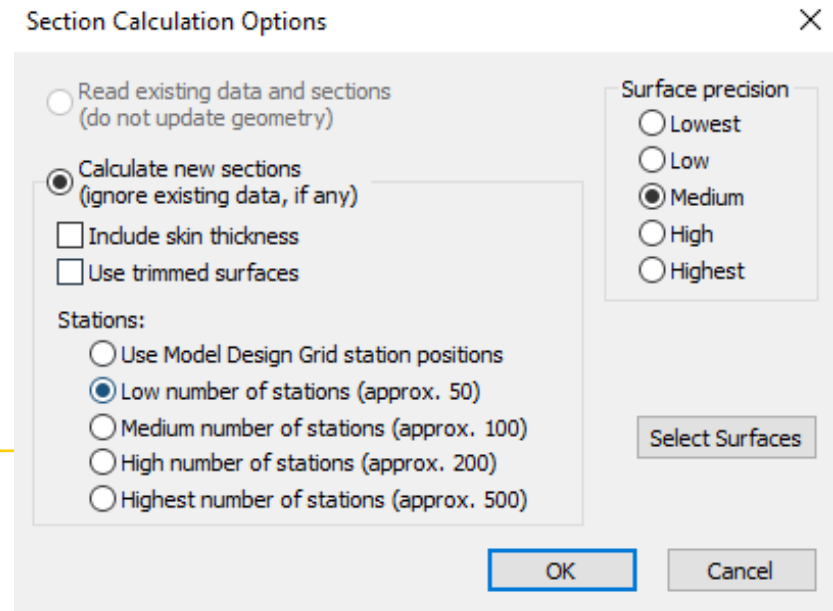
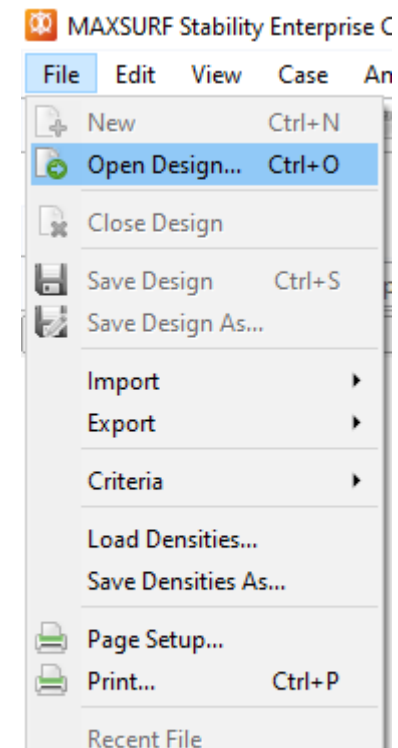

# Hydrostatics

- To show the stations that will be used in hydrostatics calculations
  - Go to Display → Visibility → Sections

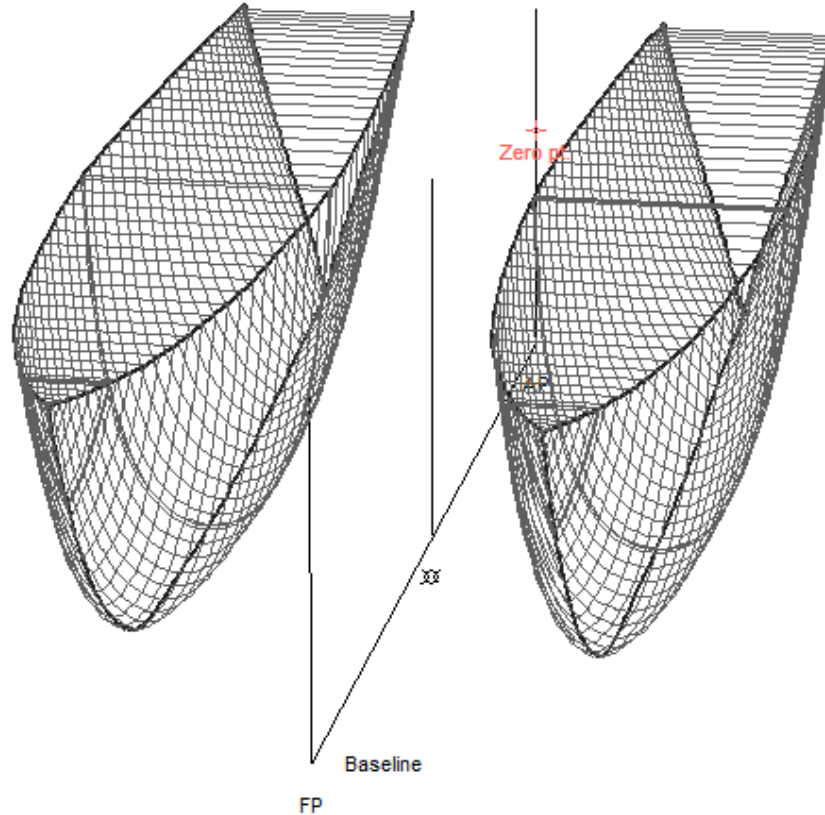

# Hydrostatics

- Now we need to define the range of draft for hydrostatics calculations:
  - Go to window → Upright Hydrostatics (Or select it from Analysis tab)
  - Go to Analysis → Draft..
  - Define initial draft amidship, Final draft and draft increment or number of drafts
  - Define VCG and LCG if available unless the calculations of GM will be not accurate.
  - Press Ok
  - You can instead define range of displacement from Analysis → Displacement..

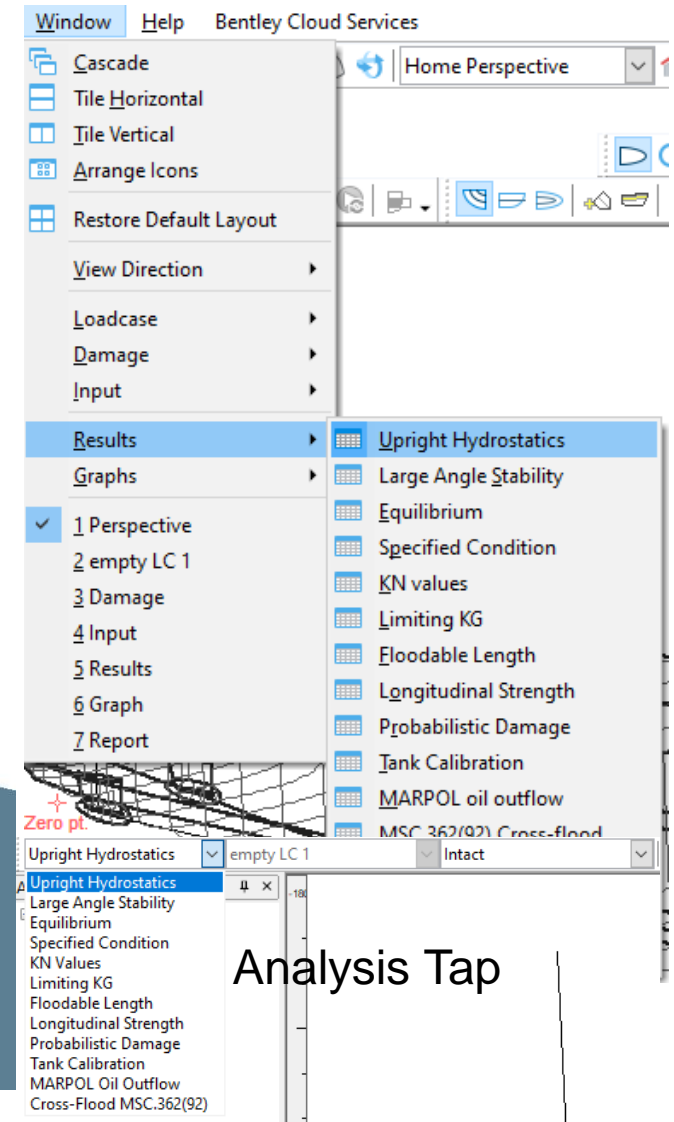

**Draft Range** [X]

Initial draft amidships:

Final draft amidships:

Draft increment:

Number of drafts:

LCG from zero point:

VCG from zero point:

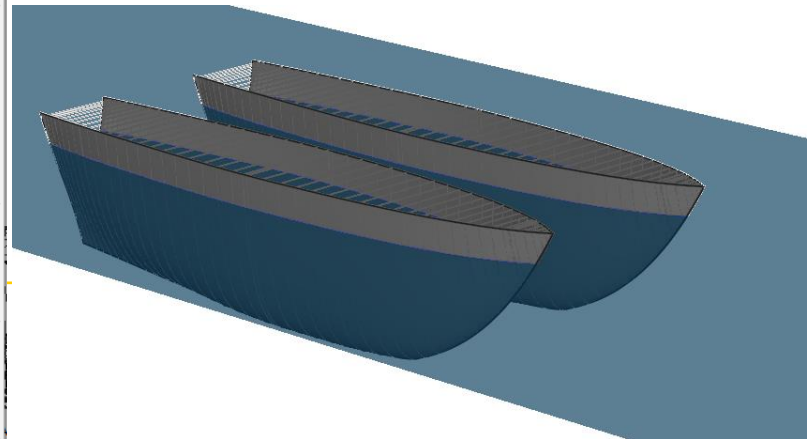
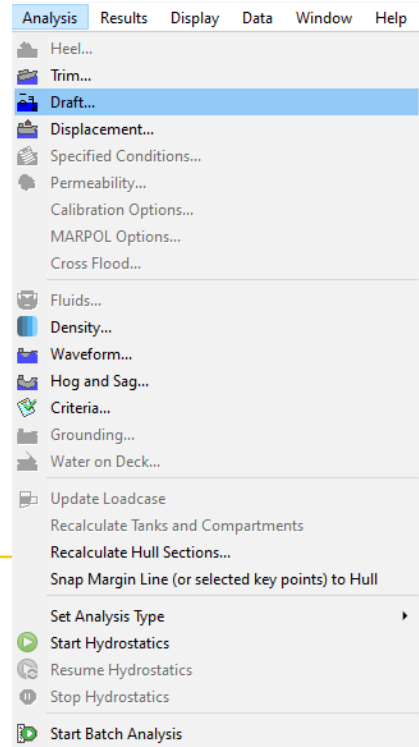

Analysis Tap

# Hydrostatics (Results)

- To Calculate the hydrostatics Go to Analysis → Start Hydrostatics.
- To show the tabulated results at different drafts:
- Go to Window → Results..

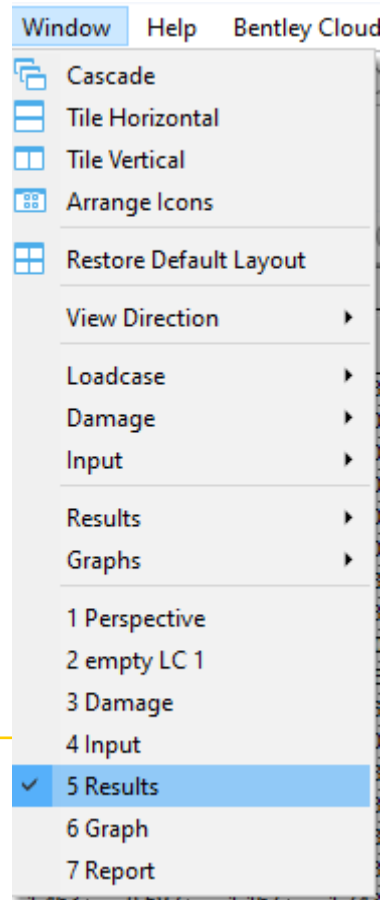
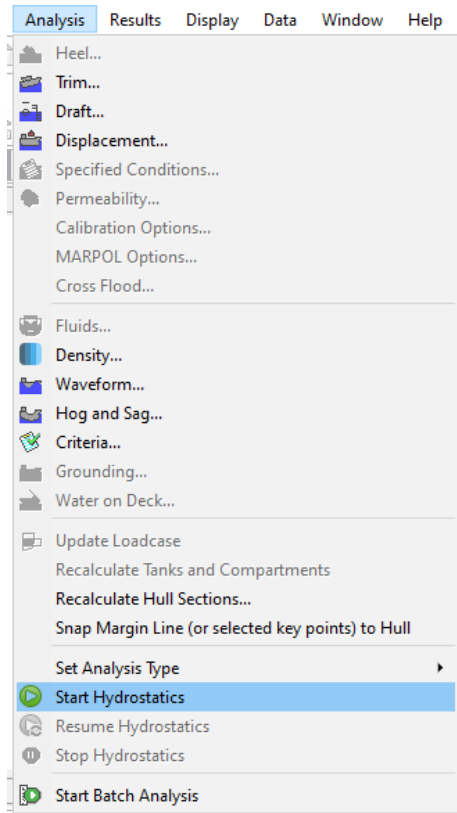

	Draft Amidships m	1.000	2.000	3.000	4.000	5.000	6.000	7.000	8.000
1	Displacement t	71.50	239.7	475.3	761.8	1089	1448	1836	2247
2	Heel deg	0.0	0.0	0.0	0.0	0.0	0.0	0.0	0.0
3	Draft at FP m	1.000	2.000	3.000	4.000	5.000	6.000	7.000	8.000
4	Draft at AP m	1.000	2.000	3.000	4.000	5.000	6.000	7.000	8.000
5	Draft at LCF m	1.000	2.000	3.000	4.000	5.000	6.000	7.000	8.000
6	Trim (+ve by stern) m	0.000	0.000	0.000	0.000	0.000	0.000	0.000	0.000
7	WL Length m	26.737	32.157	33.632	34.854	35.917	36.867	37.734	38.536
8	Beam max extents on W	16.033	17.104	17.787	18.273	18.639	18.921	19.143	19.321
9	Wetted Area m²	149.009	296.269	441.713	588.896	739.754	880.021	1032.621	1188.343
10	Waterpl. Area m²	122.560	200.431	256.500	300.172	336.043	365.167	390.162	411.655
11	Prismatic coeff. (Cp)	0.551	0.570	0.614	0.640	0.657	0.668	0.676	0.682
12	Block coeff. (Cb)	0.381	0.404	0.444	0.470	0.490	0.506	0.519	0.529
13	Max Sect. area coeff. (C)	0.696	0.711	0.725	0.737	0.748	0.759	0.769	0.779
14	Waterpl. area coeff. (C)	0.669	0.693	0.736	0.760	0.775	0.784	0.791	0.795
15	LCB from zero pt. (+ve f	19.708	18.726	18.236	17.985	17.845	17.790	17.764	17.766
16	LCF from zero pt. (+ve f	19.003	17.911	17.624	17.532	17.535	17.620	17.715	17.833
17	KB m	0.639	1.272	1.891	2.501	3.105	3.702	4.295	4.883
18	KG m	6.616	6.616	6.616	6.616	6.616	6.616	6.616	6.616
19	BMT m	71.015	35.066	22.855	16.830	13.273	10.911	9.243	8.001
20	BML m	61.923	47.428	36.523	29.778	25.387	22.080	19.652	17.754
21	GMT m	65.038	29.721	18.130	12.715	9.761	7.997	6.921	6.267
22	GML m	55.946	42.084	31.798	25.663	21.876	19.166	17.330	16.020
23	KMt m	71.654	36.337	24.747	19.331	16.377	14.613	13.537	12.883
24	KML m	62.562	48.700	38.414	32.279	28.492	25.782	23.946	22.636
25	Immersion (TPC) tonne/c	1.256	2.054	2.629	3.077	3.444	3.743	3.999	4.219
26	MTc tonne.m	1.069	2.696	4.040	5.226	6.368	7.418	8.503	9.621
27	RM at 1deg = GMT.Disp.	81.161	124.323	150.405	169.047	185.508	202.093	221.710	245.742
28	Max deck inclination deg	0.0000	0.0000	0.0000	0.0000	0.0000	0.0000	0.0000	0.0000
29	Trim angle (+ve by stern)	0.0000	0.0000	0.0000	0.0000	0.0000	0.0000	0.0000	0.0000





# Hydrostatics (Results)

- The graphical representation of the results can be illustrated from:
  - Go to Window → Graph..

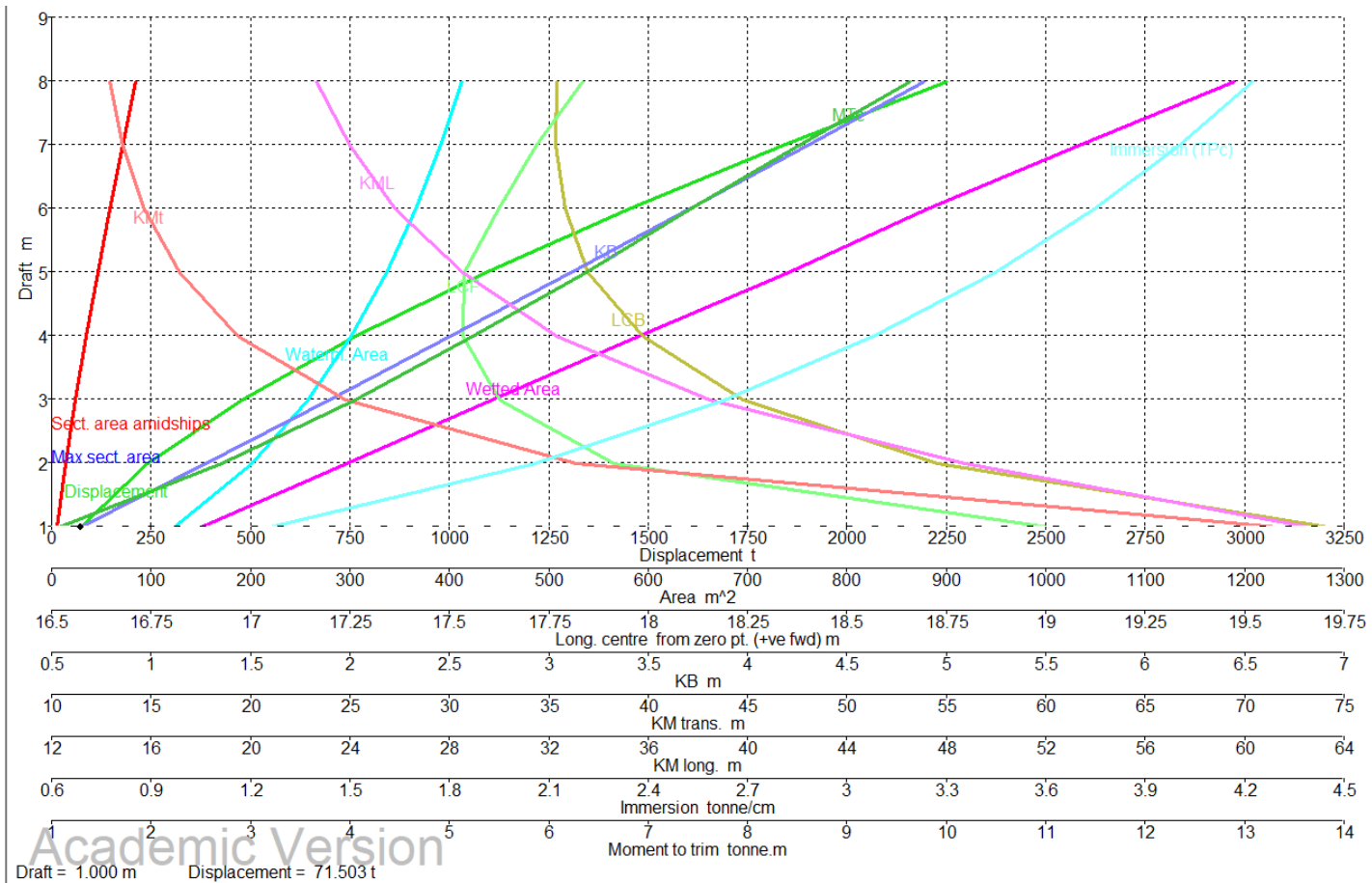

**Hydrostatics**

- Displacement
- Max sect. area
- Sect. area amidships
- Wetted Area
- Waterpl. Area
- LCB
- LCF
- KB
- KMT
- KML
- Immersion (TPC)
- MTc

Window    Help    Bentley Cloud

- Cascade
- Tile Horizontal
- Tile Vertical
- Arrange Icons
- Restore Default Layout
- View Direction ▶
- Loadcase ▶
- Damage ▶
- Input ▶
- Results ▶
- Graphs ▶
- 1 Perspective
- 2 empty LC 1
- 3 Damage
- 4 Input
- 5 Results
- 6 Graph**
- 7 Report



# Hydrostatics (Results)

- The show curves of form, change the type of curves from the tab above the Graph window

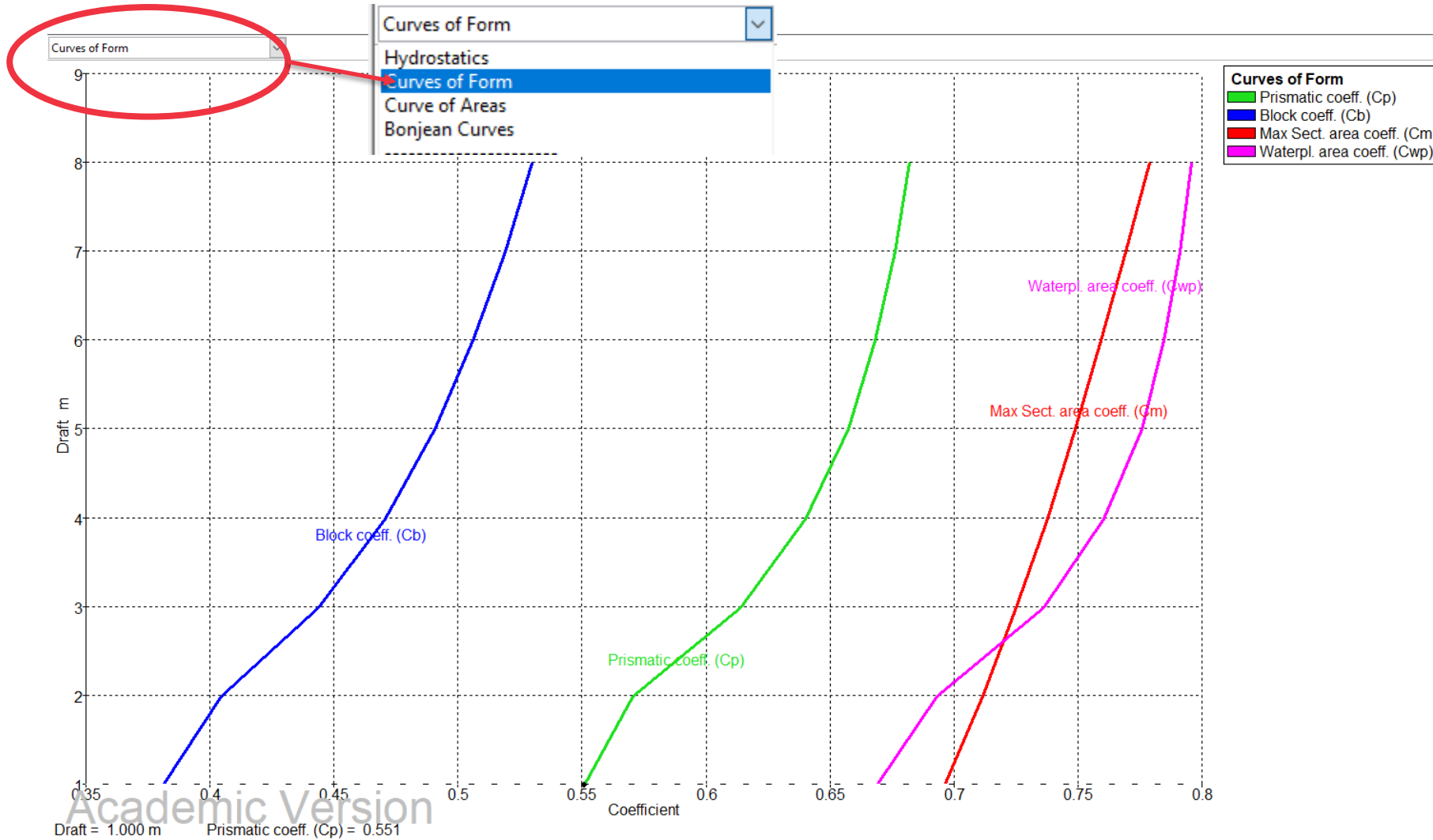



# Hydrostatics (Results)

- You can also show the curves of areas and Bonjean curves from the same tab.

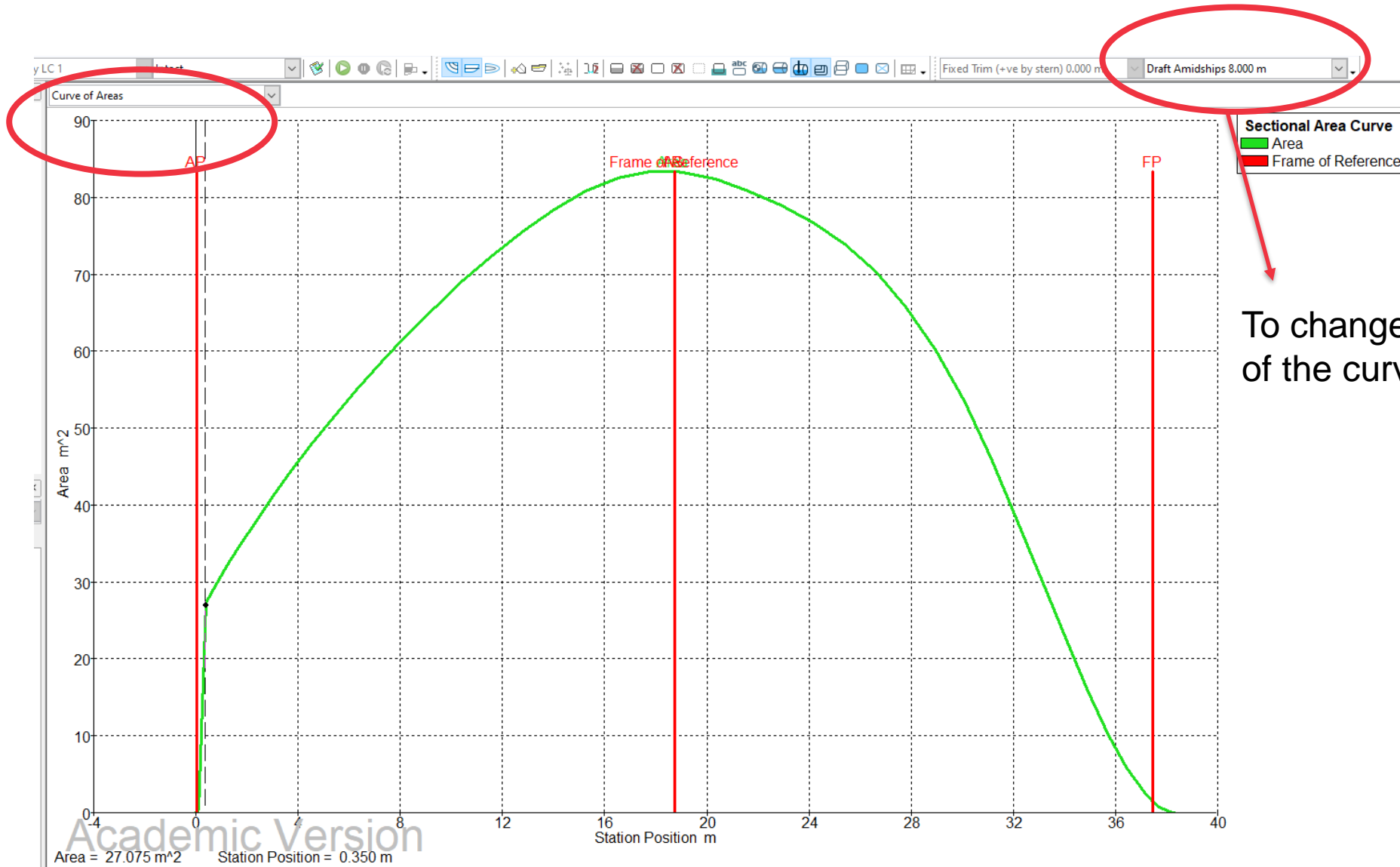

# Hydrostatics (Results)

- Bonjean curves

