

3 Definition and regulation

DEFINITION

A ship's hull form helps determine most of its main attributes; its stability characteristics; its resistance and therefore the power needed for a given speed; its seaworthiness; its manoeuvrability and its load carrying capacity. It is important, therefore, that the hull shape should be defined with some precision and unambiguously. To achieve this the basic descriptors used must be defined. Not all authorities use the same definitions and it is important that the reader of a document checks upon the exact definitions applying. Those used in this chapter cover those used by Lloyd's Register and the United Kingdom Ministry of Defence. Most are internationally accepted. Standard units and notation are discussed in Appendix A.

The geometry

A ship's hull is three dimensional and, except in a very few cases, is symmetrical about a fore and aft plane. Throughout this book a symmetrical hull form is assumed. The hull shape is defined by its intersection with three sets of mutually orthogonal planes. The horizontal planes are known as *waterplanes* and the lines of intersection are known as *waterlines*. The planes parallel to the middle line plane cut the hull in *buttock (or bow and buttock) lines*, the middle line plane itself defining the *profile*. The intersections of the athwartships planes define the *transverse sections*.

Three different lengths are used to define the ship (Figure 3.1). The *length between perpendiculars* (lbp), the *Rule length* of Lloyd's Register, is the distance measured along the summer load waterplane (the design waterplane in the case of warships) from the after to the fore perpendicular. The *after perpendicular* is taken as the after side of the rudder post, where fitted, or the line passing through the centreline of the rudder pintles. The *fore perpendicular* is the vertical line through the intersection of the forward side of the stem with the summer load waterline.

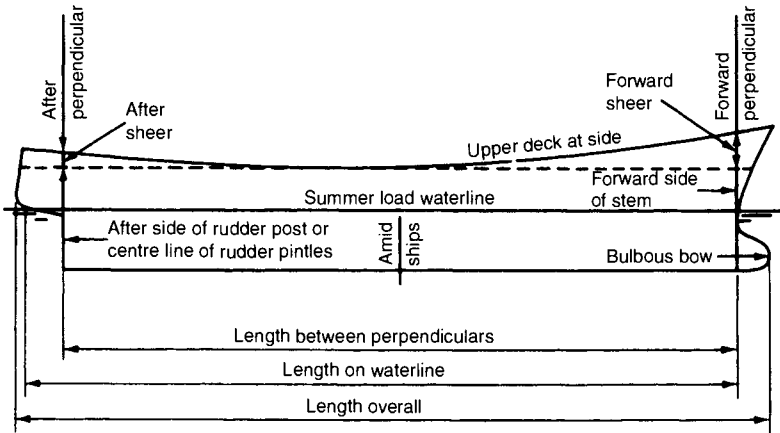

Figure 3.1 Principal dimensions

The *length overall* (loa) is the distance between the extreme points forward and aft measured parallel to the summer (or design) waterline. Forward the point may be on the raked stem or on a bulbous bow.

The *length on the waterline* (lwl) is the length on the waterline, at which the ship happens to be floating, between the intersections of the bow and after end with the waterline. If not otherwise stated the summer load (or design) waterline is to be understood.

The mid-point between the perpendiculars is called *amidships* or *midships*. The section of the ship at this point by a plane normal to both the summer waterplane and the centreline plane of the ship is called the *midship section*. It may not be the largest section of the ship. Unless otherwise defined the *beam* is usually quoted at amidships. The beam (Figure 3.2) most commonly quoted is the *moulded beam*, which is the greatest distance between the inside of plating on the two sides of the

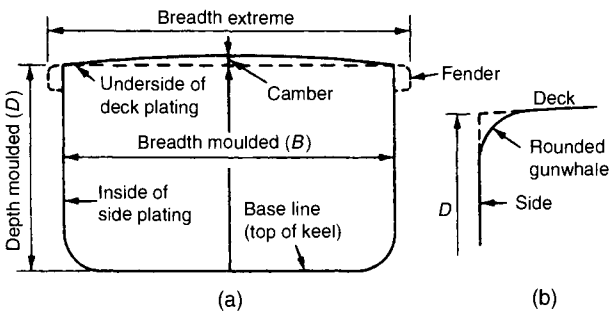

Figure 3.2 Breadth measurements

ship at the greatest width at the section chosen. The *breadth extreme* is measured to the outside of plating but will also take account of any overhangs or flare.

The ship *depth* (Figure 3.2) varies along the length but is usually quoted for amidships. As with breadth it is common to quote a *moulded depth*, which is from the underside of the deck plating at the ship's side to the top of the inner keel plate. Unless otherwise specified, the depth is to the uppermost continuous deck. Where a rounded gunwhale is fitted the convention used is indicated in Figure 3.2.

Sheer (Figure 3.1) is a measure of how much a deck rises towards the stem and stern. It is defined as the height of the deck at side above the deck at side amidships.

Camber or *round of beam* is defined as the rise of the deck in going from the side to the centre as shown in Figure 3.3. For ease of construction camber may be applied only to weather decks, and straight line camber often replaces the older parabolic curve.

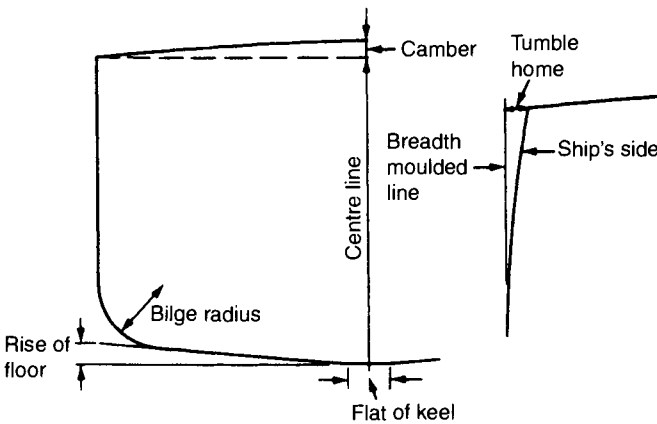

Figure 3.3 Section measurements

The bottom of a ship, in the midships region, is usually flat but not necessarily horizontal. If the line of bottom is extended out to intersect the moulded breadth line (Figure 3.3) the height of this intersection above the keel is called the *rise of floor* or *deadrise*. Many ships have a flat keel and the extent to which this extends athwartships is termed the *flat of keel* or *flat of bottom*.

In some ships the sides are not vertical at amidships. If the upper deck beam is less than that at the waterline it is said to have *tumble home*, the value being half the difference in beams. If the upper deck has a greater beam the ship is said to have *flare*. All ships have flare at a distance from amidships.

The *draught* of the ship at any point along its length is the distance from the keel to the waterline. If a *moulded draught* is quoted it is measured from the inside of the keel plating. For navigation purposes it is important to know the maximum draught. This will be taken to the bottom of any projection below keel such as a bulbous bow or sonar dome. If a waterline is not quoted the design waterline is usually intended. To aid the captain draught marks are placed near the bow and stern and remote reading devices for draught are often provided. The difference between the draughts forward and aft is referred to as the *trim*. Trim is said to be *by the bow* or *by the stern* depending upon whether the draught is greater forward or aft. Often draughts are quoted for the two perpendiculars. Being a flexible structure a ship will usually be slightly curved fore and aft. This curvature will vary with the loading. The ship is said to *hog* or *sag* when the curvature is concave down or up respectively. The amount of hog or sag is the difference between the actual draught amidships and the mean of the draughts at the fore and after perpendiculars.

Air draught is the vertical distance from the summer waterline to the highest point in the ship, usually the top of a mast. This dimension is important for ships that need to go under bridges in navigating rivers or entering port. In some cases the topmost section of the mast can be struck to enable the ship to pass.

Freeboard is the difference between the depth at side and the draught, that is it is the height of the deck above the waterline. The freeboard is usually greater at the bow and stern than at amidships. This helps create a drier ship in waves. Freeboard is important in determining stability at large angles.

Representing the hull form

The hull form is portrayed graphically by the *lines plan* or *sheer plan* (Figure 3.4). This shows the various curves of intersection between the hull and the three sets of orthogonal planes. Because the ship is symmetrical, by convention only one half is shown. The curves showing the intersections of the vertical fore and aft planes are grouped in the *sheer profile*; the waterlines are grouped in the *half breadth plan*; and the sections by transverse planes in the *body plan*. In merchant ships the transverse sections are numbered from aft to forward. In warships they are numbered from forward to aft although the forward half of the ship is still, by tradition, shown on the right hand side of the body plan. The distances of the various intersection points from the middle line plane are called *offsets*.

Clearly the three sets of curves making up the lines plan are interrelated as they represent the same three dimensional body. This interdependency

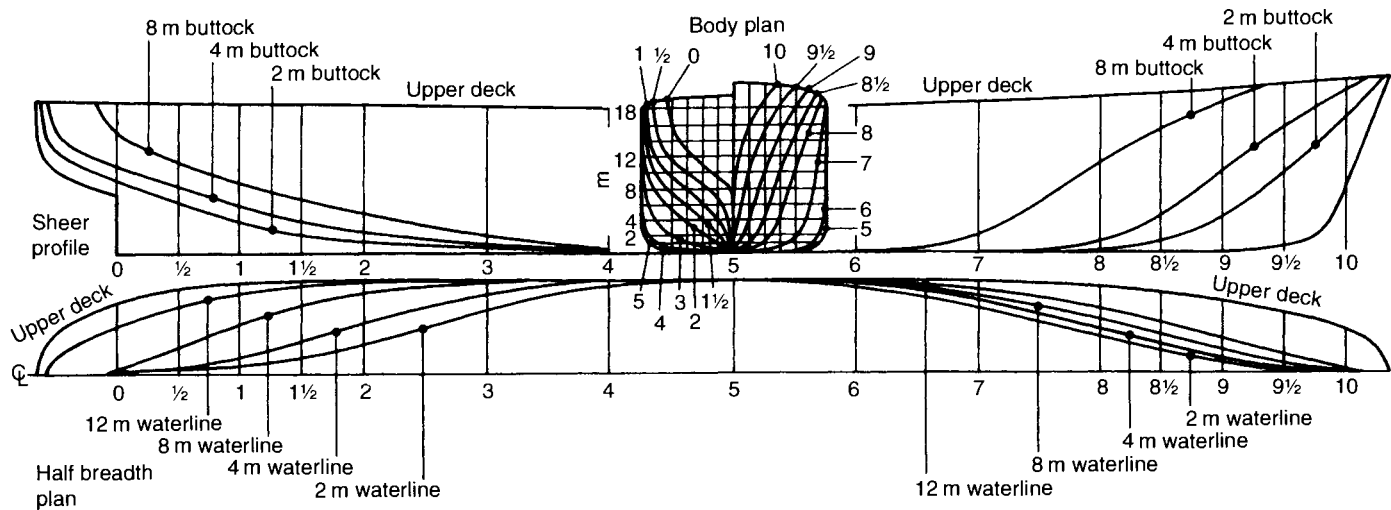

Figure 3.4 Lines plan

is used in manual fairing of the hull form, each set being faired in turn and the changes in the other two noted. At the end of the iteration the three sets will be mutually compatible. Fairing is usually now carried out by computer. Indeed the form itself is often generated directly from the early design processes in the computer. Manual fairing is done first in the design office on a reduced scale drawing. To aid production the lines used to be laid off, and refaired, full scale on the floor of a building known as the mould loft. Many shipyards now use a reduced scale, say one-tenth, for use in the building process. For computer designed ships the computer may produce the set of offsets for setting out in the shipyard or, more likely, it will provide computer tapes to be used in computer aided manufacturing processes.

In some ships, particularly carriers of bulk cargo, the transverse cross section is constant for some fore and aft distance near amidships. This portion is known as the *parallel middle body*.

Where there are excrescences from the main hull, such as shaft bossings or a sonar dome, these are treated as *appendages* and faired separately.

Hull characteristics

Having defined the hull form it is possible to derive a number of characteristics which have significance in determining the general performance of the ship. As a floating body, a ship in equilibrium will displace its own weight of water. This is explained in more detail later. Thus the volume of the hull below the design load waterline must represent a weight of water equal to the weight of the ship at its designed load. This *displacement*, as it is called, can be defined as:

$$\Delta = \rho g \nabla$$

where:

ρ = the density of the water in which the ship is floating

g = the acceleration due to gravity

∇ = the underwater volume.

It should be noted that displacement is a force and will be measured in newtons.

For flotation, stability, and hydrodynamic performance generally, it is this displacement, expressed either as a volume or a force, that is of interest. For rule purposes Lloyd's Register also use a *moulded displacement* which is the displacement within the moulded lines of the ship between perpendiculars.

It is useful to have a feel for the fineness of the hull form. This is provided by a number of *form coefficients* or *coefficients of fineness*. These are defined as follows, where ∇ is the volume of displacement:

$$\text{Block coefficient } C_B = \frac{\nabla}{L_{PP} BT}$$

where:

L_{PP} is length between perpendiculars

B is the extreme breadth underwater

T is the mean draught.

Corresponding to their moulded displacement Lloyd's Register use a block coefficient based on the moulded displacement and the Rule length. This will not be used in this book.

$$\text{Coefficient of fineness of waterplane, } C_{WP} = \frac{A_W}{L_{WL} B}$$

where:

A_W is waterplane area

L_{WL} is the waterline length

B is the extreme breadth of the waterline.

$$\text{Midship section coefficient, } C_M = \frac{A_M}{BT}$$

where:

A_M is the midship section area

B is the extreme underwater breadth amidships.

$$\text{Longitudinal prismatic coefficient, } C_p = \frac{\nabla}{A_M L_{PP}}$$

It will be noted that $C_M \times C_p = C_B$

$$\text{Vertical prismatic coefficient, } C_{VP} = \frac{\nabla}{A_W T}$$

It will be noted that these are ratios of the volume of displacement to various circumscribing rectangular or prismatic blocks, or of an area to the circumscribing rectangle. In the above, use has been made of displacement and not the moulded dimensions. This is because the coefficients are used in the early design stages and the displacement

dimensions are more likely to be known. Practice varies, however, and moulded dimensions may be needed in applying some classification societies' rules.

Some typical values are presented in the table below:

<i>Type of vessel</i>	<i>Block coefficient</i>	<i>Prismatic coefficient</i>	<i>Midship area coefficient</i>
Crude oil carrier	0.82–0.86	0.82–0.90	0.98–0.99
Product carrier	0.78–0.83	0.80–0.85	0.96–0.98
Dry bulk carrier	0.75–0.84	0.76–0.85	0.97–0.98
Cargo ship	0.60–0.75	0.61–0.76	0.97–0.98
Passenger ship	0.58–0.62	0.60–0.67	0.90–0.95
Container ship	0.60–0.64	0.60–0.68	0.97–0.98
Ferries	0.55–0.60	0.62–0.68	0.90–0.95
Frigate	0.45–0.48	0.60–0.64	0.75–0.78
Tug	0.54–0.58	0.62–0.64	0.90–0.92
Yacht	0.15–0.20	0.50–0.54	0.30–0.35
Icebreaker	0.60–0.70		

The values of these coefficients can provide useful information about the ship form but the above values are for rough guidance only. For instance, the low values of block coefficient for cargo liners would be used by the high speed refrigerated ships. The low value for ice-breakers reflects the hull form forward which is shaped to help the ship drive itself up on to the ice and break it. The great variation in size and speed of modern ship types means that the coefficients of fineness also vary greatly. It is safest to check the values of a similar ship in terms of use, size and speed.

The block coefficient indicates whether the form is full or fine and whether the waterlines will have large angles of inclination to the middle line plane at the ends. Large values signify large wavemaking resistance at speed. A slow ship can afford a relatively high block coefficient as its resistance is predominately frictional. A high value is good for cargo carrying and is often obtained by using a length of *parallel middle body*, perhaps 15–20 per cent of the total length.

The angle at the bow is termed as the *angle of entry* and influences resistance. As speed increases a designer will reduce the length of parallel middle body to give a lower prismatic coefficient, keeping the same midship area coefficient. As speed increases still further the midship area coefficient will be reduced, usually by introducing a rise of floor. A low value of midship section coefficient indicates a high rise of floor with rounded bilges. It will be associated with a higher prismatic coefficient. Finer ships will tend to have their main machinery spaces nearer amidships to get the benefit of the fuller sections. There is a

compromise between this and the desire to keep the shaft length as short as possible.

A large value of vertical prismatic will indicate body sections of U-form; a low value will indicate V-sections. These features will affect the seakeeping performance.

DISPLACEMENT AND TONNAGE

Displacement

A ship's *displacement* significantly influences its behaviour at sea. Displacement is a force and is expressed in newtons but the term *mass displacement* can also be used.

Deadweight

Although influencing its behaviour, displacement is not a direct measure of a ship's carrying capacity, that is, its earning power. To measure capacity *deadweight* and *tonnage* are used.

The *deadweight*, or *deadmass* in terms of mass, is the difference between the load displacement up to the minimum permitted freeboard and the *lightweight* or light displacement. The lightweight is the weight of the hull and machinery so the deadweight includes the cargo, fuel, water, crew and effects. The term *cargo deadweight* is used for the cargo alone. A table of deadweight against draught, for fresh and salt water, is provided to a ship's master in the form of a *deadweight scale*. This may be in the form of a diagram, a set of tables or, more likely these days, as software.

Tonnage

Ton is derived from *tun*, which was a wine cask. The number of tuns a ship could carry was a measure of its capacity. Thus tonnage is a volume measure, not a weight measure, and for many years the standard ton was taken as 100 cubic feet. Two 'tonnages' are of interest to the international community – one to represent the overall size of a vessel and one to represent its carrying capacity. The former can be regarded as a measure of the difficulty of handling and berthing and the latter of earning ability. Because of differences between systems adopted by different countries, in making allowances say for machinery spaces, etc., there were many anomalies. Sister ships could have different tonnages merely because they flew different flags. It was to remove these anomalies and establish an internationally approved system that the International Convention on Tonnage Measurement of Ships, was adopted in 1969. It came into force in 1982 and became fully operative

in 1994. The Convention was held under the auspices of the International Maritime Organisation (IMO) to produce a universally recognised system for tonnage measurement. It provided for the independent calculation of gross and net tonnages and has been discussed in some detail by Wilson (1970).

The two parameters of gross and net tonnage are used. *Gross tonnage* is based on the volume of all enclosed spaces. *Net tonnage* is the volume of the cargo space plus the volume of passenger spaces multiplied by a coefficient to bring it generally into line with previous calculations of tonnage. Each is determined by a formula.

$$\text{Gross tonnage (GT)} = K_1 V$$

$$\text{Net tonnage (NT)} = K_2 V_c \left(\frac{4T}{3D} \right)^2 + K_3 \left(N_1 + \frac{N_2}{10} \right)$$

where:

V = total volume of all enclosed spaces of the ship in cubic metres

$$K_1 = 0.2 + 0.02 \log_{10} V$$

V_c = total volume of cargo spaces in cubic metres

$$K_2 = 0.2 + 0.02 \log_{10} V_c$$

$$K_3 = 1.25 \frac{GT + 10\,000}{10\,000}$$

D = moulded depth amidships in metres

T = moulded draught amidships in metres

N_1 = number of passengers in cabins with not more than eight berths

N_2 = number of other passengers

$N_1 + N_2$ = total number of passengers the ship is permitted to carry.

In using these formulae:

- (1) When $N_1 + N_2$ is less than 13, N_1 and N_2 are to be taken as zero.
- (2) The factor $(4T/3D)^2$ is not to be taken as greater than unity and the term $K_2 V_c (4T/3D)^2$ is not to be taken as less than $0.25GT$.
- (3) NT is not to be less than $0.30GT$.
- (4) All volumes included in the calculation are measured to the inner side of the shell or structural boundary plating, whether or not insulation is fitted, in ships constructed of metal. Volumes of appendages are included but spaces open to the sea are excluded.
- (5) GT and NT are stated as dimensionless numbers. The word ton is no longer used.

Other tonnages

Special tonnages are calculated for ships operating through the Suez and Panama Canals. They are shown on separate certificates and charges for the use of the canals are based on them.

REGULATION

There is a lot of legislation concerning ships, much of it concerned with safety matters and the subject of international agreements. For a given ship the application of this legislation is the responsibility of the government of the country in which the ship is registered. In the United Kingdom it is the concern of the Maritime and Coastguard Agency (MCA), an executive agency of the Department for Transport (DfT) responsible to the Secretary of State for Transport. The MCA was established in 1998 by merging the Coastguard and Marine Safety Agencies. It is responsible for:

- (1) providing a 24 hour maritime search and rescue service;
- (2) the inspection and enforcement of standards of ships;
- (3) the registration of ships and seafarers;
- (4) pollution prevention and response.

It aims to promote high standards in the above areas and to reduce the loss of life and pollution. Some of the survey and certification work has been delegated to classification societies and other recognised bodies.

Some of the matters that are regulated in this way are touched upon in other chapters, including subdivision of ships, carriage of grain and dangerous cargoes. Tonnage measurement has been discussed above. The other major area of regulation is the freeboard demanded and this is covered by the *Load Line Regulations*.

Load lines

An important insurance against damage in a merchant ship is the allocation of a *statutory freeboard*. The rules governing this are somewhat complex but the intention is to provide a simple visual check that a laden ship has sufficient *reserve of buoyancy* for its intended service.

The load line is popularly associated with the name of Samuel Plimsoll who introduced a bill to Parliament to limit the draught to which a ship could be loaded. This reflects the need for some minimum watertight volume of ship above the waterline. That is a minimum

freeboard to provide a reserve of buoyancy when a ship moves through waves, to ensure an adequate range of stability and enough bouyancy following damage to keep the ship afloat long enough for people to get off.

Freeboard is measured downwards from the *freeboard deck* which is the uppermost complete deck exposed to the weather and sea, the deck and the hull below it having permanent means of watertight closure. A lower deck than this can be used as the freeboard deck provided it is permanent and continuous fore and aft and athwartships. A basic freeboard is given in the Load Line Regulations, the value depending upon ship length and whether it carries liquid cargoes only in bulk. This basic freeboard has to be modified for the block coefficient, length to depth ratio, the sheer of the freeboard deck and the extent of superstructure. The reader should consult the latest regulations for the details for allocating freeboard. They are to be found in the Merchant Shipping (Load Line) Rules.

When all corrections have been made to the basic freeboard the figure arrived at is termed the *Summer freeboard*. This distance is measured down from a line denoting the top of the freeboard deck at side and a second line is painted on the side with its top edge passing through the centre of a circle, Figure 3.5.

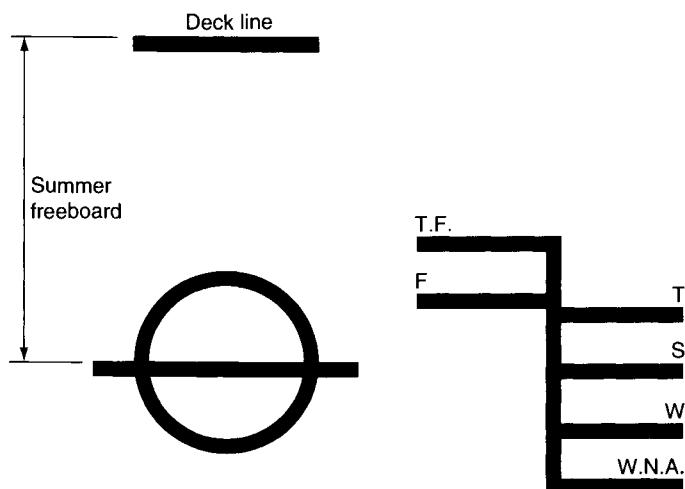

Figure 3.5 Load line markings

To allow for different water densities and the severity of conditions likely to be met in different seasons and areas of the world, a series of extra lines are painted on the ship's side. Relative to the Summer freeboard,

for a Summer draught of T , the other freeboards are as follows:

- (1) The Winter freeboard is $T/48$ greater.
- (2) The Winter North Atlantic freeboard is 50 mm greater still.
- (3) The Tropical freeboard is $T/48$ less.
- (4) The Fresh Water freeboard is $\Delta/40 t$ cm less, where Δ is the displacement in tonne and t is the tonnes per cm immersion.
- (5) The Tropical Fresh Water freeboard is $T/48$ less than the Fresh Water freeboard.

Passenger ships

As might be expected ships designated as passenger ships are subject to very stringent rules. A passenger ship is defined as one carrying more than twelve passengers. It is issued with a *Passenger Certificate* when it has been checked for compliance with the regulations. Various maritime nations had rules for passenger ships before 1912 but it was the loss of the *Titanic* in that year that focused international concern on the matter. An international conference was held in 1914 but it was not until 1932 that the International Convention for the Safety of Life at Sea was signed by the major nations. The Convention has been reviewed at later conferences in the light of experience. The Convention covers a wide range of topics including watertight subdivision, damaged stability, fire, life saving appliances, radio equipment, navigation, machinery and electrical installations.

The International Maritime Organisation (IMO) (www.imo.org)

The first international initiative in safety was hastened by the public outcry that followed the loss of the *Titanic*. It was recognised that the best way of improving safety at sea was by developing sound regulations to be followed by all shipping nations. However, it was not until 1948 that the United Nations Maritime Conference adopted the Convention on the Intergovernmental Maritime Consultative Organisation (IMCO). The Convention came into force in 1958 and in 1959 a permanent body was set up in London. In 1982 the name was changed to IMO. IMO now represents nearly 160 maritime nations. A great deal of information about the structure of IMO, its conventions and other initiatives will be found on its web site.

Apart from safety of life at sea, the organisation is concerned with facilitating international traffic, load lines, the carriage of dangerous cargoes and pollution. Safety matters concern not only the ship but also the crew, including the standards of training and certification. IMO has an Assembly which meets every 2 years and between assemblies

the organisation is administered by a Council. Its technical work is conducted by a number of committees. It has promoted the adoption of some 30 Conventions and Protocols and of some 700 Codes and Recommendations related to maritime safety and the prevention of pollution. Amongst the conventions are the *Safety of Life at Sea Convention* (SOLAS) and the *International Convention on Load Lines*, and the *Convention on Marine Pollution* (MARPOL). The benefits that can accrue from satellites particularly as regards the transmission and receipt of distress messages, were covered by the *International Convention on the International Maritime Satellite Organisation* (INMARSAT). The *Global Maritime Distress and Safety System* is now operative. It ensures assistance to any ship in distress anywhere in the world. All the conventions and protocols are reviewed regularly to reflect the latest experience at sea. Although much of the legislation is in reaction to problems encountered, the organisation is increasingly adopting a pro-active policy.

By its nature the bringing into force of some new, or a change to an existing, convention is a long process. When a problem is recognised and agreed by the Assembly or Council, the relevant committee must consider it in detail and draw up proposals for dealing with it. A draft proposal must then be considered and discussed by all interested parties. An amended version is, in due course, adopted and sent to governments. Before coming into force the convention must be ratified by those governments who accept it and who are then bound by its conditions. Usually a new convention comes into force about 5 years after it is adopted by IMO. Most maritime countries have ratified IMO's conventions, some of which apply to more than 98 per cent of the world's merchant tonnage.

Although the governments that ratify conventions are responsible for their implementation in ships which fly their flag, it becomes the responsibility of owners to ensure that their ships meet IMO standards. The *International Safety Management (ISM) Code* which came into force in 1998 is meant to ensure they do, by requiring them to produce documents specifying that their ships do meet the requirements. Port State Control (PSC) gives a country a right to inspect ships not registered in that country. The ships can be detained if their condition and equipment are not in accord with international regulations or if they are not manned and operated in compliance with those rules. That is, if they are found to be sub-standard or unsafe. Since a ship may well visit several ports in an area it is advantageous if port authorities in that area co-operate. IMO has encouraged the establishment of regional PSC organisations. One region is Europe and the north Atlantic; another Asia and the Pacific.

Much of the regulation agreed with IMO requires certificates to show that the requirements of the various instruments have been met.

In many cases this involves a survey which may mean the ship being out of service for several days. To reduce the problems caused by different survey dates and periods between surveys, IMO introduced in 2000 a *harmonised system of ship survey and certification*. This covers survey and certification requirements of the conventions on safety of life at sea, load lines, pollution and a number of codes covering the carriage of dangerous substances. Briefly the harmonised system provides a 1-year standard survey interval, some flexibility in timing of surveys, dispensations to suit the operational program of the ship and maximum validity periods of 5 years for cargo ships and 1 year for passenger ships. The main changes to the SOLAS and Load Line Conventions are that annual inspections are made mandatory for cargo ships with unscheduled inspections discontinued.

SOLAS and the Collision Regulations (COLREGS) require ships to comply with rules on design, construction and equipment. SOLAS coverage includes life saving equipment, both the survival craft (lifeboats and liferafts) and personal (life jackets and immersion suits). Numbers of such equipments are stated on the Safety Certificate.

Classification societies

There are many classification societies which co-operate through the *International Association of Classification Societies* (IACS) (www.iacs.org.uk), including:

American Bureau of Shipping	www.eagle.org
Bureau Veritas	www.veristar.com
China Classification Society	www.ccs.org.cn
Det Norske Veritas	www.dnv.com
Germanischer Lloyd	www.GermanLloyd.org
Korean Register of Shipping	www.krs.co.kr
Lloyds Register of Shipping	www.lr.org
Nippon Kaiji Kyokai	www.classnk.or.jp
Registro Italiano Navale	www.rina.it
Russian Maritime Register of Shipping	www.rs-head.spb.ru/

As with IMO, a lot of information on the classification societies can be gleaned from their web sites. The work of the classification societies is exemplified by *Lloyd's Register* (LR) of London which was founded in 1760 and is the oldest society. It classes some 6700 ships totalling about 96 million in gross tonnage. When a ship is built to LR class it must meet the requirements laid down by the society for design and build. LR demands that the materials, structure, machinery and equipment are of the required quality. Construction is surveyed to ensure proper

standards of workmanship are adhered to. Later in life, if the ship is to retain its class, it must be surveyed at regular intervals. The scope and depth of these surveys reflect the age and service of the ship. Thus, through classification, standards of safety, quality and reliability are set and maintained. LR have developed a *Hull Condition Monitoring Scheme* to assist in the inspection and maintenance of tankers and bulk carriers. A database is created using a vessel representation program to generate the structural codes, geometry and rule and renewal thickness of individual plates and stiffeners. Results of class surveys and owners' inspections are input to the database which can be accessed on board ship or ashore. Tabular and graphical outputs are available.

Classification applies to ships and floating structures extending to machinery and equipment such as propulsion systems, liquefied gas containment systems and so on.

For many years Lloyd's Rules were in tabular form basing the scantlings required for different types of ship on their dimensions and tonnage. These gave way to rational design standards and now computer based assessment tools allow a designer to optimise the design with minimum scantlings and making it easier to produce. For a ship to be designed directly using analysis requires an extensive specification on how the analyses are to be carried out and the acceptance criteria to apply. Sophisticated analysis tools are needed to establish the loads to which the ship will be subject.

Classification societies are becoming increasingly involved in the classification of naval vessels. Typically they cover the ship and ship systems, including stability, watertight integrity, structural strength, propulsion, fire safety and life saving. They do not cover the weapon systems themselves but do cover the supporting systems. A warship has to be 'fit for service' as does any ship. The technical requirements to make them fit for service will differ, as would the requirements for a tanker and for a passenger ship. In the case of the warship the need to take punishment as a result of enemy action, including shock and blast, will lead to a more rugged design. There will be more damage scenarios to be considered with redundancy built into systems so that they are more likely to remain functional after damage.

The involvement of classification societies with naval craft has a number of advantages. It means warships will meet at least the internationally agreed safety standards to which merchant ships are subject. The navy concerned benefits from the world wide organisation of surveyors to ensure equipment, materials or even complete ships are of the right quality.

Lloyd's is international in character and is independent of government but has delegated powers, as do other classification societies, to carry out many of the statutory functions mentioned earlier. They carry out surveys and certification on behalf of more than 130 national

administrations. They also carry out statutory surveys covering the international conventions on load lines, cargo ship construction, safety equipment, pollution prevention, grain loading and so on, and issue International Load Line Certificates, Passenger Ship Safety Certificates and so on. The actual registering of ships is carried out by the government organisation. Naturally owners find it easier to arrange registration of their ships with a government, and to get insurance cover, if the ship has been built and maintained in accordance with the rules of a classification society.

Lloyd's Register must not be confused with Lloyd's of London, the international insurance market, which is a quite separate organisation although it had similar origins.

Impact of rules and regulations on design

A ship designer must satisfy not only the owner's stated requirements but also the IMO regulations and classification society rules. The first will define the type of ship and its characteristics such as size, speed and so on. The second broadly ensures that the ship will be safe and acceptable in ports throughout the world. They control such features as sub-division, stability, fire protection, pollution prevention and manning standards. The third sets out the 'engineering' rules by which the ship can be designed to meet the demands placed on it. They will reflect the properties of the materials used in construction and the loadings the ship is likely to experience in the intended service.

There are three basic forms the rules of a classification society may take:

- Prescriptive standards describing exactly what is required, reflecting that society's long experience and the gradual trends in technological development. They enable a design to be produced quickly and do not require the designer to have advanced structural design knowledge. They are not well suited to novel design configurations or to incorporating new, rapidly changing, technological developments. Because of this the performance standard approach is increasingly favoured.
- Performance standards which are flexible in that they set out aims to be achieved but leave the designer free to decide how to meet them within the overall constraints of the rules. They set standards and criteria to which the design must conform to provide the degree of safety and reliability demanded.
- The safety case approach which considers the totality of risks the ship is subject to scenarios of predictable incidents. A *formal safety assessment* (FSA) involves identifying hazards; assessing the risks associated with each hazard; considering alternative strategies and

making decisions so as to reduce the risks and their consequences to acceptable levels. Put another way the designer thinks what might go wrong, the consequences if it does go wrong, the implications for the design of reducing, or avoiding, the risk; making a conscious decision on how to manage the situation. Thus a designer might decide that although an event is of very low probability its repercussions are so serious that something must be done to reduce the hazard.

Although attractive in principle, FSA is an expensive approach and is likely to be used for individual projects only if they are high profile ones. It can be used, however, as the basis for developing future classification and convention requirements. One problem, particularly for radically new concepts is foreseeing what might happen and under what circumstances.

It is clear that probability theory is going to play an increasing part in design safety assessments and development. To quote two examples:

- When considering longitudinal strength the designer must assess the probability of the ship meeting various sea conditions; the need to operate or merely survive, in these conditions; the probability of the structure having various levels of built in stress and the probable state of the structure in terms of loss of plate thickness due to corrosion.
- In considering collision at sea, consideration must be given to the density of traffic in the areas in which the ship is to operate. Then there are the probabilities that the ship will be struck at a certain point along its length by a ship of a certain size and speed; that the collision will cause damage over a certain length of hull; the state of watertight doors and other openings. Then some allowance must be made for the actions of the crew in containing the incident.

Statistics are being gathered to help quantify these probabilities but many still require considerable judgement on the part of the designer.

Accident investigations

The Marine Accident Investigation Branch (MAIB) (www.maib.dft.gov.uk)

The MAIB is a branch of DETR which investigates all types of marine accident. It is independent of MCA and its head, the Chief Inspector of Marine Accidents, reports directly to the Secretary of State. The role of the MAIB is to determine the circumstances and causes of an accident with the aim of improving safety at sea and preventing future accidents. Their powers are set out in the Merchant Shipping Act.

The Salvage Association (www.wreckage.org)

Another type of investigation is carried out by the Salvage Association. This association serves the insurance industry. When instructed, it carries out surveys of casualties to ascertain the circumstances, investigate the cause, the extent of damage and to assess the cost to rectify. On-site inspections are usually needed although thought is being given to using remote video imaging fed back to experts at base. The Association aims to give a fast service, giving preliminary advice within 48 hours.

SUMMARY

It has been seen how a ship's principal geometric features can be defined and characterised. It will be shown in the next chapter how the parameters can be calculated and they will be called into use in later chapters. The concept and calculation of gross and net tonnage have been covered. The regulations concerning minimum freeboard values and the roles of the classification societies and government bodies have been outlined.

Whilst all legal requirements must be met, engineers have a much broader responsibility to the public and the profession and must do their best, using all available knowledge. This underlines the importance of engineers keeping abreast of developments in their field, through continuing professional development.