

AN EFFICIENT PROCEEDING OF TAKING DOWN THE LINES DRAWING FROM THE SHIP HERSELF

THE AUTHOR

graduated from the Faculty of Mechanical Engineering, University of Belgrade in 1951. He was commissioned to research work at the Ship Section, Mechanical Engineering Institute of the Serbian Academy of Sciences, first as research assistant and from April 1956 on as research officer. He was responsible for Marine Engineering in general and Torsional Vibrations in particular. He took part in designing a number of new vessels, took out some patents and wrote some papers. He holds membership in the Society of Engineers and Technicians of Yugoslavia and in the Yugoslav Society for Applied Mechanics.

IT HAPPENS very often in shipyard practice that the lines drawing has to be taken from the ship herself. This task is especially met when altering or repairing a ship whose plans are not available. As a matter of fact, such cases were particularly often in the period immediately after the war, but they occur permanently in some shipyards, too.

Beside the alterations and reparations to ships, the same task can be set for mere documentary purposes; the checking of the stability and propulsion characteristics for a ship whose plans are not available; making specific measurements of a ship's hull and so on.

However, although this task springs not too rarely in shipyard practice it is rather astonishing how primitively it has been performed so far. The usual practice is that of marking off two guiding-marks in the hold and of measuring the distances from them to some points on the frame. These measurements are taken to a drafting board later, and with a compass set to scale of the dimensions, arcs are struck on the paper giving points through which to run the curves of the sections. This method is applied mainly for the measurements from the inside of a

ship's hull, but sometimes similar outside measurements are made, too.

Another method of taking down the data for the lines drawing is that of fixing in the center line of the ship a vertical pillar with the horizontal guides through which measuring rods are pushed and so the half breadths of the frames are measured on different drafts.

The shortcomings of the displayed methods are evident: first of all not a ship's line as a whole is taken down, but only some points of it. Then the measuring itself of the distances of these points from the guiding-marks, since being performed in rather difficult ship conditions, is liable to many human and other variable errors. The guiding-marks are a problem by themselves. The transfer of these marks from one close compartment into the other is especially troublesome in the peaks and adjoining compartments where both the deck and the keel are considerably curved. Generally speaking the methods can be designated as indirect procedures, the lines coefficient tables being the intermediate links between the ship and the lines drawing as the end of the procedure.

Nevertheless, the displayed methods have been persistently applied for many decades. The matter as a whole has been considered as troublesome but not significant enough to deserve special consideration.

So far as the author is aware, only one attempt has hitherto been made to lay down a more modern basis for the procedure of taking down the lines of a ship's hull. This was made in USSR and that only in the most recent time. A photogrammetric method was developed there whereby the frames to be taken down are first colored and then the whole ship is photographed so that by photogrammetric methods the lines of the ship's hull can be reached afterwards much in the same manner as the geographical maps are made. It seems that this method has proved to be rather reliable and that it is striking root further in USSR. A book describing the procedure in full length appeared recently there (Kovtun, A.D.: "Primenenie fotografii dla sjemki s naturi obvodov korpusov sudov i grebnih vintov," Sudpromgiz, Leningrad, 1956).

As a matter of fact, the photogrammetric method is again an indirect proceeding, the snapshots and a series of unavoidable auxiliary means being the intermediate links between the ship and the end drawing.

Another new line of approach to the task of improving the proceedings of taking down the lines of a ship's hull will be the subject of this paper. The matter is about a direct proceeding which was launched recently in Yugoslavia by the present author.

The line of approach is a very simple one: sections of the ship may be taken down by means of a pantograph. Hence the method is necessarily a direct one: there are no intermediate steps between the ship and the lines drawing, the lines being drawn "on the spot."

Nevertheless, although both the basic idea and the pantographic drawing itself appear to be very simple and to require nothing more than a mere routine, many difficulties press against the realization of the mentioned idea in this field. Some of them are a matter of principle, while the others are of technical nature.

The major obstacle from the first group is the fact that the ship's hull is a voluminous, hence a 3-dimensional body, while all the normal lines of a ship are 2-coordinate, hence plane curves. Thus the application of a 3-coordinate pantograph ("relief"-pantograph) is of no use here. To obtain a direct method 2-coordinate pantograph has to be used. However, although the use of such a pantograph offers no difficulty (at least in the principle) if only a separate ship's section has to be taken down, the thing stands otherwise if the matter is about a body. Namely if a voluminous body has to be determined by a system of plane curves (all of which are paral-

lel to a reference plane), then not only the curves as such have to be taken down very precisely, but also the relative positioning of them must be determined completely. In order to achieve that a constant position towards an arbitrary reference line must be retained by the pantograph when taking down the lines by which the form of the body is to be determined.

For example when taking down the cross sections of a ship's hull the best reference line is the center line of the keel. When the pantograph is periodically shifted along the ship with a view to take down all the necessary cross sections, then not only the distance l_0 (Figure 1) and the angle ζ_0 (which determine the position of the pantograph towards the hull) are to be kept constant, but also the angle α_0 which represents the inclination of the pantograph itself against the line l_0 must be kept constant. It is hardly necessary to say that the plane of the cross section to be taken down and the working plane of the pantograph must coincide thereby.

If all the mentioned conditions are fulfilled, then not only the individual cross sections will be rightly taken down, but also their relative positioning on the pantograph drawing board will correspond just to the actual one on the ship herself. The sum of these conditions (constancy of l_0 , ζ_0 , α_0 , coincidence of planes) will be spoken of as the positioning of the pantograph. Hence this is an additional requirement which is entailed just by the fact that a voluminous, hence a 3-dimensional body, has to be determined by a 2-coordinate pantograph. Instead of the third coordinate, there is the requirement of the positioning of the pantograph.

The difficulties of the technical nature are as follows:

If a large pantograph of the same design as the small table pantographs (Figure 2) is constructed for our application it will be very clumsy and heavy. The weight of the linkage itself will be so considerable that the operator will not be able to support

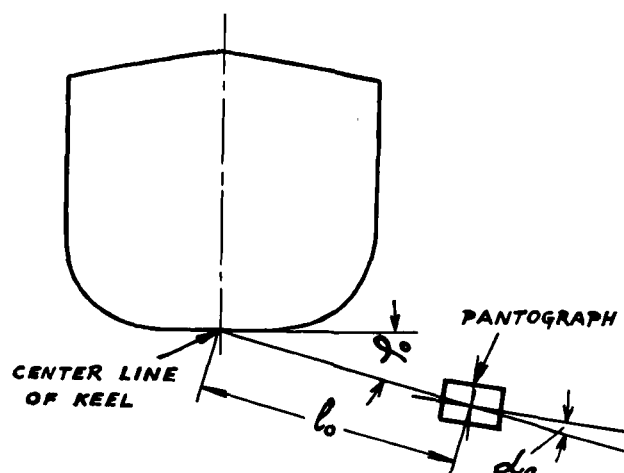

Figure 1.

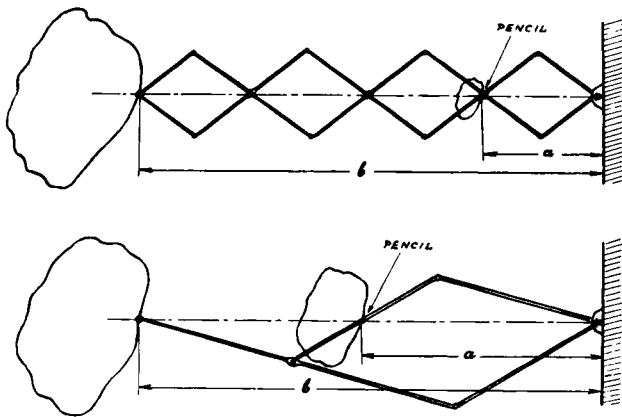

Figure 2.

its outer end which has to be moved over the ship's plating. Besides this weight will cause a considerable inflection of the linkage which will necessarily induce some deformations to the graph which is being drawn by the pantograph. Many shiftings of the pantograph along the ship (for the purpose of taking down all the necessary cross sections) will cause the linkage to become loose soonly, the pantograph becoming thus unservicable.

Besides the linkage pantographs cannot afford a sufficiently low reduction ratio. Reduction ratios down to 1:10 or so which are usual with the table

pantographs are quite insufficient for our application where the ratios of 1:20, 1:50, 1:100 or even lower ones are necessary.

Hence it is evident that quite a new pantograph has to be designed for the realization of the pantographic proceeding of the taking down of the lines of a ship's hull. Its main feature has to be that what comes in lieu of the linkage must be very light. Whereas the linkage with the table pantographs could be leaned against the table in many points, the element which in our case comes instead of it is hung freely in space between the ship and the pantograph drawing board. That is one reason more for it to be very light. Besides this fact induces us to speak of the new pantograph as the "space"-pantograph in contradistinction to the "table"-ones. (It will be remarked that in spite of its name the "space"-pantograph is no "relief"-pantograph, i.e., a 3-coordinate pantograph; it remains to be a simple 2-coordinate pantograph.)

The new pantograph is shown in Figure 3. Cable 7 is pulled through a radial hole in the horizontal axle 3 and after having been wound on the wheel 9 it is fixed to it. The axle 3 bears a light rule 4 which is easily revolvable (ball bearing) about it. The weight of the rule is balanced by the counter-weight 5, so that only negligible ball bearing friction has to be overcome to get the rule revolving about the axle.

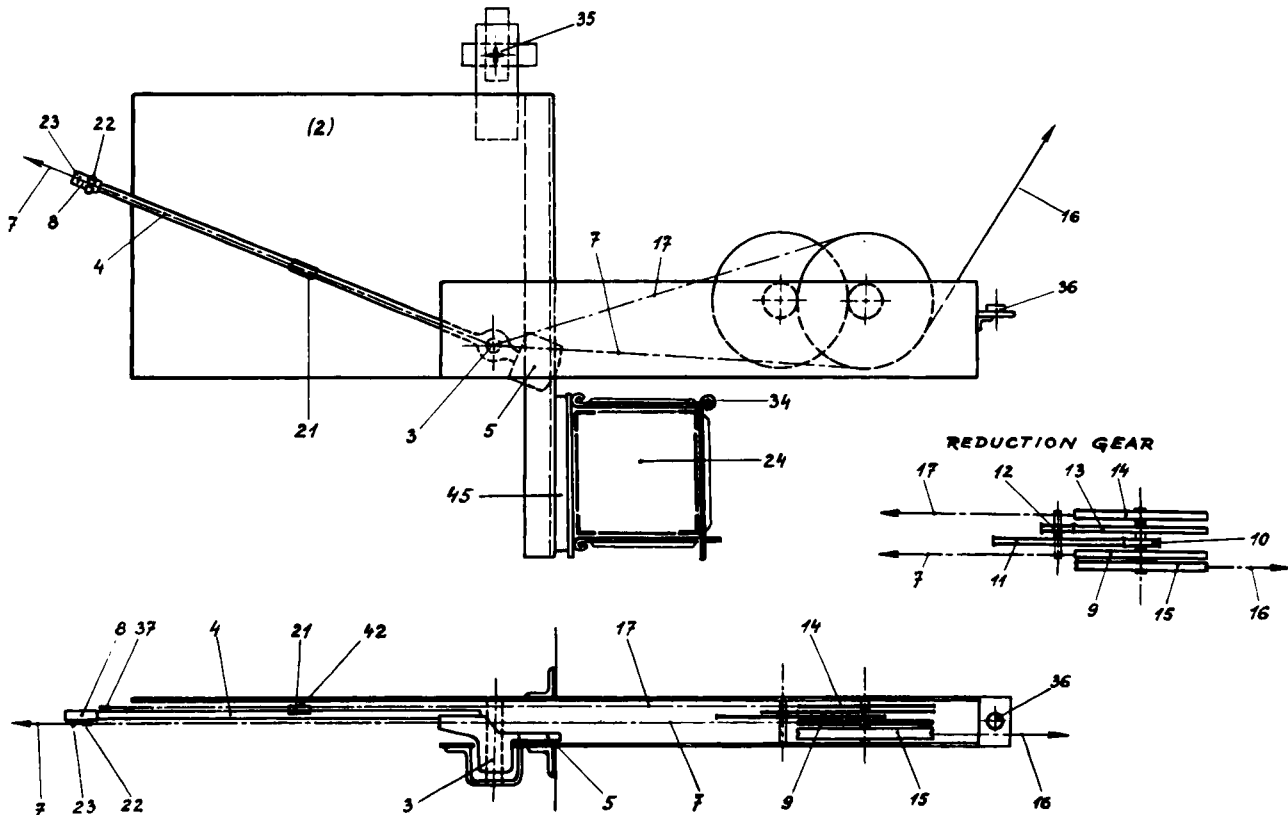

Figure 3.

On the top of the rule 4 there is a head 8 which bears two calibrated slots, one of which is horizontal, while the other is vertical. The free end of the cable 7 is pulled through these slots. The cable 7 is kept tight on behalf of the operator which pulls its free end outwards while the wheel 9 is pulled by a special cable 16 in the opposite direction (cable 16 is wound on the grooved wheel 15 and is fixed to it; the wheels 9 and 15 are steadily connected; free end of the cable 16 is passed through a pulley gear 18 which is suspended on a stand 19 and then is charged by the counterweight 20 (see Figure 4).

Thus on behalf of the tightness of the measuring cable 7 and the mentioned slots which are precisely calibrated to it, every movement of this cable in its vertical plane is rightly transmitted to the rule 4. The angle through which the rule 4 is revolved about the axle 3 is the same as the angle swept by the cable 7. Hence the first coordinate, i.e., the angle, is yet realized with our pantograph. It is evident that this pantograph is based on the polar coordinate system whose origin is the axis of the axle 3. Thus it remains only to provide means for the second coordinate of the system, i.e., the radius. Its measure is the extension of the measuring cable 7, i.e., the distance from its free end to the axis of the axle 3. But to get the reduction this extension must be reduced somehow and then delivered to the slider 21 (see Figure 3) which slides the surface of the rule 4 looking into the drawing board 2 of the pantograph. Thus the slider 21 is moved along the rule 4 in a determined proportion to the extension of the cable 7. It bears a pencil which draws the graph on the drawing board 2 of the pantograph, and so the second coordinate, i.e., the radius, is realized, too.

The moving of the slider 21 in a reduced scale is achieved by means of the reduction gear (toothed wheels 10, 11, 12, 13) which is included between the wheels 9 and 14 (see Figures 3 and 5). Then the slider is simply included in the circuit of the endless cable 17 which is pulled through the axle 3 and is suspended on the wheel 37 (which is fixed on the outer end of the rule) on one side and on the wheel 14 on the other one. One point of this cable which never abandons the wheel 14 is fixed to it.

Thus we have a pantograph which does not possess any of the aforesaid drawbacks of the table pantographs. Instead of the clumsy linkage here we have a cable which is extremely light and is almost mandatory for doings in space. Besides there is no limit with regard to the reduction ratio, the reduction gear offering the possibility for the adjustment of this ratio in a very wide range.

With such a pantograph we can rightly tackle the job of taking down the lines from the ship herself.

In Figure 4 there is represented the case of a river craft which is situated on the slipway perpendicular to the rails. The pantograph is situated on the downward slope at the foot of the ship and is fixed to a

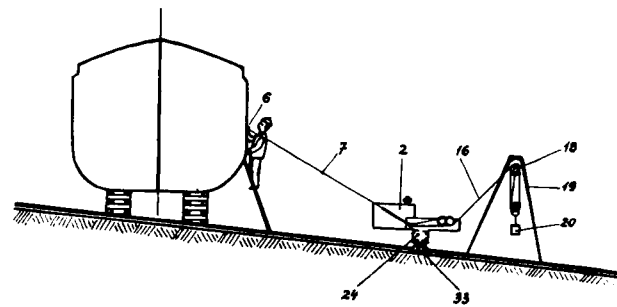

Figure 4.

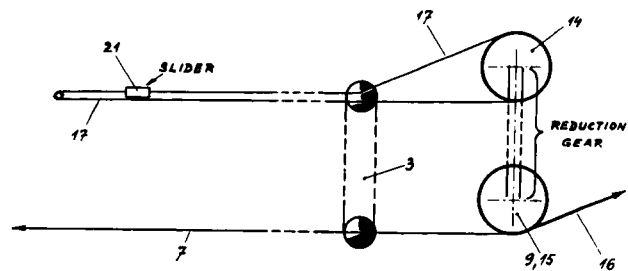

Figure 5.

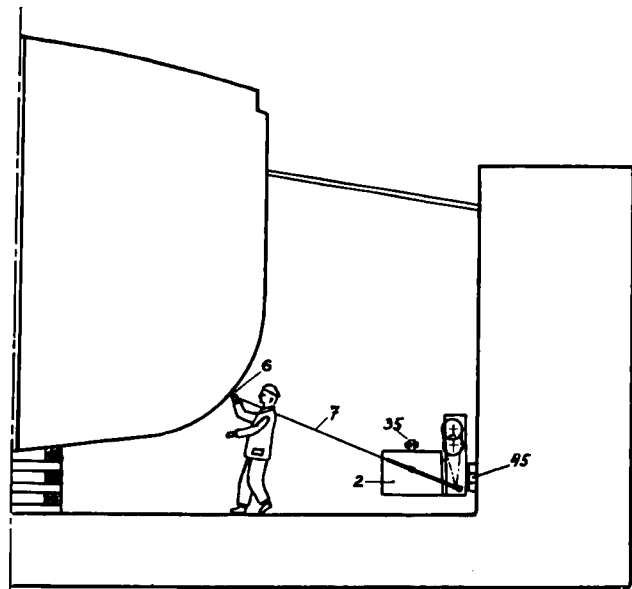

Figure 6.

horizontal beam 24 which is provisionally fastened to the rails of the slipway. Behind the beam there is the stand 19 with the pulley gear and the counterweight 20 for the tension of the measuring cable 7. Hence the operator has only to move the free end of the measuring cable 7 over the ship's plating and the cross section which is situated in the working plane of the pantograph will be drawn automatical-

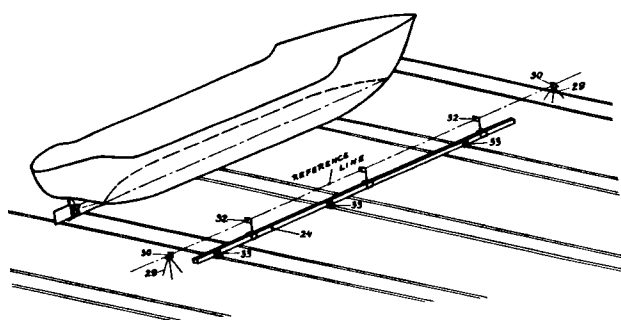

Figure 7.

ly on the drawing board ("working" plane is the vertical plane in which the cable 7 is being moved). After shifting the pantograph several times along the beam 24, the whole body plan of the ship will be drawn on the board.

The case of the river craft was shown first only for the purpose of clarity. Namely the disposition of the ship, pantograph and the counter-weight stand is normal here. Besides it may be here remarked that the pantograph must be placed relatively low so that the cable 7 can approach freely both the bottom and the side wall of the ship.

The disposition of the mentioned elements is mainly the same in the case of the ship in the dock (Figure 6). The counter-weight stand (it is not drawn in Figure 6) is placed on the bottom of the dock near the pantograph. The after part of the pantograph (portion pertaining to the reduction gear) is revolved by 90 degrees in order to bring the pantograph nearer to the inner side-wall of the dock. The pantograph is fixed to this wall by means of the screws which are fixed into it once and for all. The horizontal row of these screws is laid rather low so that the axle 3 of the pantograph is pretty well below the keel of any ship to enter the dock.

Whether the pantograph is fixed to the beam 24 laid down on the rails of the slipway, or to the screws on the inner side-wall of the dock, or even to an independent stand which is then shifted along the ship, this connection is effectuated always by means of a clutch 45 which enables both small translations

and rotations of the pantograph against the support. This is needful for the purpose of the precise positioning of the pantograph towards the ship.

The positioning itself is effectuated in this way:

Prior to the application of the pantograph a reference line is marked by one light beam (practice similar to that of aligning the shafting of the ship) which is set strictly parallel to the center line of the keel (light source, sight-holes and other things are put on two separate stands 29 and the beam 24—see Figure 7; similar provisions are made in the dock, too; in precise positioning of the reference line a theodolite can be used).

When later on the pantograph is being placed against successive frames it is always looked after the sight-hole 35 of the pantograph (see Figure 3) which must lie in the reference line. Water-level 36 must always indicate the same position of the pantograph, too.

Hence the mentioned clutch 45 of the pantograph is provided just for the purpose of enabling the adjustment of the pantograph against the reference line.

Thus what we specify as "the positioning of the pantograph" is both the marking of the reference line and the adjustment of the pantograph against it.

As to the reference line itself, it is chosen quite arbitrarily. It must be parallel to a known, straight and preferably characteristic line of the ship herself (which moreover may be hypothetical) and that is all. According as this line is perpendicular to the transverse, longitudinal or horizontal planes of the ship, the drawing on the pantograph's table will be respectively body plan, profile plan or half breadth plan. For the determination of the ship's lines it is quite sufficient to take down only the body plan wherefrom the other plans can easily be drawn out in the drawing office. Thus in the practice one reference line, preferably that which is parallel to the straight portion of the keel center line, is quite sufficient.

Turning now to some more significant details of the pantograph itself.

There is no use of the precise positioning of the

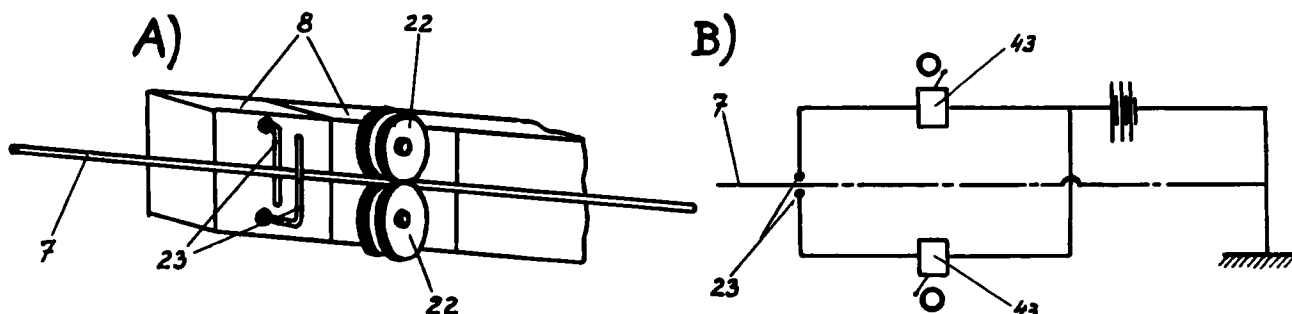

Figure 8.

pantograph if the measuring cable 7 is allowed to get out of the "working plane" of the pantograph. In order to frustrate this departure, the mentioned two slots on the head 8 of the rule 4 of the pantograph are constructed in a specific way.

In Figure 8 A there are two wheels 22 by the grooves of which a horizontal slot is formed. The height of this slot is equal to the diameter of the cable 7 while the breadth is somewhat larger. Hence any vertical movement of the cable 7 is rightly transmitted to the wheels 22, i.e. to the rule 4, while practically there is no hindrance by the horizontal slot for the cable 7 to move horizontally.

Just the reverse is the case with the vertical slot. It is formed by two pins 23 which moreover are included in two electrical circuits (Figure 8 B). Two bells 43 which are included in these circuits (the whole circuitry is fixed to the frame of the pantograph) are of quite different sounds. As distinct from the horizontal slot the cable 7 is not completely cramped for horizontal movement by the vertical slot as it was for the vertical movement with the horizontal slot. The interspace between the pins 23 is next to nothing larger than the diameter of the cable 7. Hence if the cable 7 is just in the middle of the interspace there is no contact between that cable and either of the pins 23; bells 43 are silent and the cable 7 lies in the working plane of the pantograph. However, the least departure from this plane is rightly warned by the ringing of one of the bells 43, and—due to different sound of rings—the operator rightly knows to which direction to move the cable 7 in order to bring it again in the right position.

The drawback of all the outside measurement methods is that the measurements are made only to the outer surface of ship's plating whereas the inner surface should actually be reached if a lines drawing is the aim of the job. Even the modern photogrammetric method is handicapped by this shortcoming, too. The allowance for the thickness of the plating can be effectuated by this method only additionally in the drawing office.

However, the pantographic proceeding is quite free from this imperfection. A steel ball 6 (Figure 9) is attached to the free end of the cable 7. The ball is held by the operator and is slowly moved over the ship's plating. Thus if the pantograph is adjusted normally the graph on its drawing board will represent the ship's section with the plating. But if the cable 7 is drawn in the ball 6 (by means of a simple screw device) by the amount of the plating thickness δ , the graph on the drawing board will represent just the bare ship's section so that no additional allowance for plating thickness δ will be necessary.

The work of the positioning of the pantograph can be reduced almost completely if we renounce the lines drawing as a direct result of the proceeding.

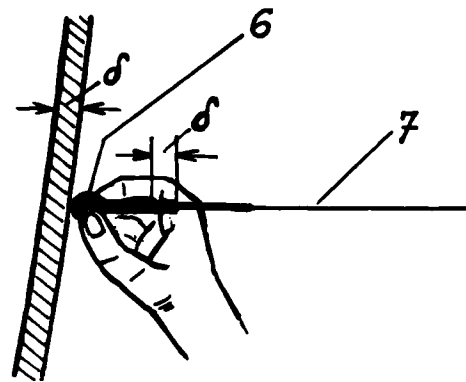

Figure 9.

If we consent to a small amount of intermediate work no reference line will be requested in this proceeding.

The matter stands thus:

The positioning of the pantograph consisted hitherto (Figure 1) in keeping constant the values or l_0 , ζ_0 , α_0 as well as in keeping the coincidence of the planes (plane of the section and working plane of the pantograph). Referring to Figure 10 we see that the constancy of l_0 and ζ_0 means the constancy of y_0 and z_0 . Coincidence of the planes means the constancy of β and γ . Hence of 6 possible freedoms of movement 5 of them (α , β , γ , y and z) had to be controlled and were embraced by the "positioning," while the sixth, i.e., the periodical shifting along the axis x , was loose. This shifting had also to be known, i.e., controlled but that was beyond the task of the positioning. The fulfilment of the conditions of the positioning led to a direct and complete plan of ship's lines (for example body plan) as the result of application of the pantograph.

The bulk of the positioning related to the reference line, hence to the control of the translations y_0 and z_0 (for the rotations, i.e., the angles α , β and γ were easily controllable by precise water levels fixed on the pantograph).

But what will be obtained if we renounce the

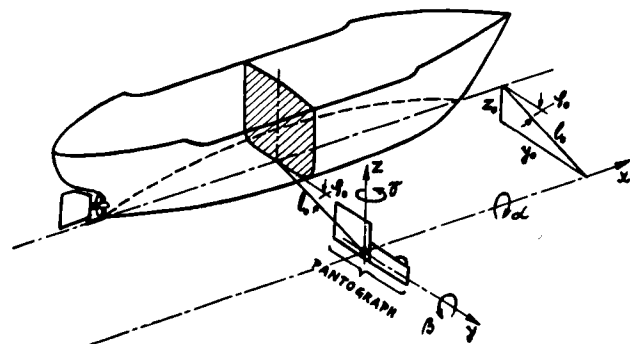

Figure 10.

control of y and z (y_0 and z_0), hence if we renounce the reference line as such and if we retain only the control of constancy of the angles α , β and γ ?

It is hardly necessary to say that in this case, too, all the graphs on the pantograph table will be drawn again in the same scale (reduction ratio has remained unchanged). The looseness of y and z will entail only some irregular translations of the graphs towards each other. Nevertheless, the constancy of angles will make that there will be no rotations of the graphs. Hence the result will be a number of scattered graphs on the table which are shifted only by translations and not by rotations.

Thus it remains to arrange the graphs in the drawing office. If the matter is of cross sections, the graphs of those sections pertaining to the straight portion of the keel (portion which is longer or at least equal to the parallel body) are to be arranged easily: their lowest points relating to the center line of the keel, these graphs have to be translated so that the mentioned points lie in one spot. As to the sections relating to the hull's portion beyond the straight part of the keel it is evident that the form of both stem and sternpost must also be taken down by reason of opening the possibility for arranging the graphs. Hence the whole center line of the ship must be taken down. If this line is drawn and if all the periodical shiftings of the pantograph x_i are also known, the arrangement of the graphs relating to sections beyond the straight portion of the keel offers no difficulty. Namely in this case distances are known of the lowest points of these graphs over the spot representing the straight portion of the keel and that is quite sufficient for the arrangement of individual graphs into a plan.

However, although there is no shortcoming on the part of the pantograph for taking down the center line of the hull, an obstacle is offered by the keel blocks which obviate the accessibility to the center line when doing in its plane. To avoid this obstruction we can take down any of the buttock and bow lines instead of the center line. If we know the distance B of these lines from the center line plane (Figure 11) and if also all the shiftings x_i made by taking down cross sections are known again, then the distances H_i are known of intersection points of the buttock and/or bow lines with cross sections from the horizontal line through the keel and that is quite sufficient for an appropriate arrangement of cross section graphs into a body plan.

Hence on behalf of two minor additional jobs—taking down one of the buttock and bow lines and subsequent arrangement of graphs into a plan—the puzzle of reference line marking and positioning of the pantograph as a whole is reduced to keeping only 3 angles α , β and γ constant and that is all.

It is hardly necessary to say that switching over from reference line variant of the proceeding to no-reference line one calls for no sort of modification to the pantograph itself.

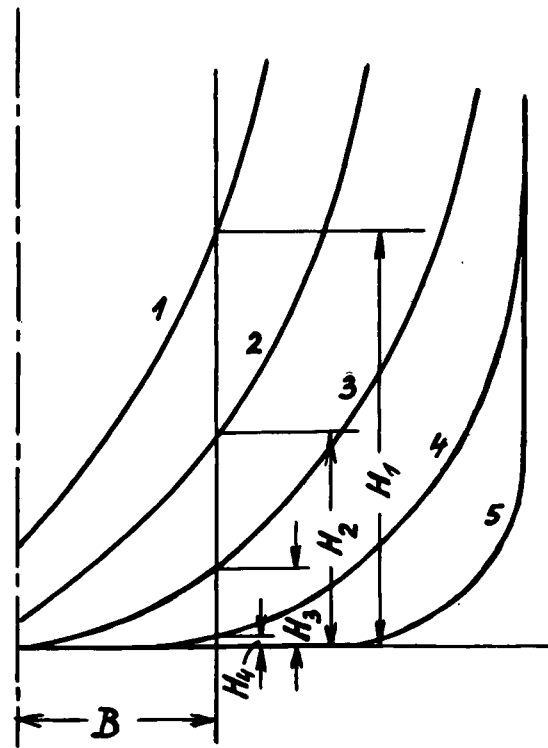

Figure 11.

The efficiency of the pantographic proceeding was substantiated clearly on the occasion of the trial applications of the prototype pantograph in the shipyard of Belgrade. Figures 12 and 13 show the pantograph and the proceeding itself. Full positioning of the pantograph by means of the reference line was used and although the team was inexperienced quite satisfactory body plans have been taken down in only a couple of hours. Somewhat more routine in the proceeding itself as well as some minor artisan improvements of the very pantograph would surely lead to still better results with regard to both speed and precision. Generally speaking the proceeding has proved to be very efficient and reliable.

Before ending it is necessary to mention that not only the forms of the ship's hulls can be taken down by the pantographic proceeding, but also the forms of other voluminous bodies, cavities, etc., can be determined by this proceeding. For example if the section lines of an underground gallery are to be taken down all what was said hitherto stands out also to this case completely. Only the table of the pantograph should be made all around the axis of the rule in order to enable it to operate on all 360 degrees of the circle and in addition to that also some minor modifications to the axle 3 of the pantograph should be made. But if one consents to take down one section in two or more turns and not at one pull this modification turns out to be unnecessary.

Turning again to ships we may remark that there

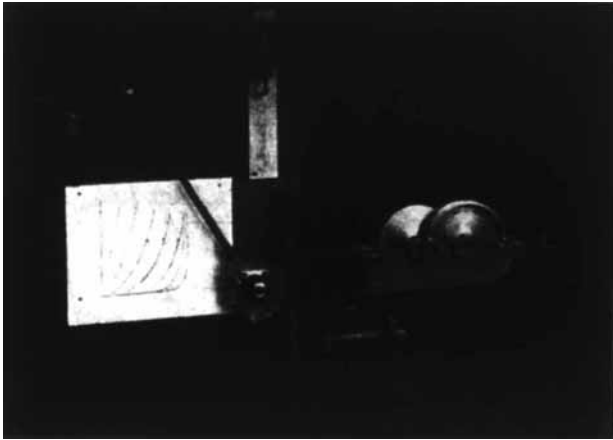

Figure 12. Pantograph.

are specific cases with them where also two or more turns are necessary for taking down one section line. Such is the case of the submarine where it is not possible to reach at once the whole half of the cross section from one positioning point of the pantograph. The measuring cable of the pantograph must be pulled tight freely so that only less than 180 degrees of the quasi-circular cross section of the submarine can be reached from one point. Hence in this case it is necessarily requested to take down lower and upper portions of one-half of the cross section separately from each other and to draw them together only subsequently in the drawing office.

A similar case is met with some river launches, especially with twin screw Kort-nozzle crafts where tunnel-like conduits of water to screws are formed in the stern. In this case the outer portion of the



Figure 13. Taking Down the Lines of a Ship's Body Plan.

cross section has to be taken down from a "normal" outside point, while the portion pertaining to the tunnel must be treated from a point situated inside the tunnel.

However, the bulk of both sea vessels and river craft relates to the normal case where only one positioning point is necessary for one cross section. Pantographic proceeding can readily be applied to all of them and also to many other non-shipyard cases. Whether the precise positioning of the pantograph, hence the reference line variant of the proceeding, or the no-reference line one is used, good lines drawings can be obtained by this proceeding quickly and reliably. Accordingly it is believed that by the development of the pantographic proceeding a proper contribution is made to the rather neglected problem of taking down the lines drawing from the ship herself.

The National Society of Professional Engineers has recently adopted a definitive policy on the use of engineering titles. This policy is to endorse the use by all employers and classifiers of a standard of qualification for an engineering title in position descriptions. To qualify for the title of engineer under N.S.P.E. standards, a person must fulfill one of the following requirements: he must be registered under a state engineering registration law; he must be a graduate of an accredited engineering curriculum; he must be covered by an official ruling under the Taft-Hartley or the Fair Labor Standards Acts, relative to an engineering position or professional status. Under this policy, persons engaging in engineering work, but not qualified under one of the above requirements, should be classified as engineering aides.