



Cryptography

Tuomas Aura
CS-C3130 Information security

Aalto University 2023

Outline

- Cryptographic hash function and HMAC
- Symmetric encryption
- Symmetric key and hash lengths
- Public-key signature
- Public-key encryption
- Diffie-Hellman key exchange
- Summary (notes about cryptography)

This lecture is intended mainly for those who are not taking a cryptography course yet

CRYPTOGRAPHIC HASH FUNCTION AND HMAC

Cryptographic hash
= message digest
= fingerprint

Legacy installer: [putty-0.67-ins](#)

Checksums for all the above files

MD5: [md5sums](#)

SHA-1: [shasums](#)

SHA-256: [sha256sums](#)

SHA-512: [sha512sums](#)

The latest development snapshot

Philip Zimmermann

Phil's Public Keys

For a copy of these keys you can import directly into PGP, click [here](#).

Current DSS/Diffie-Hellman Key:

Key fingerprint:

055F C78F 1121 9349 2C4F 37AF C746 3639 B2D7 795E

Older DSS/Diffie-Hellman Key:

Key fingerprint:

17AF BAAF 2106 4E51 3F03 7E6E 63CB 691D FAEB D5FC

```
$ git log
commit 9036c57ab9275f0e42f63a391ed68044f8c590bc
Author: raghunfs
Date: Fri Jul 1 07:44:23 2016 +0000
```

Handling error codes

```
commit 4d057be278eedce4e2c0682604d5304c7d18fb5a
Author: ms88 <ms88>
Date: Tue Jun 28 16:27:27 2016 +0300
```

fix fast reconnect



BLOCKCHAIN
info

Home

Charts

Stats

Markets

API

Wallet

Block #431985

Hashes

Hash	0000000000000000030166f5cadfc133e2e7474d880f9050f6503ac5c19edf45
Previous Block	000000000000000004247a0e018c3810c660fded6d35591b8a41fe0507ef012b

Cryptographic hash function



- The algorithm is public, no keys or other secrets needed
- Examples: SHA-256, SHA-512, SHA3-256

Cryptographic hash: security requirements

- **One-way = pre-image resistant**: given only output, impossible to compute input, except by guessing
- **Second-pre-image resistant**: given one input, impossible to find a second input that produces the same output
- **Collision-resistant**: impossible to find *any* two inputs with the same output
 - Old hash functions with broken collision resistance: MD5, SHA-1

Hash function implementation

Extra
material

- **Ideal hash function is a random, public function** chosen from the set of all byte strings (of any length) to bit-strings of fixed-length (e.g. $n=256$ bits)
 - Also called “**random oracle**”
 - In practice, impossible to store and share such infinite-size functions
- **Practical hash function is pseudorandom**: deterministic algorithm, but output looks random
 - **One-way, collision resistant**
 - Efficient to compute for large inputs
 - Typically algorithm based on And, Xor, Rot, Add (mod 2^{32}) operations

Hash function applications

- Integrity check on stored files, software downloads, or any data – compute hash and compare with known correct value
- Unique, “self-certifying” identifier for any object, e.g. file, public key, Bitcoin block
- Key derivation and password storage, e.g. PBKDF2
- Signing: sign the hash of the message with RSA
- Message authentication with HMAC and a shared secret key

Hash collisions

Extra
material

- Research has found collisions in several standard hash functions
 - MD5, SHA-1
 - Applications should be designed for **crypto agility** i.e. easy upgrading of functions
- **Where and why is collision resistance needed?**
(or is preimage and second-preimage resistance sufficient?)
 - File integrity check?
 - Software integrity check?
 - Digital signature on a contract?
 - MAC for end-to-end authentication?
 - Password storage?
 - Key derivation in Wi-Fi?
 - Bitcoin?
- Not all applications need collision resistance, but many do in subtle ways

Message authentication code (MAC)

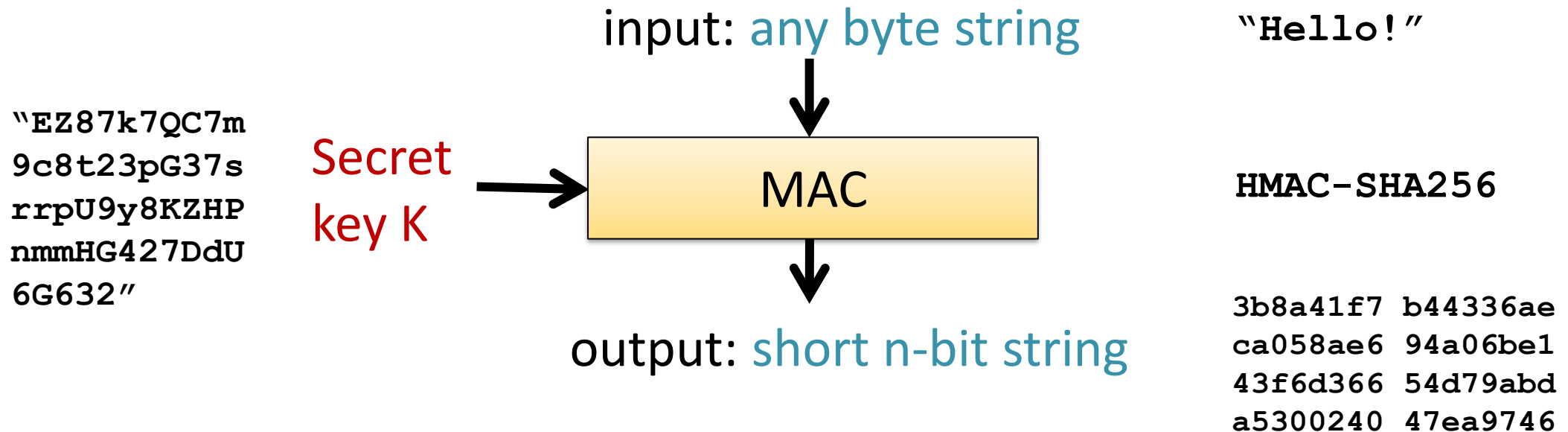

- **Secret key** is needed to create and to check the MAC
- **HMAC** is a standard way to construct a MAC from a hash function, e.g. HMAC-SHA256

Message authentication with MAC

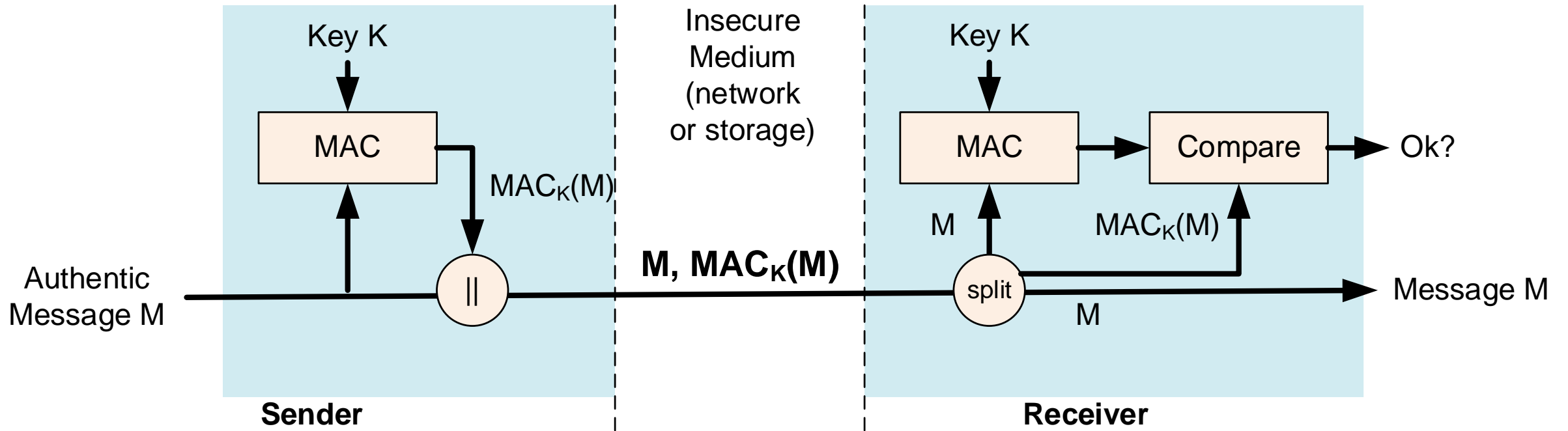

- Message authentication and integrity protection
- Endpoints **share the secret key K** (thus, it is **symmetric cryptography**)
- MAC is appended to the original message **M**

HMAC details

Extra
material

- HMAC is commonly used in standards:
 - Way of deriving MAC from a cryptographic hash function h
$$\text{HMAC}_K(M) = h((K \oplus \text{opad}) \mid h((K \oplus \text{ipad}) \parallel M))$$
 - Hash function h is instantiated with SHA-1, MD5 etc. to produce HMAC-SHA-1, HMAC-MD5,...
 - \oplus is XOR; \mid is concatenation of byte strings
 - ipad and opad are bit strings for padding the key to fixed length
 - Details: [RFC 2104][Bellare, Canetti, Krawczyk Crypto'96] [*](#)
- HMAC is theoretically stronger than simpler constructions, e.g.
 $h(M \parallel K)$

Hash and HMAC commands

Compute the hash of a file

```
echo "Attack at sunrise!" > m.txt
```

```
sha256sum m.txt
```

```
openssl dgst -sha256 m.txt
```

Append a LF to the file and see if the hash changes

```
echo >> m.txt
```

```
openssl dgst -sha256 m.txt
```

Compute HMAC using hash of "abc123" (bad!) as the key

```
openssl dgst -sha256 -hmac abc123 m.txt
```

Change the key slightly and see if the hash changes

```
openssl dgst -sha256 -hmac abc132 m.txt
```

SYMMETRIC ENCRYPTION

Symmetric encryption

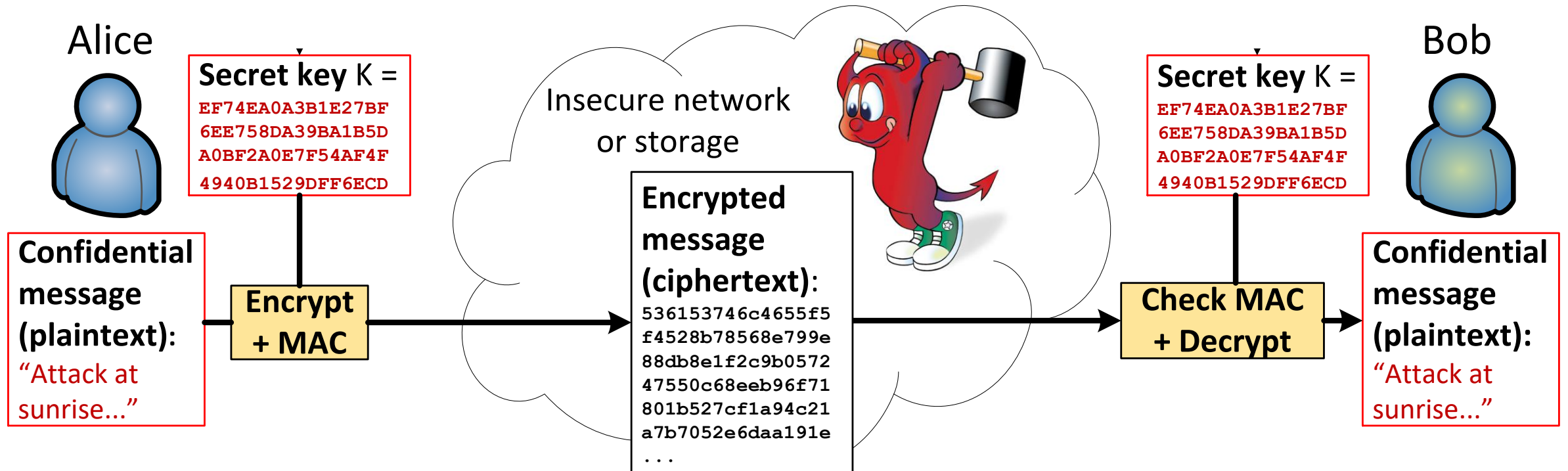

- Message encryption based on **symmetric cryptography**, i.e. a **shared secret key**

Symmetric encryption

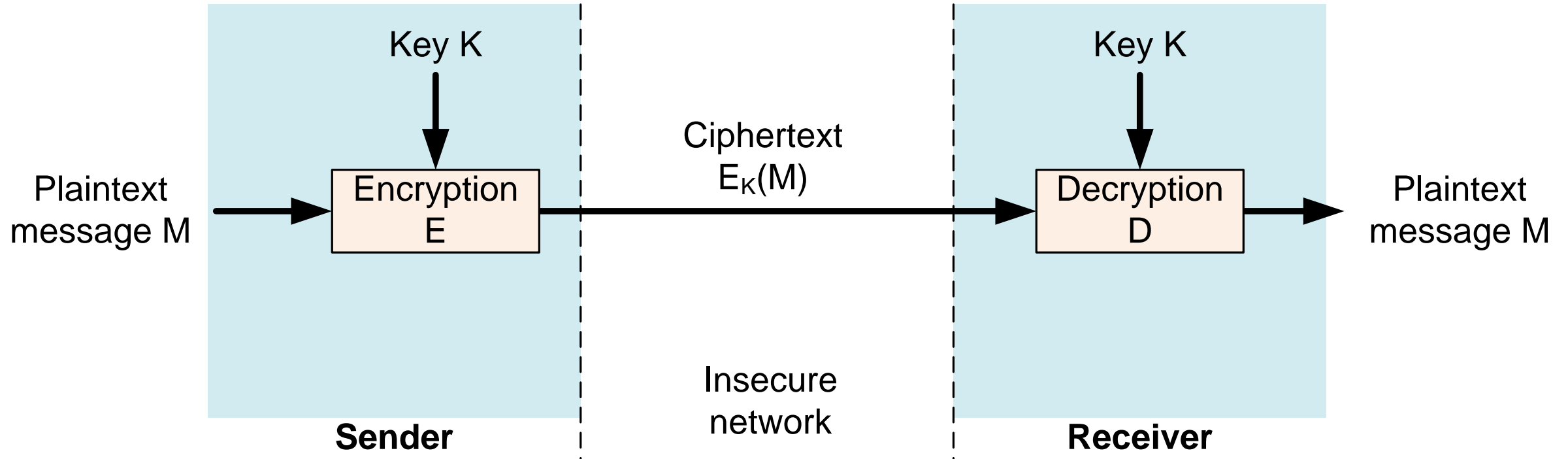

- Message encryption based on **symmetric cryptography**, i.e. a **shared secret key**

Symmetric encryption

- **Kerckhoff's principle**: the encryption and decryption algorithms are public algorithms; only the key is secret
- Encrypted message content looks like random bits – unless you know the key
- The key must be shared over a secure **out-of-band channel**
 - a 128...256-bit random number
 - sometimes computed from a passphrase with a cryptographic hash function (should use PBKDF2 to make cracking slower)

Symmetric encryption

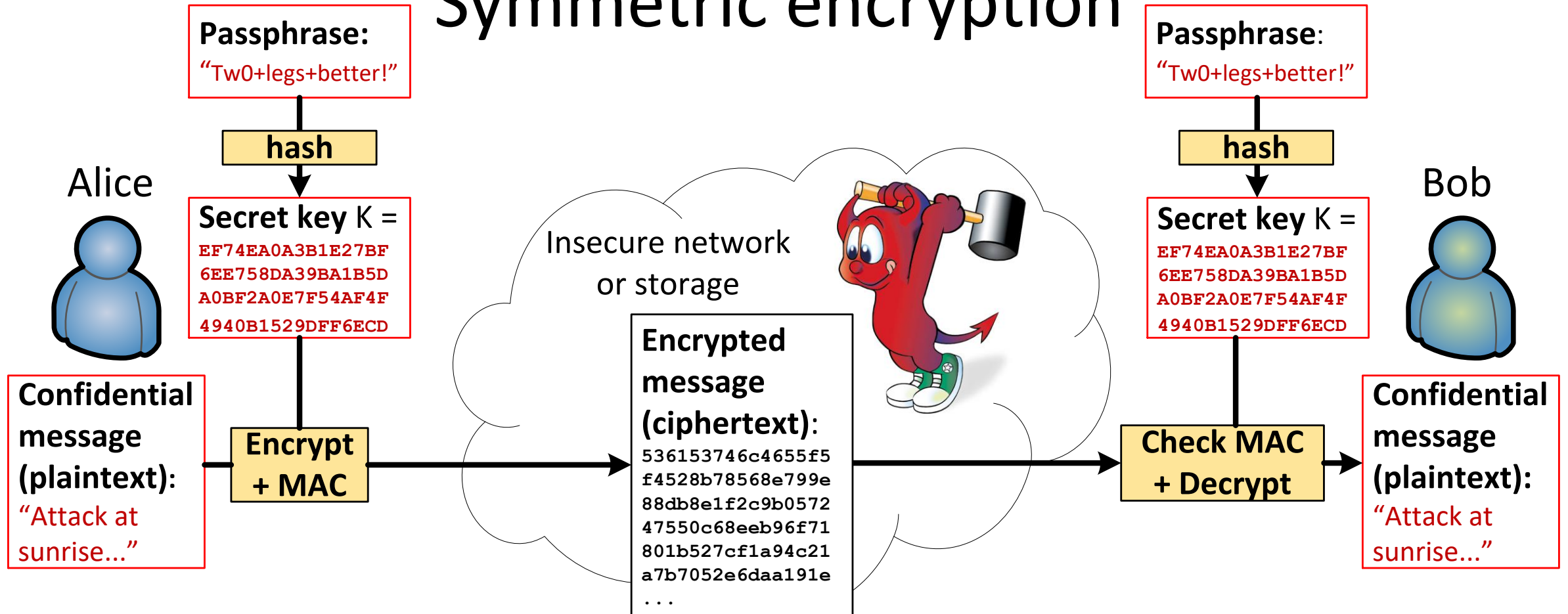

- Message encryption based on **symmetric cryptography**, i.e. a **shared secret key**

Block cipher and cipher mode

- **Block cipher** is the basic construction block for encryption
 - Encryption of a fixed-length block, typically 128 bits
 - Examples: **AES**, 3DES
- **Cipher mode** uses the block cipher as building block for encrypting messages of any length
 - **Padding** of the message to full blocks
 - **Initialization vector**, so that the same plaintext always produces a different ciphertext (called **salt** in OpenSSL commands)
 - Example: **cipher-block chaining (CBC)**

Symmetric encryption with OpenSSL

Create a plaintext message (length multiple of 128 bits).

```
echo "Secret meeting in the usual place at 10 am xxxx" > m.txt
hexdump -C m.txt
```

Encrypt with block cipher.

```
openssl enc -aes-256-cbc -nosalt -nopad -k abc123 -in m.txt -out m.enc
cat m.enc
hexdump -C m.enc
```

Note how random the ciphertext looks. Then, decrypt and compare.

```
openssl enc -d -aes-256-cbc -nosalt -nopad -k abc123 -in m.enc -out r.txt
hexdump -C r.txt
```

Try also decrypting with a different key.

Edit the ciphertext slightly and decrypt again. The plaintext may change only partly.

Normally, encryption uses salt (or IV) and padding: The salt is random, not secret, and stored with the ciphertext. The message is padded to full 128-bit blocks.

```
echo "Secret meeting in the usual place at 10 am." > m.txt
hexdump -C m.txt
openssl enc -aes-256-cbc -k abc123 -in m.txt -out m.enc
hexdump -C m.enc
openssl enc -d -aes-256-cbc -k abc123 -in m.enc -out r.txt
hexdump -C r.txt
```

Edit one byte of the ciphertext and decrypt again.

OpenSSL computes the key (and IV) from with PBKDF2 from the passphrase and salt.

If we encrypt the same message again, thanks to the salt, the ciphertext looks different.

```
hexdump -C m.enc
openssl enc -aes-256-cbc -k abc123 -in m.txt -out m.enc
hexdump -C m.enc
```

Encrypted files are binary. To send over email or http, they are usually base64 encoded.

```
openssl enc -aes-256-cbc -base64 -k abc123 -in m.txt -out m.enc
cat m.enc
```

Encryption and message integrity

- Encryption alone protects secrets, not integrity

- Attacker can usually modify the secret message
- Receiver of the modified secret message usually leaks some information, e.g. error in message

- ➔ Always combine encryption with integrity protection

- **Encrypt-then-MAC**: encrypt with block cipher e.g. in CBC mode, then compute and append a MAC
- **Authenticated encryption** modes do encryption and integrity in one pass, e.g. **AES-GCM**

If in doubt, use **Authenticated encryption with associated data (AEAD)**

SYMMETRIC KEY AND HASH LENGTHS

Key length (1)

- Shared key of ≥ 128 bits is strong, < 80 bits is weak
 - To resist brute-force guessing, the secret key must be random with (almost) even probability distribution
 - Quantum cryptanalysis may require keys of 256 bits in the future
 - Q: Why is a secret key of 1000 bits on 1 MB not better than 256?

Number of atoms in the earth is less than $10^{50} \approx 2^{166}$.

Age of the universe $4.3 \cdot 10^{17} \approx 2^{59}$ seconds $\approx 2^{89}$ nanoseconds.

$2^{166} \cdot 2^{89} \leq 2^{256}$.

→ 256-bit keys definitely cannot be brute-forced

Key length (2)

- Brute-force attacks are easy to parallelize; thus, **cost should never be measured in time but in money** (EUR, USD, CPU days)
 - 1 CPU day = \$1 on high-end PC, less on cloud infrastructure
 - Q: If NSA has a billion-dollar computer and can break DES encryption keys in 1 second, how much does it cost for you to break them on Amazon EC2?
- Strength of a key derived from passphrase?
 - $K = \text{SHA-256}(\text{"verYsekReTT123pasSfraZe"})$
 - Dictionary attack to guess human-invented passphrases is possible, while brute-forcing a random 128 or 256-bit key is not

Hash length and birthday paradox

- **How long hash values?** Answer: **256..512 bits**
- One-wayness and second preimage resistance require has length of 128..256 bits. Why?
 - Attacker tries different inputs to match a known hash value.
Impossible to perform 2^{128} hash computations
- **Collision resistance requires almost twice that length.** Why?
- **Birthday attack:** *store* computed hash values and find a match between *any two* of them

Hash length and birthday paradox (2)

- Rule of thumb: When randomly sampling a set of M values, collisions appear after $M^{1/2}$ (square root of M) samples

(More precisely: for large M , the collision probability is 50% at $(2 \cdot \ln 2 \cdot M)^{1/2} \approx 1.18 \cdot M^{1/2}$ samples.)

- Same rule in different words:
 - When randomly sampling a set of 2^N values, collisions appear after $2^{N/2}$ samples
 - If attacker can compute and store 2^N hash values, it can find collisions for hash values of length $2 \cdot N$ bits
 - If an N -bit hash value is safe against brute-force reversing, nearly $2 \cdot N$ bits are needed to avoid collisions with birthday attack (“nearly” because brute-force reversing requires only CPU but the birthday attack requires also storage)

HOW DOES ENCRYPTION WORK?

– BLOCK CIPHERS

Please read this section for a rough idea of how a block cipher works. More details in a cryptography course

Ideal encryption: random permutation

Extra
material

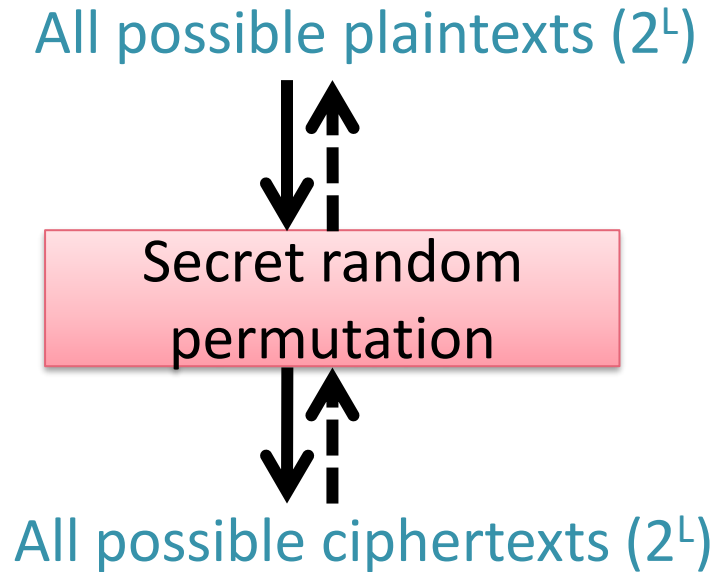

- Messages = bit strings with some maximum length L
- Ideal encryption would be a random **1-to-1 function** i.e. **permutation** of the set of all possible messages to itself
- Decryption is the reverse function
- Like an old-fashioned military **code book**, but *much* larger
- Impossible to store and share: table with 2^L rows

Real encryption: pseudorandom permutation

Extra
material

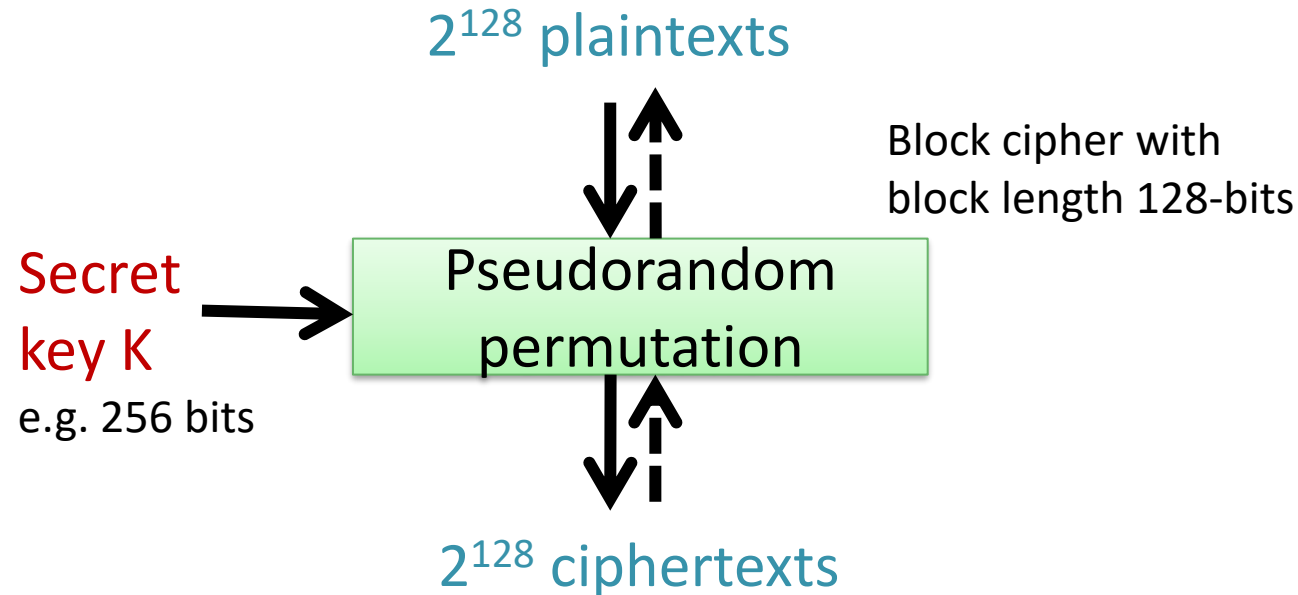

- **Block cipher:** string length fixed usually to $L=128$ bits
 - **Pseudorandom permutation** that depends on a **secret key** of 128..256 bits
 - Number of different permutations is 2^{256} , large but far less than $(2^L)!$
- **Pseudorandom** = indistinguishable from random unless you know the algorithm and key
- **Kerckhoff's principle:** public algorithm, secret key

Substitution-permutation network

Extra material

- One way to implement a **key-dependent pseudorandom permutation**
- Substitution-permutation network:
 - **S-box = substitution** is a small (random) 1-to-1 function for a small block, e.g. $2^4 \dots 2^{16}$ values
 - **P-box = bit-permutation** mixes bits between the small blocks
 - Repeat for many **rounds**, e.g. 8...100
 - Mix **key bits** with data in each round
 - Decryption is the reverse
- **Cryptanalysis** tries to detect minute differences between this and a true random permutation

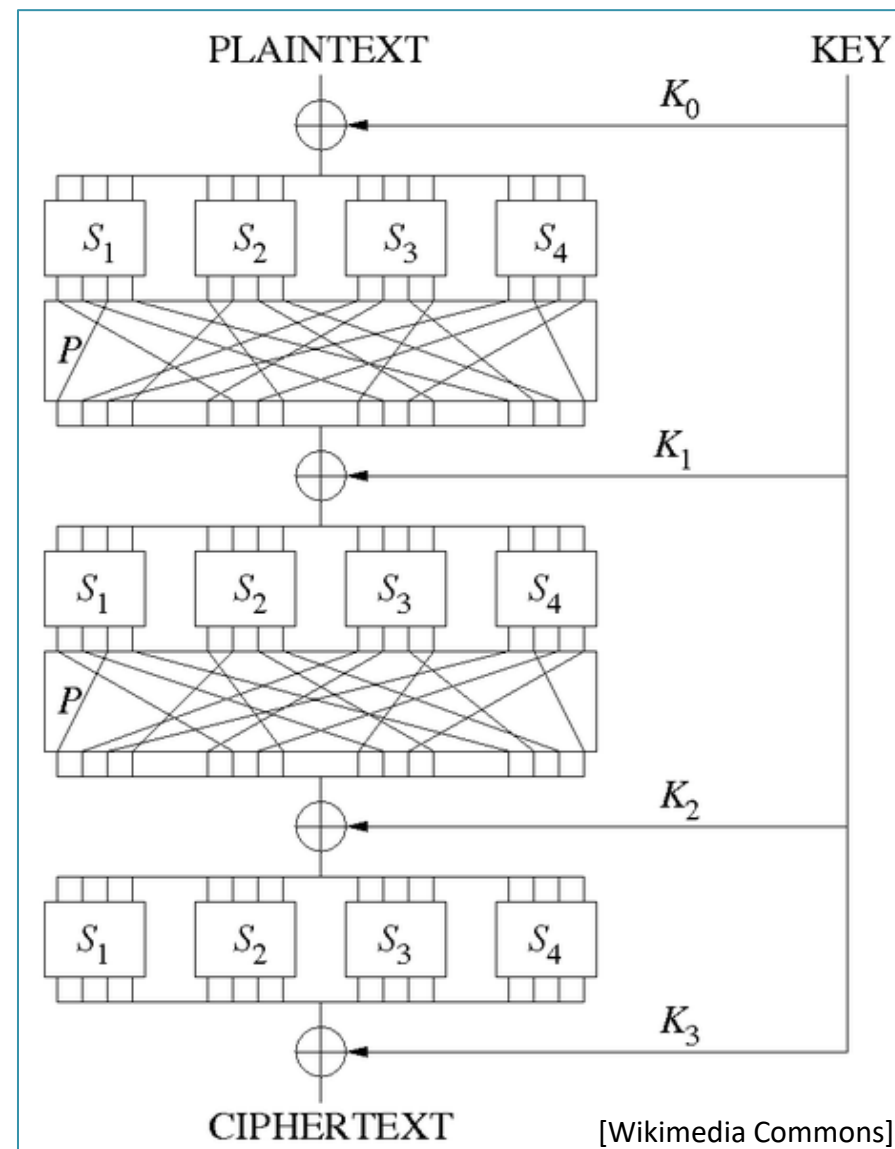

Cipher design

Extra
material

- It is not difficult to make strong block cipher: long key, large S-boxes, many many rounds
- Good block ciphers are not only strong
 - fast to compute in software
 - require little memory
 - cheap to implement in hardware
 - optimized for both throughput and latency
 - use a short (e.g. 128-bit) key, which is expanded to the round keys, but still allow fast key changes
 - no unexplained features that could be a backdoor
 - implementation is resistant to side-channel attacks
 - etc.
- The difficulty is in finding a **balance between performance and security**

AES

Extra
material

- **Advance Encryption Standard (AES)**
 - Standardized by NIST in 2001
 - 128-bit block cipher
 - 128, 192 or 256-bit key
 - 10, 12 or 14 rounds
- **AES round:**
 - **SubBytes**: 8-byte S-box, not really random, based on finite-field arithmetic, multiplication in $GF(2^8)$
 - **ShiftRows** and **MixColumn**: reversible linear combination of S-box outputs (mixing effect similar to P-box)
 - **AddRoundKey**: XOR bits from expanded key with data
- **Key schedule**: expands key to round keys

Cipher mode example

Extra
material

- **Block-cipher mode**, e.g. **cipher-block chaining (CBC)**, is used for encrypting longer messages

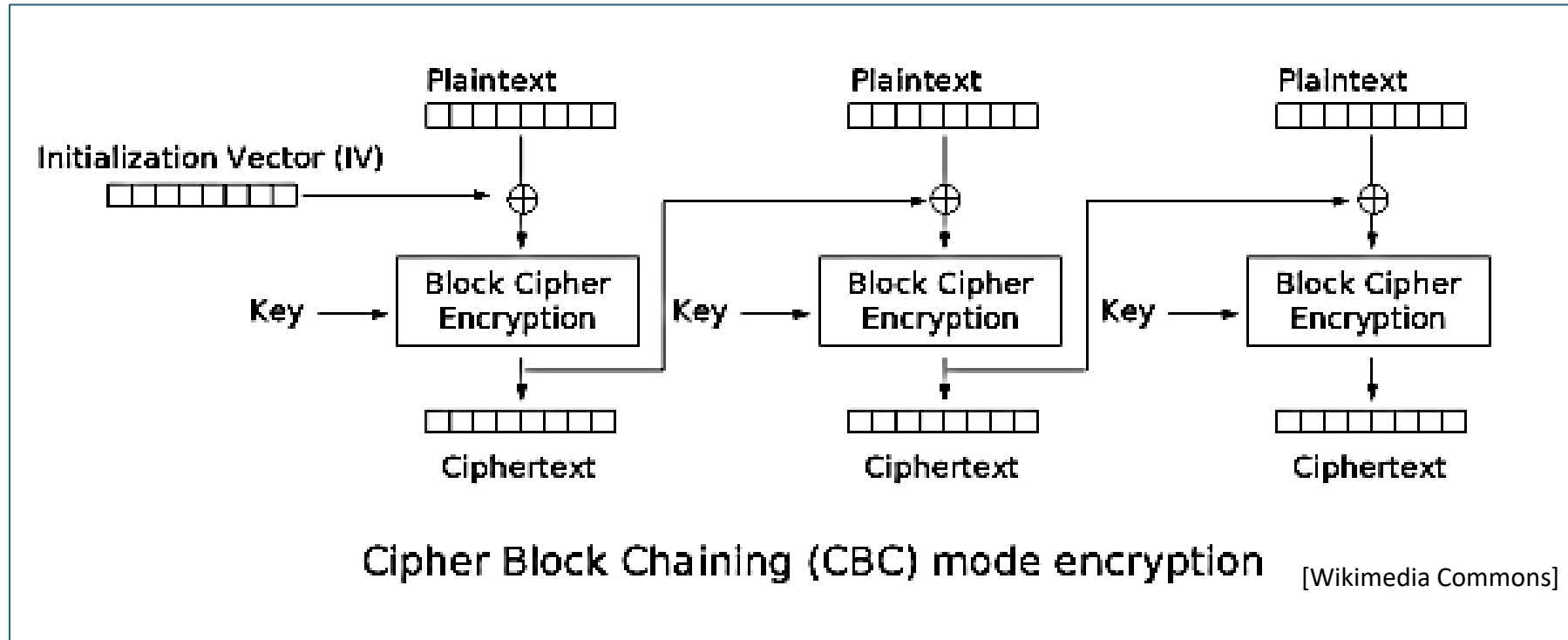

- **Initialization vector (IV)** makes ciphertexts different even if the message repeats. It may be a non-repeating counter or a random number that is also sent to the receiver. IV is not secret
- The message is padded to fill full blocks of the block cipher

Common ciphers and modes

Extra
material

- **Block ciphers:**
 - DES — old standard, 56-bit keys now too short, 64-bit block
 - 3DES in EDE mode: $DES_{K3}(DES_{-1K2}(DES_{K1}(M)))$, 3x56 key bits
 - AES — at least 128-bit keys, 128-bit block
- **Block-cipher modes**
 - E.g. electronic code book (ECB), cipher-block chaining (CBC)
- **Stream ciphers:**
 - XOR plaintext and a keyed pseudorandom bit stream
 - RC4: simple and fast software implementation
- **Most encryption modes are malleable: attacker can make controlled modifications to the plaintext**
 - E.g. consider CBC mode or stream cipher
- **Authenticated encryption modes combine encryption and integrity check**

ASYMMETRIC CRYPTOGRAPHY: DIGITAL SIGNATURE

Digital signature

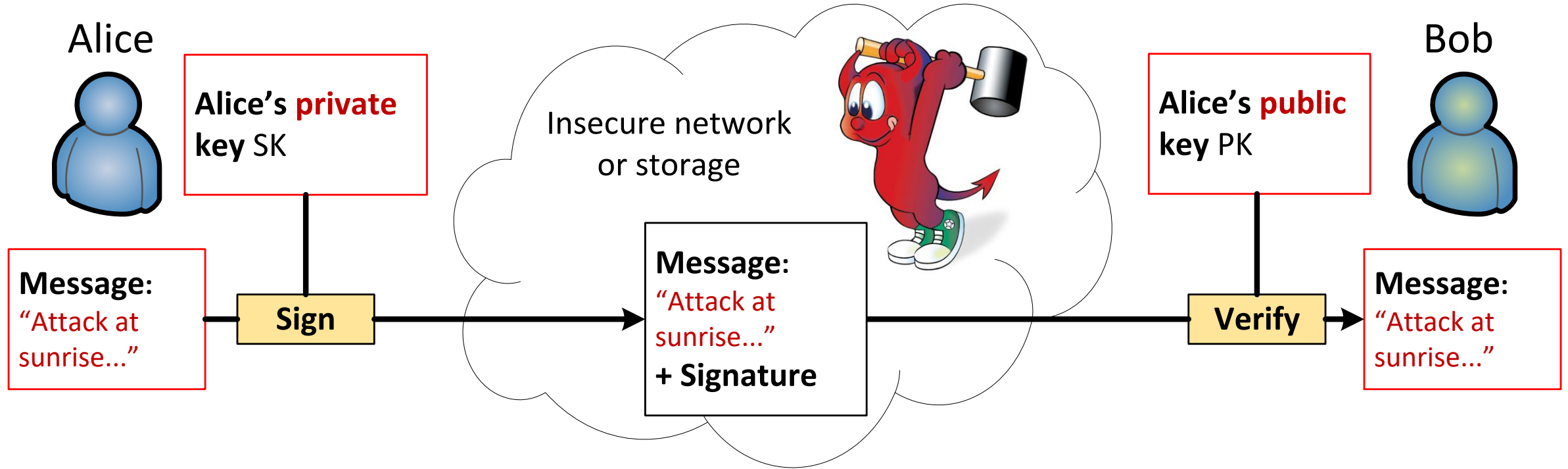

- Message authentication and integrity protection
- Asymmetric i.e. public-key cryptography
- **Key pair** with public and private parts

RSA signature with GPG

```
# Generate a key pair
gpg --gen-key
# Note the key fingerprint.
# Take a look at the keys
ls ~/.gnupg/
gpg --fingerprint
gpg --export -a "Tuomas Aura" > tuomas.key
# Sign a message and check the signature
echo "Attack at sunrise!" > m.txt
hexdump -C m.txt
gpg --sign -v -u "Tuomas Aura" m.txt
hexdump -C m.txt.gpg
gpg < m.txt.gpg
# Note that the message is not encrypted
hexdump -C m.txt.gpg
# Encoding for inclusion in email etc.
gpg --sign --armor -v -u "Tuomas Aura" m.txt
less m.txt.asc
gpg < m.txt.asc
# More readable but fragile message with --clearsign
gpg --clearsign -v -u "Tuomas Aura" m.txt
less m.txt.asc
```

Digital signature

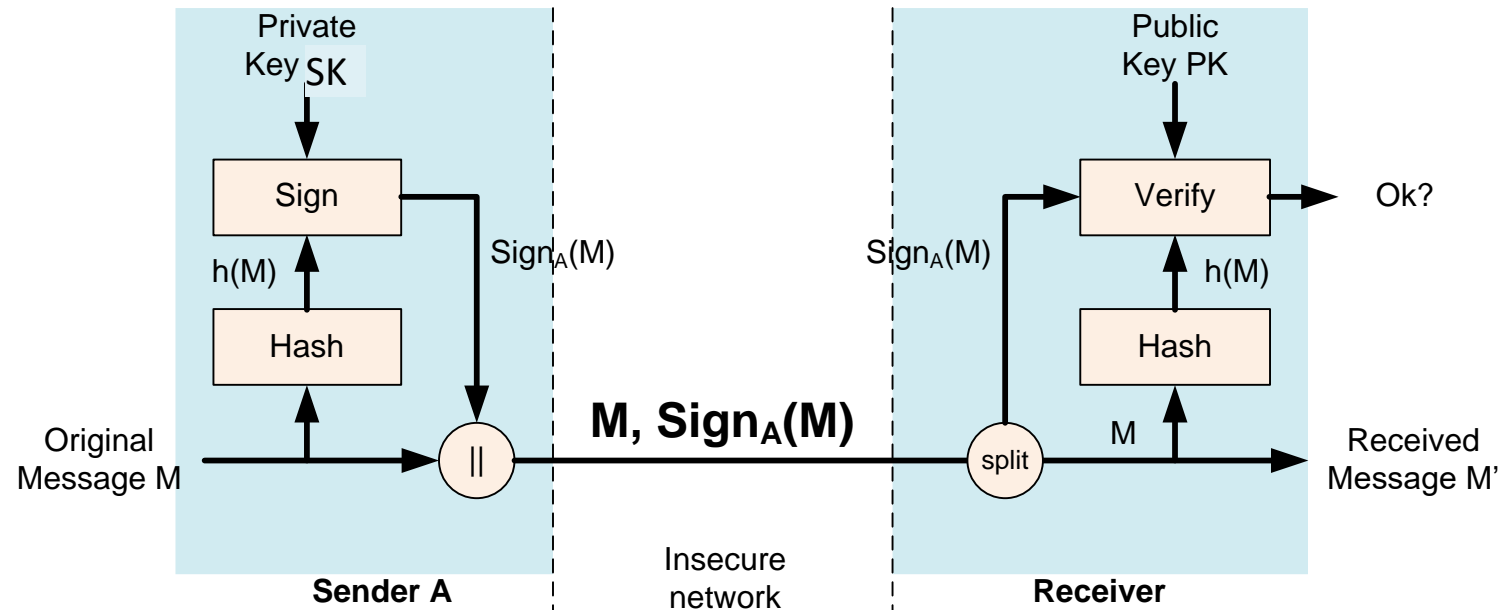

- Message authentication and integrity protection with **public-key** crypto
 - Verifier has a public key PK ; signer has the private key SK
 - Messages are first hashed and then signed
 - Examples: DSS, RSA + SHA-256, ECDSA

Digital signature issues

- Always follow strictly the standard when implementing signatures!
There are many subtle points that can go wrong
 - Examples: DSA, RSA [PKCS#1]
- **Signing is not encryption with public key!**
 - Common misconception because the RSA private key can be used both to sign and decrypt
- Digital signature “with appendix”
 - Hash the message, sign the hash
 - The signature is usually appended to the actual message but can also be stored separately
- Question: what consequences if you use a broken hash function with known collisions (e.g. SHA-1) for signing?

PUBLIC-KEY ENCRYPTION

Public-key encryption

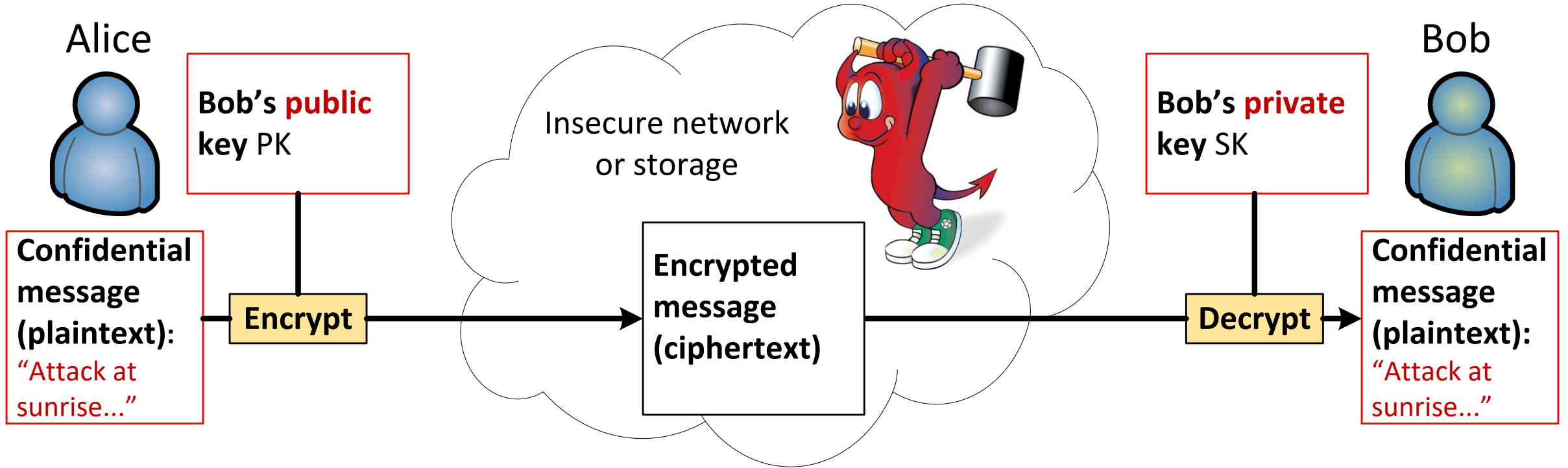

- Asymmetric encryption: public key and private key
- Protects secrets, not integrity

RSA encryption with GPG

Sign and encrypt a message

```
gpg --encrypt --sign -u "Tuomas Aura" -r "Test User" m.txt  
hexdump -C m.txt.gpg
```

Open a received message

```
gpg confidential.asc
```

Here is how Test User signed and encrypted it:

```
gpg --encrypt --sign --armor -u "Test User" -r "Tuomas Aura" --output  
confidential.asc letter.txt
```

Public-key encryption

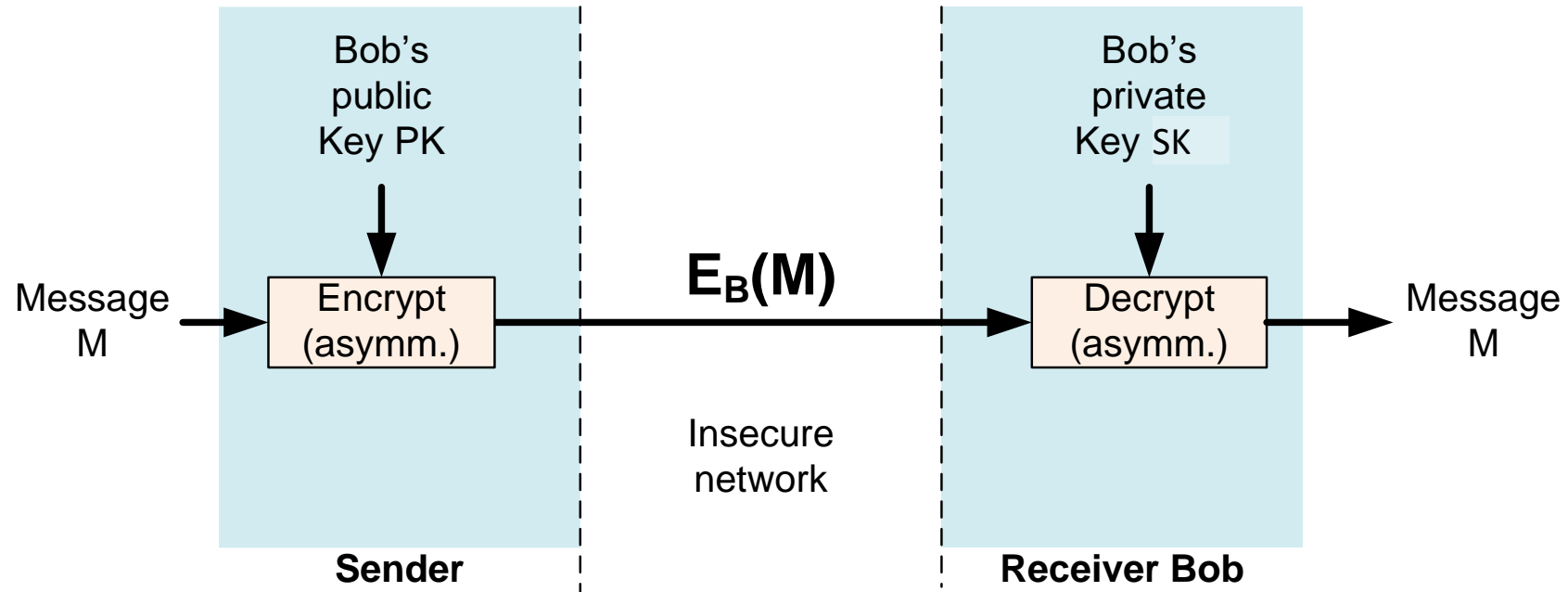

- Message encryption based on **asymmetric** cryptography
 - Key pair: **public key** and **private key**
- **Protects secrets, not integrity**

Hybrid encryption

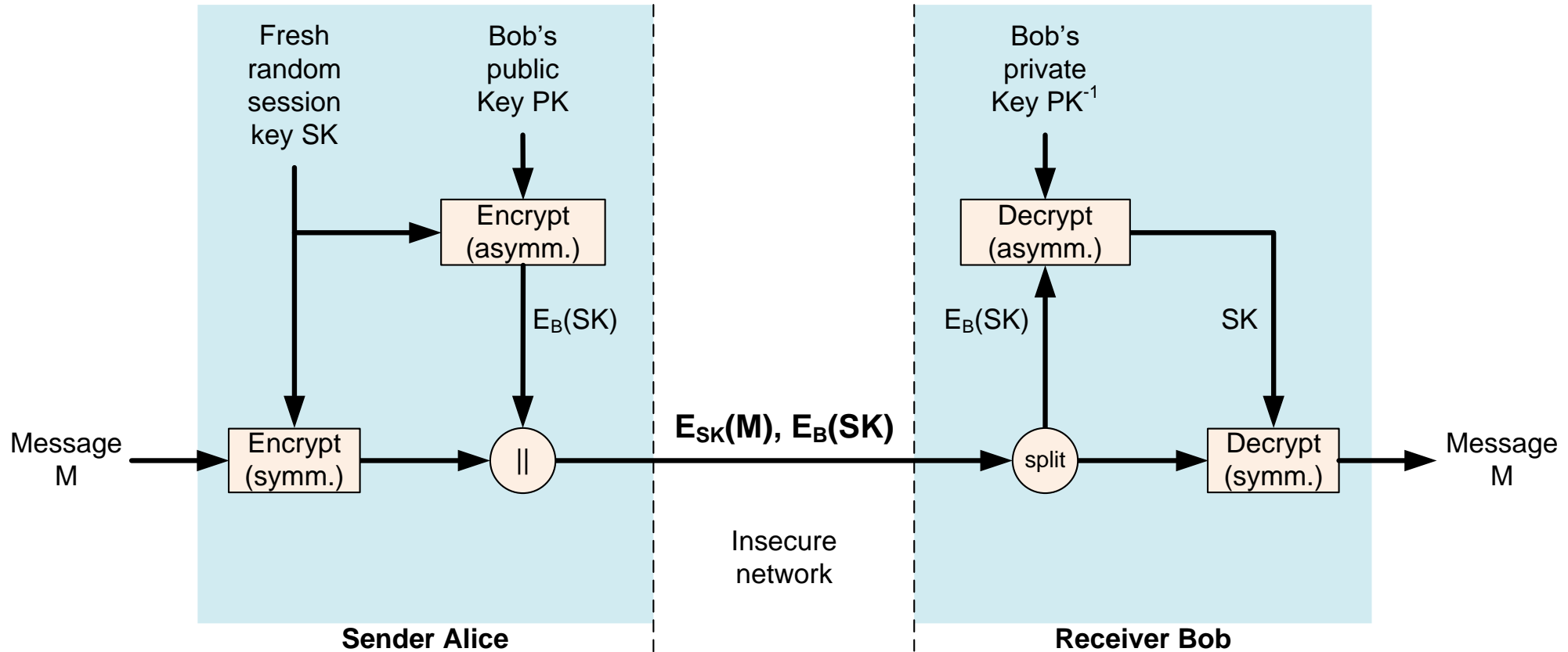

- Symmetric encryption is fast; asymmetric is convenient
- Hybrid encryption = symmetric encryption with random session key + asymmetric encryption of the session key

Key distribution



- The advantage of public-key cryptography is easier **key distribution**
- Shared secret keys, symmetric cryptography:
 - $O(N^2)$ pairwise keys for N participants \rightarrow does not scale
 - Keys must be kept **secret** \rightarrow hard to distribute safely
- Public-key protocols, asymmetric cryptography:
 - N key pairs needed, one for each participant (or $2 \cdot N$ if different key pairs for encryption and signature)
 - Public keys are **public** \rightarrow can be posted on the Internet

But... both shared and public keys must be authentic

How does Alice know she shares K_{AB} with Bob, not with Eve?

How does Alice know PK_B is Bob's public key, not Eve's?

RSA encryption details

Extra
material

- **RSA encryption**, published 1978
 - Based on modulo arithmetic with very large integers
- **Simplified** description of the algorithm:
 - Public key (e,n) - public exponent and modulus
 - Private key (d,n) - secret exponent and public modulus
 - Encryption $C = M^e \bmod n$
 - Decryption $C^d \bmod n = (M^e)^d \bmod n = M$
 - n is commonly 1024 or 2048 bits long, d will also be long, e can be short (17 or $2^{16}+1$); M can be at most as long as n
- **Why does it work? Based on number theory**
 - Euler's totient function $\phi(n)$, number of integers $1..n$ that are relatively prime with n
 - Euler's theorem: $x^{\phi(n)} \equiv 1 \pmod{n}$, and thus $x^{k\phi(n)+1} \equiv X \pmod{n}$
 - We need to have e and d so that $ed = k\phi(n)+1$ for some k
 - Key pair generation:
 1. Choose n as product of two large secret prime numbers $n=pq$; then, $\phi(n)=(p-1)(q-1)$
 2. Then pick a small e ($e=17$ or $e=2^{16}+1$), solve d with the extended Euclidian algorithm
 3. Forget $p,q,\phi(n)$
 - **RSA security assumption**: difficult to solve d when you only know (e,n) (this is assumed to be about as difficult as factoring n without being told p and q)
- For details and implementation guidelines, see [PKCS#1](#)
Never implement RSA without following such a standard!

Goal here is to give a quick feel of how RSA works, not to understand it all

Example: RSA public key

Extra material

ASN.1
type tags

30	82	01	0a	02	82	01	01	00	c7	3a	73	01	f3	2e	a8
72	25	3c	6b	a4	14	54	24	e7	e0	ab	47	2e	9f	38	a7
12	77	dc	cf	62	bc	de	47	a2	55	34	a6	47	9e	d6	13
90	3d	9f	72	aa	42	32	45	c4	4a	b7	88	cc	7b	c5	a6
18	4f	d5	86	a4	9e	fb	42	5f	37	47	53	e0	ff	10	2e
cd	ed	4a	4c	a8	45	d9	88	09	cd	2f	5f	7d	b6	9b	40
41	4f	f7	a9	9b	7a	95	d4	a4	03	60	3e	3f	0b	ff	83
d5	a9	3b	67	11	59	d7	8c	aa	be	61	91	d0	9d	5d	96
4f	75	39	fb	e7	59	ca	ca	a0	63	47	bd	b1	7c	32	27
1b	04	35	5a	5e	e3	29	1a	06	98	2d	5a	47	d4	05	b3
22	3f	fd	43	38	51	20	01	ad	1c	9e	4e	ad	39	f4	d1
ae	90	7d	f9	e0	81	89	d2	b7	ba	cd	68	2e	62	b3	d7
ad	00	4c	52	24	29	97	37	8c	6e	36	31	bd	9d	3d	1d
4c	4c	cc	b0	b0	94	86	06	9c	13	02	27	c5	7c	1e	2e
f6	e3	f6	13	37	d9	fb	23	9d	e7	c7	d5	ce	94	54	7d
ef	ef	df	7b	7b	79	2e	f9	75	37	8a	c1	ef	a5	c1	2a
01	e0	05	36	26	6a	98	bb	d3	02	03	01	00	01		

2048-bit
modulus

ASN.1
type tags

public exponent
($2^{16}+1$)

Key length in asymmetric crypto

- In RSA, secure key lengths are ≥ 2048 bits
- Elliptic-curve cryptography (ECC):
public-key crypto with much shorter keys and efficient computation, ≥ 256 bits
 - Used for most new applications and small devices

Formal security definitions

- Cryptographic security definitions **for asymmetric encryption**
- **Semantic security** (security against passive attackers)
 - Computational security against a ciphertext-only attack
- **Ciphertext indistinguishability** (active attackers)
 - **IND-CPA** — attacker submits two plaintexts, receives one of them encrypted, and is challenged to guess which it is \Leftrightarrow semantic security
 - **IND-CCA** — indistinguishability under *chosen ciphertext* attack i.e. attacker has access to a decryption oracle before the challenge
 - **IND-CCA2** — indistinguishability under *adaptive* chosen ciphertext attack i.e. attacker has access to a decryption oracle before and after the challenge (except to decrypt the challenge)
- **Non-malleability**
 - Attacker cannot modify ciphertext to produce a related plaintext
 - $\text{NM-CPA} \Rightarrow \text{IND-CPA}$; $\text{NM-CCA2} \Leftrightarrow \text{IND-CCA2}$
- It is non-trivial to choose the right kind of encryption for your application; ask a cryptographer!

DIFFIE-HELLMAN KEY EXCHANGE

Diffie-Hellman key exchange

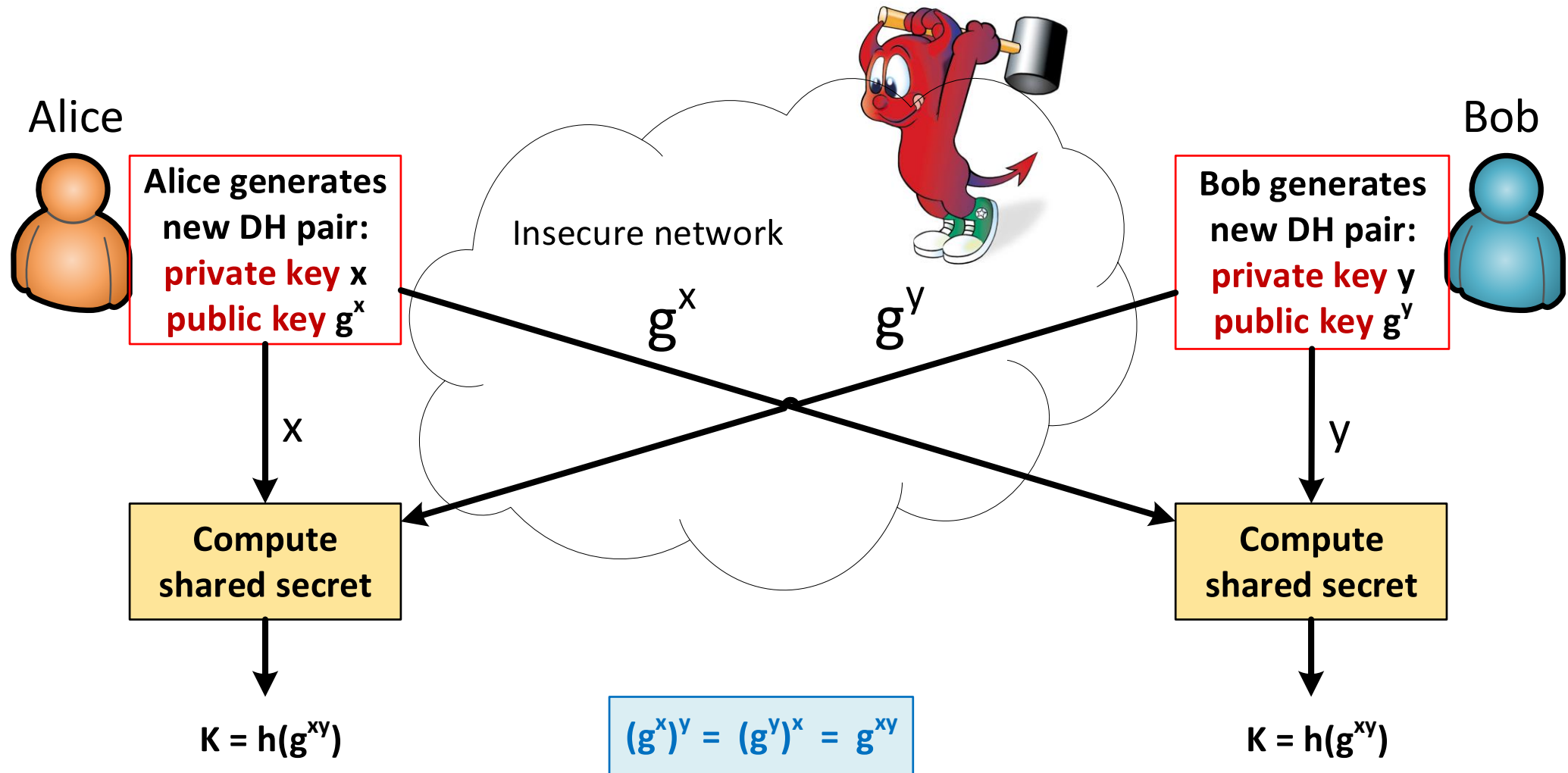

Diffie-Hellman key exchange

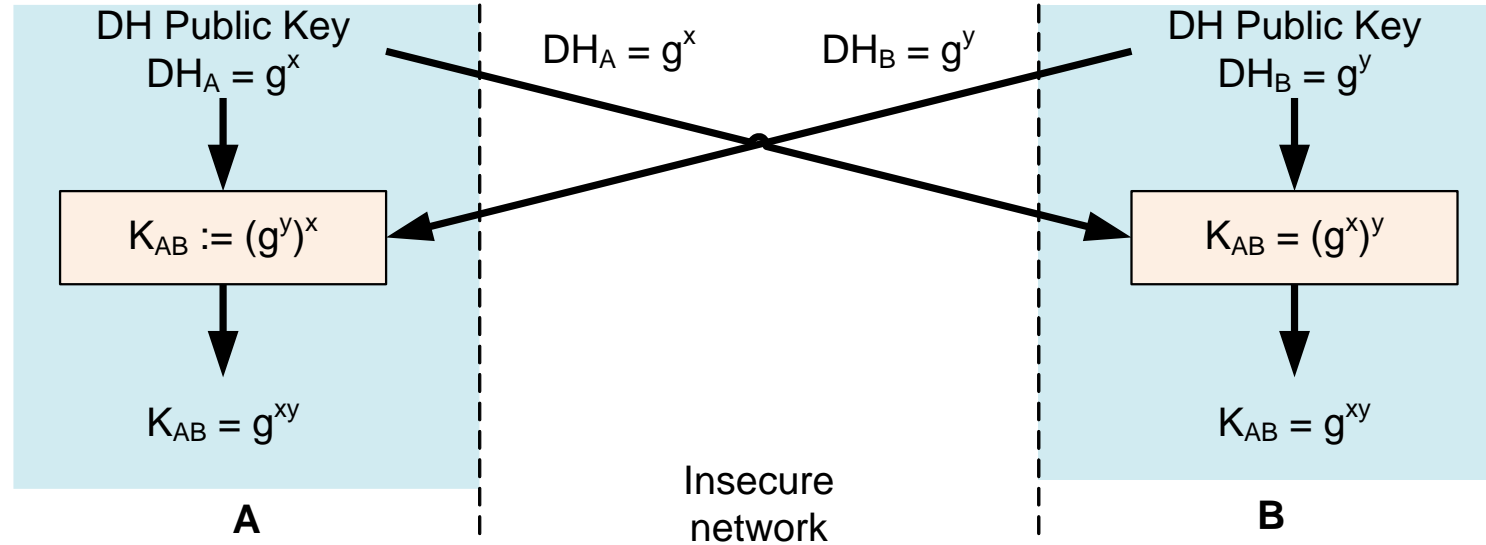

- Both sides compute the same session key
- **Passive attacker** listens to communication but cannot compute the key

Diffie-Hellman key exchange

- Creating a shared key based on **commutative** operation, such as exponentiation modulo p :

$$(g^x \bmod p)^y \bmod p = (g^y \bmod p)^x \bmod p$$

- Diffie-Hellman assumption: **given g , p , g^x and g^y , it is infeasible to solve g^{xy}**
 - Security depends on the difficulty of the **discrete logarithm problem**, i.e. solving x from $(g^x \bmod p)$ when p is large
- **Elliptic curve Diffie-Hellman** uses commutative operations in a different field

Impersonation attack

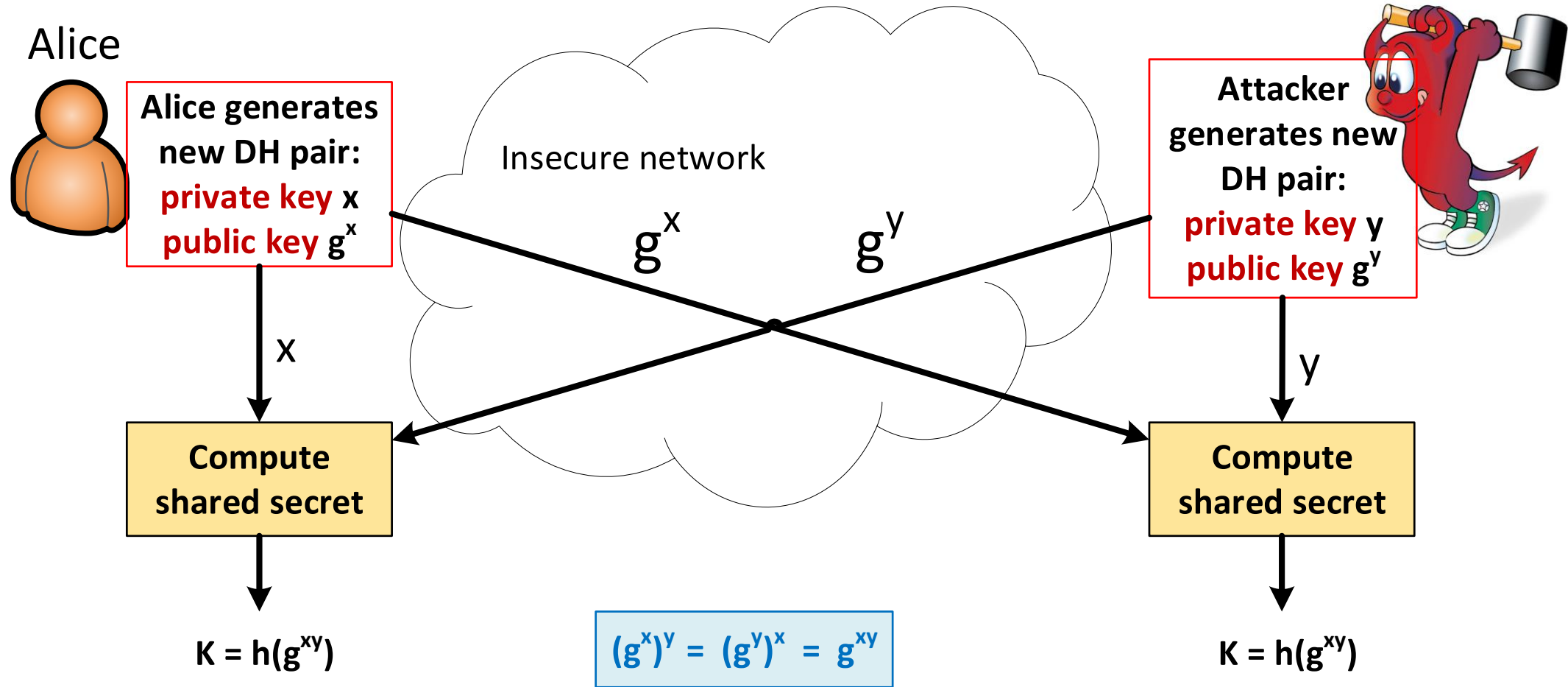

Authenticated Diffie-Hellman

- Diffie-Hellman key exchange is vulnerable to **impersonation attacks**: Shared secret key, ok, but with whom?
Without authentication, it could be anyone.
- Unauthenticated DH is secure against passive attackers who only listen, but not against **active attackers** who also lie and pretend
- Solution: authenticate the key-exchange messages
 - Sign with public-key signatures
 - Compare manually between endpoints

SUMMARY

How strong is cryptography?

- Cryptology viewpoint: requires continuous analysis and improvement
- Engineering viewpoint: **unbreakable for years if you use strong standard algorithms and 128..256-bit symmetric keys**
 - May need to upgrade algorithms every 10 years or so
 - Avoid using algorithms in creative ways that are not their original purpose
- **Weak crypto is worse than no crypto**, use strong algorithms and keys
- Which algorithms can be trusted?
 - Block ciphers have endured relatively well, hash functions require upgrading
 - Quantum computers might break public-key cryptography
- **Almost no absolute proofs of security exist!**

Security vs. cryptography

- Cryptography: mathematical methods for encryption and authentication
- In this course, we use cryptography as **one building block** for security mechanisms
- Remember that cryptography alone does not solve all security problems:

“Whoever thinks his problem can be solved using cryptography, doesn’t understand the problem and doesn’t understand cryptography.”

— attributed to Roger Needham and Butler Lampson

Message size overhead

- Authentication increases the message size:
 - MAC or signature is appended to the message
 - MAC takes 16–32 bytes
 - 4096-bit RSA signature is 512 bytes
 - Elliptic-curve signatures (ECDSA) can be 64..128 bytes
- Encryption increases the message size:
 - In block ciphers, messages are padded to nearest full block
 - IV for block cipher takes 8–16 bytes
 - 1024-bit RSA encryption of the session key is 128 bytes
- Overhead of headers, type tags etc.
- Small size increase ok for most applications but can cause problems in some:
 - Signing individual IP packets (1500-byte limit on packet size)
 - Authenticating small wireless frames
 - Encrypting file system sector by sector, but cannot increase sector size by a few bytes to fit in the IV or MAC

List of key concepts

- Cryptographic hash function, pseudorandom, preimage resistance, second-preimage resistance, collision resistance, birthday attack, MAC, HMAC
- Symmetric cryptography, shared secret key, key length, encryption, decrypting, plaintext, ciphertext, Kerckhoff's principle, block cipher, cipher mode, AES, CBC mode, authenticated encryption, AES-GCM
- Asymmetric or public-key cryptography, key pair, public key, private key, RSA, elliptic-curve cryptography ECC, hybrid encryption, digital signature, key distribution, Diffie-Hellman key exchange, ECDH
- Message secrecy or confidentiality, integrity, authentication, weak and strong cryptography, impersonation

Notations in protocol specifications and research papers

Extra
material

- Shared key:
 $K = SK = K_{AB}$
- Symmetric encryption:
 $Enc_K(M), E_K(M), E(K;M), \{M\}_K, K\{M\}$
- Hash function:
 $h(M), H(M), \text{hash}(M), \text{SHA-256}(M)$
- Message authentication code:
 $MAC_K(M), MAC(K;M), HMAC_K(M)$
- Public/private key:
 $PK = PK_A = K_A = K^+ = K^+_A = e; SK = PK^{-1} = PK^{-1}_A = K^- = K^-_A = d$
- Public-key encryption:
 $Enc_B(M), E_B(M), PK\{M\}, \{M\}_{PK}$
- Signature notations:
 $S_A(M) = \text{Sign}_A(M) = S(PK^{-1}; M) = PK^-_A(M) = \{M\}_{PK^{-1}}$

Reading material

- Stallings: Computer Security Principles and Practice, 4th ed., chapters 2,20,21
- Ross Anderson: Security Engineering, 2nd ed., chapter 5

Exercises

- Confidentiality, integrity, availability – which can be protected with cryptography?
- What kind of cryptography would you use to
 - protect files stored on disk
 - store client passwords on server disk
 - implement secure boot
 - protect email in transit
 - publish an electronic book
 - implement an electronic bus ticket
 - identify friendly and enemy aircraft (“friend or foe”)
 - sign an electronic contract
 - transmit satellite TV
 - protect software updates
 - create a cryptocurrency
 - send pseudonymous letters
 - timestamp an invention
- Which applications require strong collision resistance of hash functions? What attacks have resulted from collisions in MD5?
- Find out about DES cracking; why is DES vulnerable and how much security would it give today?
- What ethical issues are there related to cryptography? Should commercial products use cryptography that is so strong that even the police cannot break it?
- How are quantum computers expected to affect the security of different encryption and authentication algorithms?