



Aalto University
School of Chemical
Technology

Hemicellulose: structure, characterization, dissolution

CHEM-E2140

Cellulose-based fibres

Eero Kontturi

19th September 2023

Assignment

Learning objectives

After this lecture you will be able to:

- Identify a hemicellulose
- Distinguish the main hemicellulose types from each other
- Tell which hemicellulose is typical to a certain plant or plant species
- Gain knowledge on the main properties of hemicellulose

Outline

- (1) Definition of hemicellulose
- (2) Types and structures of different hemicelluloses:
 - Xylan
 - Mannan
 - Xyloglucan
- (3) Occurrence and function of hemicelluloses
- (4) Characterization of hemicelluloses
- (5) Dissolution of different hemicelluloses
- (6) Solution properties

Definition of hemicellulose

- A broad, inexplicit definition of hemicellulose (half-cellulose) refers to plant polysaccharides that are not cellulose
- They are all short chain polysaccharides (DP of ~50-200)
- The term hemicellulose was introduced long before the structures were properly understood
→ A lot of controversy on the real meaning of the term

Most widely accepted explicit definition:

Hemicelluloses are characterized as a group of cell wall polysaccharides that are neither cellulose nor pectin and have a β -(1→4)-linked backbones of glucose, mannose or xylose linked in equatorial configuration.

Definition of hemicellulose

Repeating disaccharide units of hemicellulose

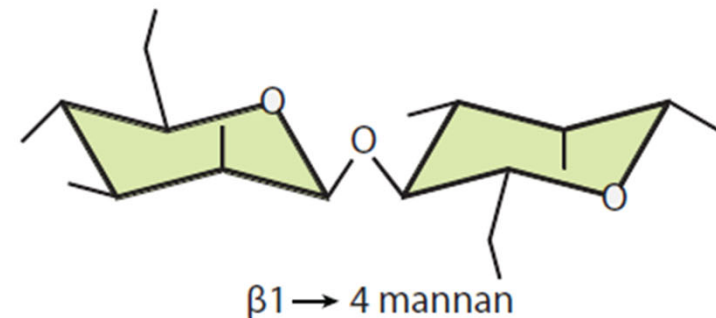
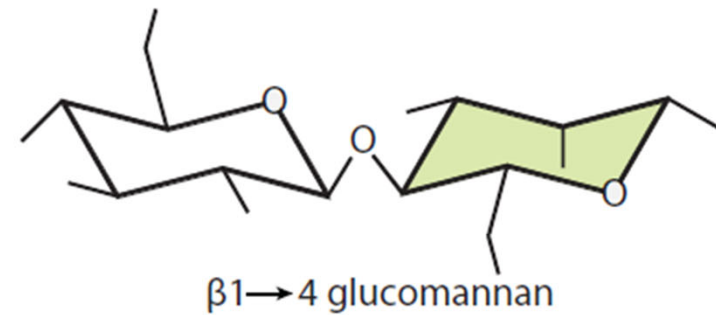
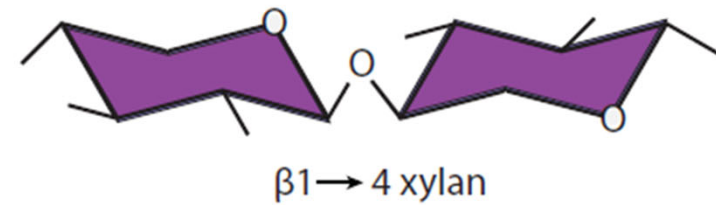
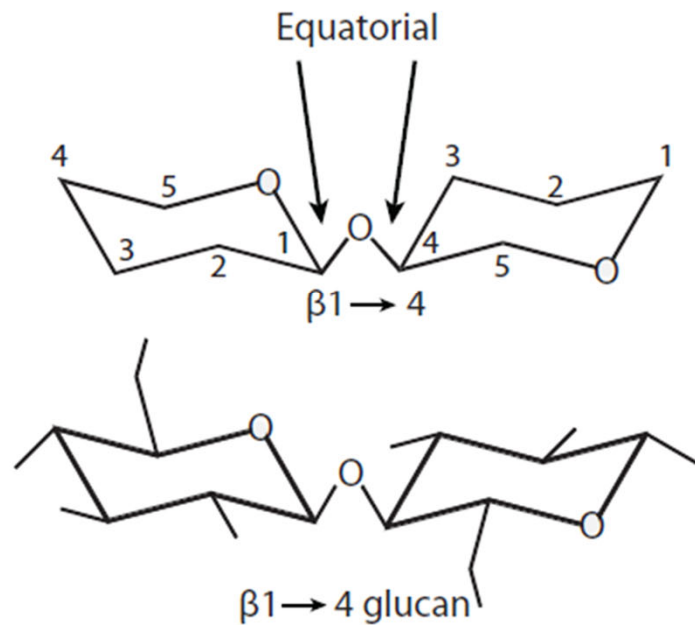

Definition of hemicellulose

Repeating disaccharide units of hemicellulose

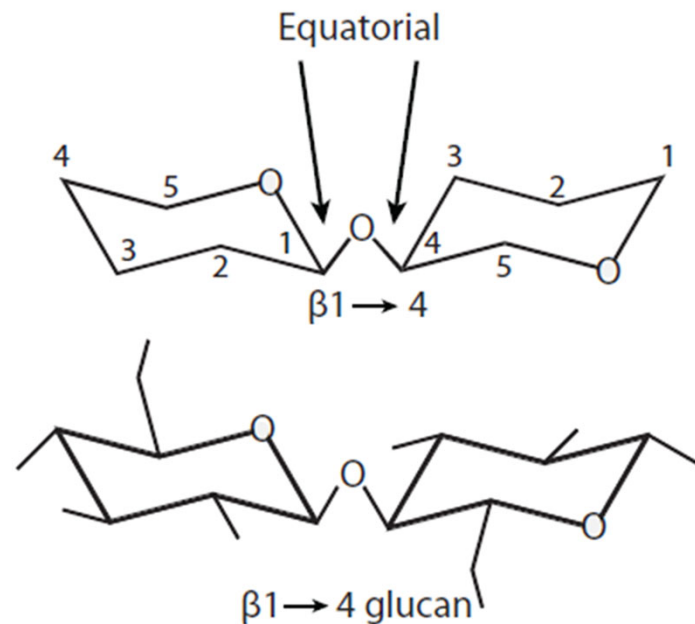

NOTE: Pectin with β -(1 \rightarrow 4)-linked galactan with axial configuration at C4 is not included with hemicelluloses

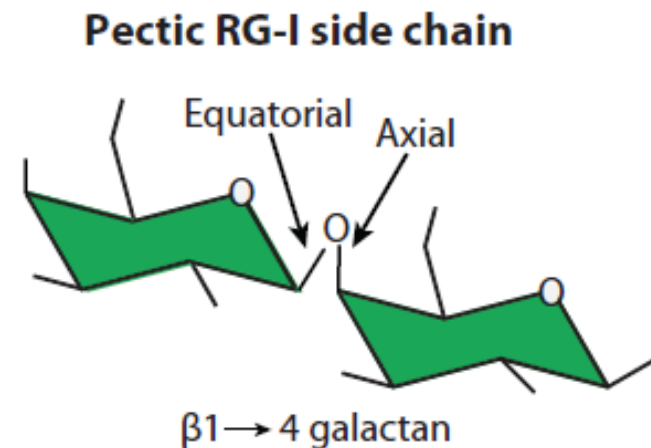

- Also glucans with β -(1 \rightarrow 3)-linked backbone (e.g., callose) are not included

Presemo query

presemo.aalto.fi/e2140hemicellulose

Xylan

General issues on xylans

- Found in most plant cell walls (both terrestrial and algae): sometimes termed the second most abundant biopolymer
- Backbone consists exclusively of xylose
- Often partially acetylated

Xylan structures: glucuronoxylan

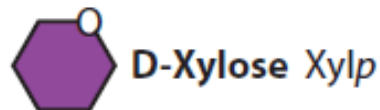
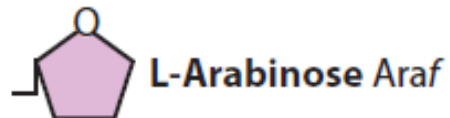
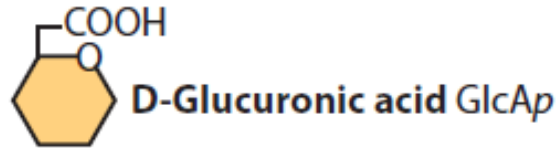

- The most common hemicellulose in the secondary walls of hardwoods
- Backbone consists exclusively of xylose

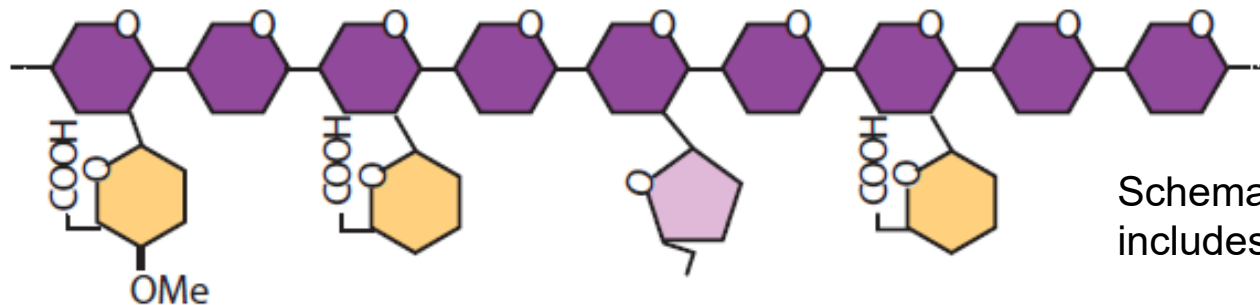

Schematic structure that includes also arabinose

Xylan structures: glucuronoxylan

- Distinguishing side group: **2-linked 4-methyl glucuronic acid unit**
- Xylose : glucuronic acid ratios range from 4-16:1 in hardwoods

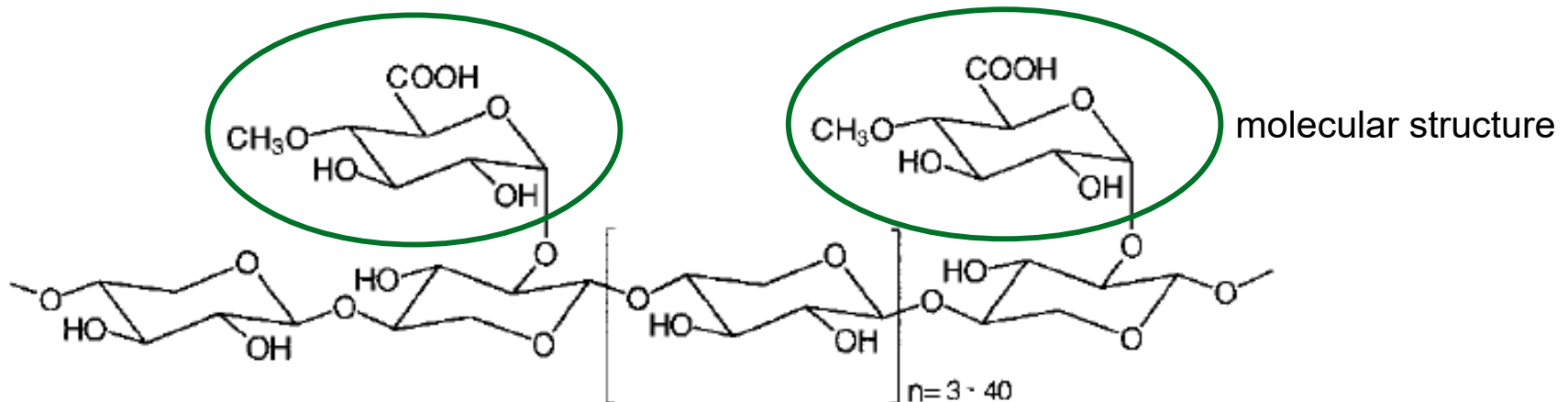

Xylan structures: arabinoglucoronoxylan

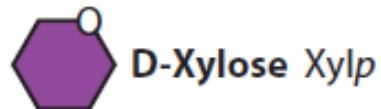
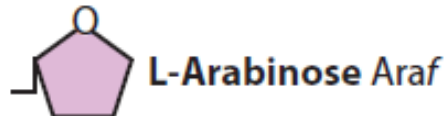
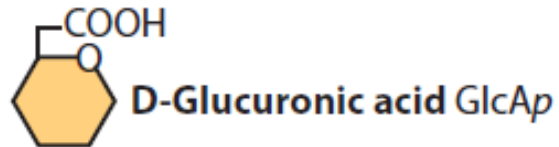

- Second most common hemicellulose in the secondary walls of softwoods
- Typical for the lignified tissues of grasses and annual plants

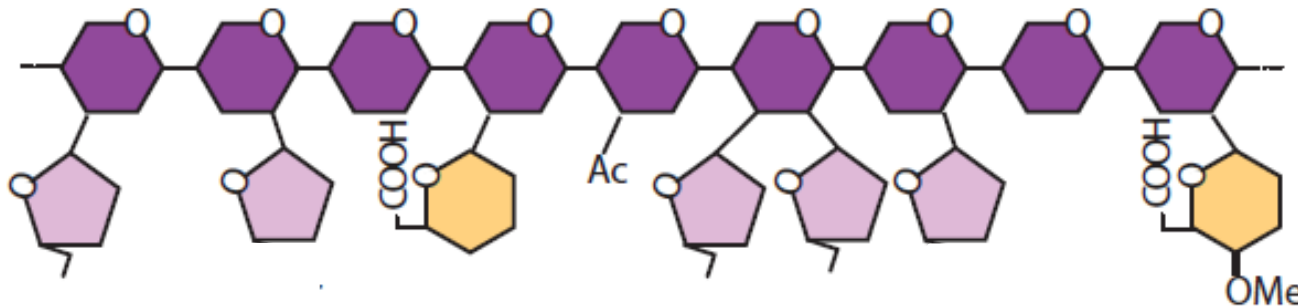

Schematic structure

Xylan structures: arabinoglucoronoxylan

Distinguishing side groups:

- 2-linked 4-methyl α -D-glucuronic acid unit
- 3-linked α -L-arabinofuranosyl (arabinose)

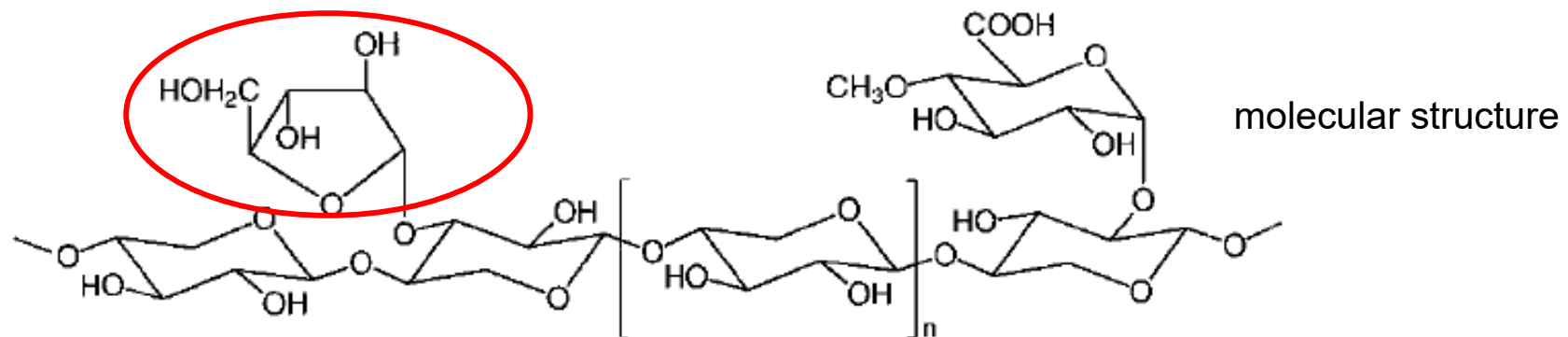

Xylan structures: arabinoglucoronoxylan

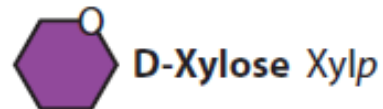
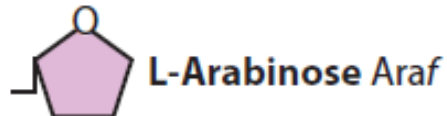
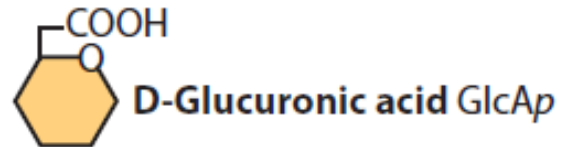

- In *grass xylan*, ferulic acid esters are linked to O5 position of some of the arabinose residues
- Ferulate esters enable cross-linking and enhance cell wall recalcitrance against enzymatic attack

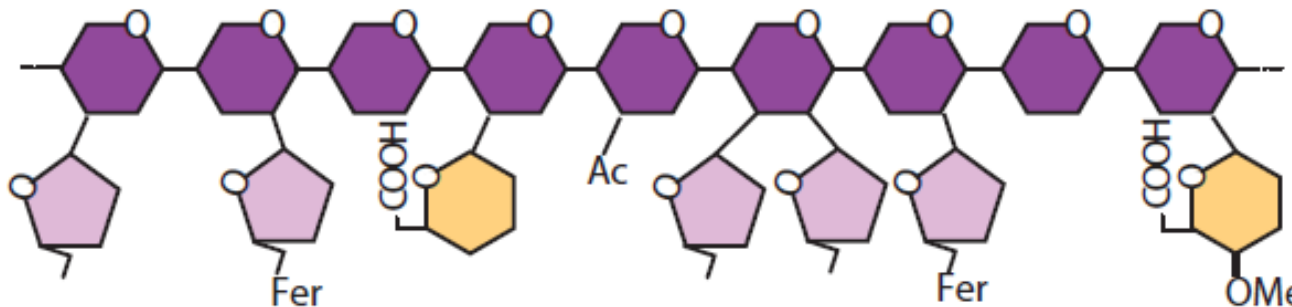
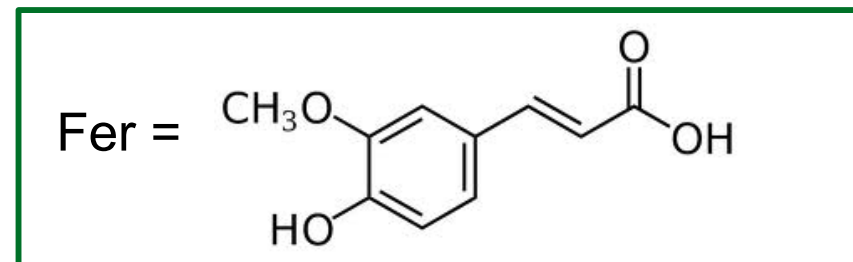

Xylan structures: arabinoxylan

- Uncharged xylan (without the methyl glucuronic acid side group)
- Common in cereal grains
- Distinguishing side group: **2- and/or 3-linked arabinose**

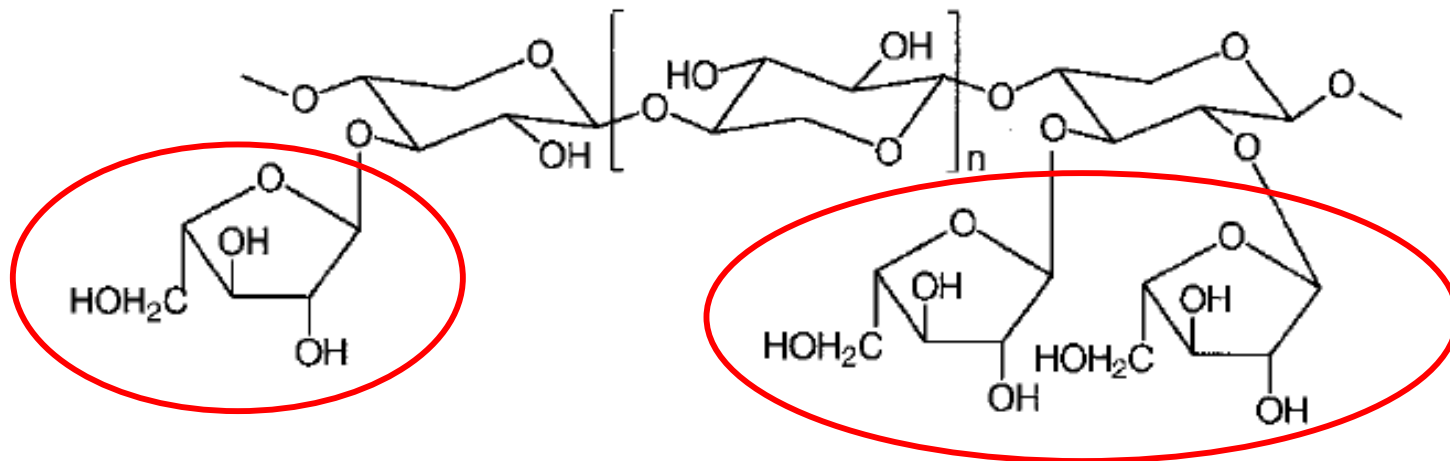

Evolutionary path of xylan

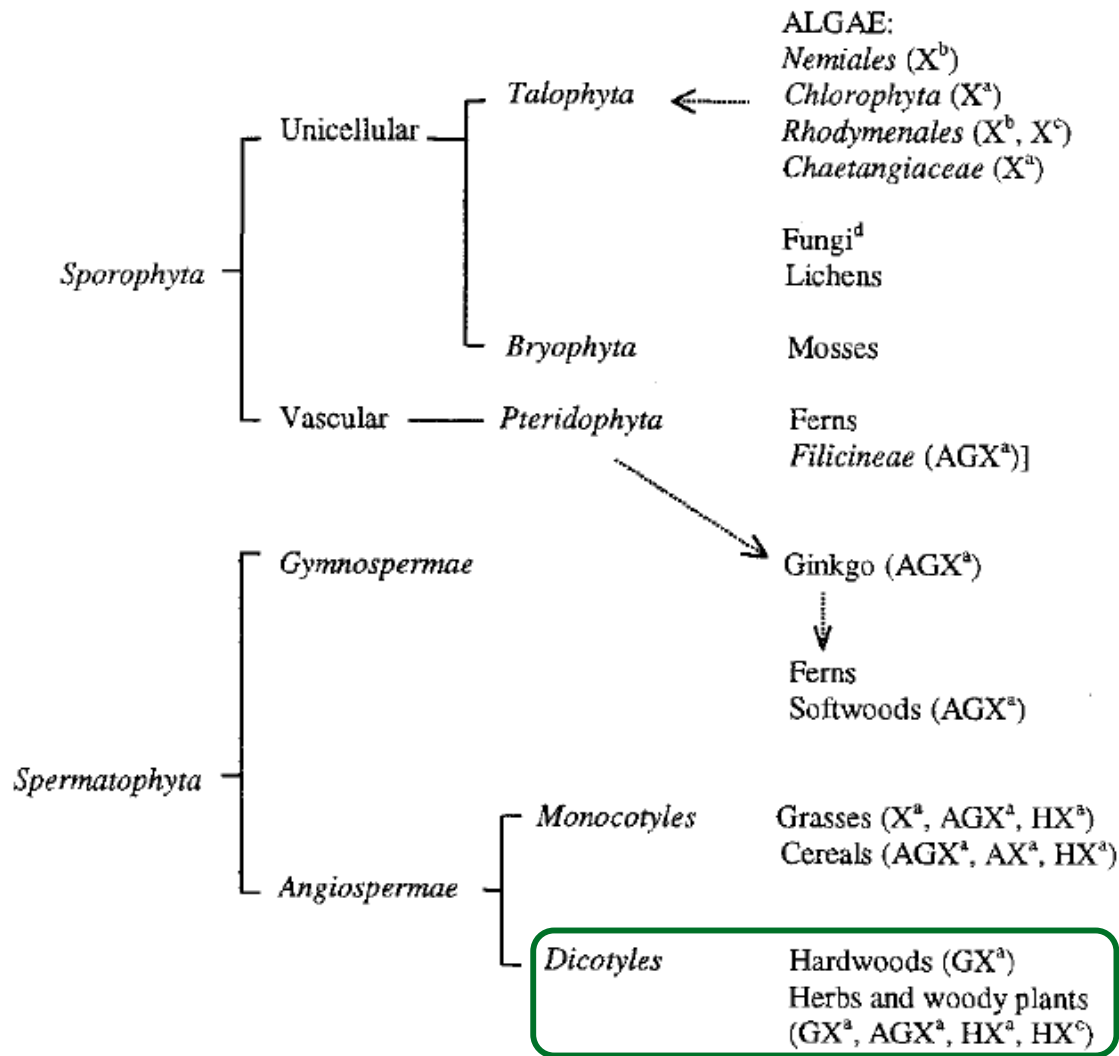

- Arrows indicate the direction of evolution

X – straight chain xylan
 GX – glucuronoxylan
 AGX – arabinoglucuronoxylan
 HX – heteroxylan

The most developed species

Presemo query

presemo.aalto.fi/e2140hemicellulose

Mannan

General issues on mannans

- Found in nearly all plant cell walls
- Backbone may consist exclusively of mannan or of mannose and glucose in a nonrepeating pattern
- Often partially acetylated

General issues on mannans

- Mannans have been highly abundant in early land plants
- They are still abundant in mosses and lycophytes

Lycophytes



Mosses



General issues on mannans

- In conifers, galactoglucomannan is the major hemicellulose
- In hardwood, glucomannans are much less abundant



Structure of galactoglucomannan



- The most common hemicellulose in the secondary walls of softwoods
- Mannose : glucose : galactose ratio in softwoods is 3.5-4.5 : 1 : 0.5-1.1

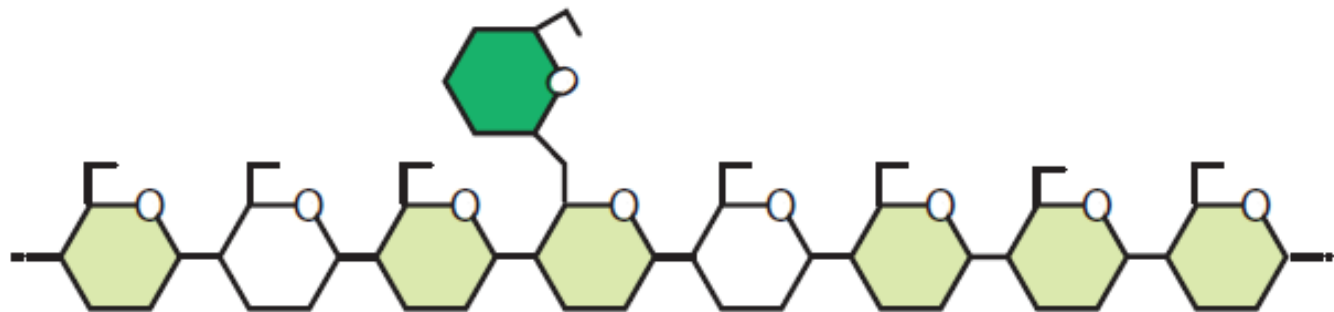

Schematic structure

Structure of galactomannan



- Present in, e.g., Fabaceae seeds and some gums
- Exclusive mannose backbone

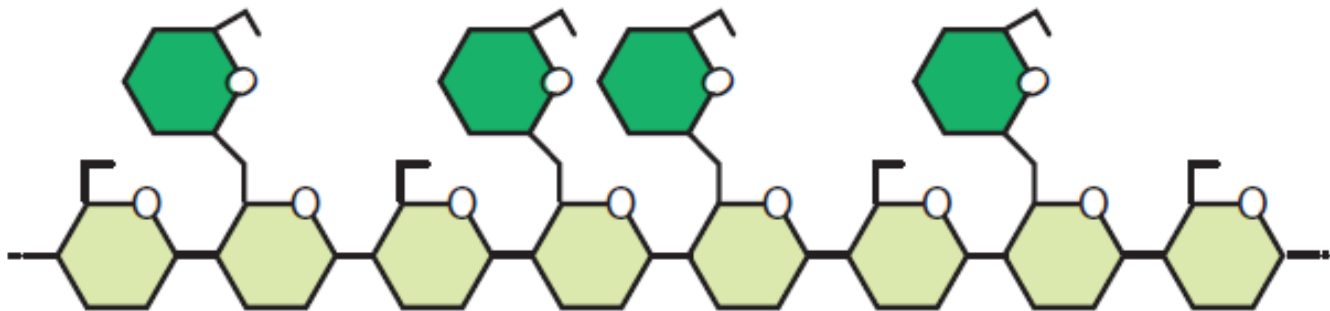

Schematic structure

Various mannan structures (I)

(a) Ivory nut mannan

Pure mannan

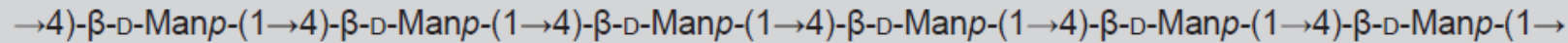

(b) Tara gum (galactomannan)

Without glucose

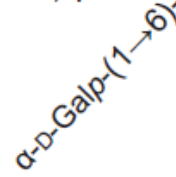
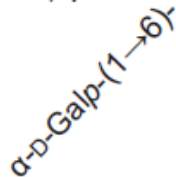
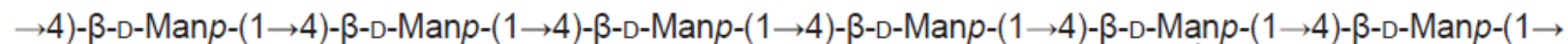

(c) Konjac gum (glucomannan)

Without galactose, occurs in secondary walls of hardwoods

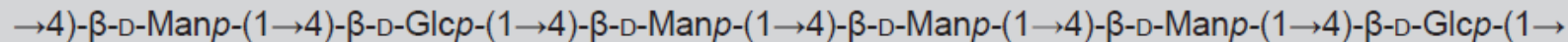

Various mannan structures (II)

Typical softwood galactoglucomannan structures

Acetylated: water-soluble

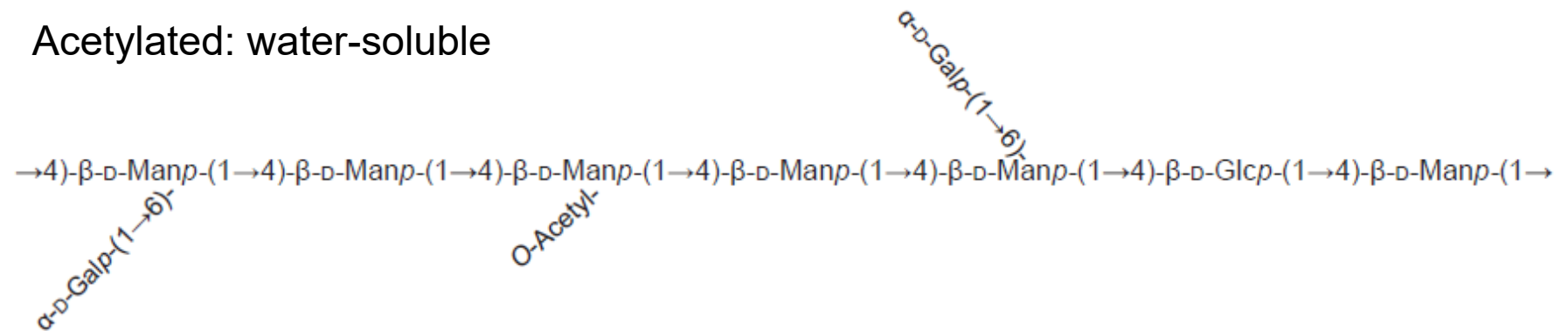

Non-acetylated: insoluble in water

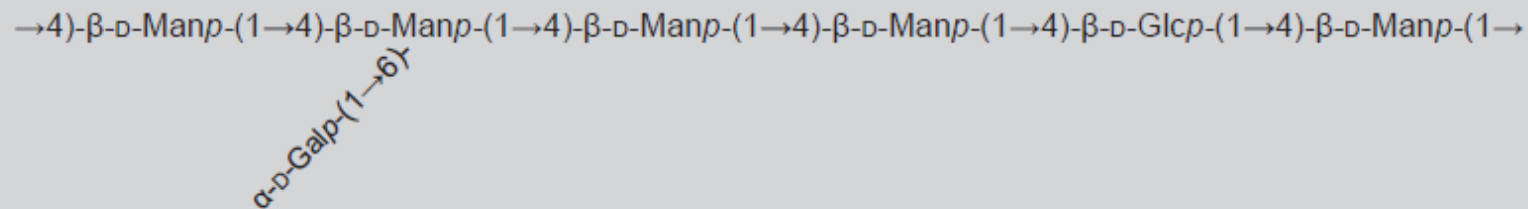

Presemo query

presemo.aalto.fi/e2140hemicellulose

Xyloglucan

General issues on xyloglucans

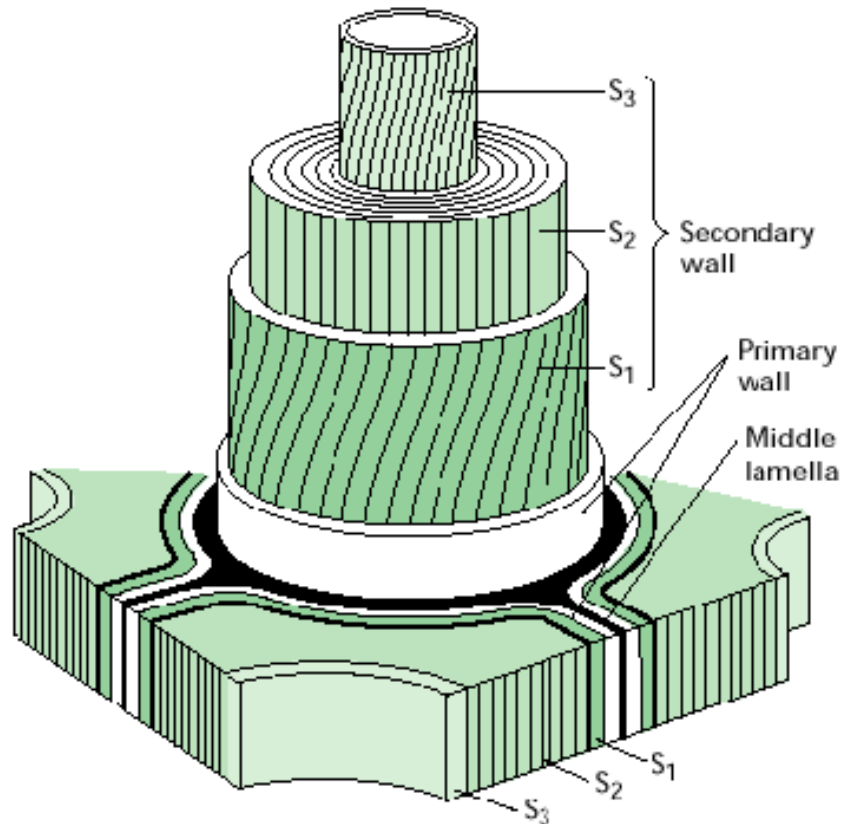

- Xyloglucans are present in the *primary walls* of all land plants
- Xyloglucans are scarcely present in secondary walls

NOTE: Many plants do not possess a secondary wall.

Wood cells possess a very thick secondary wall.

General issues on xyloglucans

- Backbone consists of glucose with xylose linked to most glucose groups by a 6→1 bond
- Other branching saccharides are galactose and fucose

Structure of xyloglucan

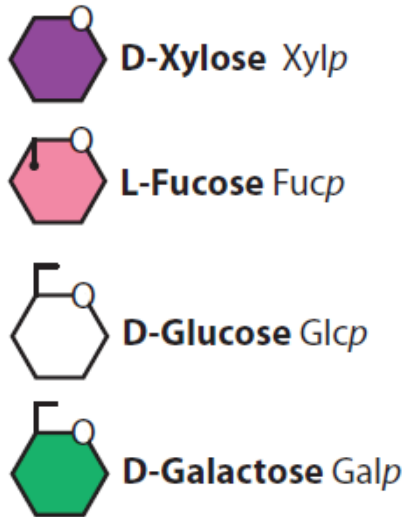

- This structure is typical for the primary wall of eudicotyledons
- It is sometimes referred to as fucogalactoxyloglucan

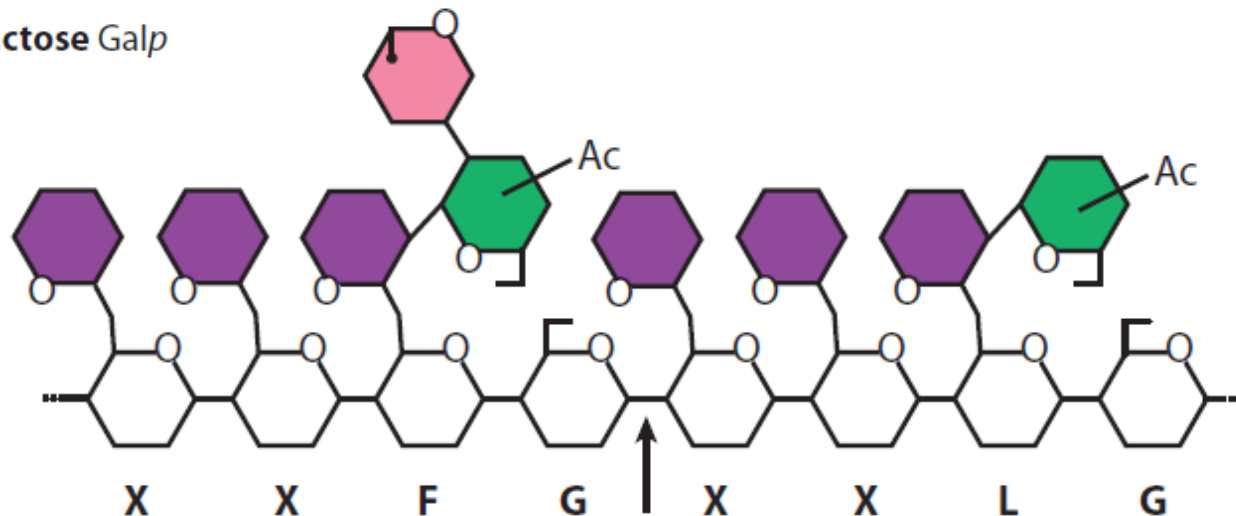

Schematic structure

Xyloglucan nomenclature

- Unambiguous nomenclature exists for xyloglucan oligosaccharides

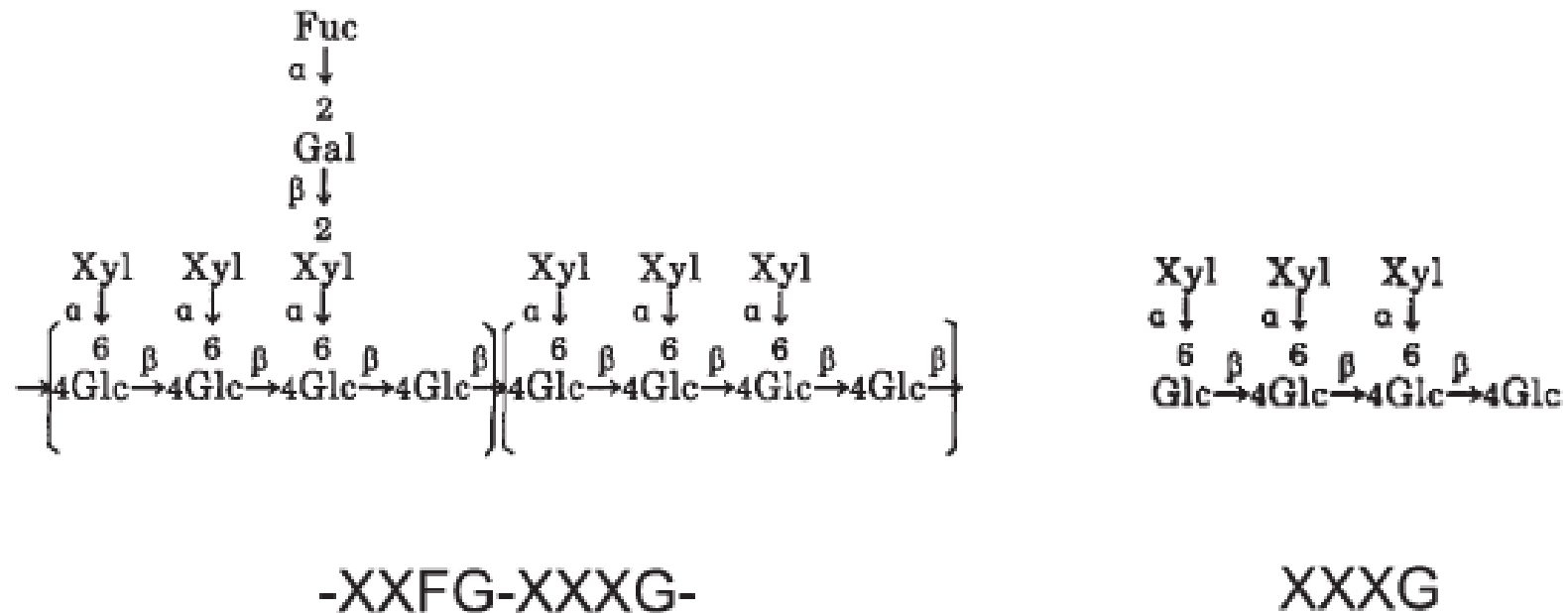

Fry et al. *Physiol. Plant* 1993, 89, 1.

Structure of xyloglucan

A

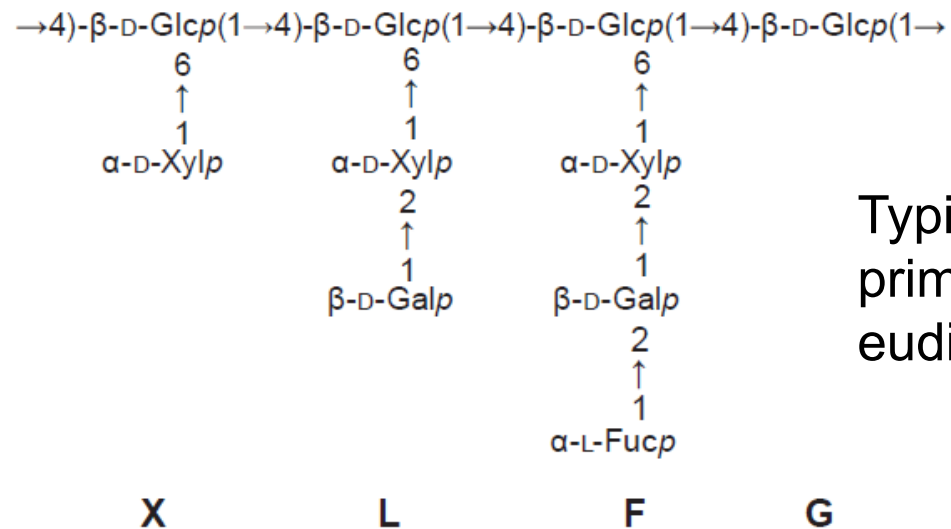

Typical xyloglucan in primary walls of eudicotyledons

B

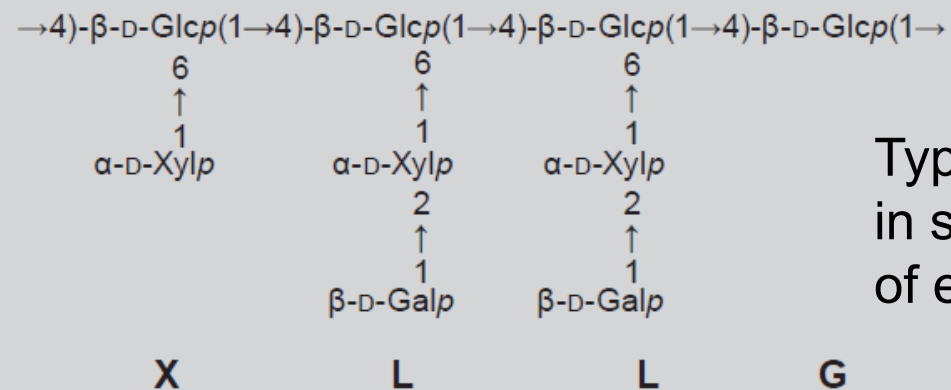

Typical xyloglucan in secondary walls of eudicotyledons

Structure of xyloglucan

A

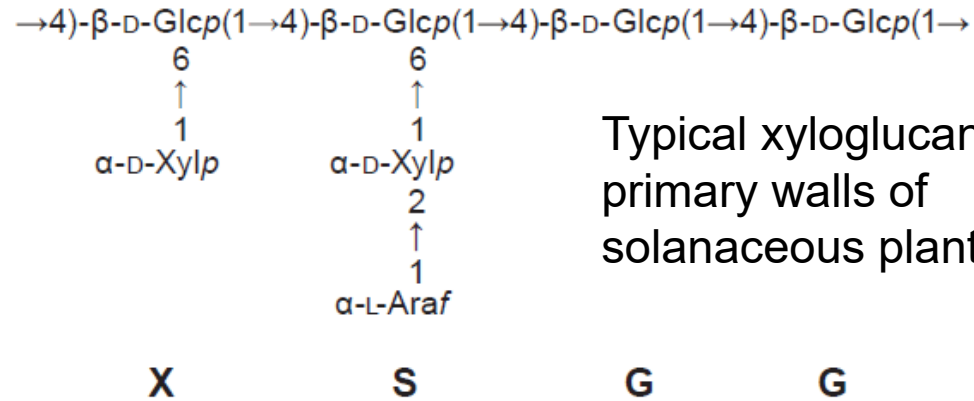

Typical xyloglucan for the primary walls of solanaceous plants

NOTE: no fucose units

B

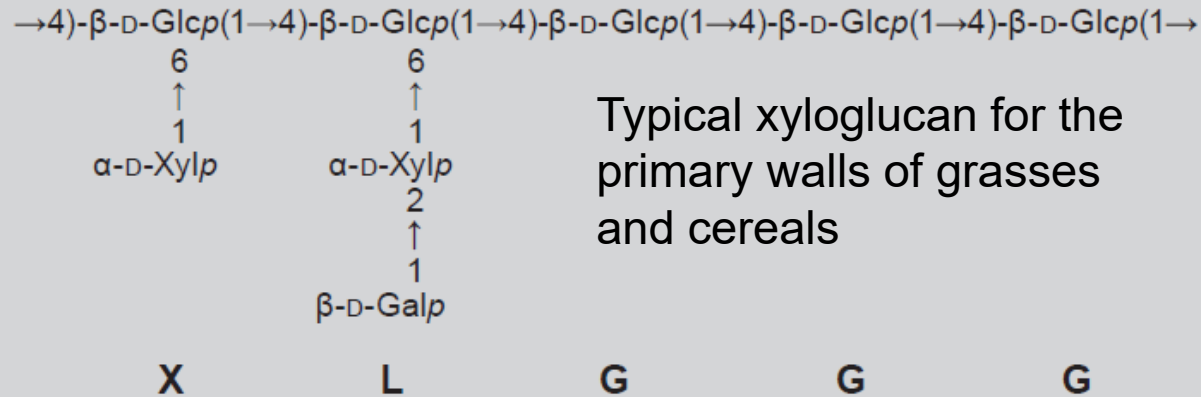

Typical xyloglucan for the primary walls of grasses and cereals

Summary on basic issues

- Hemicelluloses are short chained, polysaccharides made of different monosaccharides, often with side-groups
- Hemicelluloses coexist with cellulose and other polymers in plant cell walls
- Main classes of hemicellulose are xylans, mannans, and xyloglucans

Presemo query

presemo.aalto.fi/e2140hemicellulose

Function and occurrence of hemicellulose

Why does hemicellulose exist?

General explanation:

- The primary role of hemicelluloses is to interact with other polymers to ensure the proper physical properties of the cell wall

NOTE: Hemicelluloses are not indispensable – sometimes the cell wall contains just a few percent of hemicellulose, which is not enough to interact intimately with, e.g., cellulose microfibrils to a significant extent

Hemicellulose in primary wall

- Hemicelluloses are often seen as tethering molecules that cross link cellulose microfibrils

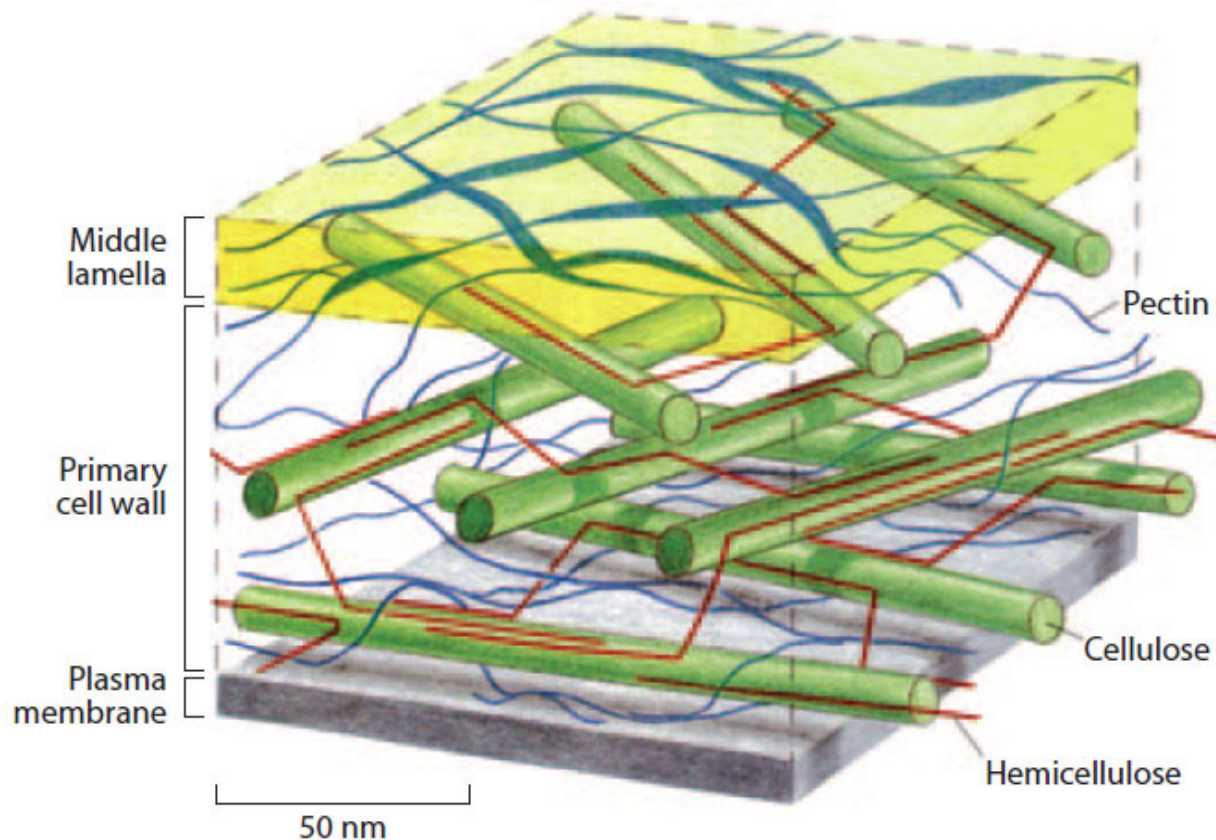

- Xyloglucans are proposed to be intimately hydrogen bonded to cellulose and covalently bonded to pectins
 - Xyloglucans assist cellulose in load bearing
 - Cellulose-xyloglucan network constrains cell enlarging

Biomechanical hotspots in primary wall

New theory:

- Coiled xyloglucan (rather than extended) forms *biomechanical hotspots* in the primary wall, strengthening cellulose microfibril joints

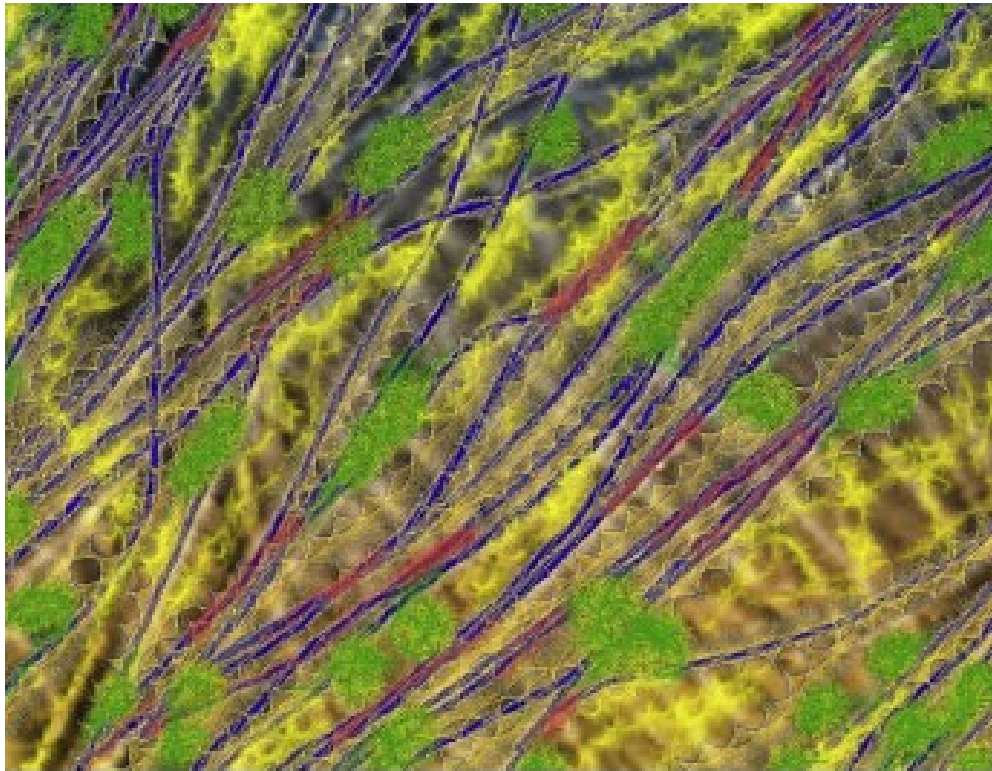

Biomechanical hotspots (red)
Cellulose microfibrils (blue)
Pectins (yellow)
Xyloglucan (green)

- The role of pectin is unclear

Hemicellulose in secondary wall

Proposition for radial cross section

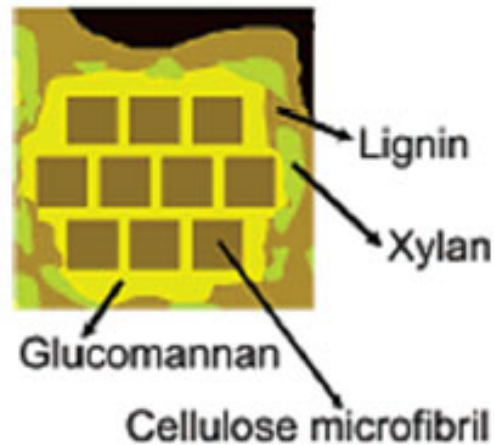

Proposition for longitudinal cross section

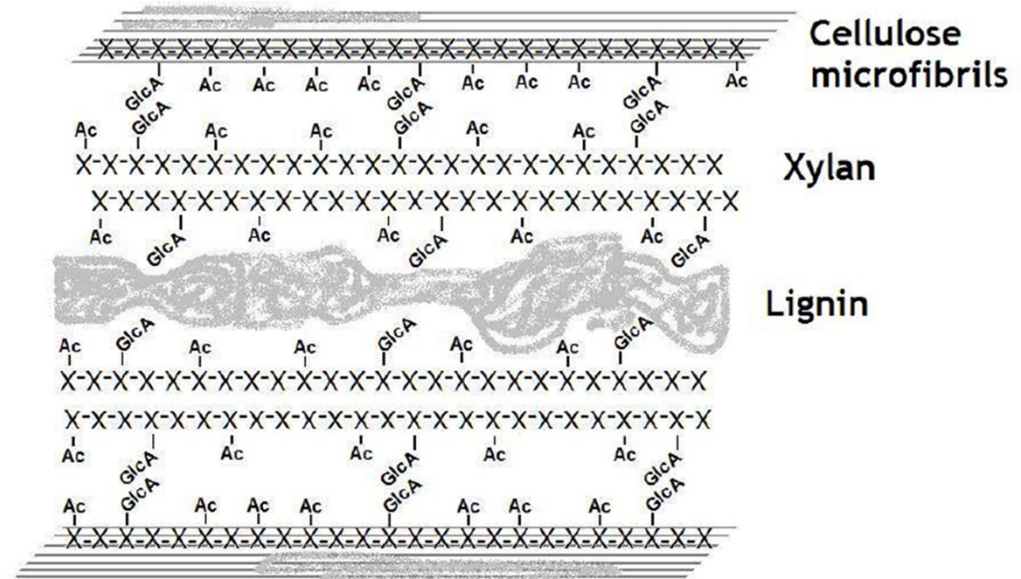

The role and arrangement of hemicellulose in the secondary wall is vaguer than in the primary wall.

New view on secondary wall

Schematics of a cellulose microfibril bundle in softwood secondary wall

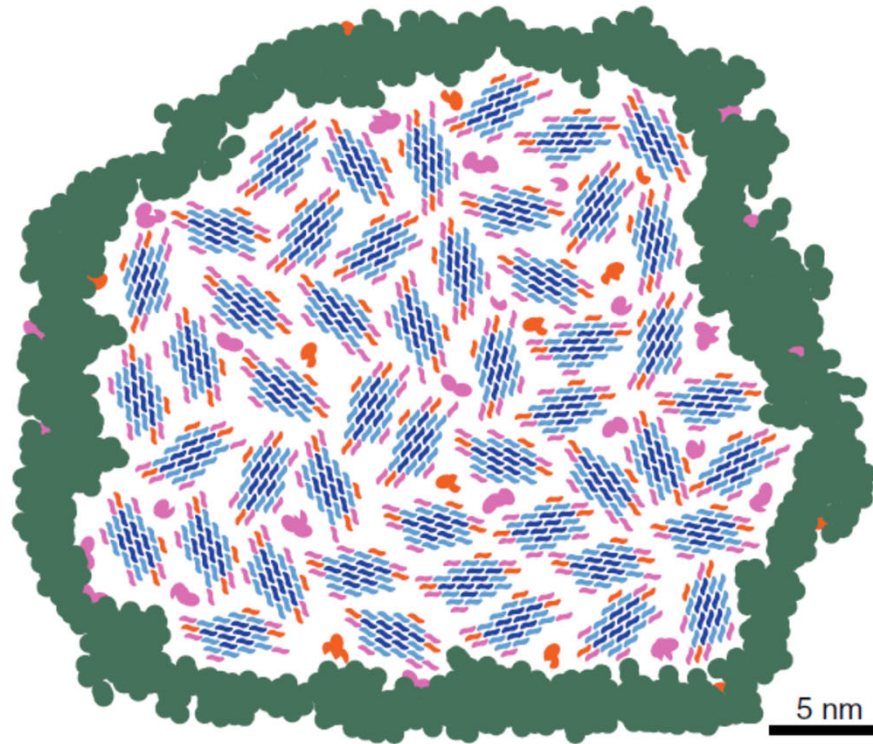

- Galactoglucomannan (GGM) and xylan both highly ordered when bound to cellulose
- Matrix hemicellulose is not as highly ordered
- No lignin inside the microfibril bundle
- Model based on NMR evidence



Cellulose domain 1



Cellulose domain 2



Two-fold xylan



Three-fold xylan



Bound GGM



Matrix GGM



Lignin

Occurrence of hemicellulose

Amount of polysaccharide in wall (% w/w) ^a						
Polysaccharide	Dicot walls		Grass walls		Conifer walls	
	Primary	Secondary	Primary	Secondary	Primary	Secondary
Xyloglucan	20–25	Minor	2–5	Minor	10	– ^b
Glucuronoxylan	–	20–30	–	–	–	–
Glucuronoarabinoxylan	5	–	20–40	40–50	2	5–15
(Gluco)mannan	3–5	2–5	2	0–5	–	–
Galactoglucomannan	–	0–3	–	–	+ ^b	10–30
β-(1→3,1→4)-glucan	Absent	Absent	2–15	Minor	Absent	Absent

Scheller and Ulvskov *Annu. Rev. Plant. Biol.* **2010**, *61*, 263.

Presemo query

presemo.aalto.fi/e2140hemicellulose

Characterization of hemicellulose

Common issues in characterization

- As a rule of thumb, hemicelluloses must be isolated from the plant matrix for reliable characterization
- Destructive characterization: breaking the hemicellulose polymer into monosaccharides and characterization by chromatography
- Non-destructive characterization: spectroscopic techniques

Example of isolation of hemicellulose

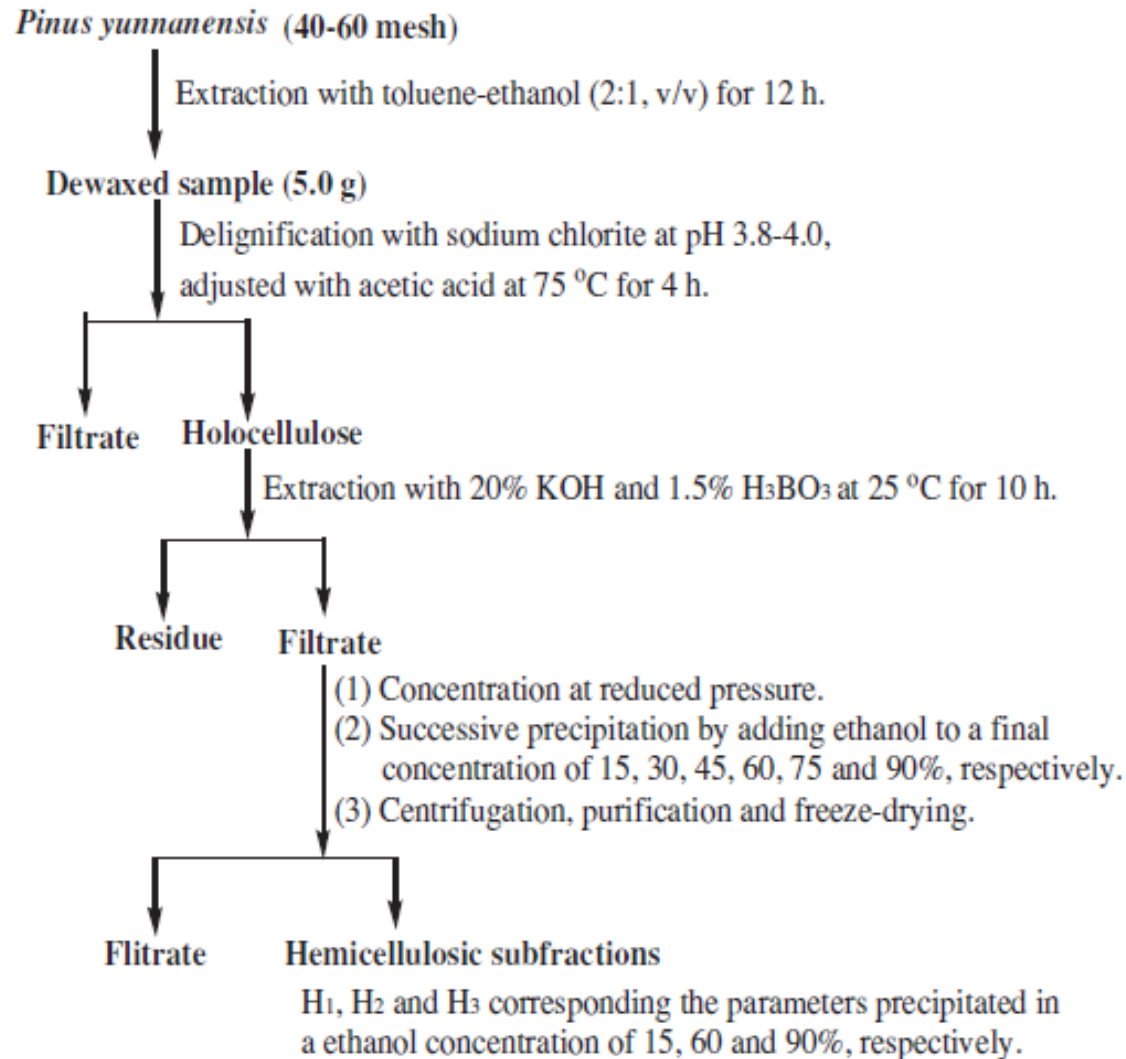

Routine procedure for determination of monosaccharide composition

- 2.5 h hydrolysis in dilute (6%) H_2SO_4
 - Hemicelluloses are degraded to monosaccharides
 - Monosaccharide composition is determined with HPLC

If the amounts of actual hemicelluloses are desired, the results are correlated with the known ratios of monosaccharides for each hemicellulose in the sample from literature.

NOTE: This is the only way to know the exact monosaccharide composition of the plant-based sample.

Infrared spectroscopy

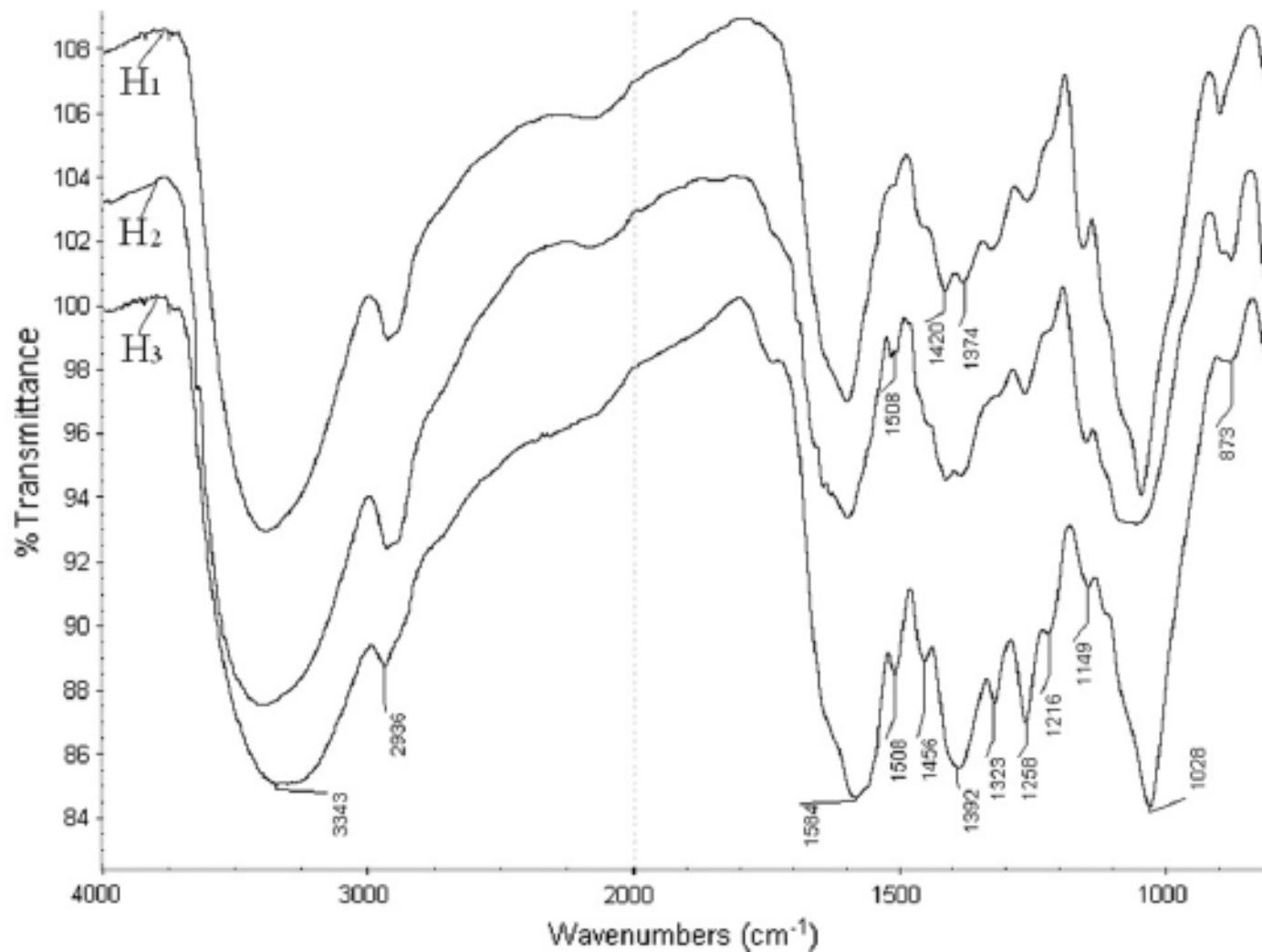

In general, there is too much overlap in the characteristic bands of hemicelluloses to perform reliable IR analysis.

Nuclear magnetic resonance (NMR)

Chemical shifts (ppm) can be explicitly addressed to specific carbons of specific hemicelluloses
→ powerful method

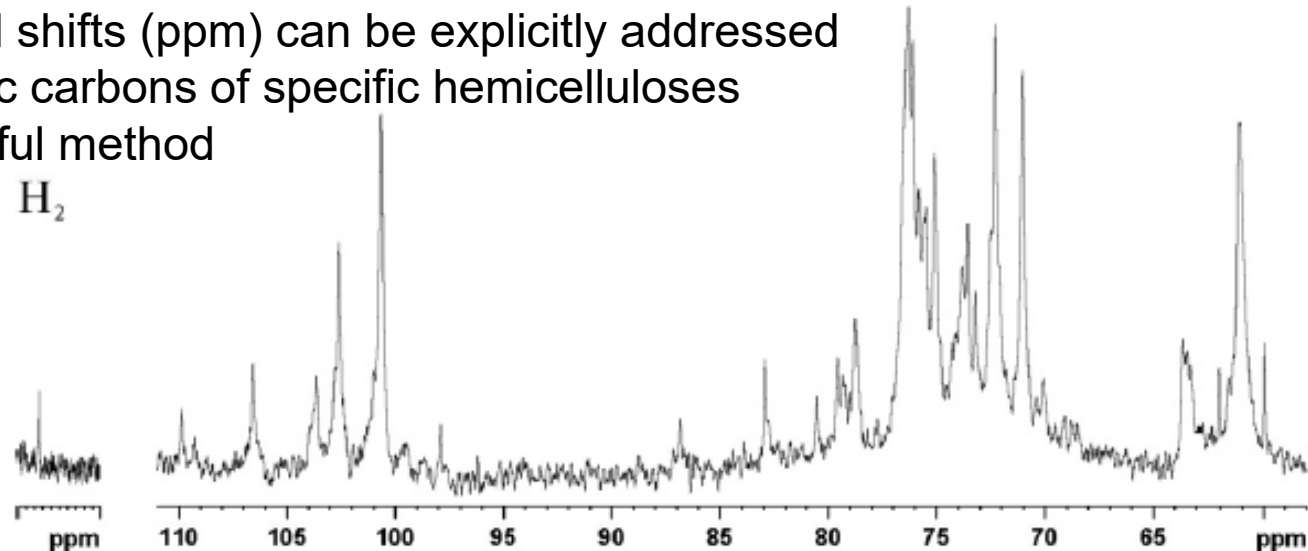

Table 3
¹³C NMR data on the constituent monosaccharide residues in the hemicellulosic fraction H₂ (δ/ppm)

Residue	C-1	C-2	C-3	C-4	C-5	C-6
Gal	106.57(α-) 101.00(β-)	75.0–71.0	75.0–71.0	75.0–71.0	n.d. ^b	63.62
Glc	103.63 (non-red ^a)	73.82	78.76	79.57	75.11	63.62 (non-red)
Man	100.64	70.02	72.30	76.31	75.83	61.16 70.07
Xyl	102.60	n.d.	75.47	75.83	n.d.	n.d.
Ara	109.85	80.52	78.76	86.83	62.04	n.d.
GlcA	97.88	73.20	79.34	82.93	n.d.	177.36

^a Non-red = non-reducing units.

^b n.d. represents not detected.

Xue et al. *Carbohydr. Polym.* **2012**, 352, 159.

Summary on basic issues

- The structures of hemicelluloses depend on the plant or even the cell wall layer in which they were biosynthesized
- In the primary wall, xyloglucan is important in load bearing with cellulose
- In the secondary wall, the role of hemicellulose is not as clear as in the primary walls; they swell extensively in water and therefore they partially control the water content of the cell wall

Presemo query

presemo.aalto.fi/e2140hemicellulose

Dissolution of hemicelluloses

- xylan
- mannan
- xyloglucan

General issues on hemicellulose dissolution

Rules of thumb:

- more branched structures are easier to dissolve
- linkages with lignin reduce solubility
- linkages with cell-wall proteins reduce solubility
- acetylated structures are more water-soluble

NOTE: Many issues on hemicellulose dissolution are unresolved; systematic studies are lacking in most cases.

Dissolution of xylan

- Most xylans bear a polyelectrolyte structure through 4-O-methylglucuronic acid moieties
 - However, the charged groups are generally not enough to solubilize xylan in water
- Partial acetylation of C-2 and C-3 is required

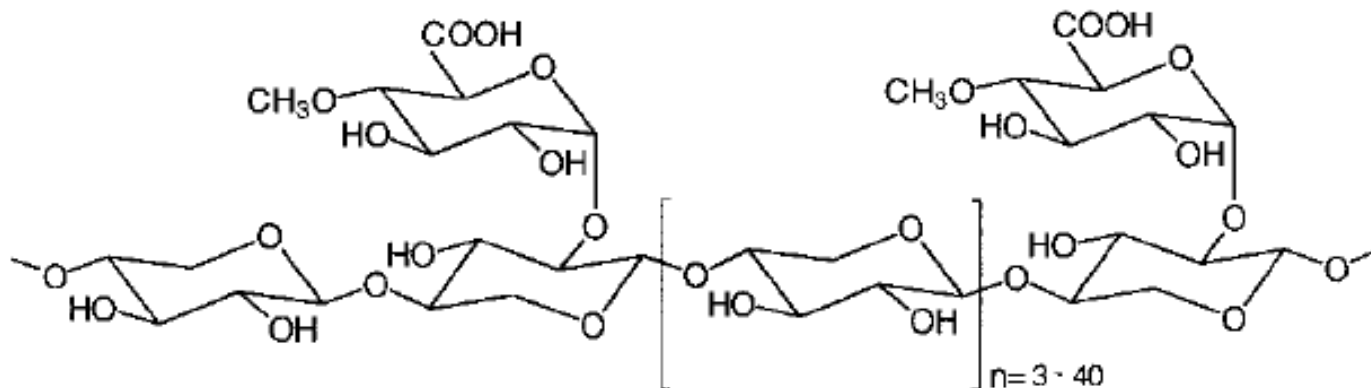

Dissolution of xylan

- Addition of alkali to aqueous solutions increases considerably the solubility of xylan
- When dissolving (isolating) xylan directly from wood cell wall, delignification considerably enhances the xylan yield

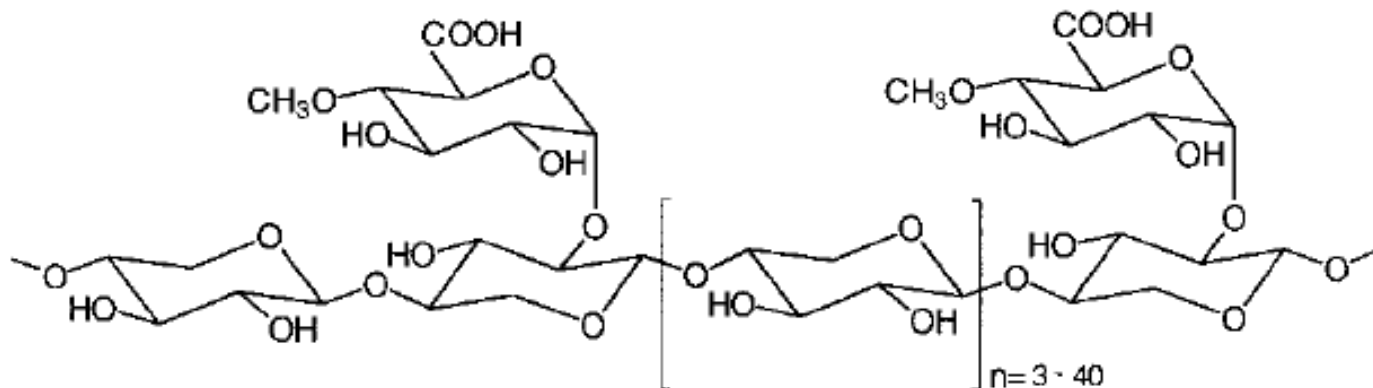

Dissolution of xylan

- Dimethylsulfoxide (DMSO) is able to efficiently dissolve most xylan grades
- Addition of water to DMSO solution enhances the solubility of low-branched xyans

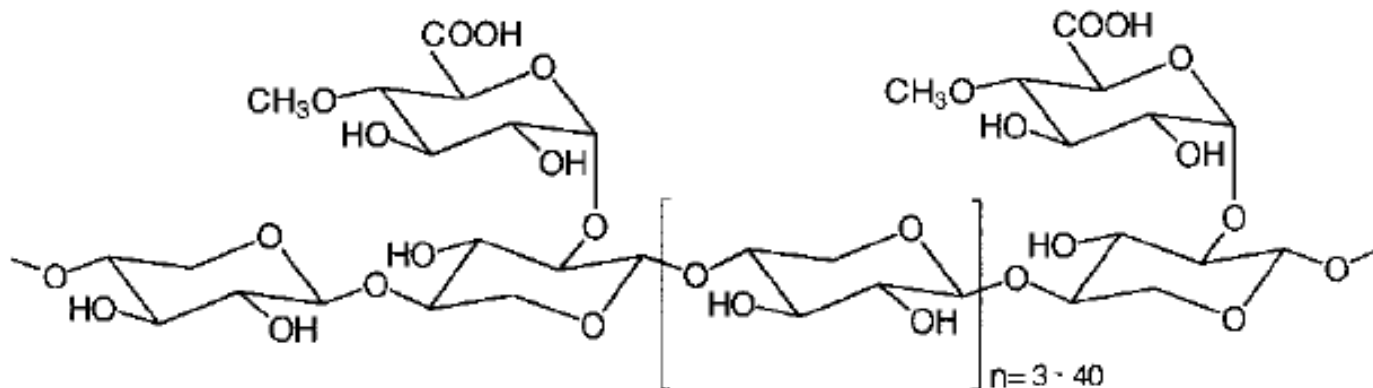

Dissolution of xylan

- When isolating xylan from the cell wall through, e.g., alkaline extraction, some of the xylan remains in the fibre
- Proposition: some of the xylan is intimately entangled with cellulose and therefore cannot be dissolved

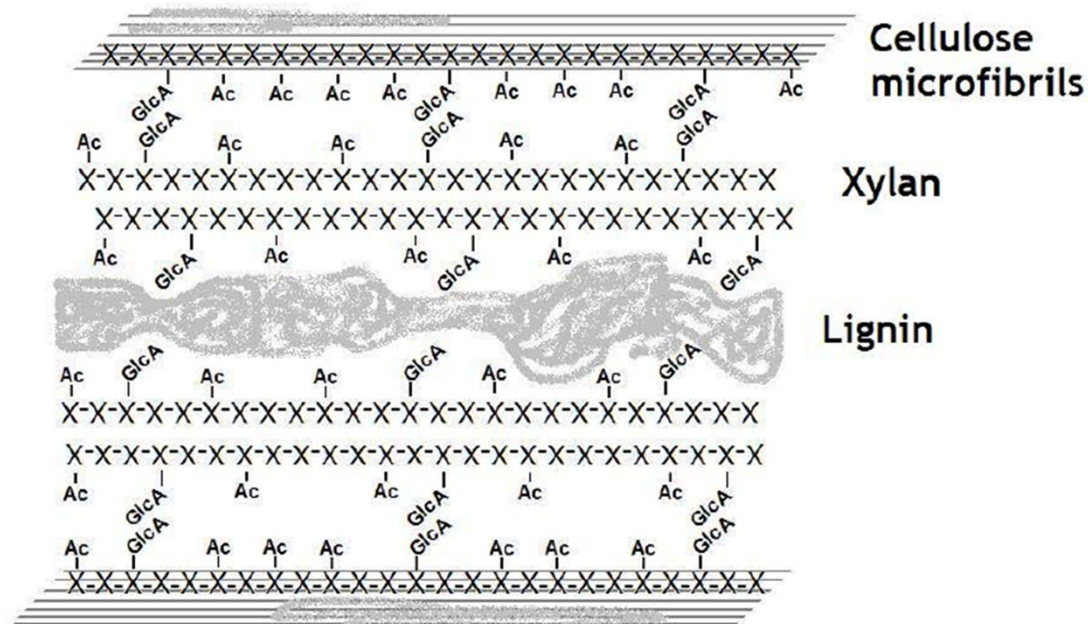

Dissolution of galactoglucomannan

- Native galactoglucomannans from softwoods are partially acetylated at C-2 and C-3 positions ($DS_{Ac}=0.17-0.36$)
- Acetylated galactoglucomannans are soluble in water
- A large share of galactoglucomannans dissolve during chemical and even mechanical pulping

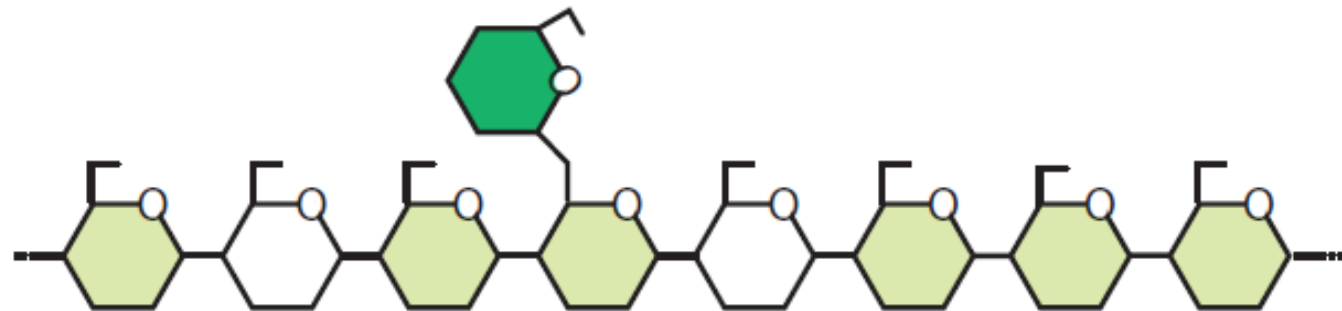

Dissolution of mannans

- Like xylans, most mannan grades (also non-acetylated) can be dissolved in dimethylsulfoxide (DMSO)

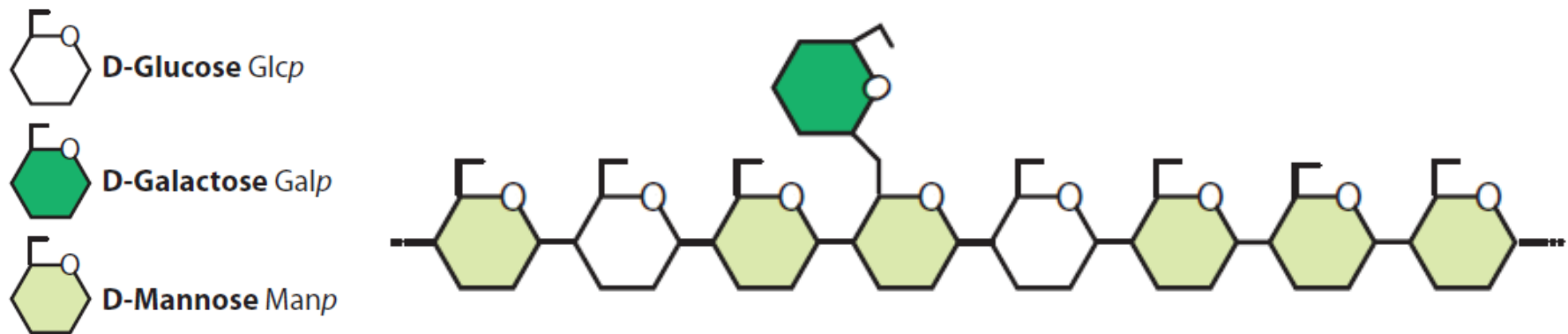

Dissolution of xyloglucans

- xyloglucans generally dissolve in water

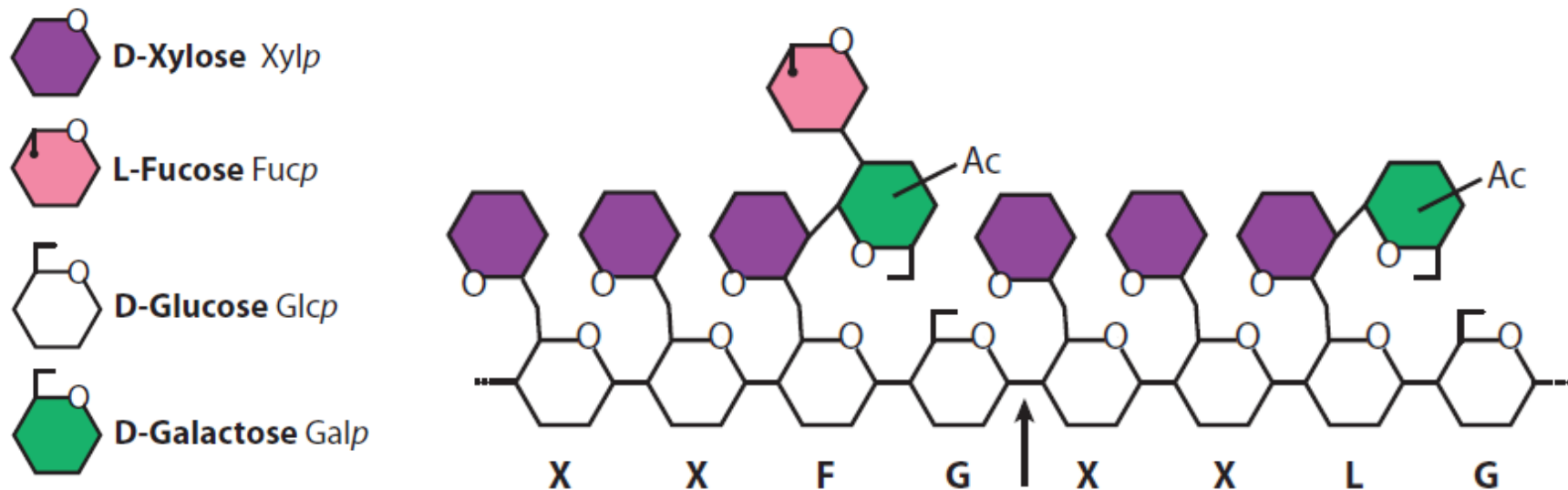

Dissolution – summary

- Aqueous alkali usually dissolves most (acetylated) hemicelluloses
- If hemicellulose is extracted (isolated) with aqueous alkali from the fibre, part of it always remains in the fibre
- DMSO is a good solvent for hemicellulose – also the non-acetylated ones
- Many cellulose solvents dissolve also hemicellulose appreciably (the whole cell wall can dissolve)

Presemo query

presemo.aalto.fi/e2140hemicellulose

Assignment