

AMP320 Product Manual



EFE

16, rue de la Porte à Bateaux- F-27540 Ivry La Bataille, France

Tél. +33.2.32.22.35.03

Fax. +33.2.32.36.93.08

www.efe-sensor.com

infos@efe-sensor.com

Table of Contents

Default Settings	3
Connections	3
Standard Span & Zero Adjustment	4
Shunt Readings	5
Switch Configurations	5
Excitation	6
Polarity	6
Gain	6
Current Setting ⁽⁴⁾	7
Advanced Span and Zero Adjustment	7
Adjusting the Zero	7
Adjusting the Span.....	7
Appendix A (Noise levels).....	8
Appendix B (Specifications).....	9

Default Settings

- Input Range: 0 to +/-2 mV/V
- Excitation Voltage: 10 VDC
- Output Range: +/-10 VDC, 4-20 mA

Input Connection

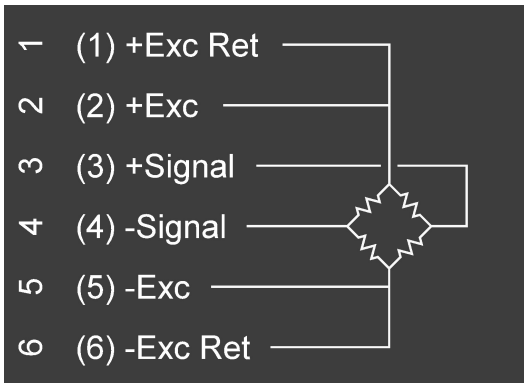

Pin	Wiring Code
1	+Excitation Return (1)
2	+Excitation
3	+Signal
4	-Signal
5	-Excitation
6	-Excitation Return (1)

Output Connection



Pin	Wiring Code
1	Power Supply
2	Signal Output (Voltage)
3	Reference (0V)
4	Signal Output (Current)

Note: Do not connect the device to the power supply when the power supply is already on!

(1) For 6 wire sensors connect +Sense to +Excitation Return and -Sense to -Excitation Return

Standard Span & Zero Adjustment

Once all of the connections are complete, you can begin to set up the sensor/amplifier system. You will need to have the output from the AMP320 connected to a device so you can read the voltage or current.

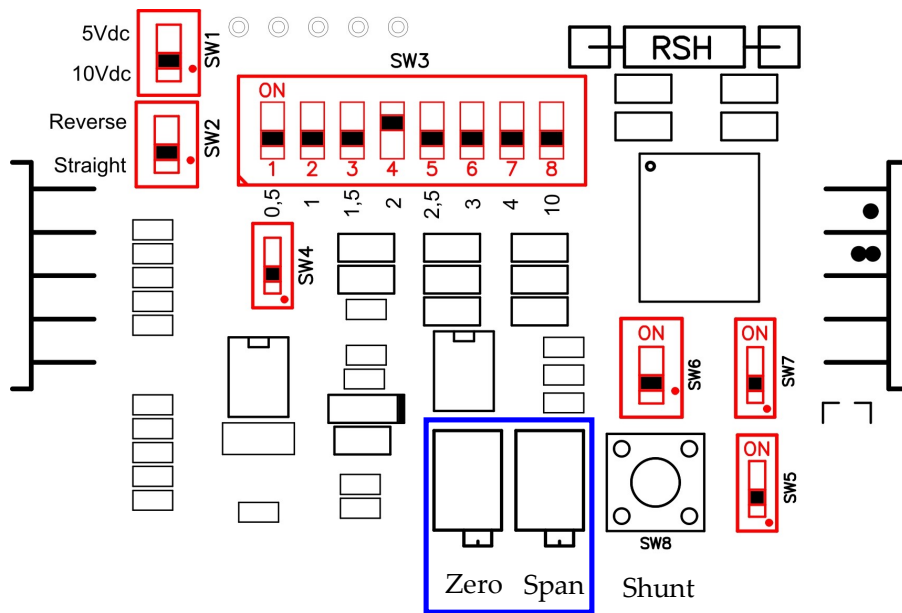

To set up the system, follow the steps below:

1. Apply a known load to the sensor.
2. Allow the sensor to settle.
3. Use a screwdriver to adjust the span that correlates with that load.
4. Remove the load.
5. Allow the sensor to settle.
6. Adjust the zero.

Ex. If you are applying a full load to the sensor with an excitation voltage of 10 VDC, then you would want to adjust the output (span) to 10VDC or 20mA. If you are applying half of the full load then you would want to adjust the span to exactly half of the maximum. Once your span is set, check the zero. With no load applied to the sensor, adjust the zero.

Note : Adjusting the zero and span is done by using a screw driver to adjust the potentiometers.

Shunt Readings

Shunt resistors simulate a load on the load cell; thus, allowing for calibration. Follow the steps below in order to utilize the shunt feature.

1. Determine the value of the shunt resistor needed
2. Connect the shunt resistor in the spot labeled 'RSH'.
3. Press the pushbutton that corresponds to the shunt.
4. While the shunt is enabled and the AMP320 is reading the simulated load, adjust the span (described above) to the correct output.

Ex. If you are using a 2 mV/V sensor with a 350 Ohm bridge and the default 60.4 kOhm resistor on the AMP320, then the simulated load would be approximately 72% of R.O. You can then adjust the span to 7.2 VDC to correlate with this simulated load.

Switch Configurations

To change any of the switch configurations from the default settings, follow the tables below to set your desired configuration. The figure below shows the default configuration.

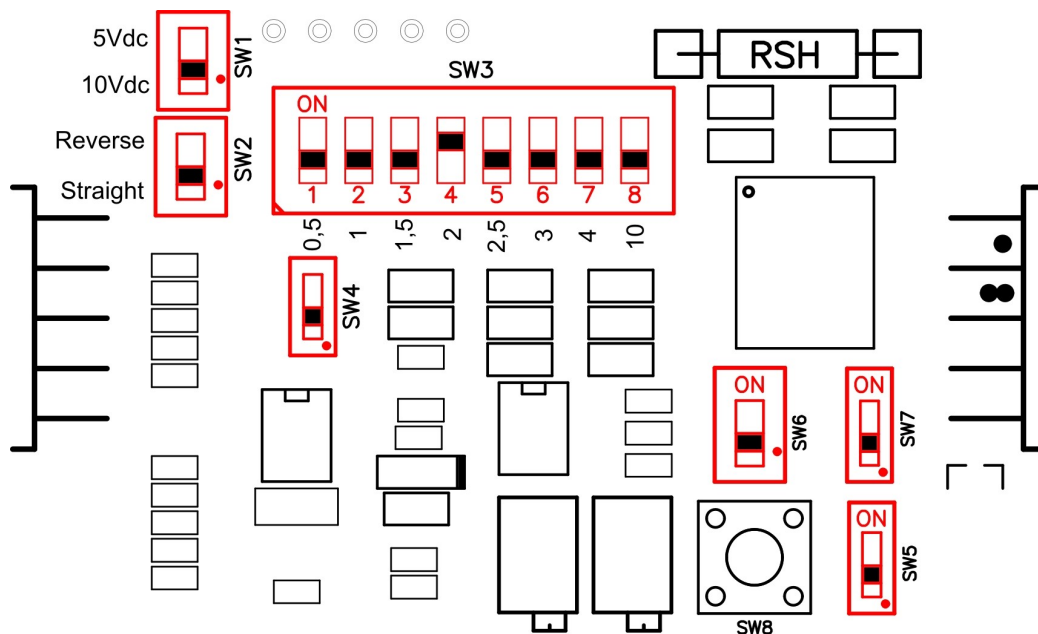

Excitation

There are two excitation values available on the AMP320: 10 VDC (default) and 5 VDC. To select the excitation, simply flip the DIP switch to the appropriate configuration. The excitation voltage controls the maximum output of the amplifier.

Ex. If your application requires a lower output voltage than 10 VDC, then the 5 VDC option is available to use. All you have to do is flip the DIP switch from the down position to the up position.

SW1 - Excitation (Vdc)	
UP	5
DOWN	10

Polarity

There are two polarities available on the AMP320: reverse and straight (default). To select the polarity, simply flip the DIP switch to the appropriate configuration.

Ex. If you are using your AMP320 with a tension and compression load cell and you have tension setup as the positive direction, but now you would like to have compression as the positive direction, all you have to do is flip the DIP switch from the default polarity position to the reverse polarity position.

SW2 - Polarity	
UP	Reverse
DOWN	Straight

Gain

There are eight gain settings available on the AMP320 : from 0.5 mV/V to 10 mV/V. The default setting is configured to 2 mV/V. Select the value closest to your input range by flipping the DIP switches to the appropriate configuration.

Ex. If you are using a 2 mV/V sensor with the 5 VDC excitation, then you would want to use configuration 2 for 1 mV/V. If you are using a 2mV/V sensor with 10 VDC excitation then you would want to use configuration 4 for 2 mV/V.

SW3 - Gain								
	1	2	3	4	5	6	7	8
0.5mV/V	ON	OFF	OFF	OFF	OFF	OFF	OFF	OFF
1mV/V	OFF	ON	OFF	OFF	OFF	OFF	OFF	OFF
1.5mV/V	OFF	OFF	ON	OFF	OFF	OFF	OFF	OFF
2mV/V	OFF	OFF	OFF	ON	OFF	OFF	OFF	OFF
2.5mV/V	OFF	OFF	OFF	OFF	ON	OFF	OFF	OFF
3mV/V	OFF	OFF	OFF	OFF	OFF	ON	OFF	OFF
4mV/V	OFF	OFF	OFF	OFF	OFF	OFF	ON	OFF
10mV/V	OFF	OFF	OFF	OFF	OFF	OFF	OFF	ON

Current Setting

There are four current output settings available on the AMP320 : 0-16 mA, 0-20 mA, 4-20 mA (default), and 5-25 mA. To select the current, simply flip the DIP switches to the appropriate configuration.

SW5	SW6	SW7	Input Range (V)	Output Range (mA)
OFF	OFF	OFF	0-10 VDC	4-20 mA
OFF	OFF	ON	0-10 VDC	5-25 mA
ON	OFF	OFF	0-10 VDC	0-16 mA
ON	OFF	ON	0-10 VDC	0-20 mA
OFF	UP	OFF	0-5 VDC	4-20 mA
OFF	ON	ON	0-5 VDC	5-25 mA
ON	ON	OFF	0-5 VDC	0-16 mA
ON	ON	ON	0-5 VDC	0-20 mA

Note: Only available with current output option.

Advanced Span and Zero Adjustment

Adjusting the Zero

At times, when using a signal conditioner, it is necessary to offset the zero. The AMP320 makes this simple. The zero can be adjusted approximately $\pm 10\%$ of R.O. by using the potentiometer on board.

Adjusting the Span

The input jumpers vary from 0.5 mV/V to 10.0 mV/V. This allows for a large variety of input ranges. However, it sometimes happens that the rated output from the sensor is not exactly 2.0 mV/V or 3.0 mV/V. The AMP320 has a $\pm 10\%$ of R.O. adjustment range so a sensor with an output close to one of the input ranges will work fine.

Appendix A (Noise levels)

Bandwidth	Current Output			Voltage Output
	Sensitivity (mV/V)	Current noise (μA)	Voltage noise (mV)	Voltage noise (mV)
1 kHz	0.5	151	50	30
	1	151	50	25
	1.5	151	50	20
	2	151	50	15
	2.5	151	50	15
	3	151	50	15
	4	151	50	15
10	151	50	50	15
Bandwidth	Current Output			Voltage Output
	Sensitivity (mV/V)	Current noise (μA)	Voltage noise (mV)	Voltage noise (mV)
10 kHz	0.5	151	75	40
	1	151	75	35
	1.5	151	75	30
	2	151	75	25
	2.5	151	75	20
	3	151	75	20
	4	151	100	100
10	151	151	100	15

Appendix B (Specifications)

Environment				
Parameter	Min	Typical	Max	Unit
Operating Temperature	0		70	°C
Storage Temperature	-40°C		85	°C
IP Rating		IP31		

Electrical Specifications				
Parameter	Min	Typical	Max	Unit
Power Supply	14		26	VDC
Current Draw (2)		30		mA
Output Impedance (Voltage)		< 1 Ohms		Ohms
Output Impedance (Current)			700	Ohms
Sensor Impedance	100			Ohms
Bandwidth (3)	1000		10000	Hz
Common Mode Rejection Ratio	120			dB
Output Span Range	-10		10	% of Rated Output
Output Zero Range	-10		10	% of Rated Output
Gain Drift with Temperature	-25	X	25	PPM of FSR per degree Celsius
Gain Non- Linearity (Better than)	-0.01	X	0.01	% of FSR
Zero Drift with Temperature	-25	X	25	PPM of FSR per degree Celsius

(2) No Load Applied (Input or Output) - Power supply must source 150 mA minimum

(3) According ordered option (10kHz, only for sensor's sensitivity of 1 mV/V or greater)

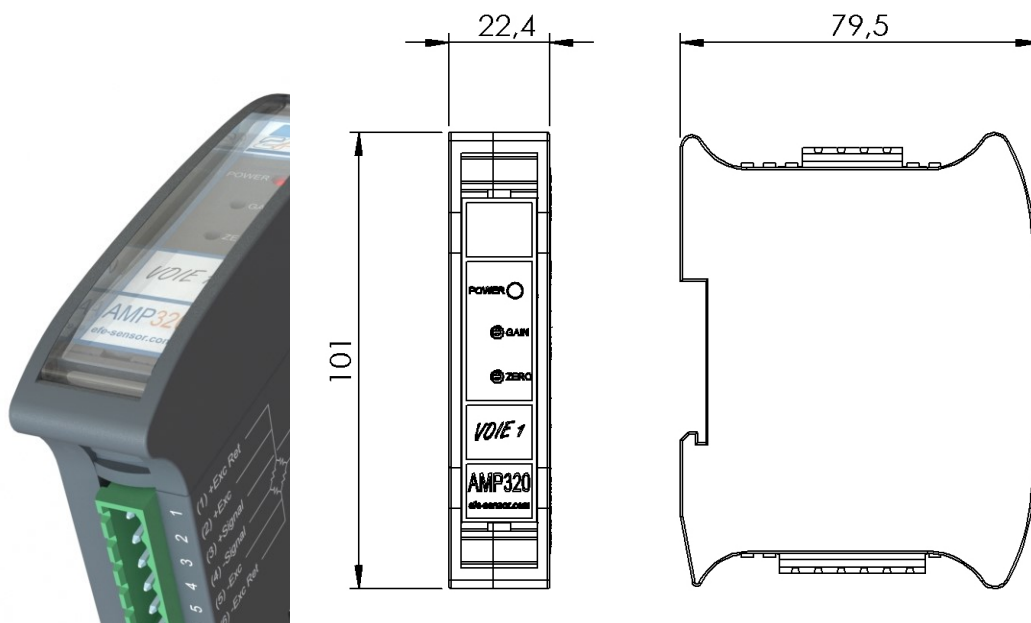

WARNING: DO NOT CONNECT DEVICE TO POWER SUPPLY WHEN POWER SUPPLY IS ALREADY ON