



Aalto University  
School of Chemical  
Technology

# Surface Plasmon Resonance (SPR)

CHEM-L2000

Eero Kontturi

27<sup>th</sup> February 2024

# Outline

(1) SPR – general issues

(2) Theory

- Existence of surface plasmons
- SPR phenomenon

(3) Instrumentation, measuring and interpretation

(4) Applications of SPR

- Thickness and refractive index
- Following layer-by-layer deposition
- Following attachment of antibodies

# SPR in general

- Light excitation causes the formation of plasmons on a metal surface
- The plasmons propagate on the metal-sample surface and are affected by the changes in the sample
- Enables *in situ* monitoring of, e.g., adsorption occurring on an ultrathin film

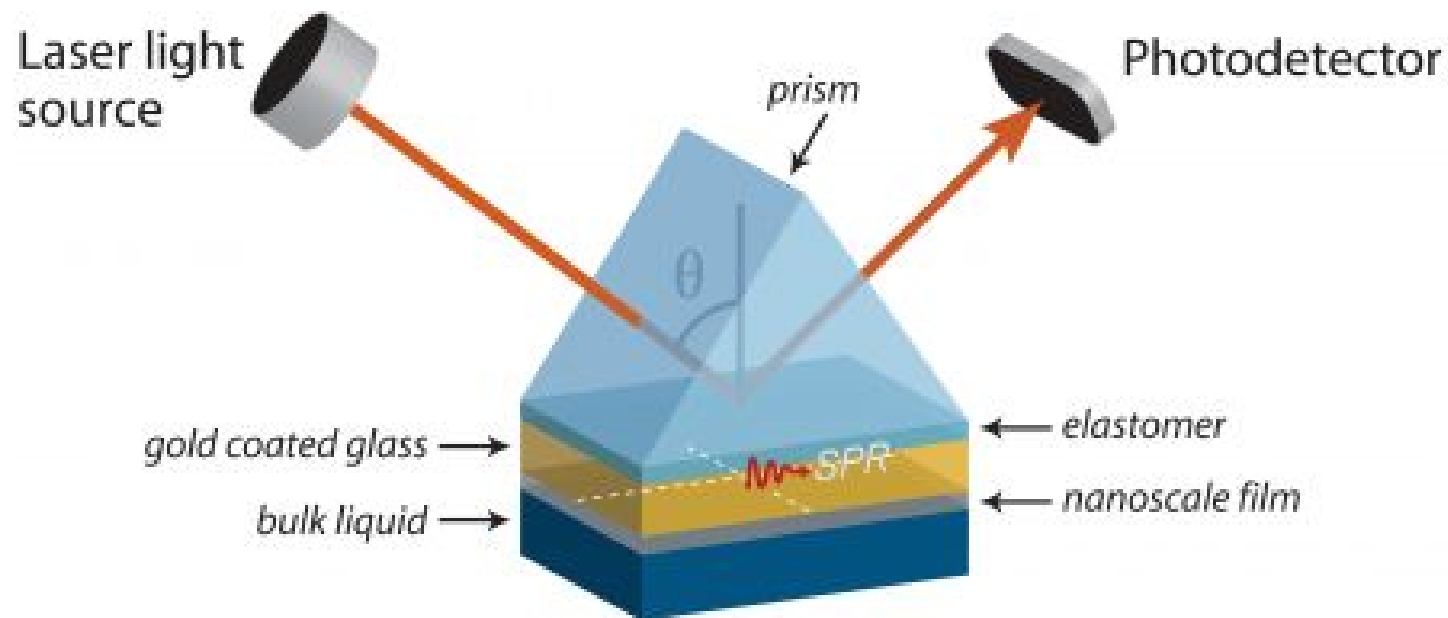

# SPR in general

## Main applications:

- Following protein immobilization
  - Binding of proteins (to antibodies)
  - Kinetics of binding
  - Analyzing mutant proteins
- Polymer adsorption studies
  - Adsorption kinetics
  - Following layer-by-layer deposition
  - Equilibrium measurements (affinity and enthalpy)
- Interfacial reactions

**In essence, SPR is generally applied to follow binding of an object (macromolecule, nanoparticle, colloid) on a surface and the possible changes occurring in the bound layer.**

# Theory

# What are surface plasmons?

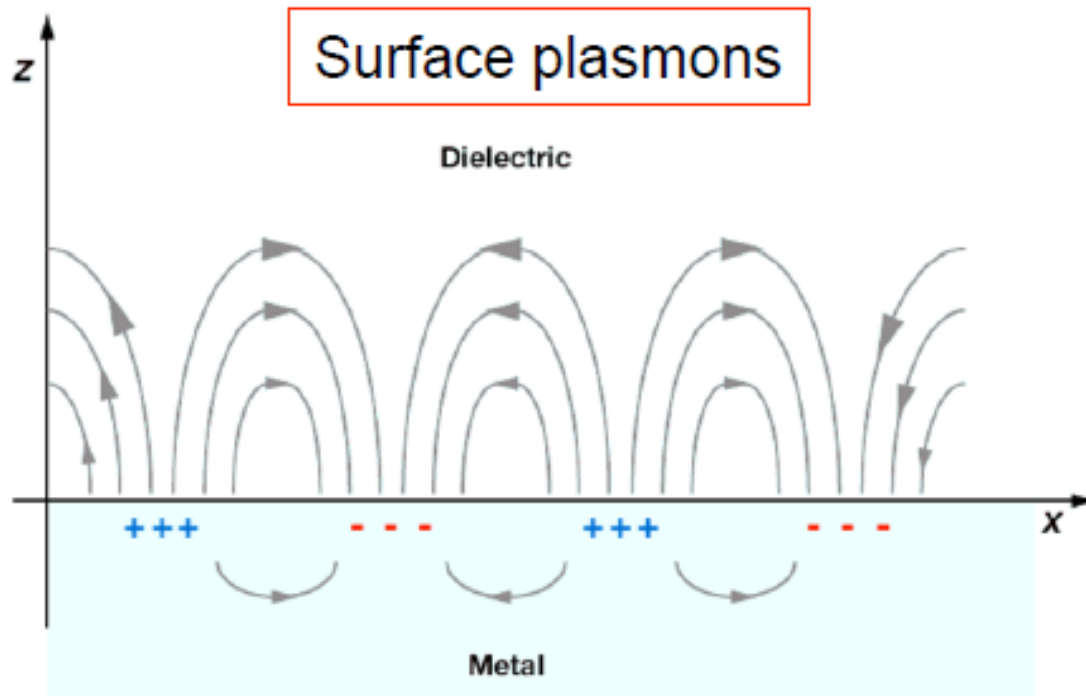

- **Plasmons** are charge density oscillations of the nearly free electron “liquid” or “gas” in metals
- **Surface plasmons** are electromagnetic waves that propagate along a metal/dielectric interface

Note: a dielectric is an electrical insulator that can be polarized by an electric field.

# What are surface plasmons?

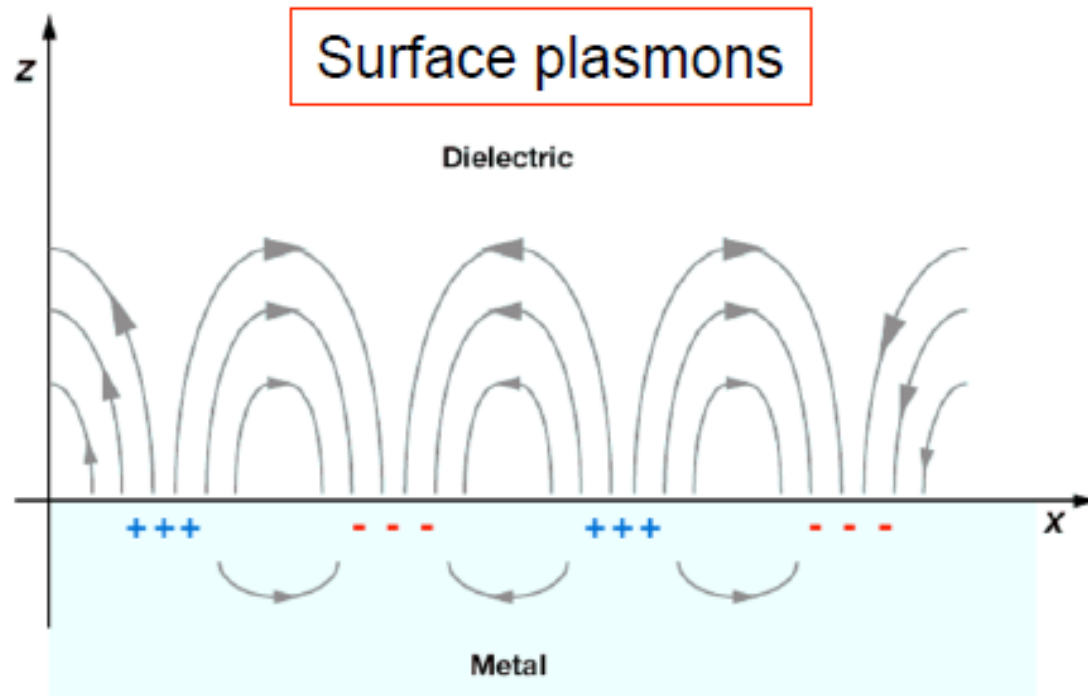

- **Plasmons** are charge density oscillations of the nearly free electron “liquid” or “gas” in metals
- **Surface plasmons** are electromagnetic waves that propagate along a metal/dielectric interface

Surface plasmons in SPR occur usually at air/metal or water/metal interface, excited by the electric field created by electromagnetic radiation from IR to visible light wavelengths.

# Total internal reflection (TIR) and surface plasmons

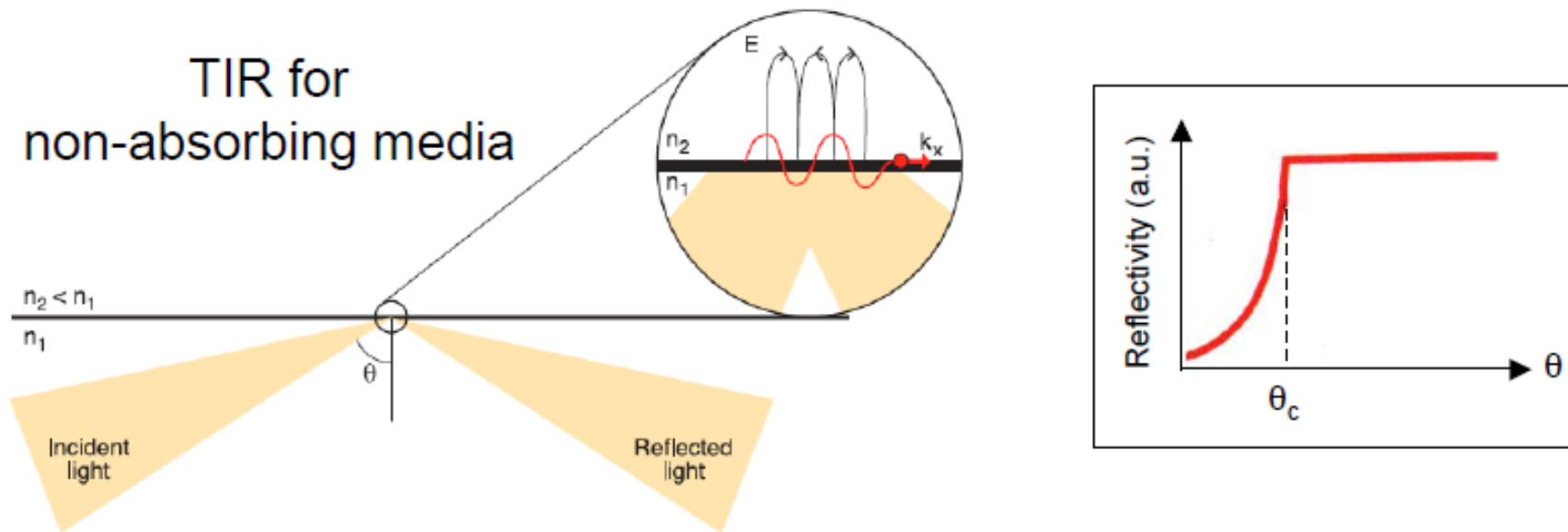

- A fully reflected beam causes an evanescent wave to penetrate into the low refractive index medium at the interface between two materials
- Evanescent wave is effectively an electric field that decays exponentially over a distance of  $\frac{1}{4}$  wavelengths beyond the surface



# Total internal reflection (TIR) and surface plasmons

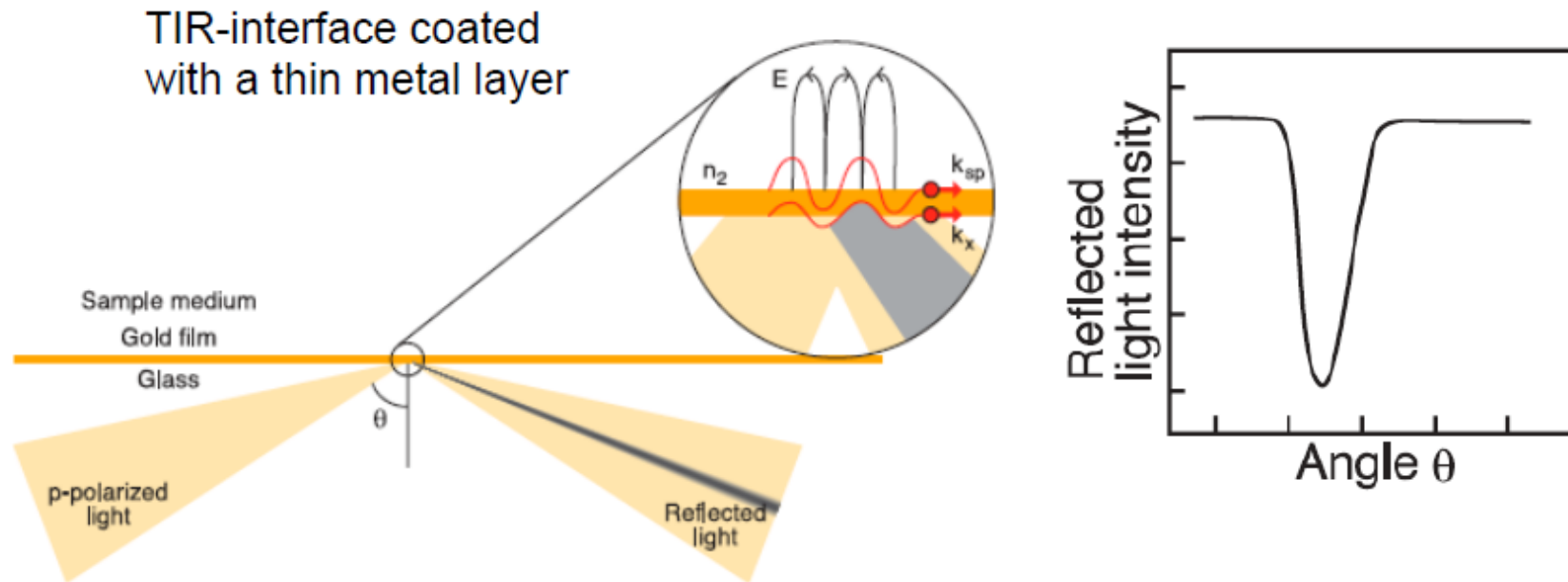

- At a certain incident angle or wavelength, the electromagnetic component of the p-polarized light penetrates the metal layer and energy is transferred to the metal's electrons → surface plasmons emerge → A decrease in reflected light intensity occurs

# Surface plasmon resonance

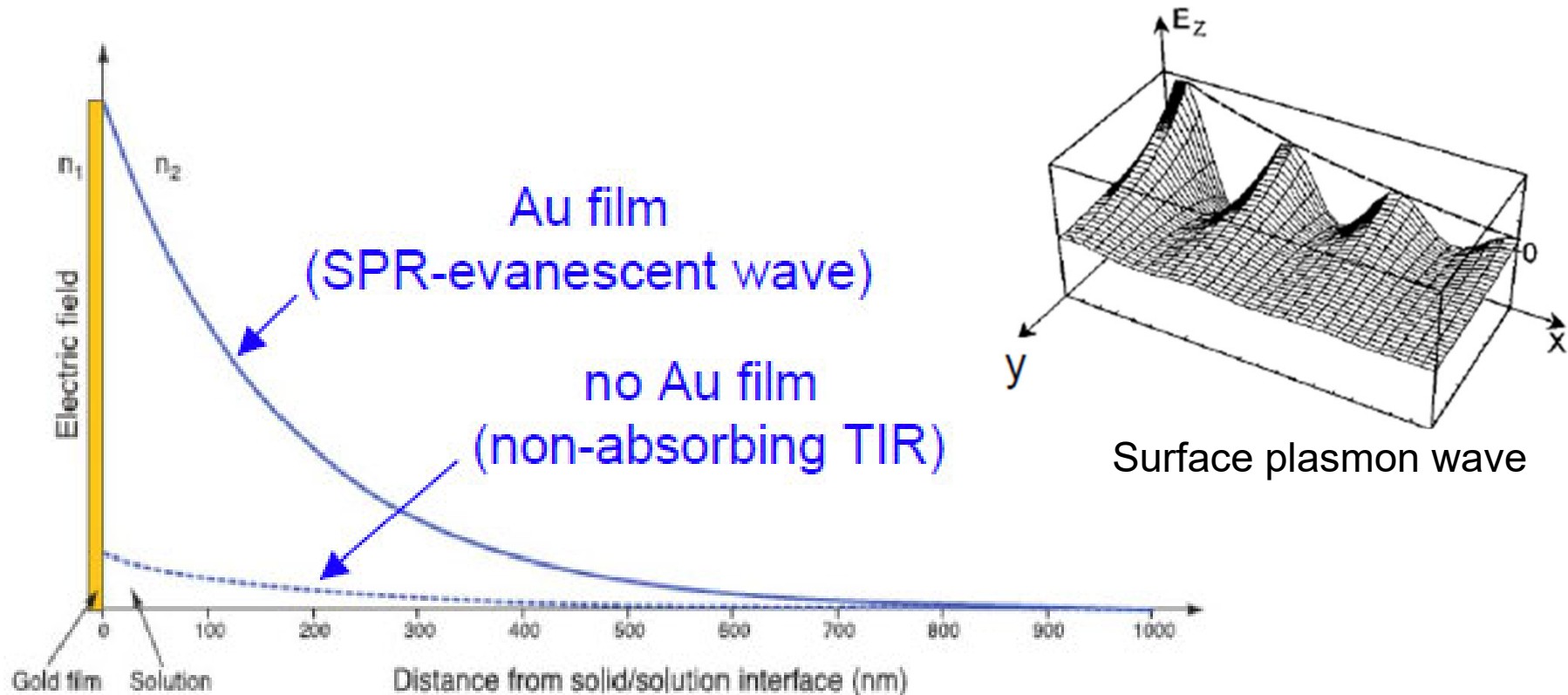

- The surface plasmon wave is electromagnetic and surface propagating  
→ The surface plasmon wave significantly enhances the evanescent electric field amplitude

# Characteristics of the SPR evanescent wave

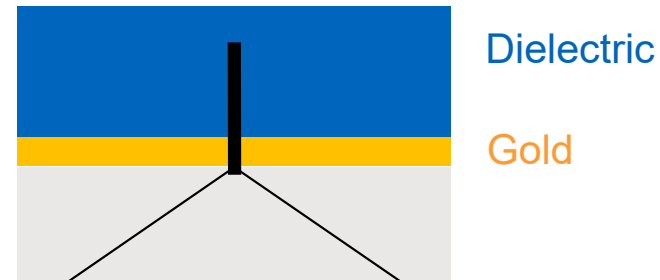

Metal layer supporting SPW	Gold	
Wavelength	$\lambda = 630 \text{ nm}$	$\lambda = 850 \text{ nm}$
Propagation length ( $\mu\text{m}$ )	3	24
Penetration depth into metal (nm)	29	25
Penetration depth into dielectric (nm)	162	400
Concentration of field in dielectric (%)	85	94

# How SPR reacts on material changes on the surface

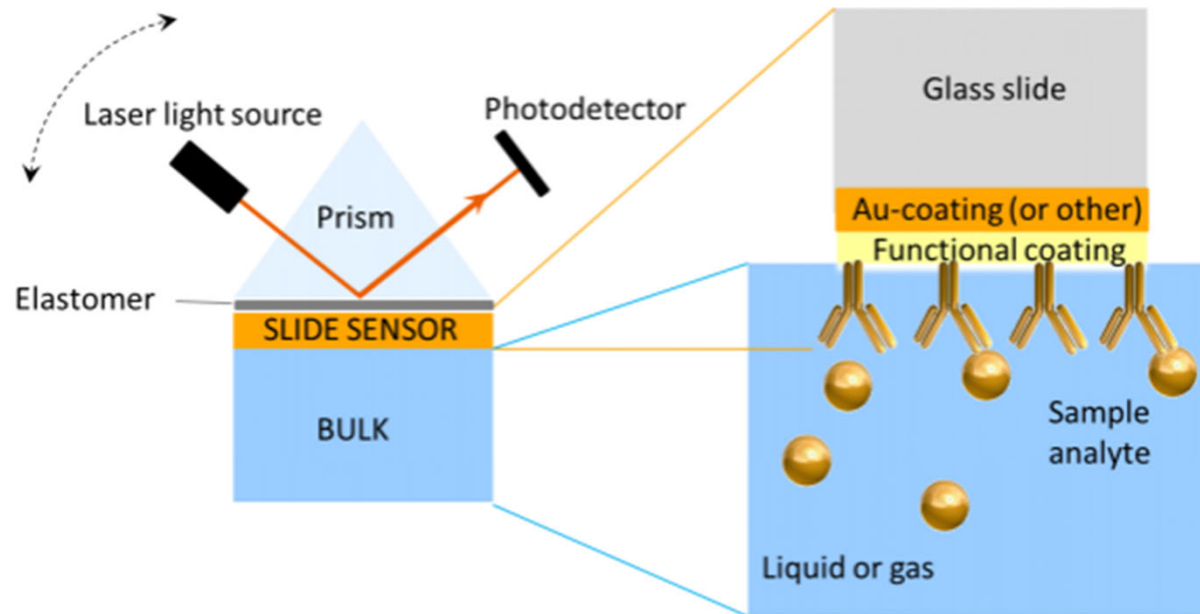

- The conditions of the SPR are sensitive to the refractive index at the metal-dielectric interface
- Added material / changes in the material alter the refractive index  
→ Velocity of the surface plasmons is changed

# How SPR reacts on material changes on the surface

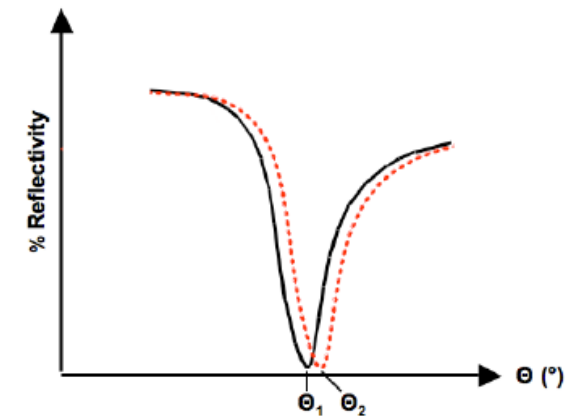
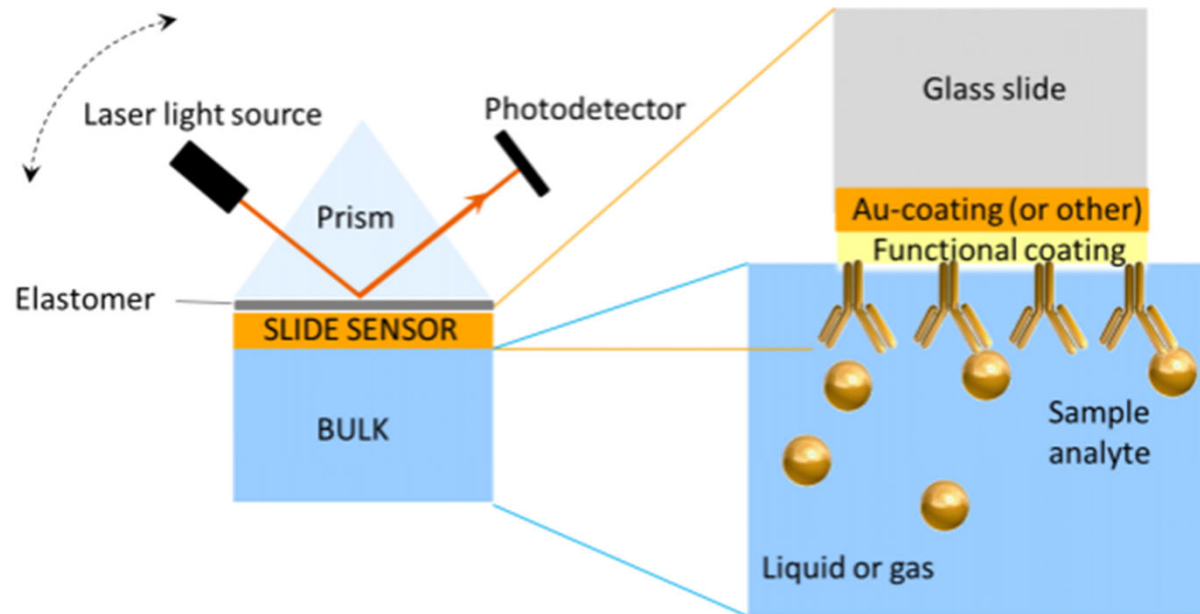

- The change in plasmon velocity alters the incident light vector (e.g., angle) required for surface plasmon resonance and minimum reflection
- The exact position of minimum reflection (resonance) bears information on the interfacial mass coverage / thickness of the layer(s)

# Instrumentation, measuring, and interpretation

# Basic instrumental configurations

Grating

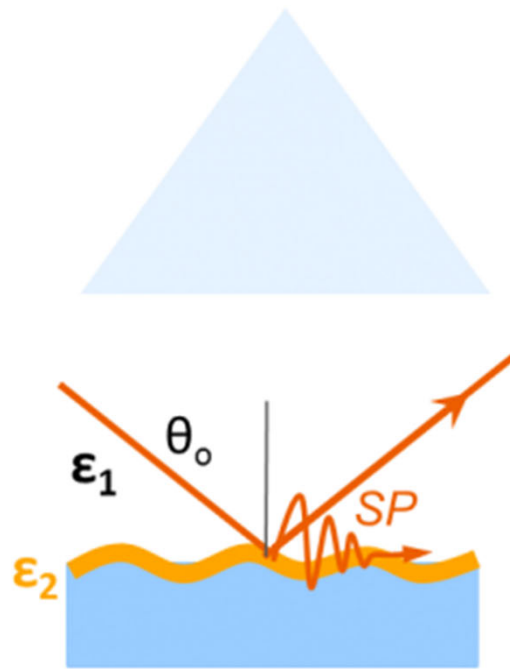

Incident light beam goes through the sample

Otto

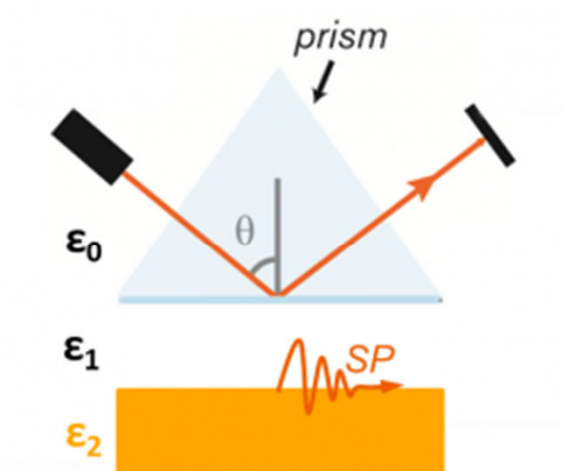

Gap between reflection and the metal

Kretschmann

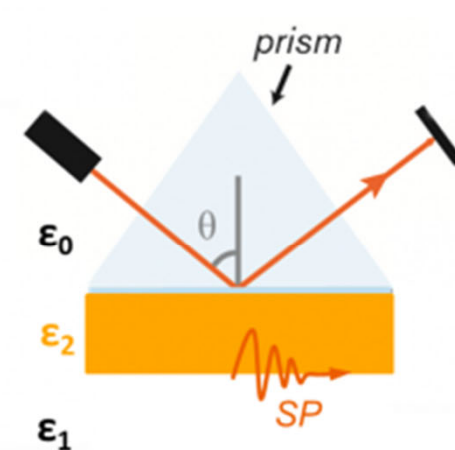

The most common contemporary setup: no gap and the beam does not go through the sample

# Basic detection modes

Intensity of the light is recorded at a fixed angle

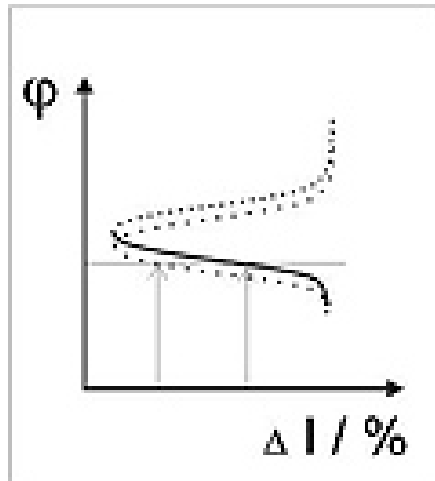

Monochromatic light source, angle varied

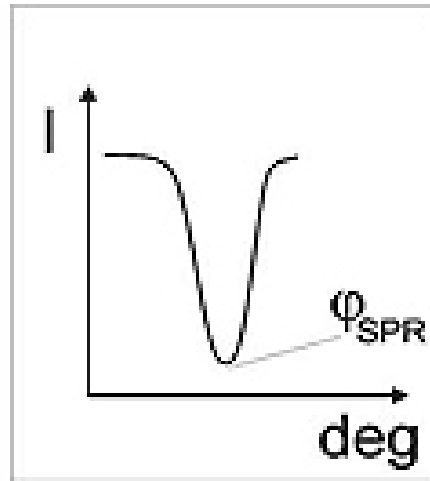

Fixed angle, the sample is irradiated with white light (whole spectrum) and the wavelength for resonance is detected

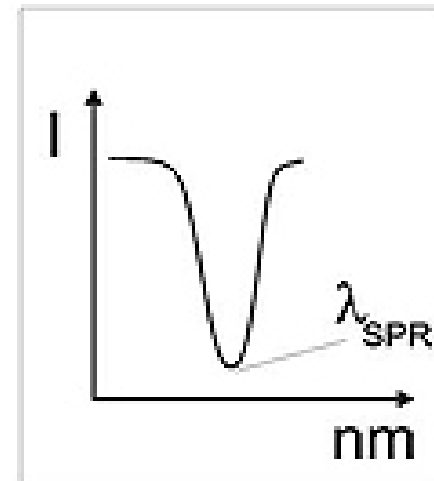



# Basic detection modes

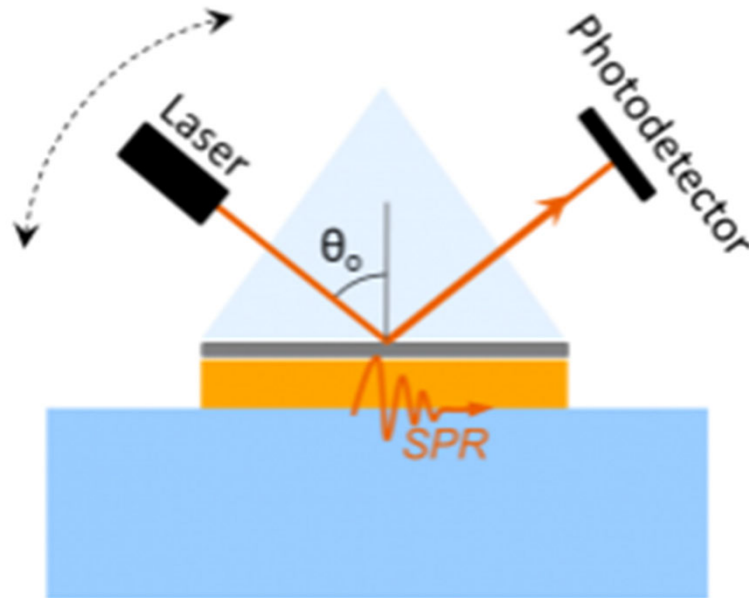

SPR Navi (commercial name)

- Merges fixed angle scan and angular scan
- Enables a wider range of angles *and* refractive indices

# Basic instrumentation

## LIQUID PATH

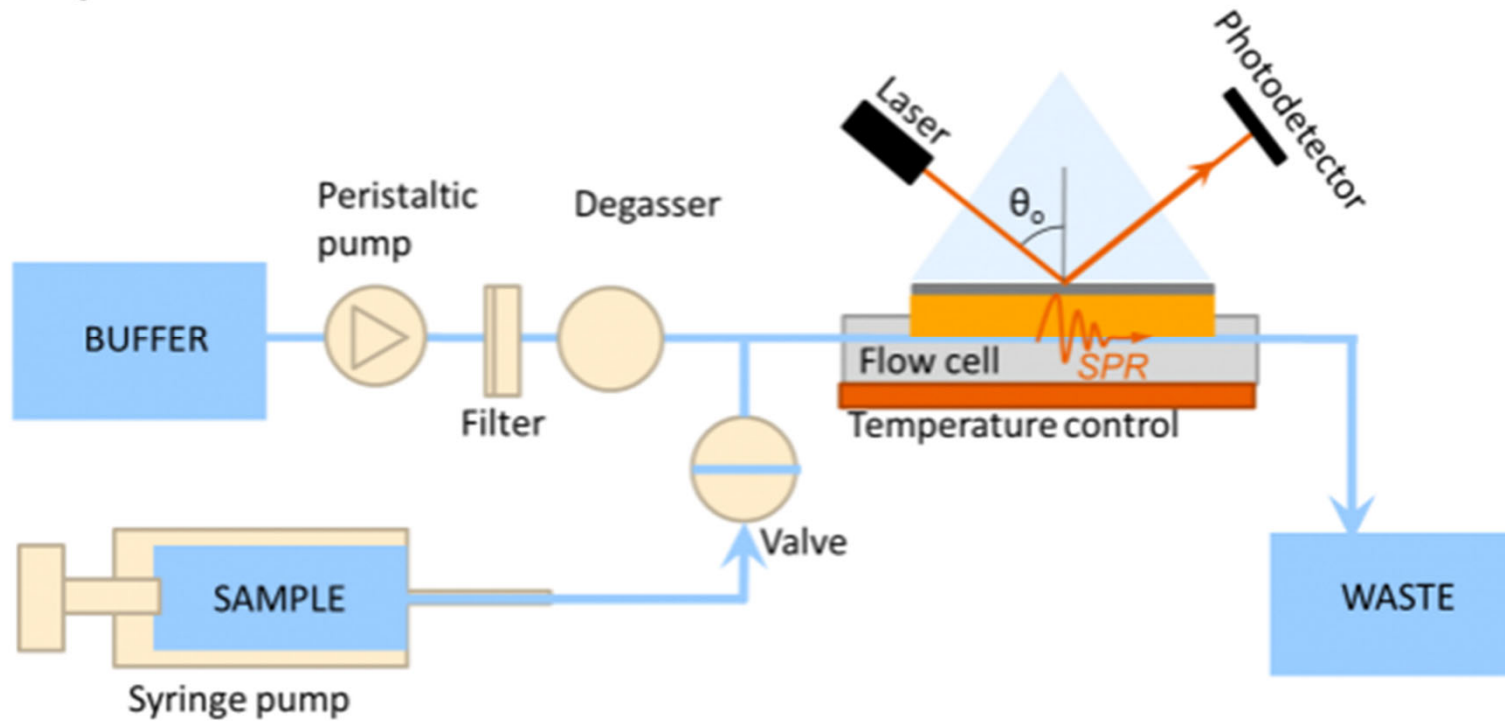

# Data interpretation during adsorption

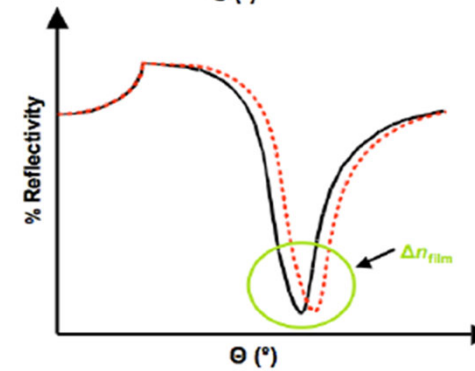
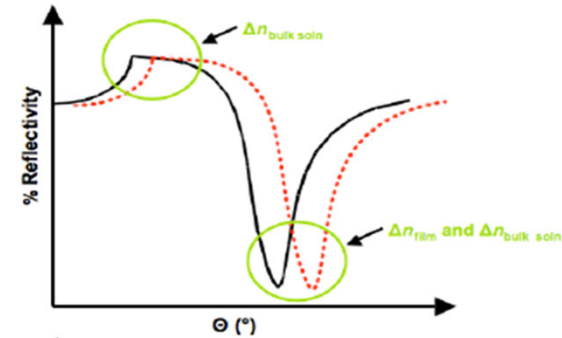
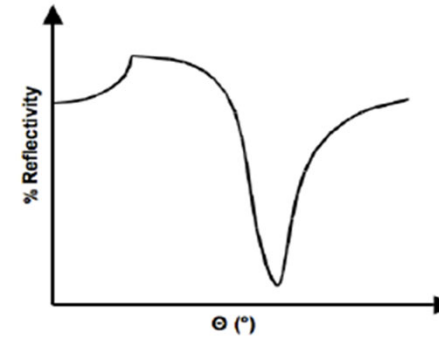
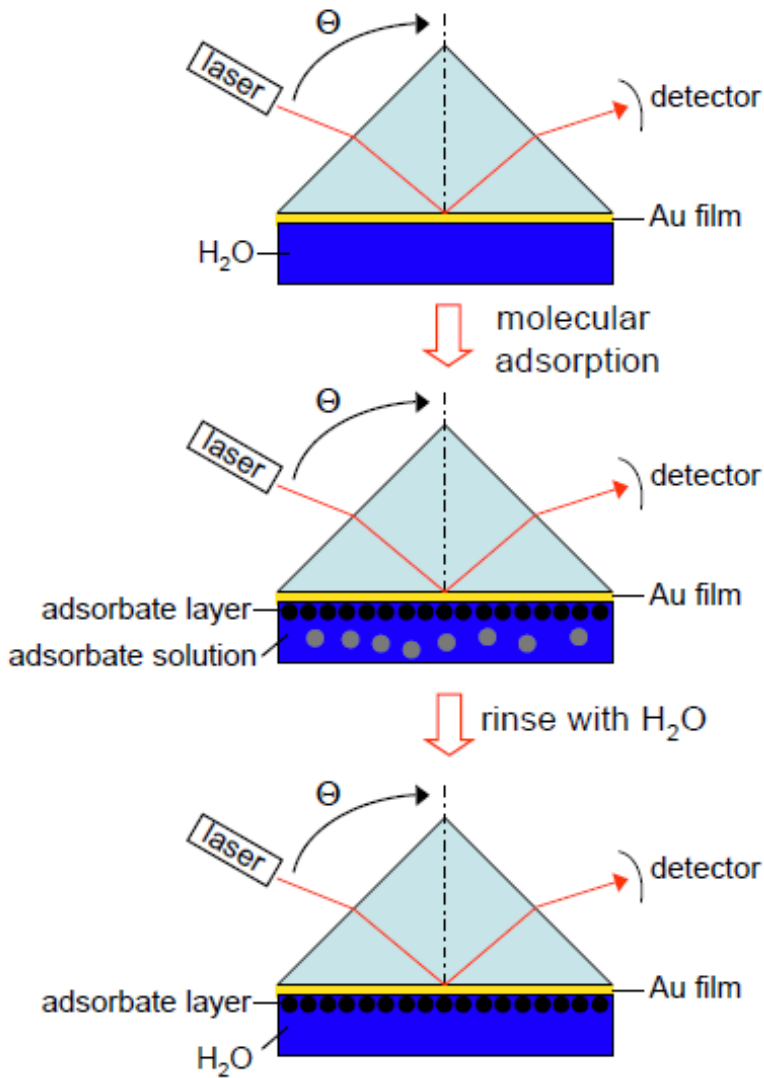

# Data interpretation during adsorption

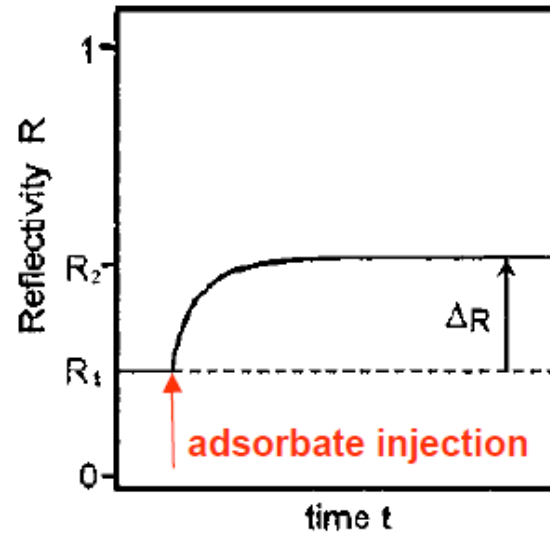
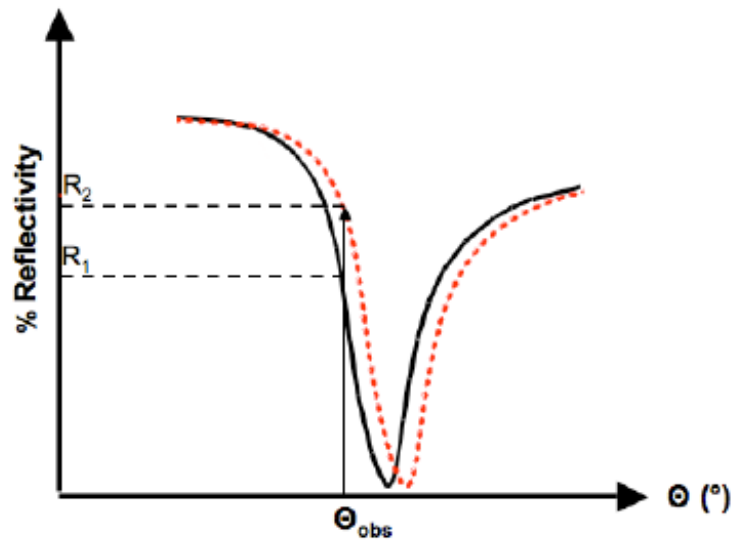

Time-dependent curve may be constructed from either reflectivity differences

or

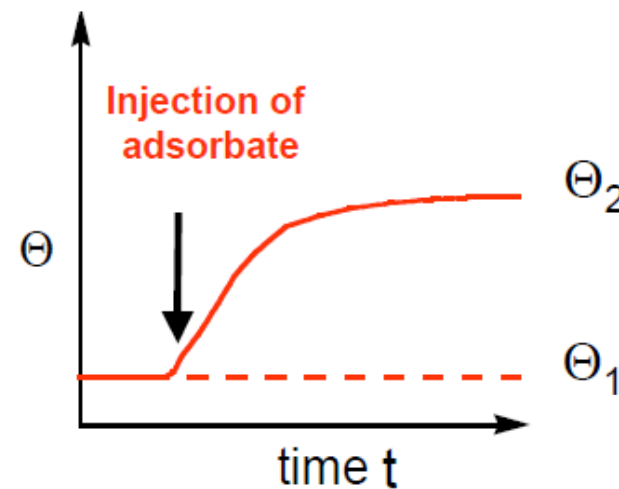
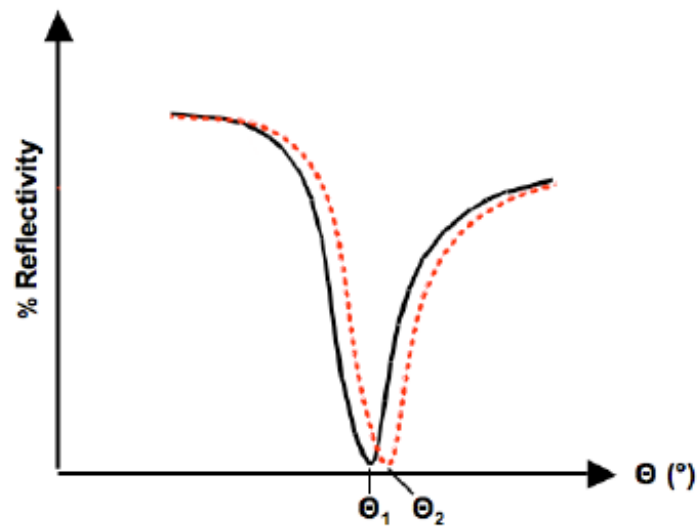

angular differences (at reflection minimum)

# Data interpretation: sensorgram

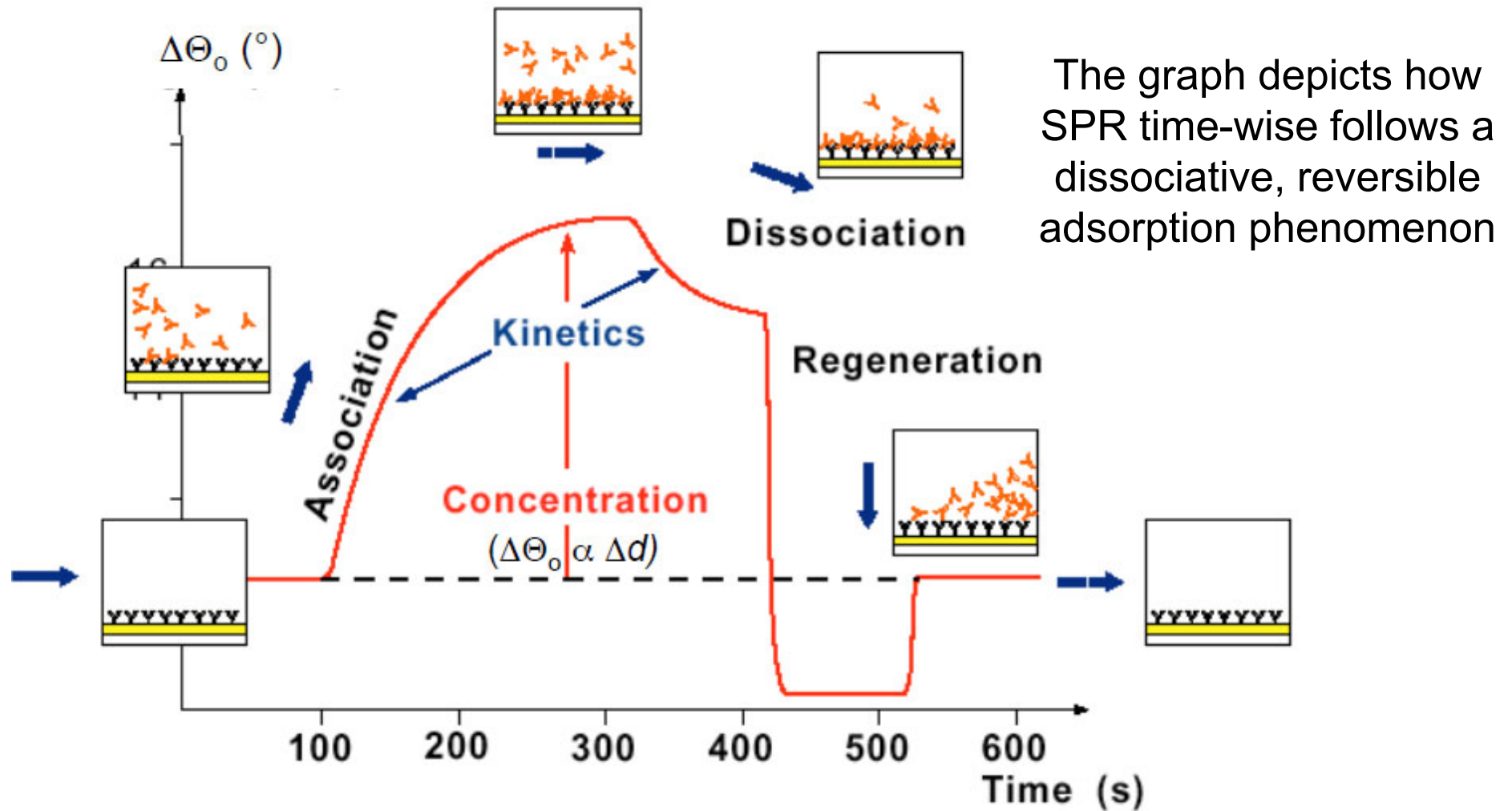

# Data interpretation: sensorgram

- Following of adsorption (or binding) is the most common use for SPR
- Nowadays, the time-dependent sensorgram is used very often in the adsorption measurements
- When using sensorgrams, the analyst does usually not even see the raw data (reflection curves)
- Often, the SPR software converts the sensorgram directly into mass or thickness data if the user inputs the refractive indices of the elements there beforehand

# Modelling of SPR

- SPR curves can be modelled using the Fresnel equations (see previous lectures) for a multilayered structure
- Accurate, more reliable data on the properties of the adsorbed layer can be gained this way

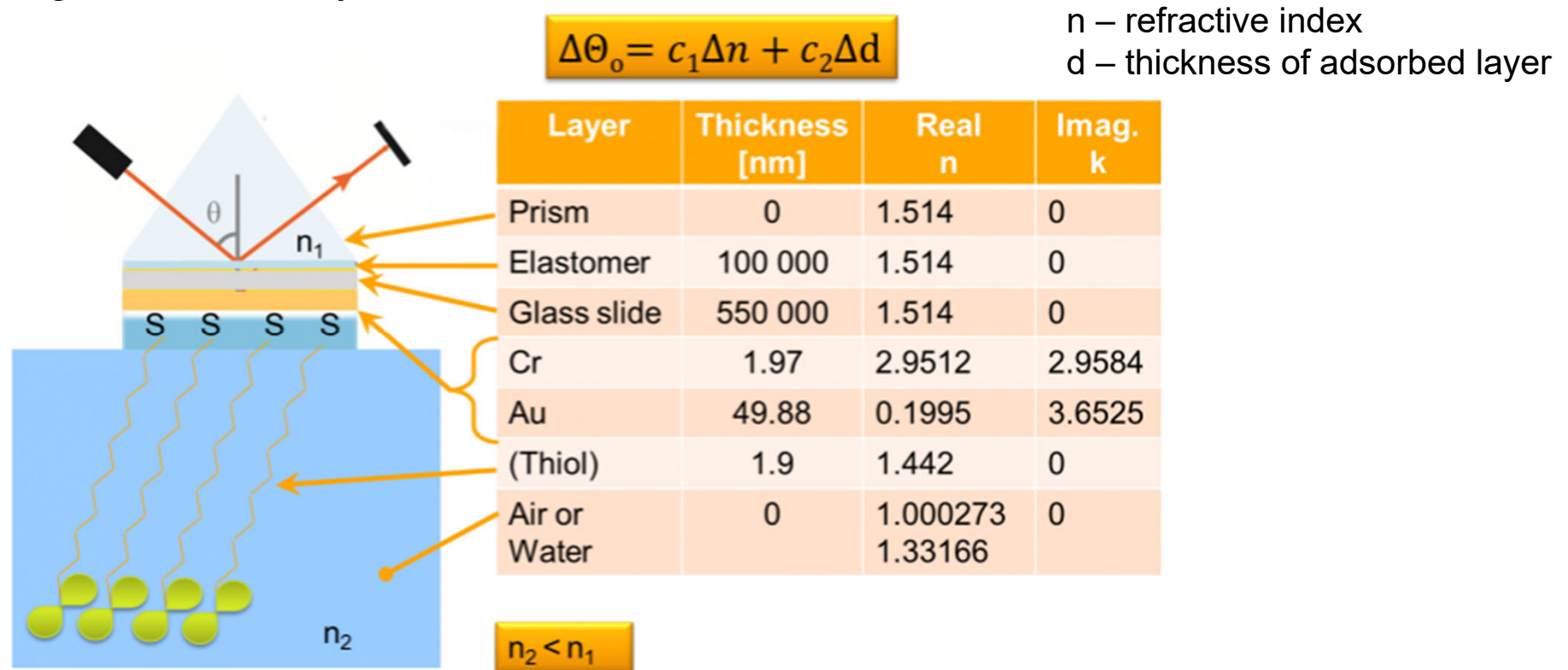

# Applications



# Thickness of Langmuir-Blodgett films

- Langmuir-Blodgett (LB) films of different thicknesses are prepared on a gold substrate (SPR sensor)
- The exact thickness values are gained from SPR measurements after the film preparation (*ex situ*)

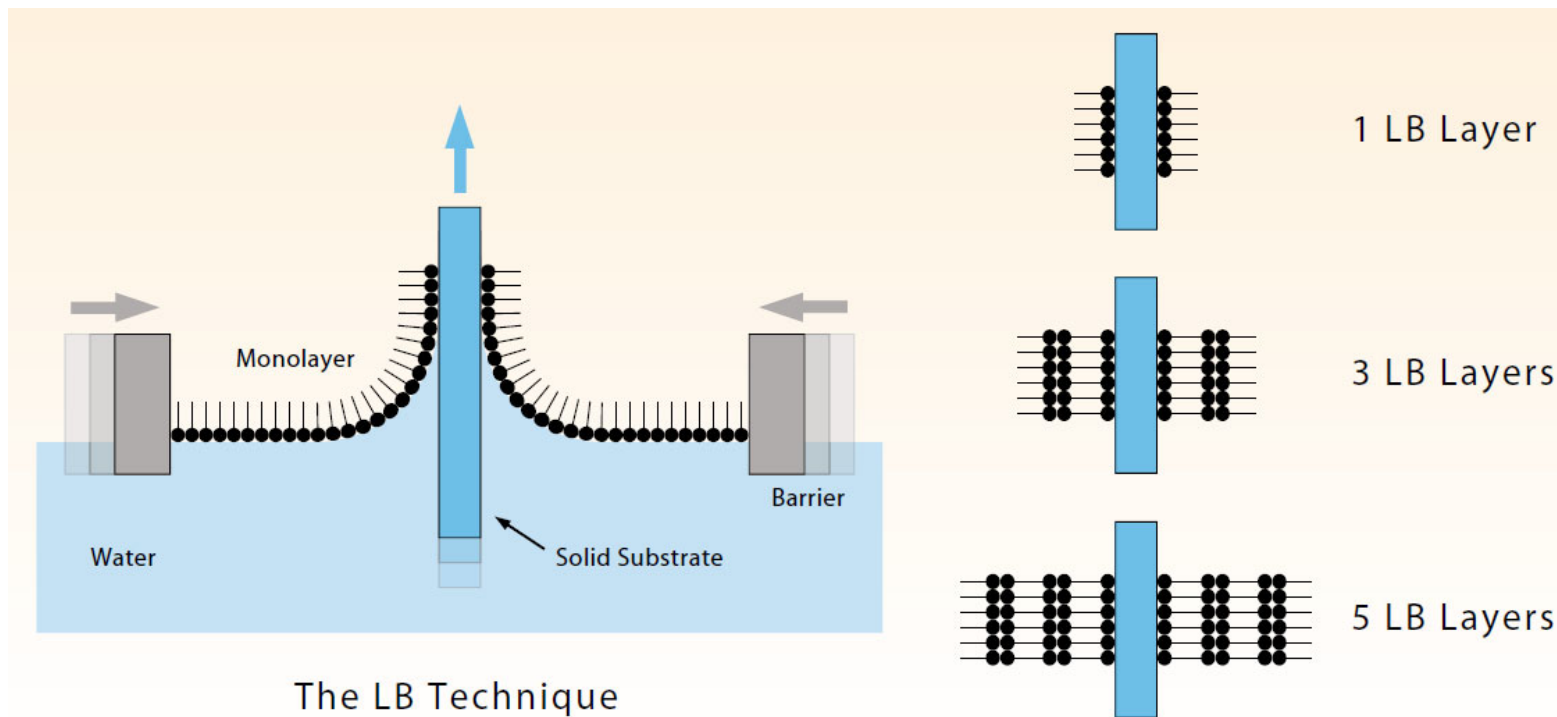

# Thickness of Langmuir-Blodgett films

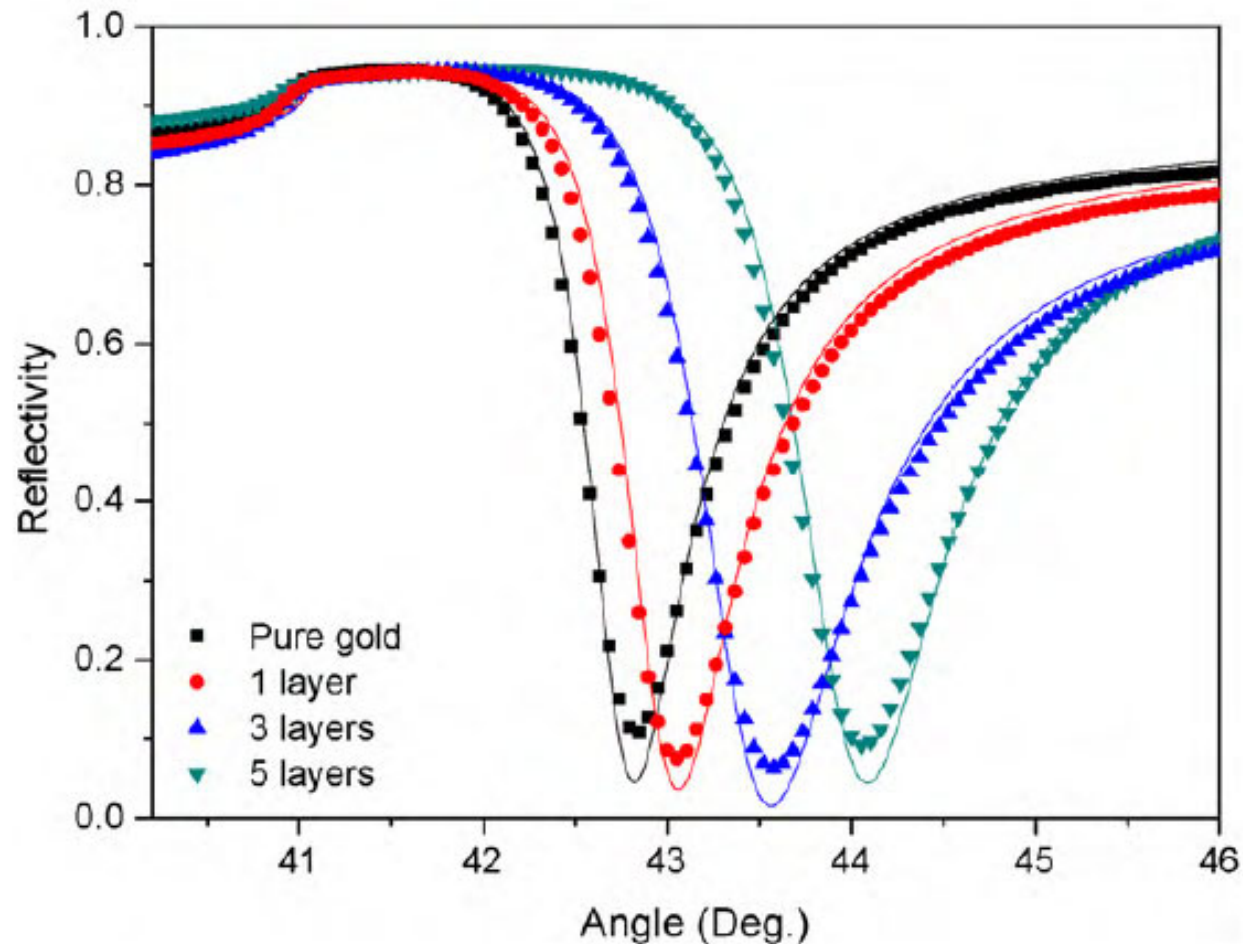

- Layers of stearic acid are deposited on gold
- Data is fitted to find out the thickness in high accuracy

# Thickness of Langmuir-Blodgett films

- Angle change in SPR indicates the thickness (deduced from modelling)

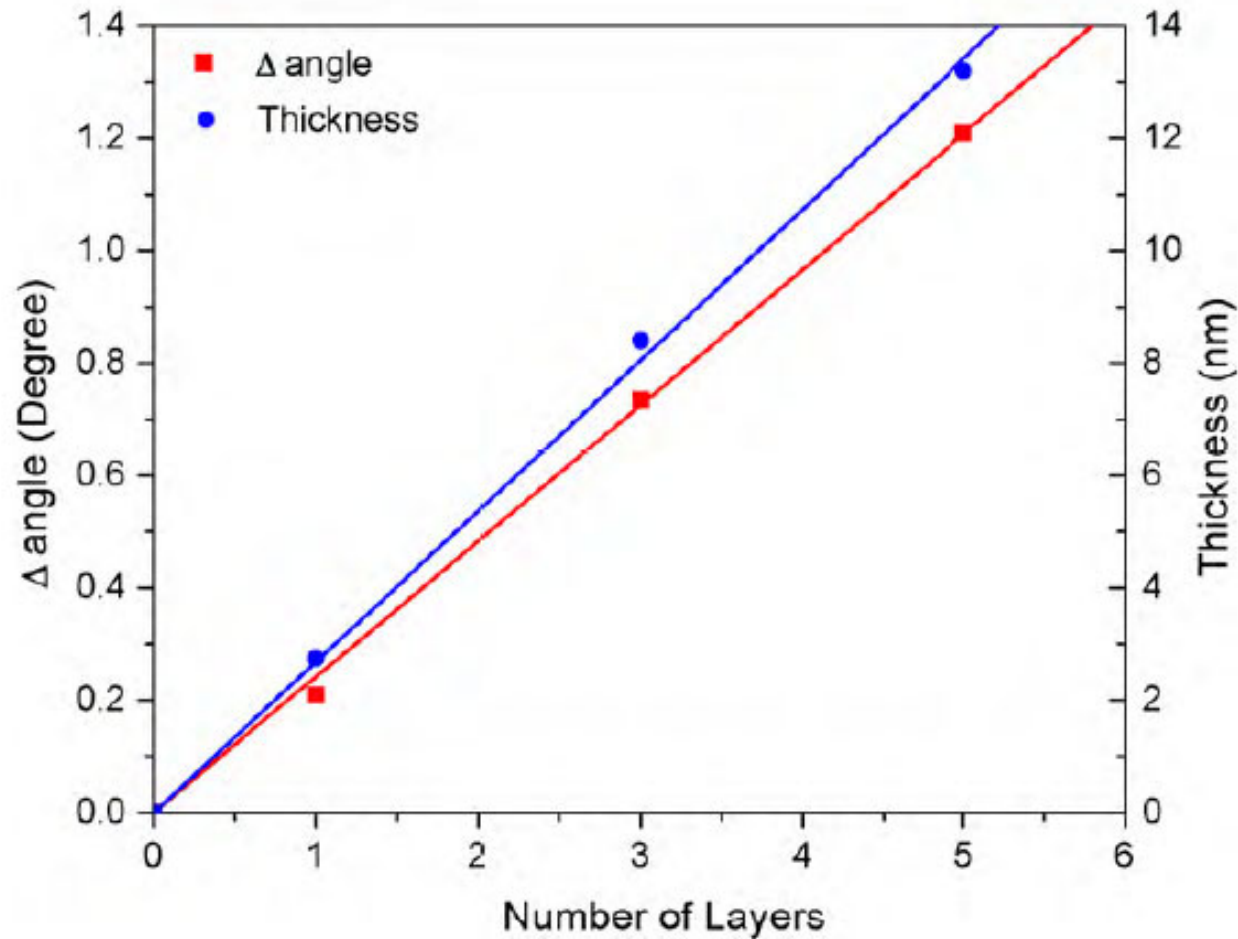

# Refractive index of Langmuir-Blodgett films

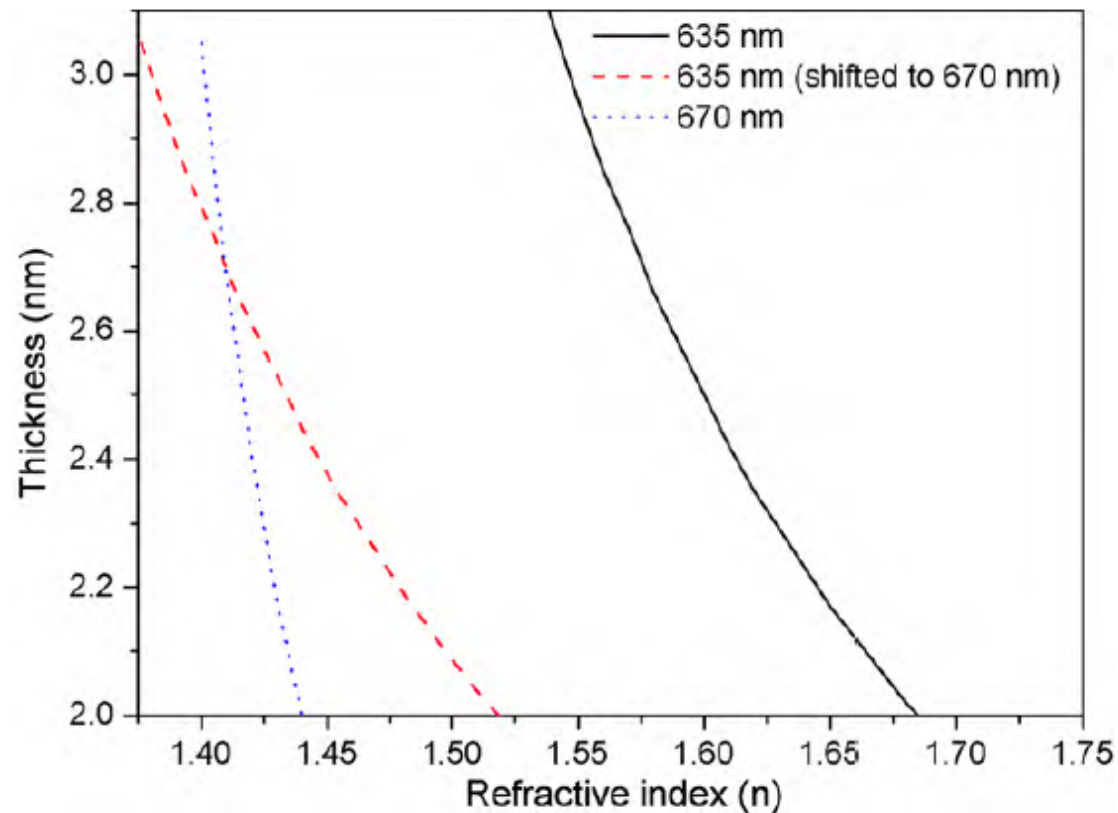

- The LB film is monitored by SPR with two distinct wavelengths (635 and 670 nm)
- Refractive index depends slightly on the wavelength
- Film thickness is plotted as a function of refractive index (gained from modelling)

# Refractive index of Langmuir-Blodgett films

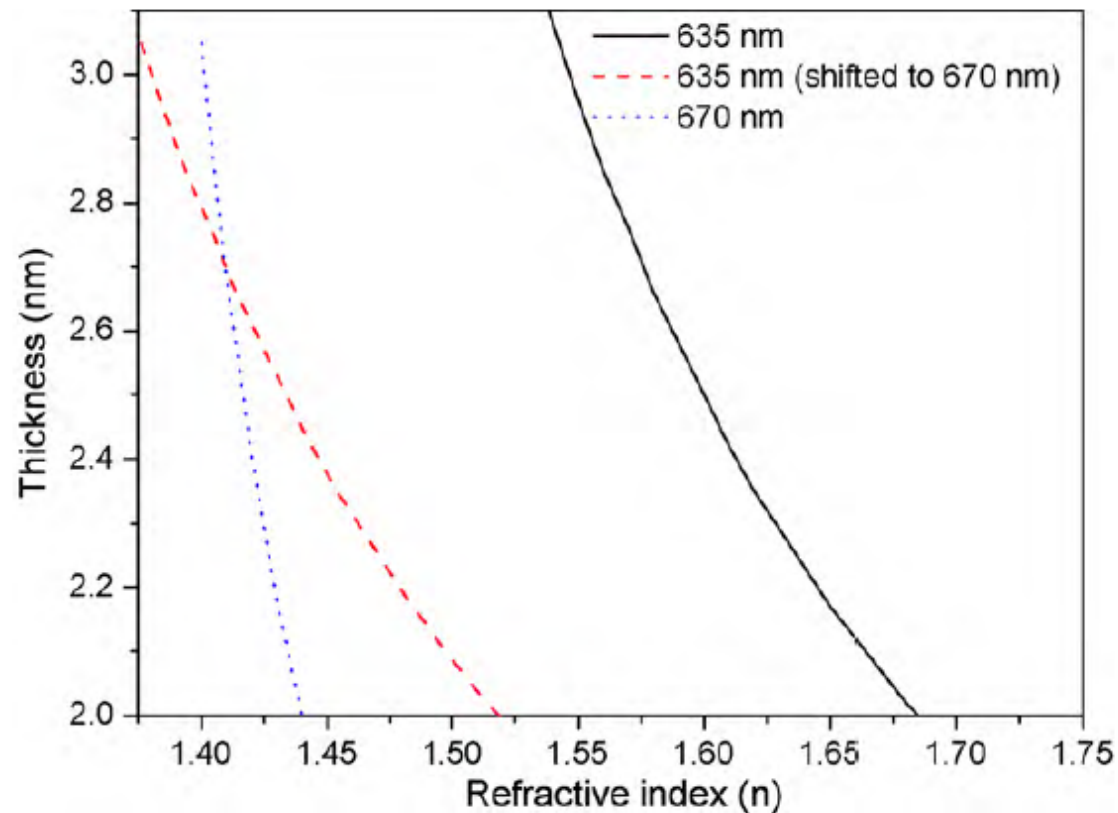

- The other refractive index is mathematically shifted to match the other one
- The intersection point yields the definitive refractive index of the material

# Investigating layer-by-layer deposition

- polyelectrolytes of opposite charges can be deposited one after another
- experimentally the easiest technique: requires only polyelectrolyte solutions and washing in between

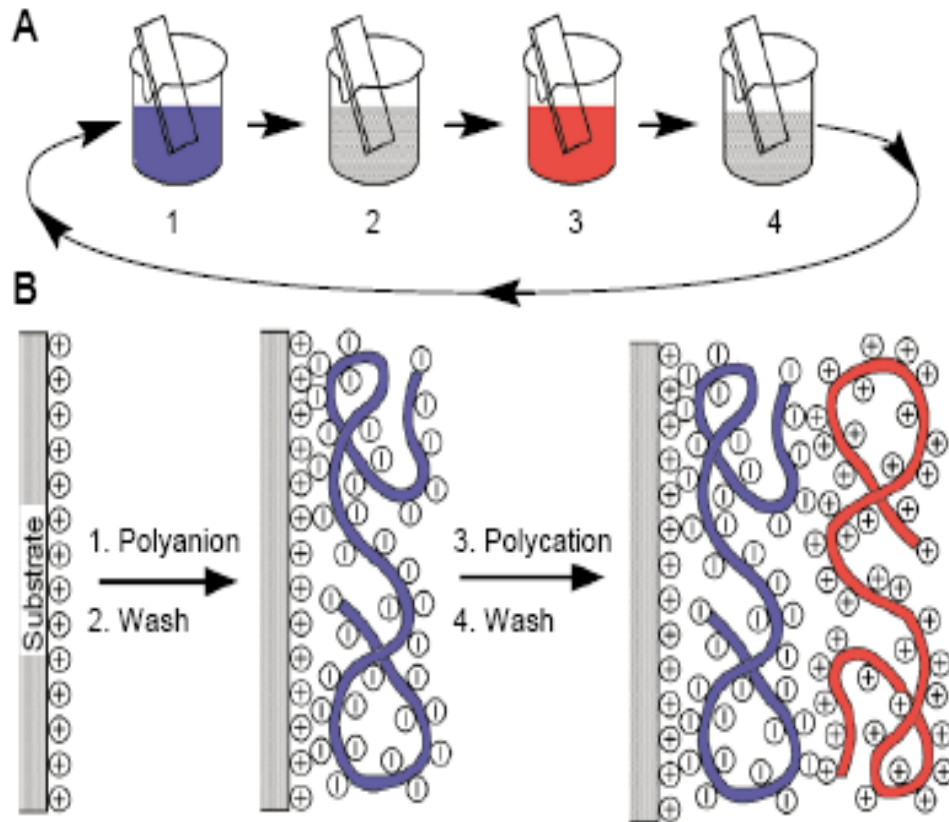

Science **1997**, 227, 1232.

# Investigating layer-by-layer deposition

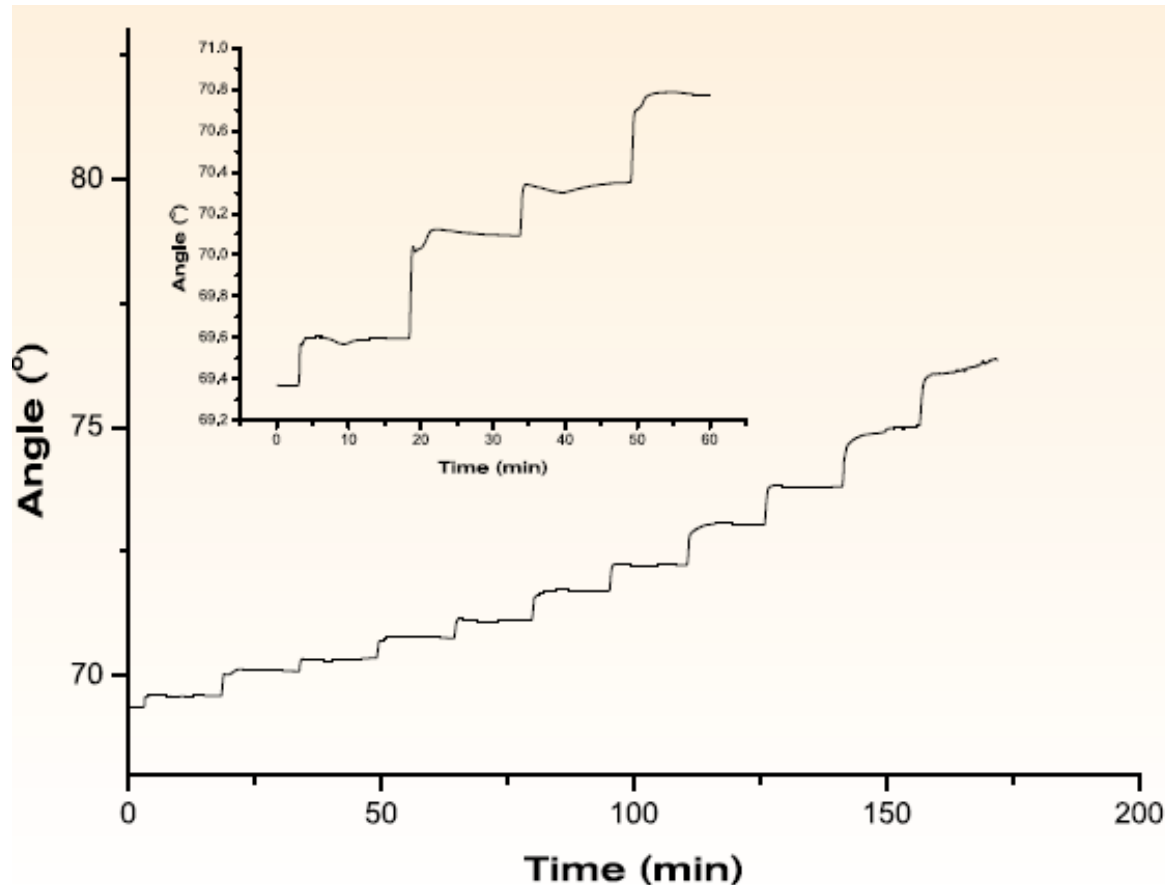

- Sensorgram can be used to follow the in situ build-up of multilayer
- It appears that in the case of these particular polyelectrolytes, the adsorption is very fast and rinsing brings about little desorption

# Investigating layer-by-layer deposition

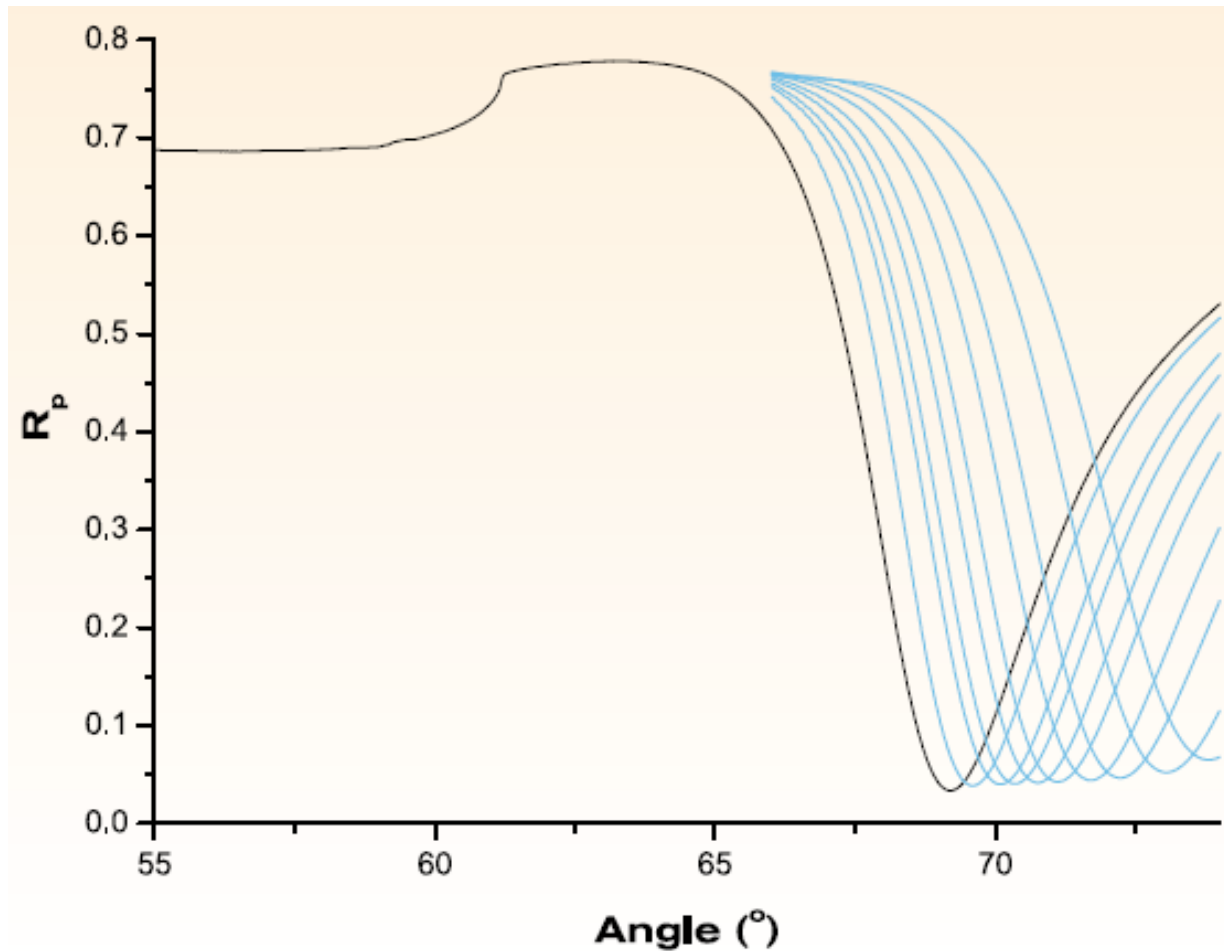

- Modelling of the raw data leads to accurate determination of the thickness



# Investigating layer-by-layer deposition

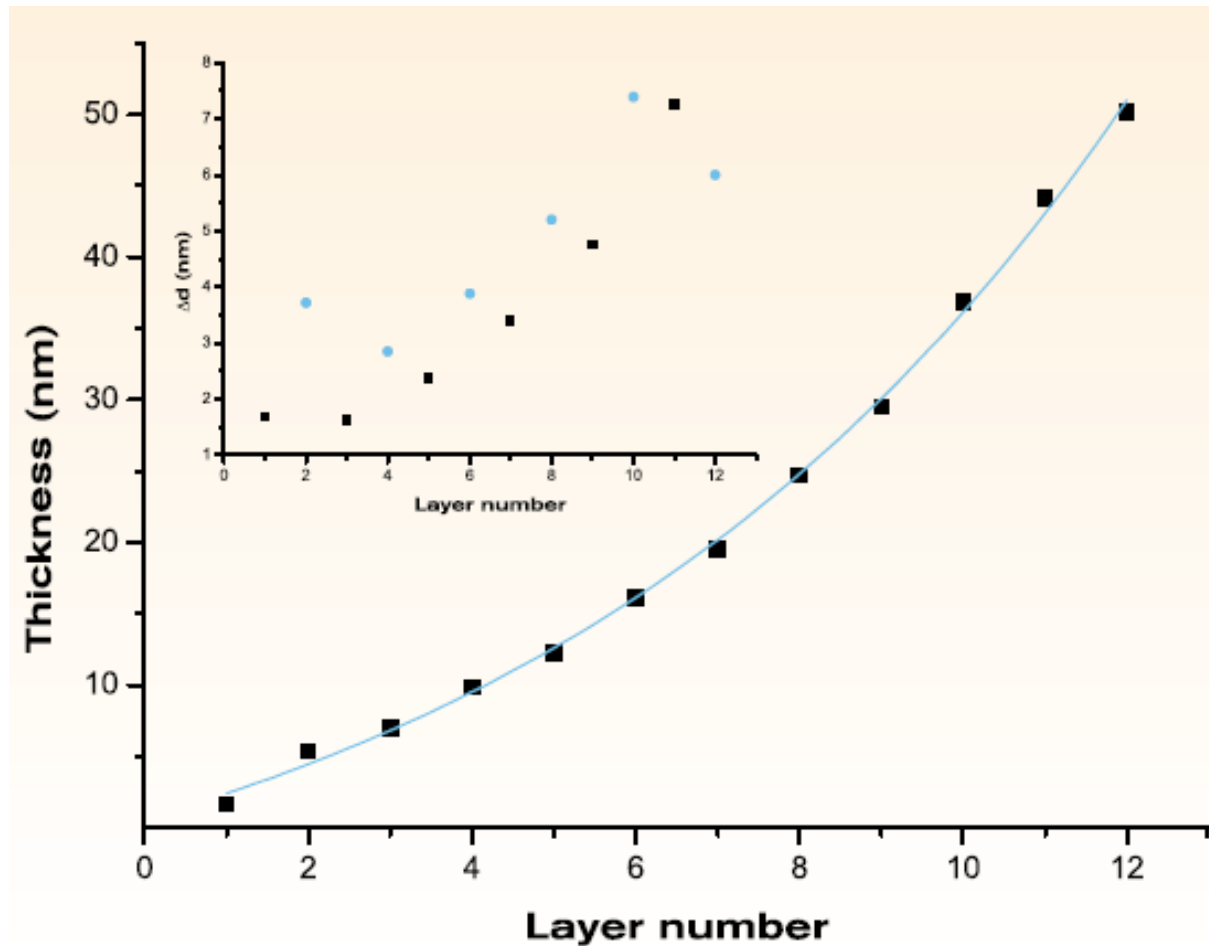

Result:  
In situ investigation of  
layer-by-layer  
deposition

# Antibody conjugation on cellulose

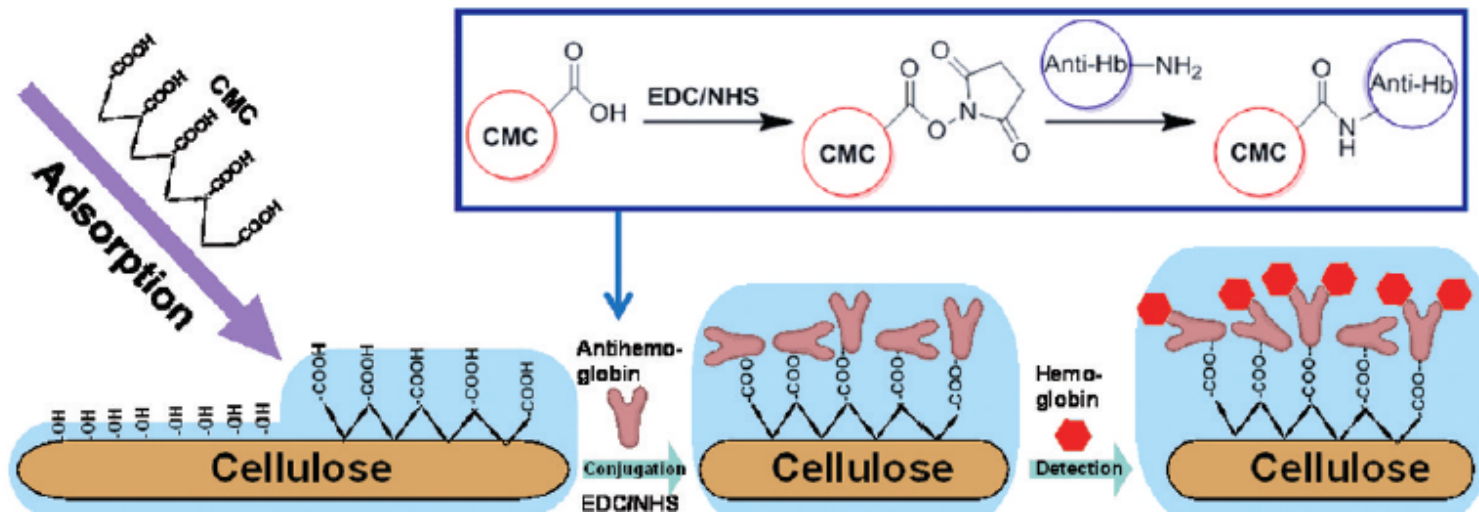

- Carboxymethyl cellulose (CMC) is adsorbed on cellulose surface
- Carboxylic groups are modified with so-called EDC/NHS mechanism
- An antibody (antihemoglobin, Anti-Hb) is attached on the surface
- Because hemoglobin binds selectively onto its antibody, the system can be used as a sensor for hemoglobin

# Antibody conjugation on cellulose

EDC/NHS + antibody attachment followed in an SPR sensorgram

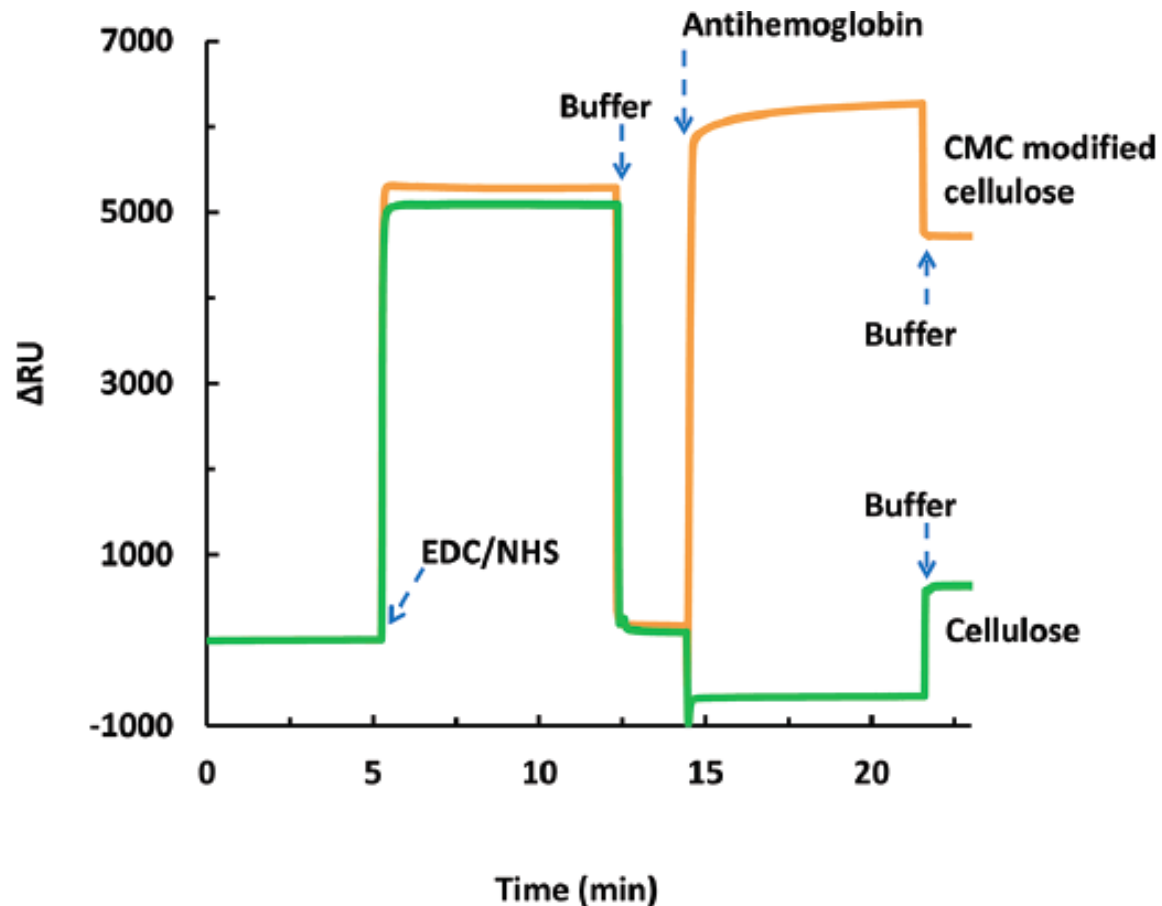

- Initial attachment of CMC by adsorption is absolutely necessary for the antibody binding to occur on cellulose

# Summary

# Summary

- SPR is based on the sensitivity of surface plasmons on a metal/dielectric surface: small changes in the refractive index of the dielectric (sample) affect the plasmon speed significantly
  - Small mass changes on the surface can be monitored
  - SPR can be used to monitor, e.g., adsorption (mass change on surface)
- Sensorgrams yield in situ information on, e.g., adsorption or interfacial reactions
- Modelling can be used to extract the exact thickness and refractive index of a film / adsorbed layer