

Information Processing in the Primate Retina: Circuitry and Coding

G.D. Field and E.J. Chichilnisky

The Salk Institute, La Jolla, California 92037; email: ej@salk.edu

Annu. Rev. Neurosci. 2007. 30:1–30

First published online as a Review in Advance on
March 2, 2007

The *Annual Review of Neuroscience* is online at
neuro.annualreviews.org

This article's doi:
10.1146/annurev.neuro.30.051606.094252

Copyright © 2007 by Annual Reviews.
All rights reserved

0147-006X/07/0721-0001\$20.00

Key Words

vision, parallel pathways, neural coding, synchrony, retinal ganglion cells

Abstract

The function of any neural circuit is governed by connectivity of neurons in the circuit and the computations performed by the neurons. Recent research on retinal function has substantially advanced understanding in both areas. First, visual information is transmitted to the brain by at least 17 distinct retinal ganglion cell types defined by characteristic morphology, light response properties, and central projections. These findings provide a much more accurate view of the parallel visual pathways emanating from the retina than do previous models, and they highlight the importance of identifying distinct cell types and their connectivity in other neural circuits. Second, encoding of visual information involves significant temporal structure and interactions in the spike trains of retinal neurons. The functional importance of this structure is revealed by computational analysis of encoding and decoding, an approach that may be applicable to understanding the function of other neural circuits.

Contents

INTRODUCTION.....	2
Overview	2
Scope.....	3
MANY DISTINCT PATHWAYS OF VISUAL INFORMATION EMANATE FROM THE RETINA.....	3
Background	3
Advances.....	3
Implications.....	11
PRECISION OF RETINAL SPIKE TRAINS AND MODELS OF THE NEURAL CODE.....	12
Background	12
Advances.....	12
Implications.....	15
SYNCHRONIZED FIRING AND CONSEQUENCES FOR VISUAL SIGNALING.....	15
Background	15
Advances.....	15
Implications.....	18
DECODING THE VISUAL SIGNAL FROM RETINAL SPIKE TRAINS.....	18
Background	18
Advances.....	19
Implications.....	20
CONCLUSIONS.....	21

INTRODUCTION

Overview

A central goal of neuroscience is to understand how information is processed in neural circuits. This goal poses at least two major challenges. First, one must identify the distinct cell types and connectivity in the circuit. Second, one must describe the computations performed by the neurons and how the results are represented. This review highlights recent progress on understanding the visual function of the retina, with emphasis in these two areas.

RGC: retinal ganglion cell

In the first section, Many Distinct Pathways of Visual Information Emanate from the Retina, we argue that the textbook view of three primary parallel pathways carrying visual information from retina to thalamus and cortex is grossly oversimplified. The subdivision of retinal output signals into parallel pathways with distinct physiological properties and central projections has been appreciated for decades, and its functional importance has been explored in numerous studies. However, recent findings have dramatically expanded and clarified our understanding of these parallel pathways. This expansion and clarification have major implications for understanding the function of the visual system and highlight the need for focused effort to identify the distinct functions and central projections of each retinal pathway.

In the subsequent three sections, Precision of Retinal Spike Trains and Models of the Neural Code, Synchronized Firing and Consequences for Visual Signaling, and Decoding the Visual Signal from Retinal Spike Trains, we discuss transmission of visual information from the retina to the brain and the consequent impact on decoding by downstream structures. In recent years, empirical findings have revealed that retinal spike trains are significantly more complex than was commonly appreciated, exhibiting surprisingly precise spike timing and highly structured concerted activity in different cells. Modeling efforts have been aimed at capturing the complexity of retinal ganglion cell (RGC) spike trains evoked by visual stimuli and revealing the resulting constraints on decoding in central visual structures. Progress in these areas has significant implications for understanding the function of other neural circuits.

In the concluding section, we provide a brief summary of how the progress described above clarifies our understanding of retinal function and suggest implications for future work in the retina and other areas of the nervous system.

Scope

As in any review, brevity demands focus. We focus on the topics above because they are likely to be important for understanding primate vision and because they have important parallels in other areas of neuroscience. We also focus on studies relevant to cone-mediated (daylight) vision with an emphasis on primate retina where possible, although results in other species (usually mammalian) are discussed as necessary. Numerous reviews, books, and chapters have been written on various aspects of retinal structure and function, including many important areas that are not covered here (Dacey 2000, 2004; Dowling 1987; Field et al. 2005; Lee 1996; Lukasiewicz 2005; Masland 2001; Meister & Berry 1999; Rodieck 1988, 1998; Sterling & Demb 2004; Taylor & Vaney 2003; Troy & Shou 2002; Wassle 2004; Wassle & Boycott 1991). Whenever possible, we refer to these sources for background information and a more comprehensive list of citations.

MANY DISTINCT PATHWAYS OF VISUAL INFORMATION EMANATE FROM THE RETINA

Background

Early physiological recordings from cat retina focused primarily on two functionally defined types of RGCs. One type (X) summed visual inputs approximately linearly over space and exhibited sustained changes in firing rate in response to a change in light intensity; the second type (Y) performed a more complex nonlinear computation over space and exhibited more transient responses (Cleland et al. 1971, Enroth-Cugell & Robson 1966; see Troy & Shou 2002). Anatomical work in cat retina also focused primarily on two major RGC types, termed alpha and beta (Boycott & Wassle 1974; see Sterling & Demb 2004). These two cell types corresponded to the X and Y cells, respectively, cementing the notion of two primary pathways in cat retina (Boycott & Wassle 1974, Cleland & Levick

1974a, Fukuda et al. 1984, Peichl & Wassle 1981, Saito 1983). Meanwhile, the anatomical and physiological properties of less frequently observed cell types received less attention (Cleland & Levick 1974b; see Troy & Shou 2002); some of these cell types may be homologous to cell types identified in the rabbit retina (e.g., Caldwell & Daw 1978b, Rockhill et al. 2002, Roska & Werblin 2001; see Masland 2001).

Work in primate retina followed a somewhat similar path (see Shapley & Perry 1986). A key finding was that midget and parasol RGCs (Rodieck et al. 1985, Watanabe & Rodieck 1989), which exhibit sustained and transient responses respectively (de Monasterio 1978, de Monasterio & Gouras 1975, Gouras 1968), project to the parvocellular and magnocellular layers of the LGN respectively (Perry et al. 1984). This and subsequent findings on parvocellular and magnocellular projections to the visual cortex spurred investigation of the distinctions between the two “pathways,” including different spatial resolution, response dynamics, and chromatic properties (see Merigan & Maunsell 1993, Silveira et al. 2004). The simplicity of this two-pathway model of visual processing generated great interest in its functional significance (e.g., Livingstone & Hubel 1988). For the most part, the possibility that signals from other RGC types played a significant role in primate vision was ignored [including cell types that project to the LGN (Rodieck & Watanabe 1993)], in part because the midget and parasol cells constitute a substantial majority (~70%) of the entire RGC population (Dacey 2004, Perry et al. 1984).

Advances

Small bistratified cells. A major crack in the standard picture was the discovery of a new RGC type in the primate retina, the small bistratified cell (**Figures 1, 2**), which conveys a distinctive blue-ON/yellow-OFF color signal to the brain (Calkins et al. 1998, Dacey & Lee 1994). The bistratified dendritic morphology

LGN: lateral geniculate nucleus

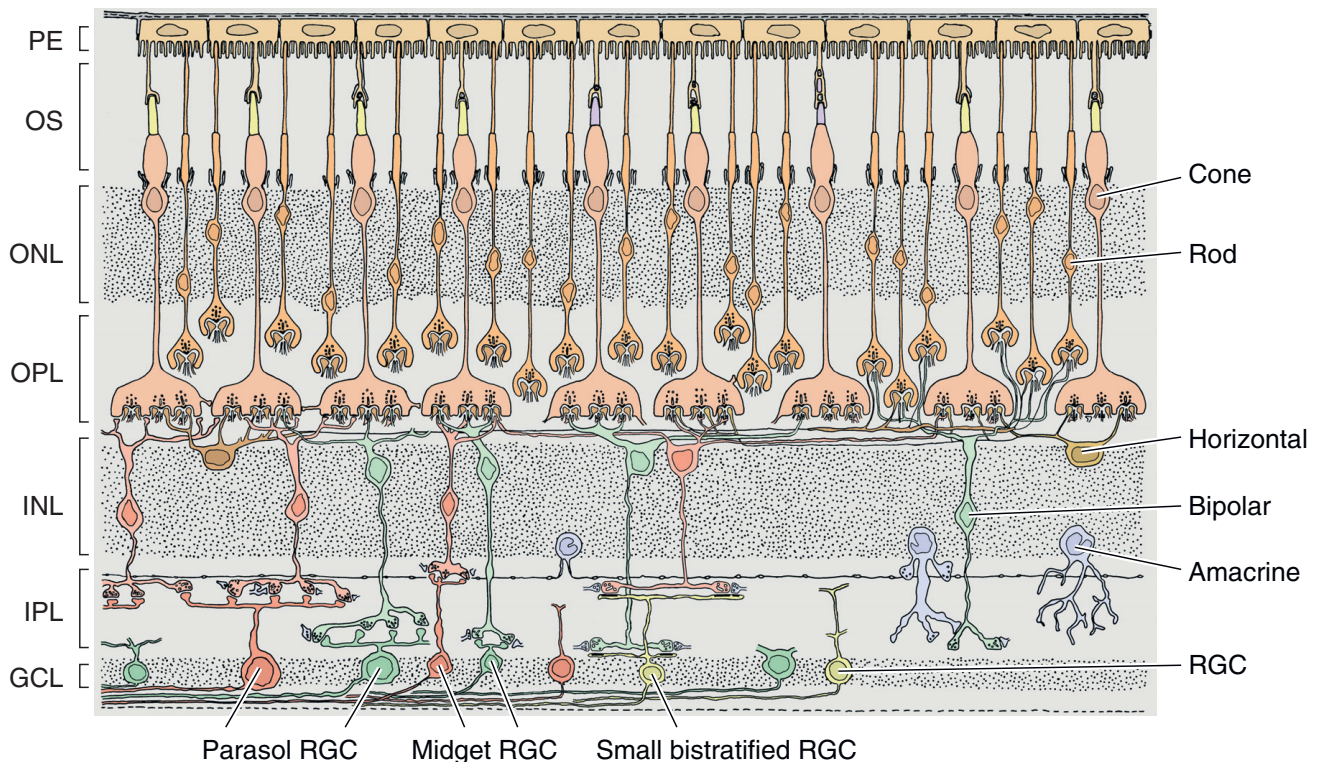

Figure 1

Schematic illustration of the primate retina in cross-section. The retinal circuit is composed of five major classes of neurons within a layered structure. Distinct layers are indicated with abbreviations (*left*): PE, pigment epithelium; OS, outer segments of photoreceptors; ONL, outer nuclear layer; OPL, outer plexiform layer; INL, inner nuclear layer; IPL, inner plexiform layer; GCL, ganglion cell layer. Rod and cone photoreceptor cells transduce light into electrical signals and synapse onto bipolar and horizontal cells. Rod photoreceptors mediate night vision; cone photoreceptors mediate daylight vision. Bipolar cells integrate and convey photoreceptor signals to retinal ganglion cells (RGCs) and amacrine cells. Horizontal cells perform lateral processing by interacting with bipolar and photoreceptor cells; amacrine cells perform lateral processing by interacting with bipolar cells and RGCs. RGCs transmit visual information, in the form of spatiotemporal patterns of action potentials, to seven major target areas in the brain: lateral geniculate nucleus, superior colliculus, pretectum, pulvinar, accessory optic system, pregeniculate nucleus, and suprachiasmatic nucleus. Of the five major cell classes, only RGCs and some amacrine cells fire action potentials; other cells represent visual information with graded potentials. Each major retinal cell class consists of multiple cell types distinguished by morphology, connectivity, and light response properties. (L)ong and (M)iddle wavelength sensitive cones are shown with yellow outer segments, and (S)hort wavelength sensitive cones are shown with blue. Bipolar cells, amacrine cells, and RGCs make cell-type specific contacts in different sublayers of the IPL, which contribute to shaping RGC light responses. In general, the processes of ON bipolar cells terminate in the inner layers of the IPL and synapse on to ON RGCs (*green*); similarly, OFF bipolar cells stratify in the outer layers and synapse on to OFF RGCs (*red*). Some RGCs stratify in more than one layer of the IPL and receive input from both ON and OFF bipolar cells (*yellow*). Five major circuits, including ON and OFF midget bipolar cells synapsing on midget RGCs, ON and OFF diffuse bipolar cells synapsing on parasol RGCs, and S cone bipolar cells synapsing on small bistratified cells are shown in detail (*left*). (*Right*) Shown are two elements of rod pathway circuitry: the synaptically connected A2 amacrine cell and rod bipolar cell. Several bipolar cells, amacrine cells, and RGCs are shown with truncated and/or disconnected processes to indicate uncertainty about their morphology and connectivity. Modified with permission from Rodieck (1988).

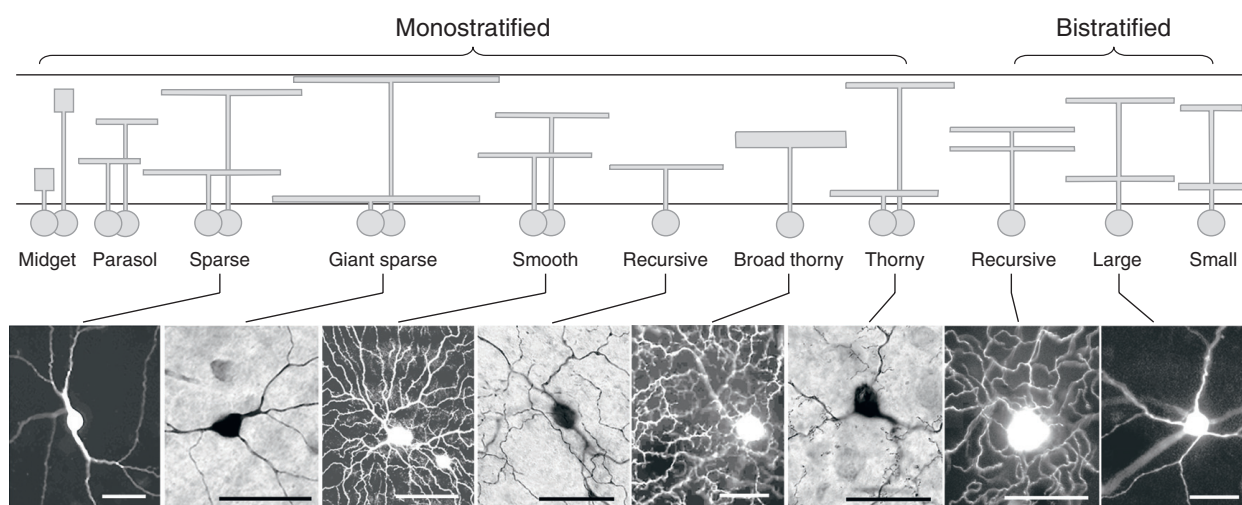

Figure 2

Parallel representations of the visual scene in at least 17 distinct types of RGCs in the primate retina (Dacey 2004). Top panel shows schematic cross-sectional representations of morphologically distinct RGC types exhibiting either monostratified or bistratified dendritic arborization in the IPL; the boundaries of the IPL are indicated schematically by horizontal lines. The vertical position of each schematic dendritic arbor indicates its characteristic stratification in the IPL; e.g., giant sparse cells stratify at either the inner (*bottom*) or outer (*top*) boundary of the IPL. The horizontal extent of each schematic dendritic arbor corresponds roughly to the relative dendritic diameter of the corresponding cell type at a given eccentricity; e.g., parasol cells and small bistratified cells at the same eccentricity have dendritic arbors of comparable size. Lower panels show top views of filled cells obtained using retrograde photostaining from rhodamine dextran injections in the LGN and superior colliculus; scale bar is 50 μm . Modified with permission from Dacey (2004).

clearly distinguished this cell type from the midget type (see **Figure 1**), which had been identified in textbooks as the carrier of color information (e.g., Mason & Kandel 1991, Zrenner et al. 1990). Subsequent findings indicated that small bistratified cells project to layers of the LGN distinct from the parvocellular and magnocellular layers, termed koniocellular layers (Martin et al. 1997, White et al. 1998). The textbook view evolved incrementally, by adding a third koniocellular “pathway” (e.g., Kaplan 2004, Reid 1999).

Multiple new RGC types. In fact, however, the discovery of the small bistratified cell probably heralds the end of the simplified view of visual pathways based on LGN laminae. Replacing the simplified view is a more nuanced view of the visual signals emanating from multiple RGC types in the retina with distinctive properties and central projections (Dacey 2004). Building on earlier

work, recent anatomical studies have revealed a plethora of RGC types in primate retina, many of which project to the LGN (**Figure 2**) (Dacey et al. 2003, 2005, Rodieck & Watanabe 1993, Yamada et al. 2005). In addition to the well-known 5 major types (ON and OFF parasol, ON and OFF midget, and small bistratified) 12 additional cell types with distinctive morphology, including 7 that project to the LGN, have been identified. Some of these may coincide with cell types previously identified as projecting to the superior colliculus and other nonthalamic structures; many RGC types project to two or more central structures (Dacey 2004). However, even if nonthalamic structures mediate primarily subconscious aspects of vision (an uncertain premise), the fact that at least 7 new cell types project to the LGN indicates that their potential role in visual perception cannot be ignored.

Note that some but not all of the known cell types may be considered as functional

pairs. For example, ON and OFF parasol cells have dendrites that stratify differently (see **Figure 1**) but otherwise exhibit similar morphology (Watanabe & Rodieck 1989), hence their common name. Within the known set of 17 cell types, if morphologically paired ON and OFF subtypes are considered to form one functional pathway, then a total of 11 distinct pathways are known (see **Figure 2**). However, the conceptual pairing of ON and OFF cells may be somewhat misleading. For example, ON and OFF parasol cells form separate mosaics and exhibit clear differences in dendritic field extent and density (Dacey & Petersen 1992), as well as in light response dynamics, spatial integration, and nonlinearity (Chichilnisky & Kalmar 2002). Furthermore, asymmetries in central visual processing of increment and decrement stimuli suggest that these differences may have functional consequences (Bowen et al. 1989, Chichilnisky & Wandell 1996, Kremers et al. 1993, Wehrhahn & Rapf 1992; see Schiller 1992). Finally, some cell types such as the small bistratified cell do not appear to have opposite-sign counterparts (**Figure 2**). These observations suggest that it may be important to consider separately the visual function of ON and OFF cells with similar morphology.

Novel visual signals. With a few exceptions, the response properties of the recently discovered RGC types are unknown. One cell type, the large bistratified cell, has a blue-ON/yellow-OFF spectral signature similar to the small bistratified cell; however, its spatial and temporal integration properties appear different (Dacey 2004). Another cell type, the giant sparse cell, has intriguing response properties (Dacey et al. 2005). As the name implies, giant sparse cells have large dendritic fields (**Figure 2**) and correspondingly large receptive fields. They are intrinsically light sensitive, expressing the photopigment melanopsin, a recently discovered property of a small fraction of RGCs (Berson et al. 2002). This results in a light response that is independent of rod and cone inputs and is sev-

eral orders of magnitude slower. Similar cells have been observed in rodent retinas; these cells typically project to the suprachiasmatic nucleus and pretectal olivary nucleus and are thought to modulate circadian rhythms and pupil size (Hattar et al. 2002, 2003). In primate, the giant sparse cells also project to LGN and exhibit a yellow-ON/blue-OFF spectral signature obtained by opposing input from S cone signals and L and M cone signals in addition to their intrinsic light sensitivity (Dacey et al. 2005).

These surprising properties hint at the possibility that novel visual signals are conveyed by the nine or more cell types that have not been characterized physiologically. For example, two different types of direction-selective RGCs have been observed in cat and in several rodent species (Barlow & Hill 1963, Cleland & Levick 1974b, Weng et al. 2005) and have likely morphological homologs in primate retina (Dacey et al. 2003, Yamada et al. 2005) with as yet untested physiological properties. Also, recordings from a new large cell type in primate retina (Petrusca et al. 2005) revealed nonlinear summation properties similar to those observed in Y cells in other species (Caldwell & Daw 1978b, Demb et al. 1999, Enroth-Cugell & Robson 1966). Indeed, the more complete picture of RGC types in primate retina broadly resembles the known diversity of RGC types in rabbit and cat retina (see Masland 2001, Troy & Shou 2002). However, the newly discovered cell types in primate retina exhibit relatively large dendritic fields (see **Figure 2**) and corresponding low density: Each comprises roughly 1%–2% of the entire RGC population, compared with roughly 80% for the midget, parasol, and small bistratified cells combined (Dacey 2004, Dacey & Petersen 1992, Perry et al. 1984). This discrepancy in density may be a major reason that RGC diversity was previously underappreciated.

Intra-retinal origins of diverse visual pathways. Several observations indicate that the distinctive light response properties of

different RGC types are created largely by dedicated presynaptic circuitry in the retina. Bipolar cells, amacrine cells, and RGCs form synaptic contacts in the inner plexiform layer (IPL) with exquisite laminar and cell-type specificity (see **Figure 1**) (Boycott & Wässle 1991, MacNeil et al. 1999, Watanabe & Rodieck 1989; see Masland 2001, Wässle 2004). Likewise, photoreceptors and horizontal and bipolar cells form cell-type specific contacts in the outer plexiform layer (OPL), which exhibit laminar organization (see **Figure 1**) (Haverkamp et al. 2000; see Sterling & Demb 2004, Wässle 2004). Additional observations also suggest a diverse and intricate arrangement of circuits dedicated to distinct visual computations:

- Bipolar cells appear to initiate many of the major parallel pathways: Quantitative morphological analysis indicates that there are at least 10 distinct bipolar cell types in mammals (Boycott & Wässle 1991, Cohen & Sterling 1990, Ghosh et al. 2004; see Wässle 2004). Nine of these types are cone driven, and each cone probably drives at least one representative of nearly every type (Grunert et al. 1994). This finding implies that at the first synapse in the retina, cone signals diverge into many bipolar pathways, at least some of which exhibit molecularly distinct postsynaptic processing (DeVries 2000, DeVries et al. 2006, Haverkamp et al. 2000). Furthermore, most bipolar cell types synapse onto distinct RGC types, which implies that the diversity of pathways is preserved in RGCs (Calkins et al. 1994, 1998; Jacoby et al. 2000; Kolb & Dekorver 1991; Kolb & Marshak 2003; Kouyama & Marshak 1992; McGuire et al. 1984, 1986; Schein et al. 2004).
- Amacrine cells, which interact with bipolar cells and RGCs, appear to be the most diverse class of retinal interneurons: At least 30 distinct mammalian

amacrine cell types have been identified (MacNeil et al. 1999). The function of most amacrine cell types is poorly understood (see Masland 2001). However, several factors suggest that their contribution to information processing is important. Cumulatively, amacrine cells appear to provide the greatest number of synapses to at least some types of RGCs (Bordt et al. 2006, Ghosh & Grunert 1999, Marshak et al. 2002) and express a stunning diversity of neurotransmitters (see Kolb 1997, Masland 2001, Wässle 2004). In addition, anatomical studies suggest specificity of inputs from distinct types of amacrine cells to distinct types of RGCs (Bordt et al. 2006, Dacey 1993a, Dacey & Brace 1992, Zhang et al. 2005). These factors make them ideal candidates for shaping the more complex aspects of RGC light responses (Caldwell et al. 1978, Caldwell & Daw 1978a, Daw & Ariel 1981, Dong & Werblin 1998, Frishman & Linsenmeier 1982, Jacobs & Werblin 1998; see Lukasiewicz 2005). For example, some amacrine cell types are important for shaping the kinetics of RGC light responses (McMahon et al. 2004, Nirenberg & Meister 1997). Also, starburst amacrine cells play a crucial role in shaping responses of ON-OFF direction-selective RGCs in rodent retinas (see Taylor & Vaney 2003); similar cells have been observed in the primate retina (Yamada et al. 2003). Finally, some amacrine cells distribute their synaptic outputs over long distances, suggesting they may contribute to nonclassical receptive field properties (e.g., Barlow et al. 1977, Frishman & Linsenmeier 1982, McIlwain 1964, Olveczky et al. 2003, Roska & Werblin 2003) or to driving collections of RGCs simultaneously when stimuli span a large retinal area (see Synchronized Firing and Consequences for Visual Signaling).

IPL: inner plexiform layer

OPL: outer plexiform layer

- Photoreceptors and horizontal cells are relatively simple populations compared with bipolar and amacrine cells. In some primate species including humans, three different types of cone photoreceptors have been identified on the basis of their distinct spectral sensitivity (Baylor et al. 1987), but each spectral type appears to be homogeneous. The apparent functional role of this receptor diversity is to expand the range of wavelengths that can be encoded and provide the foundation for color vision (see Gouras 1991). Rod photoreceptors are thought to be a homogeneous population, exhibiting exquisite sensitivity required for vision in dim illumination such as starlight (see Field et al. 2005). Apparently only two distinct types of horizontal cells exist in mammals (Dacey et al. 1996, Wassle et al. 2000). Their primary function may be to produce center-surround antagonism, which is the best-known feature of the retinal output (Mangel 1991, Verweij et al. 2003).

Interpretation of diversity in retinal circuits.

The above anatomical evidence indicates that the retina represents the visual scene using at least 17 distinct RGC types with distinct projections to the brain. Furthermore, the evidence strongly suggests that each RGC type is subserved by distinct presynaptic circuitry, composed of a morphologically and molecularly distinct set of amacrine, bipolar, horizontal, and photoreceptor cells with specific connectivity. Does the great diversity of intraretinal circuits and central projections have a major impact on our understanding of the visual pathways? Because relatively little is known about most of the newly identified RGC types (except by tentative cross-species homology), this question cannot be answered fully without further investigation. However, it is worth considering how three possible misinterpretations of the observed cell-

type diversity can lead to underestimating its importance:

- *Perhaps fine-grained morphological distinctions, which are difficult to quantify, do not actually indicate the existence of a distinct cell type, but instead reflect random diversity.* If true, the increasingly fine-grained morphological distinctions could amount to splitting hairs, and the standard three-pathway description (midget → parvocellular; parasol → magnocellular; small bistratified → koniocellular) may be more useful for understanding visual function. In recent years this concern has been addressed with the identification of two robust criteria for morphological classification. First, studies of RGC morphology over large regions of retina showed that when the retinal eccentricity of each cell is taken into account, cell types with distinct morphological characteristics fall into unambiguous clusters on the basis of quantitative measurements such as dendritic field extent (Dacey et al. 2003, Dacey & Petersen 1992, Rodieck & Watanabe 1993, Rodieck et al. 1985, Watanabe & Rodieck 1989). Analysis as a function of eccentricity is important because substantial variation of morphology with eccentricity can otherwise obscure distinctions between cell types. Furthermore, distinct bipolar, amacrine, and RGC types have processes that stratify in distinct sublayers of the IPL (**Figures 1, 2**) (see Masland 2001, Wassle 2004). Thus, when analyzed correctly, morphological distinctions do not reflect increasingly detailed subdivisions of a uniform population, but a fundamental aspect of the biology. Second, in each morphologically defined cell type examined to date, somas over a region of retina are regularly spaced, and dendritic fields collectively cover the retina uniformly and with constant overlap (in some cases

no overlap) (Dacey 1993a,b; Dacey & Brace 1992; Wässle et al. 1981a,b,c). This coordinated mosaic arrangement is thought to create a regular sampling of the visual field, as evidenced by the strikingly regular organization of receptive fields in each identified cell type (see **Figure 3**) (Chichilnisky & Kalmar 2002, DeVries & Baylor 1997, Shlens et al. 2006). However, cells of different types display no obvious spatial relationship (Eglen et al. 2005, Rockhill

et al. 2000, Wässle et al. 1983). Importantly, mosaic organization also implies that each cell type is irreducible: Subsets of each type of cell do not cover the entire visual field. Together, these observations provide compelling evidence that morphologically distinct cell types constitute the fundamental unit of retinal organization.

- *Perhaps only functional distinctions between groups of cells, rather than morphological distinctions, should influence how we think*

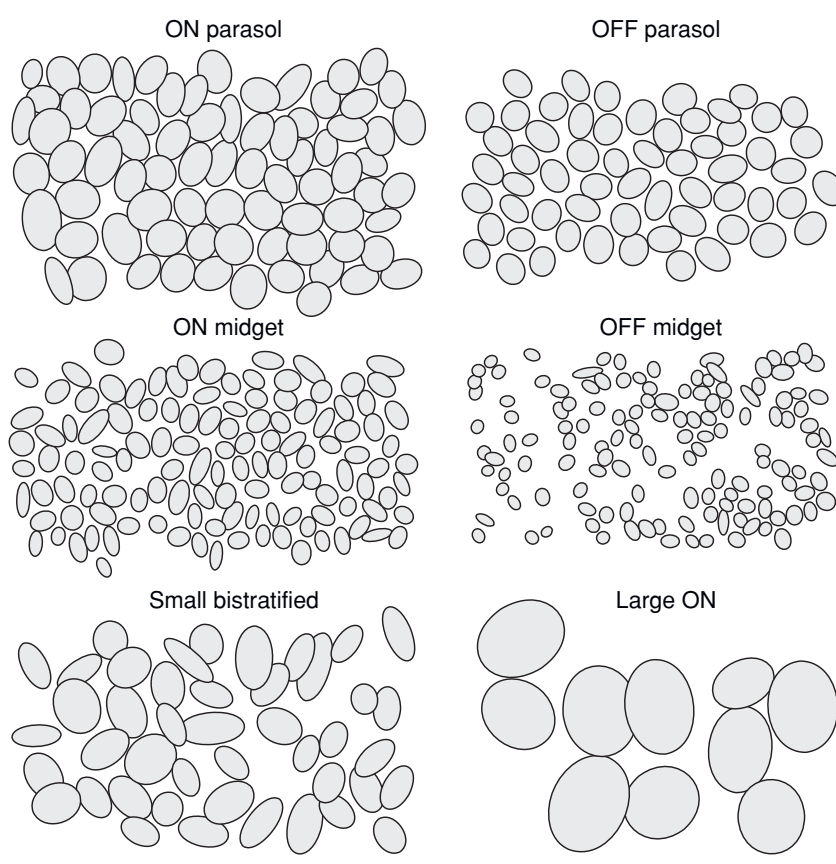

Figure 3

Receptive field mosaics of five identified RGC types and one unknown cell type in primate retina. Each panel shows the receptive field outlines of a collection of cells obtained in a single 512-electrode recording from isolated peripheral primate retina (E.J. Chichilnisky & A.M. Litke, unpublished data). Each ellipse shows the 1.3 SD contour of a Gaussian fit to the receptive field of a single cell. Different panels show data from different recordings. In each recording, distinct cell types were segregated by quantitative clustering on the basis of receptive field diameter and response kinetics. ON and OFF parasol, ON and OFF midget, and small bistratified cells were identified by comparison with published reports of receptive field and dendritic field size and chromatic sensitivity (Chichilnisky & Kalmar 2002). Large ON cells form a mosaic, confirming that they represent a single cell type; however, the morphological identity is unknown. Missing cells in each mosaic probably reflect experimental undersampling rather than gaps in the retinal representation (DeVries & Baylor 1997, Wässle et al. 1981b). Scale bar = 1 mm.

about visual pathways (Segev et al. 2006). This view is equivalent to assuming that unambiguous morphological distinctions between cell types in some cases may have no functional correlates. The exquisite laminar organization, cell-type specific connectivity, and mosaic arrangement of retinal neurons certainly suggest otherwise (see Dacey 2004, Masland 2001, Sterling & Demb 2004, Taylor & Vaney 2003, Troy & Shou 2002). Indeed, in each mammalian retina that has been examined, distinct morphology of RGCs corresponds with distinct central projection patterns and physiological properties. An important methodological consideration is that physiological recordings may fail to reveal real functional distinctions between cell types because of large variability attributable to visual field location and the physiological state of the animal or preparation or because of a restricted choice of stimuli. Consider, for example, the recent observation that on and off primate parasol cells recorded simultaneously exhibit systematic differences in receptive field size, response dynamics, and response nonlinearity (Chichilnisky & Kalmar 2002). These differences were not observed in many quantitative studies using single-unit recordings (e.g., Benardete & Kaplan 1997, 1999; Kremers et al. 1993), presumably because they were masked by other sources of variability. In general, reliable physiological identification of many cell types probably requires multineuron recordings combined with extensive stimulus manipulations (DeVries & Baylor 1997, Grivich et al. 2005). Furthermore, morphological measurements can sometimes reveal cell-type distinctions more clearly than can physiological measurements. For example, the dendritic field size difference between on and off parasol cells, which presumably underlies the

receptive field size difference, was observed years earlier (Dacey & Brace 1992). Thus, morphological distinctions between cell types in the retina are very likely to reflect functional distinctions.

- *Perhaps the numerical dominance of neurons projecting to the three well-known LGN-defined "pathways" indicates that the additional retinal cell types are not of great importance for visual function.* The numerical dominance of the well-known cell types is consistent with their small receptive field size: Assuming that all cell types tile the visual scene with comparable coverage (see **Figure 3**) (DeVries & Baylor 1997), cells with larger receptive fields will be less numerous. Thus, cell number may be a reasonable proxy for spatial sampling density, but perhaps little else. Does coarse spatial sampling indicate that a cell type is unimportant? Probably not. Although midget, parasol, and small bistratified cells constitute ~80% of RGCs in primate retina, the remaining cells number ~200,000, more than the total number of RGCs in the cat retina. Furthermore, consider the relative importance of subpopulations of non-RGC cell types. The S cones constitute no more than 10% of the entire cone population; yet without these cells no blue/yellow color perception would be possible. Indeed, cone photoreceptors overall are outnumbered ~20 to 1 by rod photoreceptors. Yet without cones, no daylight vision would be possible. Other examples of small but important cell populations abound in the nervous system. For example, the number of neurons in the suprachiasmatic nucleus, the apparent master of circadian rhythms, is ~10,000 (Hofman et al. 1996). The recently identified melanopsin-containing RGCs, which may form the primary retinal projection to the suprachiasmatic nucleus,

constitute only ~0.2% of all RGCs in primates (Dacey et al. 2005). Yet disruption of circadian rhythms is debilitating. In summary, it seems unlikely that numerically small populations of cells can be safely ignored in the interest of providing a simpler summary of the visual pathways.

Implications

In summary, at the photoreceptor synapse multiple visual signals begin to diverge. These signals are processed by increasingly diverse circuitry before converging on at least 17 distinct types of RGCs. Each RGC type covers the visual field with striking regularity and represents the output of a single elementary retinal circuit. This circuit diversity has profound implications for understanding the function of the visual system. Furthermore, recent studies reveal a similar diversity of cell types and connectivity in other nervous system structures, suggesting broader implications for understanding brain function.

Retina. Focused effort and new tools are required to study the many pathways emerging from the retina. Many years of study have resulted in adequate characterizations of the most easily recorded RGC types. However, new labeling and recording techniques will probably be required to advance our understanding of the remaining, less numerous RGC types as well as the many interneuron types. Important challenges include identifying the distinct subcircuits that terminate on each RGC type, identifying the diversity of amacrine cell function and its contribution to shaping RGC responses, and identifying how RGCs within and across mosaics interact in communicating visual information to the brain (see Synchronized Firing and Consequences for Visual Signaling).

Central visual system. Textbook descriptions of the visual system as composed of three LGN-defined “pathways” (magnocel-

lular, parvocellular, koniocellular) are grossly oversimplified. In addition to the fact that retinal pathways are more numerous and complex, recent work in the LGN reveals important departures from the standard model. First, two studies have suggested that the magnocellular layers are composed of more than one cell type (Kaplan & Shapley 1982, Xu et al. 2001), perhaps indicative of non-parasol projections. Second, several studies indicate that koniocellular layers are composed of multiple cell types (Hendry & Reid 2000, Van Hooser et al. 2003, White et al. 2001, Xu et al. 2001): Dorsal layers contain cells with large receptive fields; ventral layers contain cells with physiological properties similar to cells projecting to the superior colliculus and pretectum; and central layers carry blue-ON/yellow-OFF signals. These findings suggest that the three-pathway model fails to capture the functional diversity in the LGN. Furthermore, the specificity of connections from LGN to primary visual cortex extends beyond the well-known magnocellular/parvocellular separation (Chatterjee & Callaway 2003, Xu et al. 2001; see Callaway 2005, Hendry & Reid 2000). Thus visual signals emanating from multiple distinct RGC types may remain segregated in the cortex.

Cell-type organization in the brain. Central structures may also exhibit complexity and coordination that arise from previously underappreciated cell-type diversity. This idea is at odds with a theory of cortical organization in which the functional unit is a column or a layer within a column, and fine distinctions between cells within this functional unit are random or unimportant. Indeed, it is possible that the functional organization of cortex is fundamentally different from that of the retina. However, this is by no means proven. Furthermore, historically, our understanding of the cortex has lagged behind that of the retina because the retina is much more accessible to experimentation. Several decades ago, the prevailing view of retinal

organization was broadly similar to the present prevailing view of cortical organization: It was based on knowledge of a few easily distinguished cell types and the hope that this description was mostly sufficient for understanding visual processing (e.g., Kaplan & Shapley 1986, Livingstone & Hubel 1988, Merigan & Maunsell 1993, Shapley & Perry 1986). In recent years, this simplified view has given way to a more accurate picture of retinal signals. Some evidence demonstrates that a similar change in perspective may be valuable for understanding the function of the cortex, with numerous studies revealing a diverse array of distinct cell types, particularly among inhibitory interneurons, and specificity of functional connections (see Callaway 2002, 2004; Kawaguchi & Kondo 2002; Somogyi & Klausberger 2005). As new techniques are developed and applied to understanding microcircuits in the cortex, a very different picture of its functional organization may emerge.

PRECISION OF RETINAL SPIKE TRAINS AND MODELS OF THE NEURAL CODE

Background

In early quantitative studies of retinal function, a standard assumption about the neural code was adopted: RGCs communicate visual information in their time-varying firing rate (Adrian 1928). This assumption, combined with linear models of the dependence of firing rate on the visual stimulus, gave rise to the first highly successful quantitative models of RGC function (Enroth-Cugell & Robson 1966). Two major benefits of this framework were (a) a clear mathematical methodology for summarizing the response properties of RGCs, and (b) the identification of important nonlinearities in spatial and temporal summation in certain cell types (Hochstein & Shapley 1976, Kaplan & Shapley 1982, Lee et al. 1989, Shapley & Victor 1978). However, the firing rate hypothesis was not subjected to intense

experimental scrutiny until more recently (see Meister & Berry 1999, Victor 1999).

Advances

Precision of retinal spike trains. Several recent studies have shown that the temporal structure of RGC spike trains elicited by strong stimuli exhibits surprising precision, with variability in the timing of spikes in response to repeated stimulus presentations as low as ~ 1 ms (**Figure 4**) (Berry et al. 1997, Reich et al. 1997, Uzzell & Chichilnisky 2004). By itself, this observation does not prove that firing rate is an inadequate description, but at a minimum it indicates that firing rate modulates much more rapidly than the 10–100 ms time scales commonly assumed. On time scales of 1–10 ms only a few spikes are transmitted, which suggests that firing rate may not capture the essential temporal structure of retinal signals (Rieke et al. 1997).

Non-Poisson structure in spike trains. More decisively, several studies have shown that the variability of firing in response to repeated stimulus presentations is much lower than would be expected from a pure firing rate signal, on the basis of the following logic. The standard firing rate assumption is that there is a stimulus-dependent rate of spikes in any given time window after a stimulus, independent of the occurrence of preceding spikes. In this case, spike counts in any given time window must follow a Poisson distribution, which has the property that the variance is equal to the mean (see Victor 1999, Rieke et al. 1997). Several studies have shown that, in fact, spike count variance is much lower than the mean, sometimes approaching the minimum possible variance that can be obtained with discrete spike counts (see **Figure 4**) (Berry et al. 1997, Reich et al. 1997, Troy & Robson 1992, Uzzell & Chichilnisky 2004). Thus, real retinal spike trains are much less variable than would be predicted of a Poisson process, rejecting the firing rate hypothesis. In addition, another study developed a novel analysis that revealed

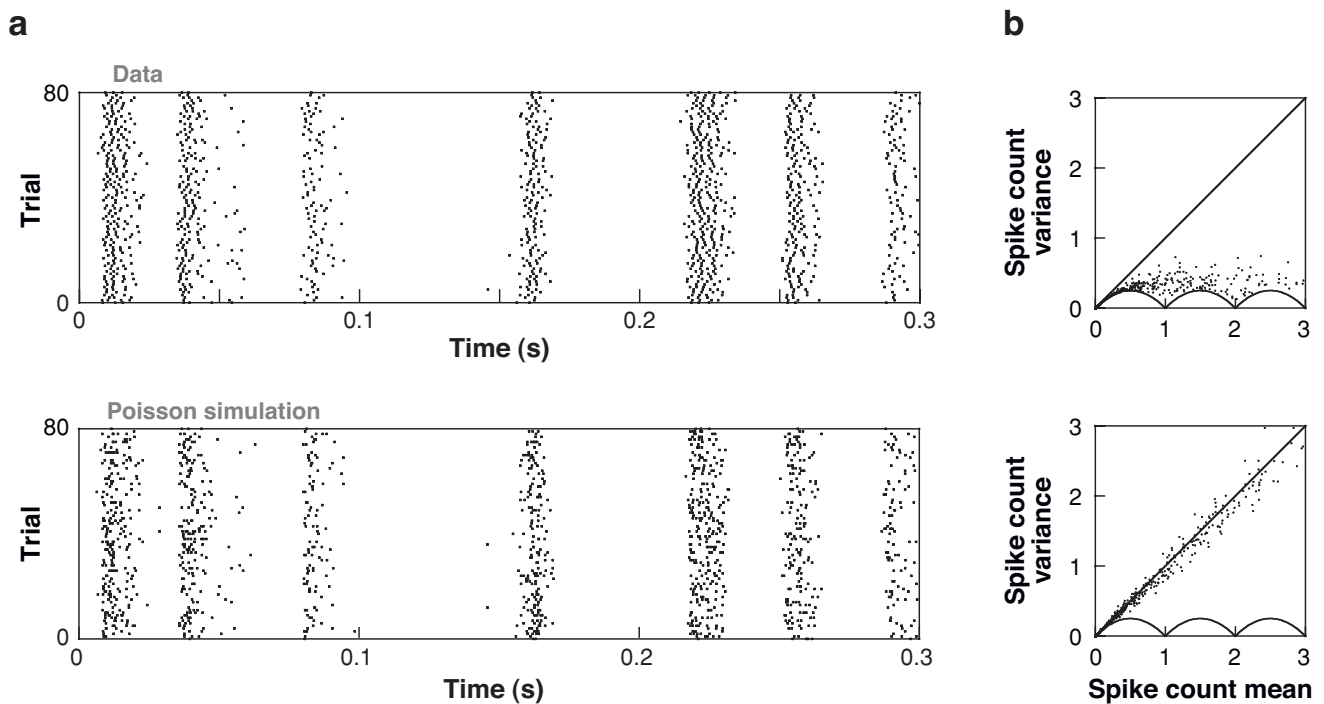

Figure 4

Reproducibility of RGC spiking in primate retina and departure from Poisson statistics. *A*: Rasters of responses to repeated presentations of a spatially uniform stimulus, the intensity of which assumed one of two randomly selected values over time, identical on every trial. The top panel shows data recorded from a single on parasol cell in primate retina (Uzzell & Chichilnisky 2004). The bottom panel shows simulated responses with the same time-varying firing rate as the data but with spikes generated according to a Poisson process. Each point indicates the time of occurrence of a spike. Vertical bands in the raster reflect the reproducibility of the response. *B*: Mean-variance relationship for data and simulation. The top panel shows the mean and variance of spike counts in 10 ms time bins for the cell from *A*; the variance in spike counts is much lower than the mean and approaches the minimum possible value associated with discrete spike counts (*scalloped lines*). The bottom panel shows corresponding values from the Poisson simulation; as expected, the variance is approximately equal to the mean. Modified with permission from Uzzell & Chichilnisky (2004).

that rate-modulated renewal processes, which are generalizations of a Poisson process, also fail to describe the temporal structure of spike trains (Reich et al. 1998; but see Troy & Lee 1994, Troy & Robson 1992).

The non-Poisson timing structure in RGC spike trains might not be very important if it had little effect on visual signaling. However, at least two studies have exploited decoding approaches (see Decoding the Visual Signal from Retinal Spike Trains) to show that the intrinsic structure of RGC spike trains contains significant information about the visual stimulus (Frechette et al. 2005, Pillow et al.

2005b). Clearly, a more sophisticated model of the neural code of the retina is needed.

Refractoriness. One important contributor to the intrinsic structure of spike trains is action potential refractoriness, which reduces the probability of firing for several milliseconds after a spike irrespective of the stimulus, inconsistent with the firing rate hypothesis. To test whether refractoriness alone is sufficient to explain the intrinsic structure of RGC spike trains, one study empirically expressed the probability of a spike at a given point in time as the product of an arbitrary “free” firing

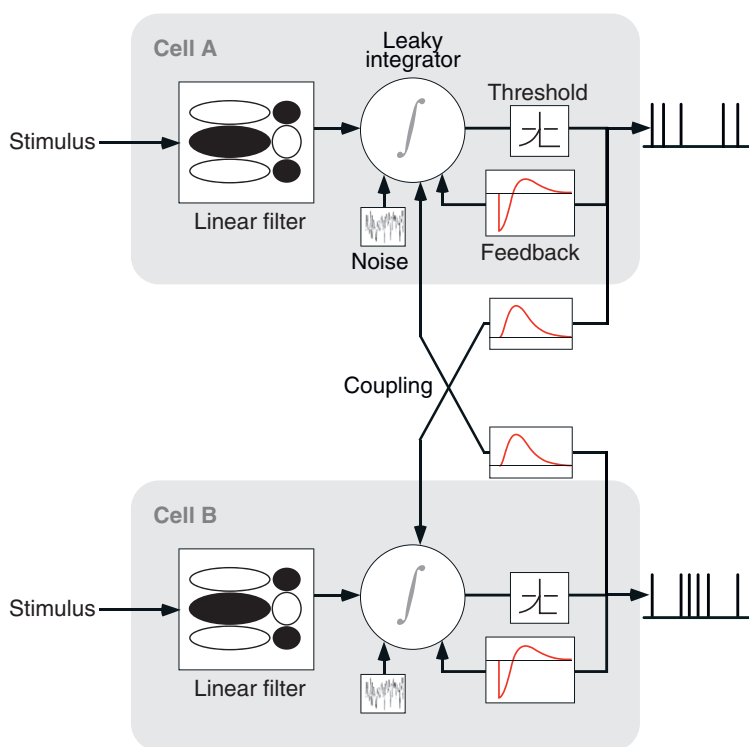

Figure 5

Schematic of leaky integrate-and-fire model of light responses in primate RGCs (Pillow et al. 2005b). The model summarizes the transformation from arbitrary time-varying stimuli to neural response in two model RGCs. For each model RGC, the contrast in the stimulus is integrated across the receptive field, using a spatiotemporal linear filter. This produces a driving current, which sums with intrinsic noise, and is accumulated by a leaky integrator to drive spiking according to a fixed threshold. Each spike produces a feedback current with a fixed temporal waveform, which sums with the stimulus-induced current and noise, introducing non-Poisson structure in the spike train. Neighboring cells interact via spike-induced coupling currents with a fixed temporal waveform.

rate multiplied by the estimated effect of absolute and relative refractoriness over time after a spike (Berry & Meister 1998). This model explained much of the timing precision and count variability in RGC spike trains, holding promise that a fairly simple modification to the Poisson hypothesis could explain the neural code (Berry & Meister 1998, Uzzell & Chichilnisky 2004). However, this model has the major drawback that the free firing rate is an arbitrary function of time, with no specified relationship to the stimulus. A full understanding of the neural code of the retina requires a model that incorporates responses to light.

LIF: leaky integrate-and-fire

Models of the neural code. Recently, a formal model was proposed that provided an accurate account of stimulus-elicited spike train structure with a plausible mechanistic basis (Keat et al. 2001). In the model, the stimulus is weighted and summed over space and time to produce an internal signal, which generates spikes by crossing a threshold. Nonlinear feedback following each spike, combined with two noise sources, allowed the model to produce a much more accurate account of both spike timing and count precision in salamander, rabbit, and cat RGCs than did Poisson models. A related model based on leaky integrate-and-fire (LIF) spike generation (Jolivet et al. 2004; Reich et al. 1997, 1998), combined with nonlinear feedback from each spike and a single noise source, reproduced spike trains in primate parasol cells with high fidelity (Figure 5) (Paninski et al. 2004, Pillow et al. 2005b). The latter model also provided valuable insight into how RGC signals can be efficiently decoded by downstream structures (see Decoding the Visual Signal from Retinal Spike Trains). The empirical success of these models suggests that a compact description of the visual signal in some RGC types is within reach. It is difficult to know how well these models will generalize to other cell types, but at a minimum, future models will require extensions to account for nonlinear spatial summation (see Many Distinct Pathways of Visual Information Emanate from the Retina) (Enroth-Cugell & Robson 1966, Hochstein & Shapley 1976, Kaplan & Shapley 1982).

Mechanistic interpretation. These models provide useful intuitions about how elementary components of neural circuits can combine to produce the observed spike train structure and precision (see Figure 5). The thresholding nonlinearity can be interpreted as representing spike generation, although it may also subsume the effects of rectification at the bipolar-RGC synapse. Spike-dependent feedback plays a central role by introducing history dependence in the spike train. These elements are separated from the initial

linear integration of the stimulus over space and time (the receptive field), which represents the essential visual computation performed by the circuit and provides a simple quantitative indication of the stimulus features that drive the cell. Additive subthreshold noise governs the timing precision and reliability of the response. Although the elements of these models may or may not correspond to biological mechanisms, they do provide hints.

Implications

Many common biophysical phenomena, such as refractoriness, bursting, spike frequency adaptation, and oscillation, give rise to intrinsic temporal structure in spike trains. Thus, to understand how neural circuits process and represent information generally requires measurements and models that go beyond descriptions of firing rate. Recent models that account for the temporal structure of RGC spike trains also show considerable promise for understanding neural signaling in other structures (Jolivet et al. 2004, Trucolo et al. 2005). The key to the success of these models is that they separate the integration of inputs over space and time, which is assumed to be linear, from the more complex aspects of spike generation. Some of these models also have tractable and robust fitting procedures and parameterization (Paninski 2004, Paninski et al. 2004), features that are conceptually secondary but have substantial practical implications. At a minimum, such models will allow a more clear understanding of how information is encoded in spike trains than was previously possible. They may also suggest testable hypotheses about the underlying mechanisms.

SYNCHRONIZED FIRING AND CONSEQUENCES FOR VISUAL SIGNALING

Background

Essential visual functions—e.g., sensing movement, identifying objects—rely on the

simultaneous activity of many RGCs. However, most of what is known about RGC light responses comes from single-unit recordings. The implicit assumption is that RGCs transmit information independently of one another (see Meister & Berry 1999, Usrey & Reid 1999). This hypothesis was challenged more than two decades ago in experiments that revealed substantial synchronized firing in cat RGCs (Mastrorade 1983). For example, two neighboring ON Y RGCs fired spontaneously within 5 ms of one another, more than twice as frequently as expected by chance. This synchronized firing is highly regular, spatially localized, and dependent on cell type. It appears to be mediated by a combination of mechanisms: direct gap junction coupling between neighboring RGCs, gap junction coupling through intermediate amacrine cells, and chemical synapses providing common input from bipolar or amacrine cells (Brivanlou et al. 1998, Dacey & Brace 1992, DeVries 1999, Hidaka et al. 2004, Hu & Bloomfield 2003, Jacoby et al. 1996, Mastrorade 1983, Schubert et al. 2005, Volgyi et al. 2005). Synchronized spikes in RGCs could cause depolarization in a shared postsynaptic target to exceed spike threshold, resulting in preferential transmission and thus influencing the visual signal conveyed to the brain (e.g., Kara & Reid 2003, Usrey et al. 1998). However, only recently have the consequences of synchrony for retinal encoding of the visual scene come under close scrutiny.

Advances

Visual messages encoded by synchrony.

Using multineuron recordings in the presence of visual stimuli, recent studies have suggested that synchronized firing in groups of RGCs may represent a distinct visual message transmitted from retina to brain (Amthor et al. 2005, Meister et al. 1995, Neuenschwander et al. 1999). For example, synchronized firing in two or more RGCs, perhaps created by simultaneous excitatory input from an amacrine cell with a small receptive field, could be used

to transmit information about fine spatial detail that is not contained in the activity of any single RGC (Meister et al. 1995). This signaling approach could allow the retina to multiplex visual messages efficiently on a small number of optic nerve fibers (Meister 1996). Because large collections of cells can fire synchronously (Schnitzer & Meister 2003), such messages may be detectable experimentally only by recording from many cells simultaneously (see **Figure 6b**).

To date, however, no direct evidence indicates a multiplexed signaling strategy. Instead, one recent study using information theoretic analysis revealed substantial redundancy in the ensemble activity of RGCs (Puchalla et al. 2005), such as might be produced by noisy common input or reciprocal excitation. Note, however, that information-theoretic analysis does not exclude the possibility that multiplexed codes coexist with common noise. Another study using a different analytical approach suggested that the importance of RGC synchrony on downstream decoding of visual signals could be small (Nirenberg et al. 2001; see Latham & Nirenberg 2005, Schneidman et al. 2003a,b).

Underlying functional connectivity. A complementary approach is to test whether synchronized firing can be understood on the basis of simple functional connectivity. Two recent studies (Schneidman et al. 2006, Shlens et al. 2006) exploited a novel maximum entropy technique to analyze spike trains recorded from multiple RGCs simultaneously (see Schneidman et al. 2003a,b). This technique makes it possible to test whether the patterns of activity in a large collection of cells can be explained by a more limited set of measured interactions, such as the synchrony between pairs of cells in the collection. To a large degree, synchronized firing among multiple RGCs was explained by pairwise functional connectivity, consistent with reciprocal excitation between cells or common input restricted to two cells, as opposed to more complex connections linking larger

cell groups. One study further showed that propagating signals can explain synchrony in nonadjacent cells, suggesting that pairwise connectivity is restricted to neighbors in a mosaic (Shlens et al. 2006). Although the mechanistic interpretation of these studies is uncertain, the results suggest that much of the visual signal can be understood on the basis of single-unit properties and neighbor-neighbor interactions, rather than via more elaborate multiplexed codes. These findings also suggest the possibility that retinal population activity can be understood using relatively simple models, by greatly reducing the types of interactions that need to be explained. For example, the results suggest that extensions of the LIF model to account for multicell activity need only incorporate pairwise connections rather than connections between larger groups of cells (see below and **Figure 5**).

However, specific stimuli not tested in these experiments, such as stimuli with extended spatial structure, could induce interactions in larger groups of cells, perhaps via the action of large-field amacrine cells (see Ackert et al. 2006, Amthor et al. 2005, Barlow et al. 1977, Demb et al. 1999, McIlwain 1964, Neuenschwander & Singer 1996, Olveczky et al. 2003, Passaglia et al. 2001, Roska & Werblin 2003). Another caveat is that maximum entropy analysis may not reveal small departures from pairwise interactions (Shlens et al. 2006). Therefore, some uncertainty remains about whether synchronized firing in RGCs represents an entirely new visual signal transmitted via multiplexed firing patterns, or simple reciprocal connectivity, or some combination of the two.

Models of circuit origin and impact on visual signals. As with the statistics of firing in individual neurons (see Precision of Retinal Spike Trains and Models of the Neural Code), a full understanding of synchrony will require a quantitative model that can reproduce the observed patterns of activity in many cells in response to light. One promising development is that an extension of the LIF

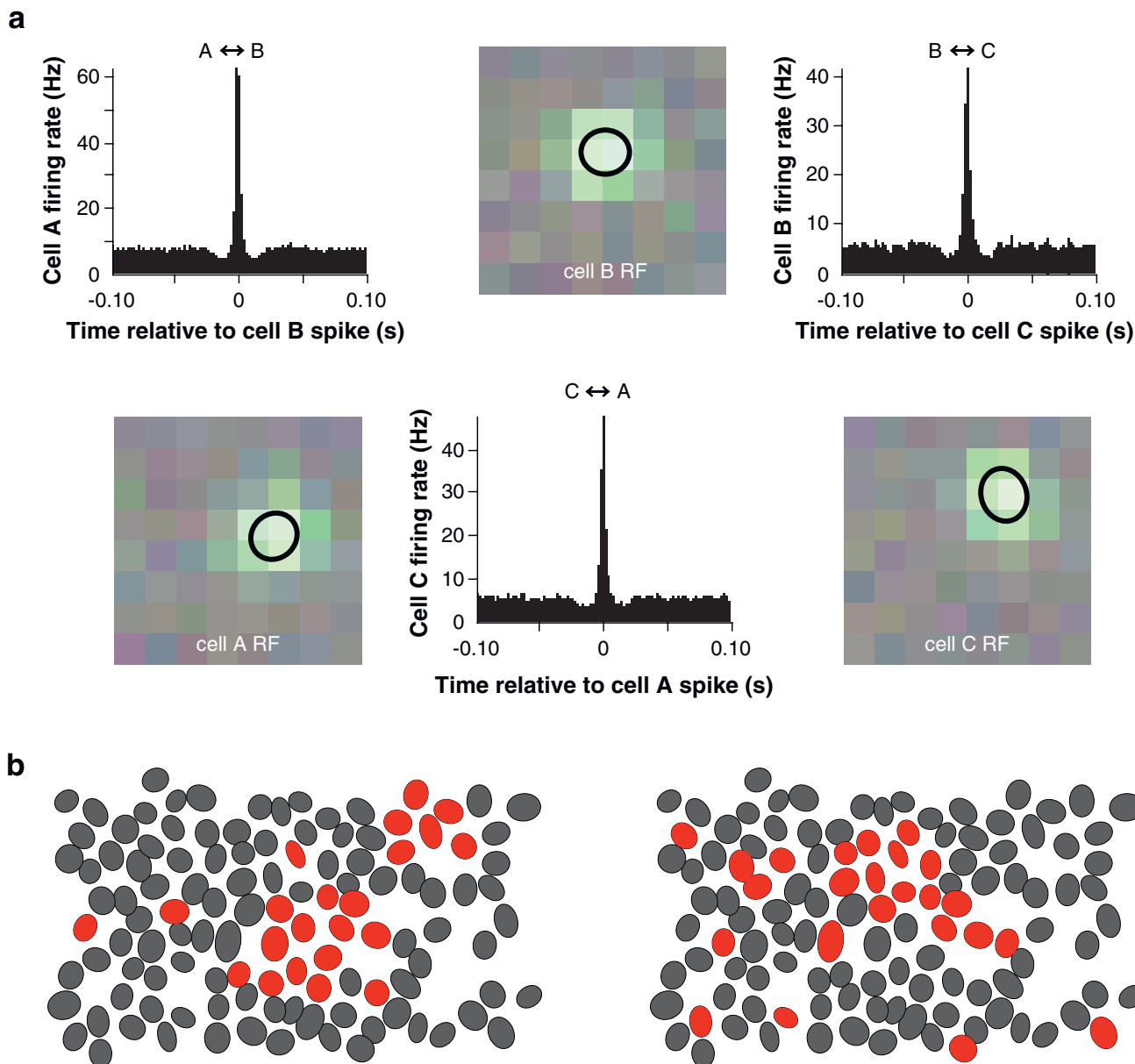

Figure 6

Synchronized firing in primate RGCs. *A*: Images show receptive fields of three neighboring primate ON parasol RGCs measured simultaneously using multielectrode recordings and reverse correlation (E.J. Chichilnisky & D.A. Baylor, unpublished data); black ovals indicate Gaussian fit to the spatial sensitivity profile of each cell (Chichilnisky & Kalmar 2002). Graphs show cross-correlation functions obtained from each pair of cells recorded in the presence of constant, spatially uniform illumination. Each cross-correlation function shows the firing rate of one cell as a function of time relative to the occurrence of a spike in the second cell. Sharp peaks indicate synchronized firing at rates much higher than expected by chance; independent firing would result in flat cross-correlations. *B*: Each image (*left*, *right*) shows the pattern of firing in a collection of ON parasol RGCs simultaneously recorded during a 10 ms time interval (Shlens et al. 2006): Cells that fired a spike in this time interval have receptive fields colored red; cells that did not fire have receptive fields colored gray. Outlines represent the 0.8 SD contour of Gaussian fits to receptive fields. The clustering of red indicates spiking activity restricted to local patches in the RGC population.

model (Paninski et al. 2004, Pillow et al. 2005b) combined with functional interconnections between cells (see **Figure 5**) can provide an accurate account of firing in a complete local population of ON and OFF parasol RGCs (Pillow et al. 2005a). Another model produces similar results and is easier to implement (Paninski 2004, Pillow et al. 2005a, Truccolo et al. 2005). Again, the implications of these models for mechanism are uncertain. However, their empirical success may provide a way to identify quantitatively how synchronized firing influences the visual signal transmitted to the brain (see Decoding the Visual Signal from Retinal Spike Trains).

Implications

The significance of synchronized firing and other patterns of multineuron activity is a fundamental problem in many neural circuits (e.g., Castelo-Branco et al. 2000, Friedrich et al. 2004, Perez-Orive et al. 2002, Usrey et al. 1998; see Buzsaki 2004, Usrey & Reid 1999). The structure of synchronized firing in RGCs—regularity, spatial locality, and cell-type specificity—may provide clues about other neural structures. For example, as proposed above, a cell type–based organization of visual cortex may resemble that of the retina more closely than was previously appreciated. If so, synchronized firing among cortical neurons may be a useful clue for unraveling their cell type and subcircuit organization. Conversely, in the retina the spatial structure and functional organization of synchronized firing is extremely systematic in the presence of unambiguous cell-type classification (Mastrorarde 1983, Shlens et al. 2006) but less so in its absence (Meister et al. 1995, Schneidman et al. 2006). Thus, a more refined anatomical identification of cell types in cortex may be helpful in interpreting the functional significance of synchronized firing therein. Finally, new computational techniques for analyzing the complexity of synchronized firing in the retina may also be applicable to other neural circuits. For

example, maximum entropy approaches can be used to test whether synchronized firing can be explained by interactions among small groups of cells or instead reflects large and complex patterns of connectivity.

DECODING THE VISUAL SIGNAL FROM RETINAL SPIKE TRAINS

Background

In parallel with understanding visual encoding, recent research has begun to focus on the decoding problem, that is, how efficiently visual information can be extracted from the spatiotemporal structure of retinal spike trains. The decoding problem is fundamental to understanding visually guided behavior, in which an organism must exploit visual signals in real time to make inferences about the environment. The accuracy of these inferences may well contribute to evolutionary advantage. The value of analyzing decoding is that it can reveal what information about the visual scene is encoded in RGC signals and what information is lost (Bialek et al. 1991, de Ruyter van Steveninck & Bialek 1988, Fitzhugh 1957; see Bialek & Rieke 1992, Dayan & Abbott 2001, Rieke et al. 1997). For example, visual motion sensing depends on comparing the timing of responses in different RGCs; therefore, precise timing of RGC spikes (see Precision of Retinal Spike Trains and Models of the Neural Code) could provide a more reliable motion signal to the brain. However, this signal would be useful only if the brain were able to read it out accurately. A number of studies have applied ad hoc approaches to understand how visual signals can be decoded from retinal spike trains, using concepts from linear algebra and pattern classification theory (e.g., Chichilnisky & Rieke 2005, Dhingra & Smith 2004, Fitzhugh 1957, Lee et al. 1995). Recently, approaches that place more emphasis on the structure of real spike trains and the computations performed in the central visual system have provided important insight.

Advances

Linear reconstruction. In general, efficient decoding requires that one make assumptions about the nature of encoding. In the simplest cases, e.g., linear encoding with Gaussian noise, optimal decoding of the visual stimulus from neural responses is relatively simple. However, because real spike trains are significantly more complex (see *Precision of Retinal Spike Trains and Models of the Neural Code*), it is not obvious a priori what algorithms the brain must use to decode the retinal signal efficiently.

A straightforward empirical approach to this problem is to reconstruct the visual scene from recorded spike trains using the simplest possible algorithm: linear reconstruction, which is obtained by the superposition of elementary spatiotemporal patterns (or filters) associated with every recorded spike. The optimal reconstruction filter can be computed with linear regression (see Bialek et al. 1991, Rieke et al. 1997). One study used linear reconstruction to deduce the time course of a full-field stimulus from recordings of salamander RGCs (Warland et al. 1997). The results indicated that ON and OFF RGCs carried approximately independent information about the stimulus, which had long been suspected but not quantitatively tested.

Efficiency. For any reconstruction analysis one must test whether all the relevant information has been extracted from the spike train (Bialek et al. 1991); otherwise, the results may reveal more about flaws in analysis methodology than about the retinal signal. Given sufficient data, this verification can be performed by computing the mutual information between stimulus and response, a generic quantity from communications theory that places a firm upper bound on the degree to which the neural response characterizes the visual input (see Bialek et al. 1991, Rieke et al. 1997; but see Paninski 2003 for a discussion of significant biases in information estimates). One such test concluded that in

the case of powerful stimuli, linear reconstruction substantially failed to capture the information present in RGC spike trains (Passaglia & Troy 2004). This indicates that more elaborate techniques are required to understand the visual signals encoded in RGC spikes.

Model-based decoding. An alternative approach is to use a model of encoding that is accompanied by a decoding strategy known to be optimal. This approach explicitly acknowledges the fact that optimal decoding requires an accurate model for the statistics of neural responses. The challenge is to find the right balance of mathematical complexity in the model: complex enough to describe spike trains accurately, simple enough to yield a tractable decoding procedure. The LIF model (**Figure 5**; *Precision of Retinal Spike Trains and Models of the Neural Code*) (Pillow et al. 2005b) is one candidate, accounting for RGC spiking statistics at least as accurately as previous models, while providing an explicit mathematical procedure for decoding that is optimal (Paninski et al. 2004, Pillow et al. 2005b). The applications of this dual approach to the encoding and decoding problem may be numerous. For example, using the optimal decoding strategy, the LIF model was used to show that the non-Poisson temporal structure of RGC spike trains can be used to distinguish pairs of visual stimuli more efficiently than a decoding strategy based on firing rate alone (see *Precision of Retinal Spike Trains and Models of the Neural Code*) (Pillow et al. 2005b). More generally, the model makes it possible to test how effectively RGCs communicate information about different aspects of the visual stimulus. A similar approach may be valuable in obtaining a deeper understanding of the specific effects of synchronized firing on central visual function (see *Synchronized Firing and Consequences for Visual Signaling*).

Direct decoding from identified populations. A key challenge for the future is to understand how central structures can

decode visual signals from the ensemble activity of many RGCs. Recent advances in recording technology (Litke et al. 2004) have made it possible to examine the ensemble activity of complete populations of RGCs of several types simultaneously (Frechette et al. 2005, Shlens et al. 2006). Thus, one can test how all the features of the retinal population code—spatial sampling, regularity, temporal structure, and coordinated firing in multiple distinct types of RGCs—collectively govern decoding of behaviorally significant information in the brain.

One study focused on the representation of visual motion in parasol RGCs of primate retina (Frechette et al. 2005; see also Berry et al. 1999, Chichilnisky & Kalmar 2003, Sun et al. 2004). Parasol cells provide a major input to the magnocellular layers of LGN, which in turn provide a major input to motion-sensitive areas of the visual cortex (see Merigan & Maunsell 1993). Recordings were made of nearly complete collections of ON and OFF parasol cells sampling a region of the visual scene. Presentation of moving stimuli produced a traveling wave of activity, the spatial and temporal properties of which govern behavioral motion sensing. The fidelity of the retinal motion signal was assessed using a decoding approach based on standard computational models of motion sensing in the brain (Adelson & Bergen 1985, Reichardt 1961, Watson & Ahumada 1985), applied directly to recorded spike trains of parasol cells. The results indicated that the temporal resolution of the visual motion signal was coarse (~10 ms; Chichilnisky & Kalmar 2003), implying that millisecond timing precision may not be essential for conveying at least some natural visual signals. On the other hand, the non-Poisson nature of spike trains had a clear effect on the fidelity of the motion signal, confirming the importance of understanding spike train temporal structure in detail (see Precision of Retinal Spike Trains and Models of the Neural Code). ON and OFF parasol cells with overlapping receptive fields signaled motion information approximately indepen-

dently of one another, indicating a complementary role for these population signals (see also Warland et al. 1997). Synchronized firing among RGCs had surprisingly little impact on the representation of motion, highlighting the need to understand better the function of synchrony (see Synchronized Firing and Consequences for Visual Signaling). This study also suggested that a simple approach to motion decoding can effectively exploit the full spatio-temporal pattern of retinal activity, connecting theoretical decoding approaches with computations thought to occur in the brain (Emerson et al. 1992, Simoncelli & Heeger 1998). These findings suggest that direct approaches to decoding from identified populations may be useful in understanding the encoding of natural visual signals and its functional consequences.

Implications

The problem of decoding neural signals, particularly population signals, has broad implications for understanding nervous system function (e.g., Bialek et al. 1991, MacLeod et al. 1998, Mazor & Laurent 2005, Serruya et al. 2002, Theunissen & Miller 1991, Thomson & Kristan 2006, Wu et al. 2006; see Rieke et al. 1997). Because a major aspect of retinal function—to transmit an accurate visual image to the brain efficiently—can be stated precisely, the decoding problem can be framed and analyzed in concrete quantitative terms. This analysis has led to an important advance: accurate models of encoding accompanied by optimal decoding algorithms, tools that may be useful in studies of other neural structures (Jolivet et al. 2004, Truccolo et al. 2005). Another important advance has been the exploitation of multineuron recording and direct decoding techniques to examine how ensembles of identified RGCs collectively transmit behaviorally significant visual information to the brain. A major challenge for applying these approaches to other neural circuits will be to define clearly the information being transmitted and decoded, which is

fairly obvious in the case of the retina but may not be so obvious in other structures. Finally, an open question for future work is the biological feasibility of efficient decoding by real neurons (Deneve et al. 1999).

CONCLUSIONS

At the photoreceptor synapse, multiple distinct visual signals begin to emerge. These signals are processed by a diverse collection of bipolar and amacrine cell types (see **Figure 1**; Many Distinct Pathways of Visual Information Emanate from the Retina) that converge on at least 17 distinct types of RGCs (**Figure 2**), each of which covers the visual field with striking regularity (**Figure 3**). These are the elementary circuits of the retina. Each RGC type represents specific aspects of the visual scene (see Many Distinct Pathways of Visual Information Emanate from the Retina) using spatiotemporal patterns of action potentials with precise timing structure (see **Figure 4**; Precision of Retinal Spike Trains and Models

of the Neural Code) and stereotyped patterns of concerted activity (see **Figure 6**; Synchronized Firing and Consequences for Visual Signaling). These features shape the visual messages conveyed to the brain (**Figure 5**) and govern how effectively central circuits can decipher retinal signals (see Decoding the Visual Signal from Retinal Spike Trains) for the control of visually guided behavior.

The studies underlying this picture of retinal function also indicate important future directions for research on the retina, the visual system, and the nervous system as a whole. First, future studies will provide a deeper understanding if they exploit the great advantages of simultaneous recordings from many neurons and focus on morphological identification of recorded cells. Second, quantitative analysis and models of circuit function will benefit from consideration of both the nature of encoding in neural signals and the decoding that must be performed downstream. These themes may soon be applicable to many areas of neuroscience research.

ACKNOWLEDGMENTS

We thank J. Gauthier, M. Greschner, D. Marshak, J. Mitchel, L. Paninski, J. Pillow, F. Rieke, J. Shlens, and E. Simoncelli for comments on the manuscript; M. Grivich, A. Litke, and A. Sher for valuable discussions; D. Dacey and T. Haun for providing figure materials; and J. Simon for illustration assistance. This work was supported by a Helen Hay Whitney Postdoctoral Fellowship (GDF) and the McKnight Foundation (EJC).

LITERATURE CITED

- Ackert JM, Wu SH, Lee JC, Abrams J, Hu EH, et al. 2006. Light-induced changes in spike synchronization between coupled ON direction selective ganglion cells in the mammalian retina. *J. Neurosci.* 26:4206–15
- Adelson EH, Bergen JR. 1985. Spatiotemporal energy models for the perception of motion. *J. Opt. Soc. Am. A* 2:284–99
- Adrian ED. 1928. *The Basis of Sensation, the Action of the Sense Organs*. New York: Norton
- Amthor FR, Tootle JS, Gawne TJ. 2005. Retinal ganglion cell coding in simulated active vision. *Vis. Neurosci.* 22:789–806
- Barlow HB, Derrington AM, Harris LR, Lennie P. 1977. The effects of remote retinal stimulation on the responses of cat retinal ganglion cells. *J. Physiol.* 269:177–94
- Barlow HB, Hill RM. 1963. Selective sensitivity to direction of movement in ganglion cells of the rabbit retina. *Science* 139:412–14

- Baylor DA, Nunn BJ, Schnapf JL. 1987. Spectral sensitivity of cones of the monkey *Macaca fascicularis*. *J. Physiol.* 390:145–60
- Benardete EA, Kaplan E. 1997. The receptive field of the primate P retinal ganglion cell, I: linear dynamics. *Vis. Neurosci.* 14:169–85
- Benardete EA, Kaplan E. 1999. The dynamics of primate M retinal ganglion cells. *Vis. Neurosci.* 16:355–68
- Berry MJ, Brivanlou IH, Jordan TA, Meister M. 1999. Anticipation of moving stimuli by the retina. *Nature* 398:334–38
- Berry MJ, Meister M. 1998. Refractoriness and neural precision. *J. Neurosci.* 18:2200–11
- Berry MJ, Warland DK, Meister M. 1997. The structure and precision of retinal spike trains. *Proc. Natl. Acad. Sci. USA* 94:5411–16
- Berson DM, Dunn FA, Takao M. 2002. Phototransduction by retinal ganglion cells that set the circadian clock. *Science* 295:1070–73
- Bialek W, Rieke F. 1992. Reliability and information transmission in spiking neurons. *Trends Neurosci.* 15:428–34
- Bialek W, Rieke F, de Ruyter van Steveninck RR, Warland D. 1991. Reading a neural code. *Science* 252:1854–57
- Bordt AS, Hoshi H, Yamada ES, Perryman-Stout WC, Marshak DW. 2006. Synaptic input to OFF parasol ganglion cells in macaque retina. *J. Comp. Neurol.* 498:46–57
- Bowen RW, Pokorny J, Smith VC. 1989. Sawtooth contrast sensitivity: Decrements have the edge. *Vis. Res.* 29:1501–9
- Boycott BB, Wassle H. 1974. The morphological types of ganglion cells of the domestic cat's retina. *J. Physiol.* 240:397–419
- Boycott BB, Wassle H. 1991. Morphological classification of bipolar cells of the primate retina. *Eur. J. Neurosci.* 3:1069–88
- Brivanlou IH, Warland DK, Meister M. 1998. Mechanisms of concerted firing among retinal ganglion cells. *Neuron* 20:527–39
- Buzsaki G. 2004. Large scale recording of neuronal ensembles. *Nat. Neurosci.* 7:554–51
- Caldwell JH, Daw NW. 1978a. Effects of picrotoxin and strychnine on rabbit retinal ganglion cells: changes in center surround receptive fields. *J. Physiol.* 276:299–310
- Caldwell JH, Daw NW. 1978b. New properties of rabbit retinal ganglion cells. *J. Physiol.* 276:257–76
- Caldwell JH, Daw NW, Wyatt HJ. 1978. Effects of picrotoxin and strychnine on rabbit retinal ganglion cells: lateral interactions for cells with more complex receptive fields. *J. Physiol.* 276:277–98
- Calkins DJ, Schein SJ, Tsukamoto Y, Sterling P. 1994. M and L cones in macaque fovea connect to midget ganglion cells by different numbers of excitatory synapses. *Nature* 371:70–72
- Calkins DJ, Tsukamoto Y, Sterling P. 1998. Microcircuitry and mosaic of a blue-yellow ganglion cell in the primate retina. *J. Neurosci.* 18:3373–85
- Callaway EM. 2002. Cell type specificity of local cortical connections. *J. Neurocytol.* 31:231–37
- Callaway EM. 2004. Feedforward, feedback and inhibitory connections in primate visual cortex. *Neural Netw.* 17:625–32
- Callaway EM. 2005. Structure and function of parallel pathways in the primate early visual system. *J. Physiol.* 566:13–19
- Castelo-Branco M, Goebel R, Neuenschwander S, Singer W. 2000. Neural synchrony correlates with surface segregation rules. *Nature* 405:685–89
- Chatterjee S, Callaway EM. 2003. Parallel colour-opponent pathways to primary visual cortex. *Nature* 426:668–71

- Chichilnisky EJ, Kalmar RS. 2002. Functional asymmetries in ON and OFF ganglion cells of primate retina. *J. Neurosci.* 22:2737–47
- Chichilnisky EJ, Kalmar RS. 2003. Temporal resolution of ensemble visual motion signals in primate retina. *J. Neurosci.* 23:6681–89
- Chichilnisky EJ, Rieke F. 2005. Detection sensitivity and temporal resolution of visual signals near absolute threshold in the salamander retina. *J. Neurosci.* 25:318–30
- Chichilnisky EJ, Wandell BA. 1996. Seeing gray through the ON and OFF pathways. *Vis. Neurosci.* 13:591–96
- Cleland BG, Dubin MW, Levick WR. 1971. Sustained and transient neurones in the cat's retina and lateral geniculate nucleus. *J. Physiol.* 217:473–96
- Cleland BG, Levick WR. 1974a. Brisk and sluggish concentrically organized ganglion cells in the cat's retina. *J. Physiol.* 240:421–56
- Cleland BG, Levick WR. 1974b. Properties of rarely encountered types of ganglion cells in the cat's retina and an overall classification. *J. Physiol.* 240:457–92
- Cohen E, Sterling P. 1990. Demonstration of cell types among cone bipolar neurons of cat retina. *Philos. Trans. R. Soc. London B Biol. Sci.* 330:305–21
- Dacey DM. 1993a. Morphology of a small-field bistratified ganglion cell type in the macaque and human retina. *Vis. Neurosci.* 10:1081–98
- Dacey DM. 1993b. The mosaic of midget ganglion cells in the human retina. *J. Neurosci.* 13:5334–55
- Dacey DM. 2000. Parallel pathways for spectral coding in primate retina. *Annu. Rev. Neurosci.* 23:743–75
- Dacey DM. 2004. Origins of perception: retinal ganglion cell diversity and the creation of parallel visual pathways. In *The Cognitive Neurosciences*, ed. MS Gazzaniga, pp. 281–301. Cambridge, MA: MIT Press
- Dacey DM, Brace S. 1992. A coupled network for parasol but not midget ganglion cells in the primate retina. *Vis. Neurosci.* 9:279–90
- Dacey DM, Lee BB. 1994. The “blue-on” opponent pathway in primate retina originates from a distinct bistratified ganglion cell type. *Nature* 367:731–35
- Dacey DM, Lee BB, Stafford DK, Pokorny J, Smith VC. 1996. Horizontal cells of the primate retina: cone specificity without spectral opponency. *Science* 271:656–59
- Dacey DM, Liao HW, Peterson BB, Robinson FR, Smith VC, et al. 2005. Melanopsin-expressing ganglion cells in primate retina signal color and irradiance and project to the LGN. *Nature* 433:749–54
- Dacey DM, Petersen MR. 1992. Dendritic field size and morphology of midget and parasol ganglion cells of the human retina. *Proc. Natl. Acad. Sci. USA* 89:9666–70
- Dacey DM, Peterson BB, Robinson FR, Gamlin PD. 2003. Fireworks in the primate retina: in vitro photodynamics reveals diverse LGN-projecting ganglion cell types. *Neuron* 37:15–27
- Daw NW, Ariel M. 1981. Effect of synaptic transmitter drugs on receptive fields of rabbit retinal ganglion cells. *Vis. Res.* 21:1643–47
- Dayan P, Abbott LF. 2001. *Theoretical Neuroscience: Computational and Mathematical Modeling of Neural Systems*. Cambridge, MA: MIT Press
- de Monasterio FM. 1978. Properties of concentrically organized X and Y ganglion cells of macaque retina. *J. Neurophysiol.* 41:1394–417
- de Monasterio FM, Gouras P. 1975. Functional properties of ganglion cells of the rhesus monkey retina. *J. Physiol.* 251:167–95
- de Ruyter van Steveninck RR, Bialek W. 1988. Real-time performance of a movement-sensitive neuron in the blowfly visual system: coding and information transfer in short spike sequences. *Proc. R. Soc. London Ser. B* 234:379–414

- Demb JB, Haarsma L, Freed MA, Sterling P. 1999. Functional circuitry of the retinal ganglion cell's nonlinear receptive field. *J. Neurosci.* 19:9756–67
- Deneve S, Latham PE, Pouget A. 1999. Reading population codes: a neural implementation of ideal observers. *Nat. Neurosci.* 2:740–45
- DeVries SH. 1999. Correlated firing in rabbit retinal ganglion cells. *J. Neurophysiol.* 81:908–20
- DeVries SH. 2000. Bipolar cells use kainate and AMPA receptors to filter visual information into separate channels. *Neuron* 28:847–56
- DeVries SH, Baylor DA. 1997. Mosaic arrangement of ganglion cell receptive fields in rabbit retina. *J. Neurophysiol.* 78:2048–60
- DeVries SH, Li W, Saszik S. 2006. Parallel processing in two transmitter microenvironments at the cone photoreceptor synapse. *Neuron* 50:735–48
- Dhingra NK, Smith RG. 2004. Spike generator limits efficiency of information transfer in a retinal ganglion cell. *J. Neurosci.* 24:2914–22
- Dong CJ, Werblin FS. 1998. Temporal contrast enhancement via GABAC feedback at bipolar terminals in the tiger salamander retina. *J. Neurophysiol.* 79:2171–80
- Dowling JE. 1987. *The Retina: An Approachable Part of the Brain*. Cambridge, MA: Belknap Press of Harvard Univ. Press
- Eglen SJ, Diggle PJ, Troy JB. 2005. Homotypic constraints dominate positioning of on- and off-center beta retinal ganglion cells. *Vis. Neurosci.* 22:859–71
- Emerson RC, Bergen JR, Adelson EH. 1992. Directionally selective complex cells and the computation of motion energy in cat visual cortex. *Vis. Res.* 32:203–18
- Enroth-Cugell C, Robson JG. 1966. The contrast sensitivity of retinal ganglion cells of the cat. *J. Physiol.* 187:517–22
- Field GD, Sampath AP, Rieke F. 2005. Retinal processing near absolute threshold: from behavior to mechanism. *Annu. Rev. Physiol.* 67:491–514
- Fitzhugh R. 1957. The statistical detection of threshold signals in the retina. *J. Gen. Physiol.* 40:925–48
- Frechette ES, Sher A, Grivich MI, Petrusca D, Litke AM, Chichilnisky EJ. 2005. Fidelity of the ensemble code for visual motion in primate retina. *J. Neurophysiol.* 94:119–35
- Friedrich RW, Habermann CJ, Laurent G. 2004. Multiplexing using synchrony in the zebrafish olfactory bulb. *Nat. Neurosci.* 7:862–71
- Frishman LJ, Linsenmeier RA. 1982. Effects of picrotoxin and strychnine on nonlinear responses of Y-type cat retinal ganglion cells. *J. Physiol.* 324:347–63
- Fukuda Y, Hsiao CF, Watanabe M, Ito H. 1984. Morphological correlates of physiologically identified Y-, X-, and W-cells in cat retina. *J. Neurophysiol.* 52:999–1013
- Ghosh KK, Grunert U. 1999. Synaptic input to small bistratified (blue-ON) ganglion cells in the retina of a new world monkey, the marmoset *Callithrix jacchus*. *J. Comp. Neurol.* 413:417–28
- Ghosh KK, Bujan S, Haverkamp S, Feigenspan A, Wässle H. 2004. Types of bipolar cells in the mouse retina. *J. Comp. Neurol.* 469:70–82
- Gouras P. 1968. Identification of cone mechanisms in monkey ganglion cells. *J. Physiol.* 199:533–47
- Gouras P. 1991. *The Perception of Color*. Boca Raton, FL: CRC Press
- Grivich MI, Sher A, Petrusca D, Field GD, Shlens J, et al. 2005. Classification of guinea pig retinal ganglion cells using large scale multielectrode recordings. *Soc. Neurosci. Abstr.* 31
- Grunert U, Martin PR, Wässle H. 1994. Immunocytochemical analysis of bipolar cells in the macaque monkey retina. *J. Comp. Neurol.* 348:607–27

- Hattar S, Liao HW, Takao M, Berson DM, Yau KW. 2002. Melanopsin-containing retinal ganglion cells: architecture, projections, and intrinsic photosensitivity. *Science* 295:1065–70
- Hattar S, Lucas RJ, Mrosovsky N, Thompson S, Douglas RH, et al. 2003. Melanopsin and rod-cone photoreceptive systems account for all major accessory visual functions in mice. *Nature* 424:76–81
- Haverkamp S, Grunert U, Wässle H. 2000. The cone pedicle, a complex synapse in the retina. *Neuron* 27:85–95
- Hendry SH, Reid RC. 2000. The koniocellular pathway in primate vision. *Annu. Rev. Neurosci.* 23:127–53
- Hidaka S, Akahori Y, Kurosawa Y. 2004. Dendrodendritic electrical synapses between mammalian retinal ganglion cells. *J. Neurosci.* 24:10553–67
- Hochstein S, Shapley RM. 1976. Linear and nonlinear spatial subunits in Y cat retinal ganglion cells. *J. Physiol.* 262:265–84
- Hofman MA, Zhou JN, Swaab DF. 1996. Suprachiasmatic nucleus of the human brain: an immunocytochemical and morphometric analysis. *Anat. Rec.* 244:552–62
- Hu EH, Bloomfield SA. 2003. Gap junctional coupling underlies the short-latency spike synchrony of retinal alpha ganglion cells. *J. Neurosci.* 23:6768–77
- Jacobs AL, Werblin FS. 1998. Spatiotemporal patterns at the retinal output. *J. Neurophysiol.* 80:447–51
- Jacoby RA, Stafford D, Kouyama N, Marshak D. 1996. Synaptic inputs to ON parasol ganglion cells in the primate retina. *J. Neurosci.* 16:8041–56
- Jacoby RA, Wiechmann AF, Amara SG, Leighton BH, Marshak DW. 2000. Diffuse bipolar cells provide input to OFF parasol ganglion cells in the macaque retina. *J. Comp. Neurol.* 416:6–18
- Jolivet R, Lewis TJ, Gerstner W. 2004. Generalized integrate-and-fire models of neuronal activity approximate spike trains of a detailed model to a high degree of accuracy. *J. Neurophysiol.* 92:959–76
- Kaplan E. 2004. The M, P, and K pathways of the primate visual system. In *The Visual Neurosciences*, ed. LM Chalupa, JS Werner, pp. 481–93. Cambridge, MA: MIT Press
- Kaplan E, Shapley RM. 1982. X and Y cells in the lateral geniculate nucleus of macaque monkeys. *J. Physiol.* 330:125–43
- Kaplan E, Shapley RM. 1986. The primate retina contains two types of ganglion cells, with high and low contrast sensitivity. *Proc. Natl. Acad. Sci. USA* 83:2755–57
- Kara P, Reid RC. 2003. Efficacy of retinal spikes in driving cortical responses. *J. Neurosci.* 23:8547–57
- Kawaguchi Y, Kondo S. 2002. Parvalbumin, somatostatin and cholecystokinin as chemical markers for specific GABAergic interneuron types in the rat frontal cortex. *J. Neurocytol.* 31:277–87
- Keat J, Reinagel P, Reid RC, Meister M. 2001. Predicting every spike: a model for the responses of visual neurons. *Neuron* 30:803–17
- Kolb H. 1997. Amacrine cells of the mammalian retina: neurocircuitry and functional roles. *Eye* 11:904–23
- Kolb H, Dekorver L. 1991. Midget ganglion cells of the parafovea of the human retina: a study by electron microscopy and serial section reconstructions. *J. Comp. Neurol.* 303:617–36
- Kolb H, Marshak D. 2003. The midget pathways of the primate retina. *Doc. Ophthalmol.* 106:67–81
- Kouyama N, Marshak DW. 1992. Bipolar cells specific for blue cones in the macaque retina. *J. Neurosci.* 12:1233–52

- Kremers J, Lee BB, Pokorny J, Smith VC. 1993. Responses of macaque ganglion cells and human observers to compound periodic waveforms. *Vis. Res.* 33:1997–2011
- Latham PE, Nirenberg S. 2005. Synergy, redundancy, and independence in population codes, revisited. *J. Neurosci.* 25:5195–206
- Lee BB. 1996. Receptive field structure in the primate retina. *Vis. Res.* 36:631–44
- Lee BB, Martin PR, Valberg A. 1989. Nonlinear summation of M- and L-cone inputs to phasic retinal ganglion cells of the macaque. *J. Neurosci.* 9:1433–42
- Lee BB, Wehrhahn C, Westheimer G, Kremers J. 1995. The spatial precision of macaque ganglion cell responses in relation to vernier acuity of human observers. *Vis. Res.* 35:2743–58
- Litke AM, Bezaiff N, Chichilnisky EJ, Cunningham W, Dabrowski W, et al. 2004. What does the eye tell the brain? Development of a system for the large scale recording of retinal output activity. *IEEE Trans. Nucl. Sci.* 51:1434–40
- Livingstone MS, Hubel DH. 1988. Segregation of form, color, movement, and depth: anatomy, physiology, and perception. *Science* 240:740–49
- Lukasiewicz PD. 2005. Synaptic mechanisms that shape visual signaling at the inner retina. *Prog. Brain Res.* 147:205–18
- MacLeod K, Backer A, Laurent G. 1998. Who reads temporal information contained across synchronized and oscillatory spike trains? *Nature* 395:693–98
- MacNeil MA, Heussy JK, Dacheux RF, Raviola E, Masland RH. 1999. The shapes and numbers of amacrine cells: matching of photofilled with Golgi-stained cells in the rabbit retina and comparison with other mammalian species. *J. Comp. Neurol.* 413:305–26
- Mangel SC. 1991. Analysis of the horizontal cell contribution to the receptive field surround of ganglion cells in the rabbit retina. *J. Physiol.* 442:211–34
- Marshak DW, Yamada ES, Bordt AS, Perryman WC. 2002. Synaptic input to an ON parasol ganglion cell in the macaque retina: a serial section analysis. *Vis. Neurosci.* 19:299–305
- Martin PR, White AJ, Goodchild AK, Wilder HD, Sefton AE. 1997. Evidence that blue-on cells are part of the third geniculocortical pathway in primates. *Eur. J. Neurosci.* 9:1536–41
- Masland RH. 2001. The fundamental plan of the retina. *Nat. Neurosci.* 4:877–86
- Mason C, Kandel ER. 1991. Central visual pathways. In *Principles of Neural Science*, ed. ER Kandel, JH Schwartz, TM Jessell, pp. 420–39. New York: Elsevier
- Mastrorarde DN. 1983. Correlated firing of cat retinal ganglion cells. I. Spontaneously active inputs to X- and Y-cells. *J. Neurophysiol.* 49:303–24
- Mazor O, Laurent G. 2005. Transient dynamics versus fixed points in odor representations by locust antennal lobe projection neurons. *Neuron* 48:661–73
- McGuire BA, Stevens JK, Sterling P. 1984. Microcircuitry of bipolar cells in cat retina. *J. Neurosci.* 4:2920–38
- McGuire BA, Stevens JK, Sterling P. 1986. Microcircuitry of beta ganglion cells in cat retina. *J. Neurosci.* 6:907–18
- McIlwain JT. 1964. Receptive fields of optic tract axons and lateral geniculate cells: peripheral extent and barbiturate sensitivity. *J. Neurophysiol.* 27:1154–73
- McMahon MJ, Packer OS, Dacey DM. 2004. The classical receptive field surround of primate parasol ganglion cells is mediated primarily by a non-GABAergic pathway. *J. Neurosci.* 24:3736–45
- Meister M. 1996. Multineuronal codes in retinal signaling. *Proc. Natl. Acad. Sci. USA* 93:609–14
- Meister M, Berry MJ. 1999. The neural code of the retina. *Neuron* 22:435–50
- Meister M, Lagnado L, Baylor DA. 1995. Concerted signaling by retinal ganglion cells. *Science* 270:1207–10

- Merigan WH, Maunsell JH. 1993. How parallel are the primate visual pathways? *Annu. Rev. Neurosci.* 16:369–402
- Neuenschwander S, Castelo-Branco M, Singer W. 1999. Synchronous oscillations in the cat retina. *Vis. Res.* 39:2485–97
- Neuenschwander S, Singer W. 1996. Long-range synchronization of oscillatory light responses in the cat retina and lateral geniculate nucleus. *Nature* 379:728–32
- Nirenberg S, Carcieri SM, Jacobs AL, Latham PE. 2001. Retinal ganglion cells act largely as independent encoders. *Nature* 411:698–701
- Nirenberg S, Meister M. 1997. The light response of retinal ganglion cells is truncated by a displaced amacrine circuit. *Neuron* 18:637–50
- Olveczky BP, Baccus SA, Meister M. 2003. Segregation of object and background motion in the retina. *Nature* 423:401–8
- Paninski L. 2003. Estimation of entropy and mutual information. *Neural Comput.* 15:1191–253
- Paninski L. 2004. Maximum likelihood estimation of cascade point-process neural encoding models. *Network* 15:243–62
- Paninski L, Pillow JW, Simoncelli EP. 2004. Maximum likelihood estimation of a stochastic integrate-and-fire neural encoding model. *Neural Comput.* 16:2533–61
- Passaglia CL, Enroth-Cugell C, Troy JB. 2001. Effects of remote stimulation on the mean firing rate of cat retinal ganglion cells. *J. Neurosci.* 21:5794–803
- Passaglia CL, Troy JB. 2004. Information transmission rates of cat retinal ganglion cells. *J. Neurophysiol.* 91:1217–29
- Peichl L, Wässle H. 1981. Morphological identification of on- and off-center brisk transient (Y) cells in the cat retina. *Proc. R. Soc. London B Biol. Sci.* 212:139–53
- Perez-Orive J, Mazor O, Turner GC, Cassenaer S, Wilson RI, Laurent G. 2002. Oscillations and sparsening of odor representations in the mushroom body. *Science* 297:359–65
- Perry VH, Oehler R, Cowey A. 1984. Retinal ganglion cells that project to the dorsal lateral geniculate nucleus in the macaque monkey. *Neuroscience* 12:1101–23
- Petrusca D, Grivich MI, Sher A, Field GD, Gauthier JL, et al. 2005. Physiological characterization of a new macaque retinal ganglion cell class. *Soc. Neurosci. Abstr.* 31
- Pillow JW, Paninski L, Uzzell VJ, Simoncelli EP, Chichilnisky EJ. 2005b. Prediction and decoding of retinal ganglion cell responses with a probabilistic spiking model. *J. Neurosci.* 25:11003–13
- Pillow JW, Shlens J, Paninski L, Chichilnisky EJ, Simoncelli EP. 2005a. Modeling the correlated spike responses of a cluster of primate retinal ganglion cells. *Soc. Neurosci. Abstr.* 31
- Puchalla JL, Schneidman E, Harris RA, Berry MJ. 2005. Redundancy in the population code of the retina. *Neuron* 46:493–504
- Reich DS, Victor JD, Knight BW. 1998. The power ratio and the interval map: spiking models and extracellular recordings. *J. Neurosci.* 18:10090–104
- Reich DS, Victor JD, Knight BW, Ozaki T, Kaplan E. 1997. Response variability and timing precision of neuronal spike trains in vivo. *J. Neurophysiol.* 77:2836–41
- Reichardt W. 1961. *Autocorrelation, A Principle for the Evaluation of Sensory Information by the Central Nervous System*. Cambridge, MA: MIT Press
- Reid RC. 1999. Vision. In *Fundamental Neuroscience*, ed. MJ Zigmond, FE Bloom, SC Landis, JL Roberts, LR Squire, pp. 821–51. San Diego: Academic
- Rieke F, Warland D, de Ruyter van Steveninck RR, Bialek W. 1997. *Spikes: Exploring the Neural Code*. Cambridge, MA: MIT Press
- Rockhill RL, Daly FJ, MacNeil MA, Brown SP, Masland RH. 2002. The diversity of ganglion cells in a mammalian retina. *J. Neurosci.* 22:3831–43

- Rockhill RL, Euler T, Masland RH. 2000. Spatial order within but not between types of retinal neurons. *Proc. Natl. Acad. Sci. USA* 97:2303–7
- Rodieck RW. 1988. The primate retina. In *Neurosciences*, ed. HD Steklis, J Erwin, pp. 203–78. New York: Liss
- Rodieck RW. 1998. *The First Steps in Seeing*. Sunderland, MA: Sinauer
- Rodieck RW, Binmoeller KF, Dineen J. 1985. Parasol and midget ganglion cells of the human retina. *J. Comp. Neurol.* 233:115–32
- Rodieck RW, Watanabe M. 1993. Survey of the morphology of macaque retinal ganglion cells that project to the pretectum, superior colliculus, and parvicellular laminae of the lateral geniculate nucleus. *J. Comp. Neurol.* 338:289–303
- Roska B, Werblin F. 2001. Vertical interactions across ten parallel, stacked representations in the mammalian retina. *Nature* 410:583–87
- Roska B, Werblin F. 2003. Rapid global shifts in natural scenes block spiking in specific ganglion cell types. *Nat. Neurosci.* 6:600–8
- Saito HA. 1983. Morphology of physiologically identified X-, Y-, and W-type retinal ganglion cells of the cat. *J. Comp. Neurol.* 221:279–88
- Schein S, Sterling P, Ngo IT, Huang TM, Herr S. 2004. Evidence that each S cone in macaque fovea drives one narrow-field and several wide-field blue-yellow ganglion cells. *J. Neurosci.* 24:8366–78
- Schiller PH. 1992. The ON and OFF channels of the visual system. *Trends Neurosci.* 15:86–92
- Schneidman E, Berry MJ, Segev R, Bialek W. 2006. Weak pairwise correlations imply strongly correlated network states in a neural population. *Nature* 440:1007–12
- Schneidman E, Bialek W, Berry MJ. 2003a. Synergy, redundancy, and independence in population codes. *J. Neurosci.* 23:11539–53
- Schneidman E, Still S, Berry MJ, Bialek W. 2003b. Network information and connected correlations. *Phys. Rev. Lett.* 91:238701–4
- Schnitzer MJ, Meister M. 2003. Multineuronal firing patterns in the signal from eye to brain. *Neuron* 37:499–511
- Schubert T, Degen J, Willecke K, Hormuzdi SG, Monyer H, Weiler R. 2005. Connexin36 mediates gap junctional coupling of alpha-ganglion cells in mouse retina. *J. Comp. Neurol.* 485:191–201
- Segev R, Puchalla J, Berry MJ. 2006. The functional organization of ganglion cells in the salamander retina. *J. Neurophysiol.* 95:2277–92
- Serruya MD, Hatsopoulos NG, Paninski L, Fellows MR, Donoghue JP. 2002. Instant neural control of a movement signal. *Nature* 416:141–42
- Shapley RM, Perry VH. 1986. Cat and monkey retinal ganglion cells and their visual functional roles. *Trends Neurosci.* 9:229–35
- Shapley RM, Victor JD. 1978. The effect of contrast on the transfer properties of cat retinal ganglion cells. *J. Physiol. (London)* 285:275–98
- Shlens J, Field GD, Gauthier JL, Grivich MI, Petrusca D, et al. 2006. The structure of multi-neuron firing patterns in primate retina. *J. Neurosci.* 26:8254–66
- Silveira LC, Saito CA, Lee BB, Kremers J, da Silva Filho M, et al. 2004. Morphology and physiology of primate M- and P-cells. *Prog. Brain Res.* 144:21–46
- Simoncelli EP, Heeger DJ. 1998. A model of neuronal responses in visual area MT. *Vis. Res.* 38:743–61
- Somogyi P, Klausberger T. 2005. Defined types of cortical interneurone structure space and spike timing in the hippocampus. *J. Physiol.* 562:9–26
- Sterling P, Demb JB. 2004. Retina. In *The Synaptic Organization of the Brain*, ed. GM Shepherd, pp. 217–69. New York: Oxford Univ. Press

- Sun H, Ruttiger L, Lee BB. 2004. The spatiotemporal precision of ganglion cell signals: a comparison of physiological and psychophysical performance with moving gratings. *Vis. Res.* 44:19–33
- Taylor WR, Vaney DI. 2003. New directions in retinal research. *Trends Neurosci.* 26:379–85
- Theunissen FE, Miller JP. 1991. Representation of sensory information in the cricket cercal sensory system. II. Information theoretic calculation of system accuracy and optimal tuning-curve widths of four primary interneurons. *J. Neurophysiol.* 66:1690–1703
- Thomson EE, Kristan WB. 2006. Encoding and decoding touch location in the leech CNS. *J. Neurosci.* 26:8009–16
- Troy JB, Lee BB. 1994. Steady discharges of macaque retinal ganglion cells. *Vis. Neurosci.* 11:111–18
- Troy JB, Robson JG. 1992. Steady discharges of X and Y retinal ganglion cells of cat under photopic illuminance. *Vis. Neurosci.* 9:535–53
- Troy JB, Shou T. 2002. The receptive fields of cat retinal ganglion cells in physiological and pathological states: where we are after half a century of research. *Prog. Retin. Eye Res.* 21:263–302
- Truccolo W, Eden UT, Fellows MR, Donoghue JP, Brown EN. 2005. A point process framework for relating neural spiking activity to spiking history, neural ensemble, and extrinsic covariate effects. *J. Neurophysiol.* 93:1074–89
- Usrey WM, Reid RC. 1999. Synchronous activity in the visual system. *Annu. Rev. Physiol.* 61:435–56
- Usrey WM, Reppas JB, Reid RC. 1998. Paired-spike interactions and synaptic efficacy of retinal inputs to the thalamus. *Nature* 395:384–87
- Uzzell VJ, Chichilnisky EJ. 2004. Precision of spike trains in primate retinal ganglion cells. *J. Neurophysiol.* 92:780–89
- Van Hooser SD, Heimel JA, Nelson SB. 2003. Receptive field properties and laminar organization of lateral geniculate nucleus in the gray squirrel (*Sciurus carolinensis*). *J. Neurophysiol.* 90:3398–418
- Verweij J, Hornstein EP, Schnapf JL. 2003. Surround antagonism in macaque cone photoreceptors. *J. Neurosci.* 23:10249–57
- Victor JD. 1999. Temporal aspects of neural coding in the retina and lateral geniculate. *Network* 10:R1–66
- Volgyi B, Abrams J, Paul DL, Bloomfield SA. 2005. Morphology and tracer coupling pattern of alpha ganglion cells in the mouse retina. *J. Comp. Neurol.* 492:66–77
- Warland DK, Reinagel P, Meister M. 1997. Decoding visual information from a population of retinal ganglion cells. *J. Neurophysiol.* 78:2336–50
- Wassle H. 2004. Parallel processing in the mammalian retina. *Nat. Rev. Neurosci.* 5:747–57
- Wassle H, Boycott BB. 1991. Functional architecture of the mammalian retina. *Physiol. Rev.* 71:447–80
- Wassle H, Boycott BB, Illing RB. 1981a. Morphology and mosaic of on- and off-beta cells in the cat retina and some functional considerations. *Proc. R. Soc. London B Biol. Sci.* 212:177–95
- Wassle H, Dacey DM, Haun T, Haverkamp S, Grunert U, Boycott BB. 2000. The mosaic of horizontal cells in the macaque monkey retina: with a comment on bplexiform ganglion cells. *Vis. Neurosci.* 17:591–608
- Wassle H, Peichl L, Boycott BB. 1981b. Dendritic territories of cat retinal ganglion cells. *Nature* 292:344–45
- Wassle H, Peichl L, Boycott BB. 1981c. Morphology and topography of on- and off-alpha cells in the cat retina. *Proc. R. Soc. London B Biol. Sci.* 212:157–75

- Wassle H, Peichl L, Boycott BB. 1983. A spatial analysis of on- and off-ganglion cells in the cat retina. *Vis. Res.* 23:1151–60
- Watanabe M, Rodieck RW. 1989. Parasol and midget ganglion cells of the primate retina. *J. Comp. Neurol.* 289:434–54
- Watson AB, Ahumada AJ Jr. 1985. Model of human visual-motion sensing. *J. Opt. Soc. Am. [A]* 2:322–41
- Wehrhahn C, Rapf D. 1992. ON- and OFF-pathways form separate neural substrates for motion perception: psychophysical evidence. *J. Neurosci.* 12:2247–50
- Weng S, Sun W, He S. 2005. Identification of ON-OFF direction-selective ganglion cells in the mouse retina. *J. Physiol.* 562:915–23
- White AJ, Solomon SG, Martin PR. 2001. Spatial properties of koniocellular cells in the lateral geniculate nucleus of the marmoset *Callithrix jacchus*. *J. Physiol.* 533:519–35
- White AJ, Wilder HD, Goodchild AK, Sefton AJ, Martin PR. 1998. Segregation of receptive field properties in the lateral geniculate nucleus of a New-World monkey, the marmoset *Callithrix jacchus*. *J. Neurophysiol.* 80:2063–76
- Wu W, Gao Y, Bienenstock E, Donoghue JP, Black MJ. 2006. Bayesian population decoding of motor cortical activity using a Kalman filter. *Neural Comput.* 18:80–118
- Xu X, Ichida JM, Allison JD, Boyd JD, Casagrande VA, Bonds AB. 2001. A comparison of koniocellular, magnocellular and parvocellular receptive field properties in the lateral geniculate nucleus of the owl monkey (*Aotus trivirgatus*). *J. Physiol.* 531:203–18
- Yamada ES, Bordt AS, Marshak DW. 2005. Wide-field ganglion cells in macaque retinas. *Vis. Neurosci.* 22:383–93
- Yamada ES, Dmitrieva N, Keyser KT, Lindstrom JM, Hersh LB, Marshak DW. 2003. Synaptic connections of starburst amacrine cells and localization of acetylcholine receptors in primate retinas. *J. Comp. Neurol.* 461:76–90
- Zhang J, Li W, Hoshi H, Mills SL, Massey SC. 2005. Stratification of alpha ganglion cells and ON/OFF directionally selective ganglion cells in the rabbit retina. *Vis. Neurosci.* 22:535–49
- Zrenner E, Abramov I, Akita M, Cowey A, Livingstone M, Valberg A. 1990. Color perception. In *Visual Perception: The Neurophysiological Foundations*, ed. L. Spillman, JS Werner, pp. 163–204. San Diego: Academic



Contents

Information Processing in the Primate Retina: Circuitry and Coding <i>G.D. Field and E.Ĵ. Chichilnisky</i>	1
Orbitofrontal Cortex and Its Contribution to Decision-Making <i>Jonathan D. Wallis</i>	31
Fundamental Components of Attention <i>Eric I. Knudsen</i>	57
Anatomical and Physiological Plasticity of Dendritic Spines <i>Veronica A. Alvarez and Bernardo L. Sabatini</i>	79
Visual Perception and Memory: A New View of Medial Temporal Lobe Function in Primates and Rodents <i>Elisabeth A. Murray, Timothy Ĵ. Bussey, and Lisa M. Saksida</i>	99
The Medial Temporal Lobe and Recognition Memory <i>H. Eichenbaum, A.P. Yonelinas, and C. Ranganath</i>	123
Why Is Wallerian Degeneration in the CNS So Slow? <i>Mauricio E. Vargas and Ben A. Barres</i>	153
The Head Direction Signal: Origins and Sensory-Motor Integration <i>Jeffrey S. Taube</i>	181
Peripheral Regeneration <i>Zu-Lin Chen, Wei-Ming Yu, and Sidney Strickland</i>	209
Neuron-Glial Interactions in Blood-Brain Barrier Formation <i>Swati Banerjee and Manzoor A. Bhat</i>	235
Multiple Dopamine Functions at Different Time Courses <i>Wolfram Schultz</i>	259
Ventral Tegmental Area Neurons in Learned Appetitive Behavior and Positive Reinforcement <i>Howard L. Fields, Gregory O. Hjelmstad, Elyssa B. Margolis, and Saleem M. Nicola</i>	289

Copper and Iron Disorders of the Brain <i>Erik Madsen and Jonathan D. Gitlin</i>	317
The Micromachinery of Mechanotransduction in Hair Cells <i>Melissa A. Vollrath, Kelvin Y. Kwan, and David P. Corey</i>	339
Neurobiology of Feeding and Energy Expenditure <i>Qian Gao and Tamas L. Horvath</i>	367
Mechanisms that Regulate Establishment, Maintenance, and Remodeling of Dendritic Fields <i>Jay Z. Parrish, Kazuo Emoto, Michael D. Kim, and Yuh Nung Jan</i>	399
Dynamic Aspects of CNS Synapse Formation <i>A. Kimberley McAllister</i>	425
Adhesion Molecules in the Nervous System: Structural Insights into Function and Diversity <i>Lawrence Shapiro, James Love, and David R. Colman</i>	451
Development of Neural Systems for Reading <i>Bradley L. Schlaggar and Bruce D. McCandliss</i>	475
Molecular Architecture of Smell and Taste in <i>Drosophila</i> <i>Leslie B. Vosshall and Reinhard F. Stocker</i>	505
The Neural Basis of Decision Making <i>Joshua I. Gold and Michael N. Shadlen</i>	535
Trinucleotide Repeat Disorders <i>Harry T. Orr and Huda Y. Zoghbi</i>	575
Indexes	
Cumulative Index of Contributing Authors, Volumes 21–30	623
Cumulative Index of Chapter Titles, Volumes 21–30	627

Errata

An online log of corrections to *Annual Review of Neuroscience* chapters (if any, 1997 to the present) may be found at <http://neuro.annualreviews.org/>