

Crystal Flowers  
in Halls of Mirrors:

EXAMPLES OF  
MATHEMATICS  
IN VISUAL ARTS

24.1.2019  
Taneli Luotoniemi

# Tilings

# PLATONIC TILINGS

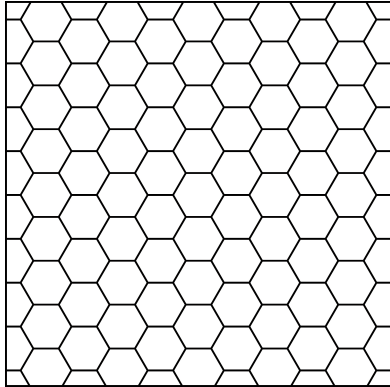
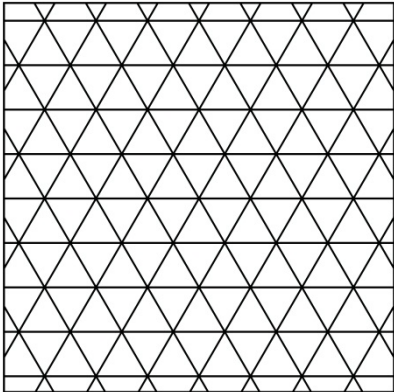
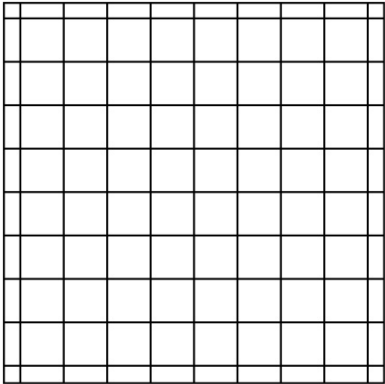

# ARCHIMEDEAN TILINGS

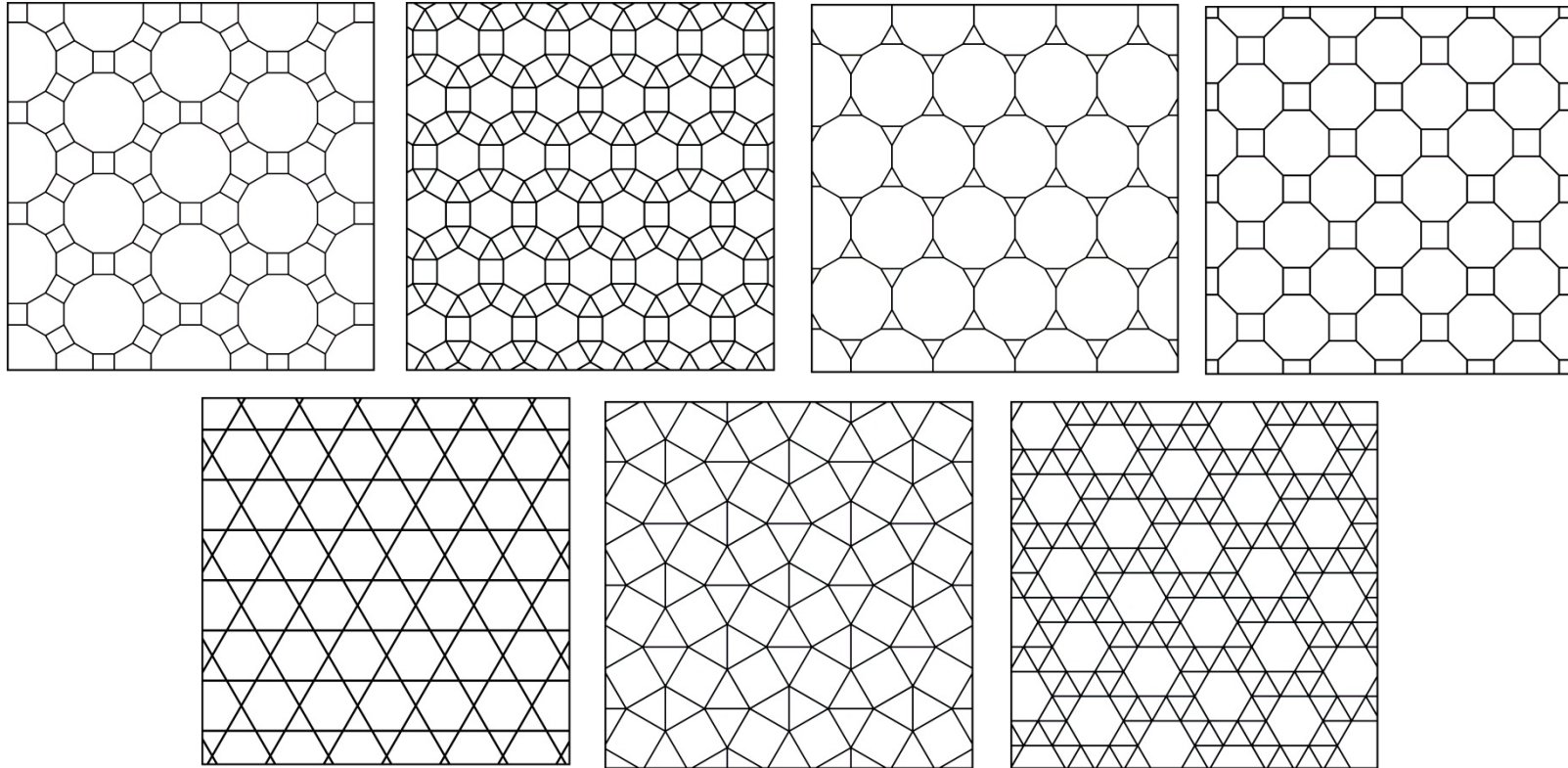

# CATALAN TILINGS

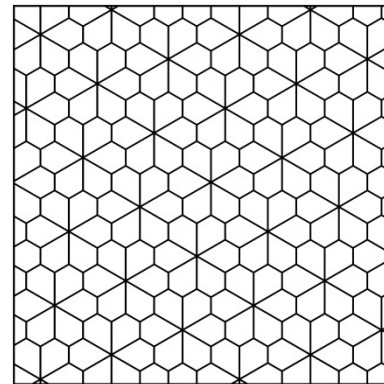
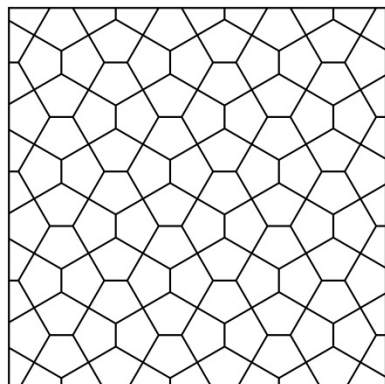
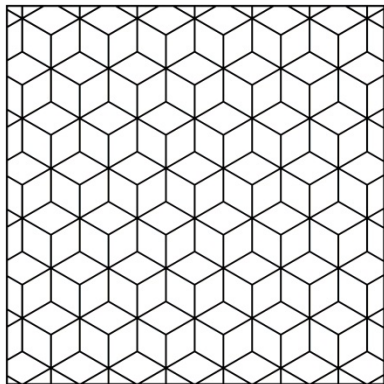
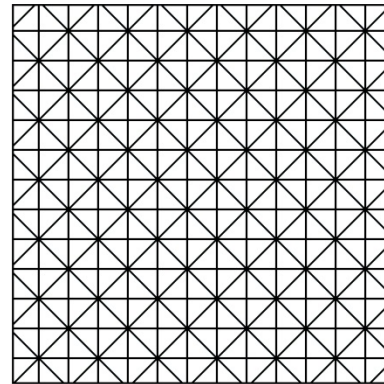
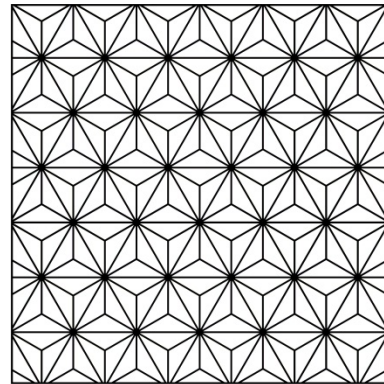
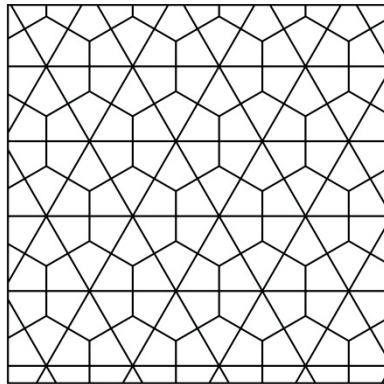
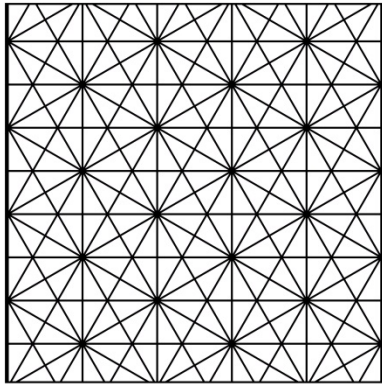

# APPLICATION: M. C. ESCHER



# APPLICATION: M. C. ESCHER



# APPLICATION: M. C. ESCHER





# APPLICATION: M. C. ESCHER



# APPLICATION: M. C. ESCHER

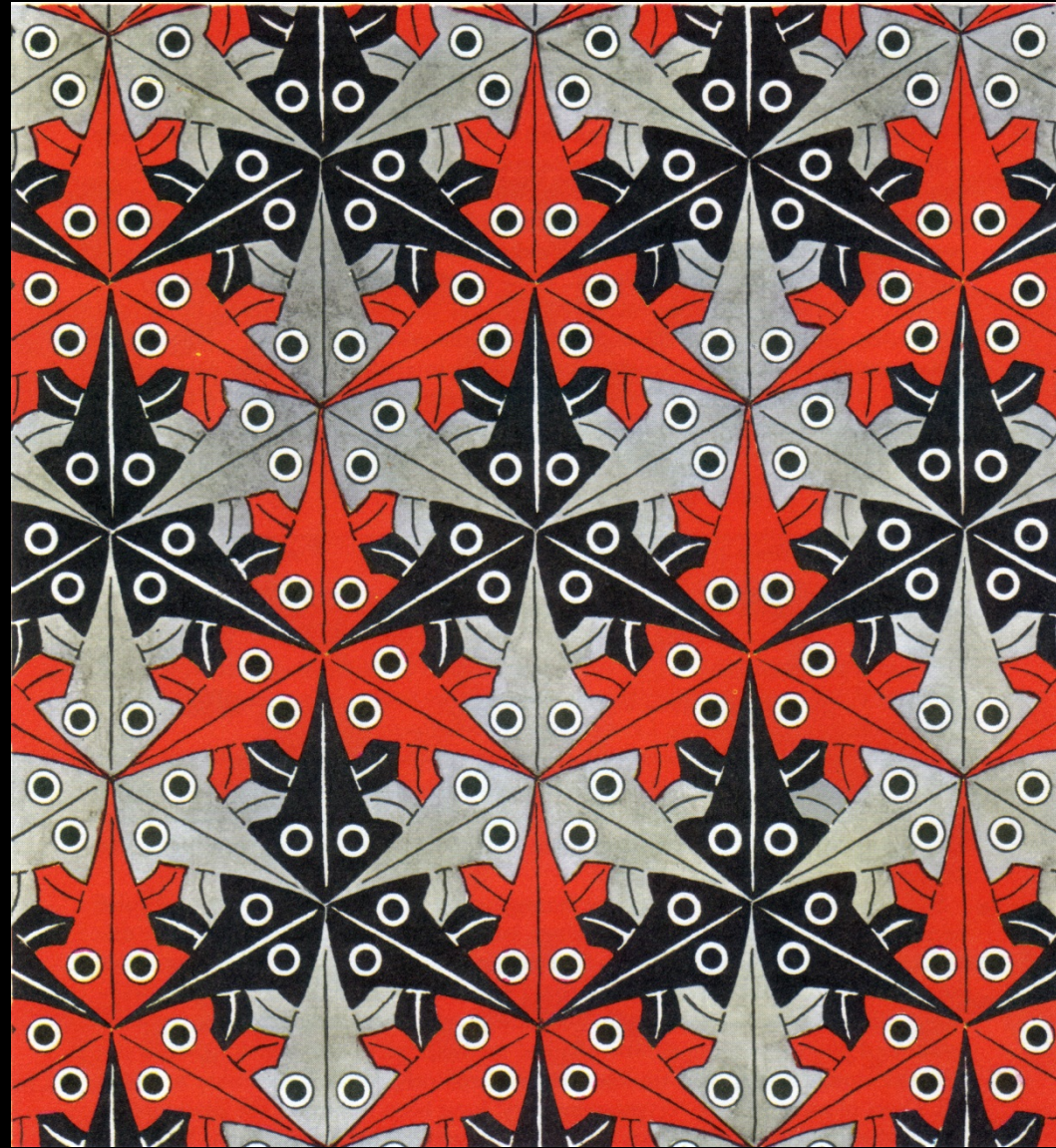

# APPLICATION: M. C. ESCHER

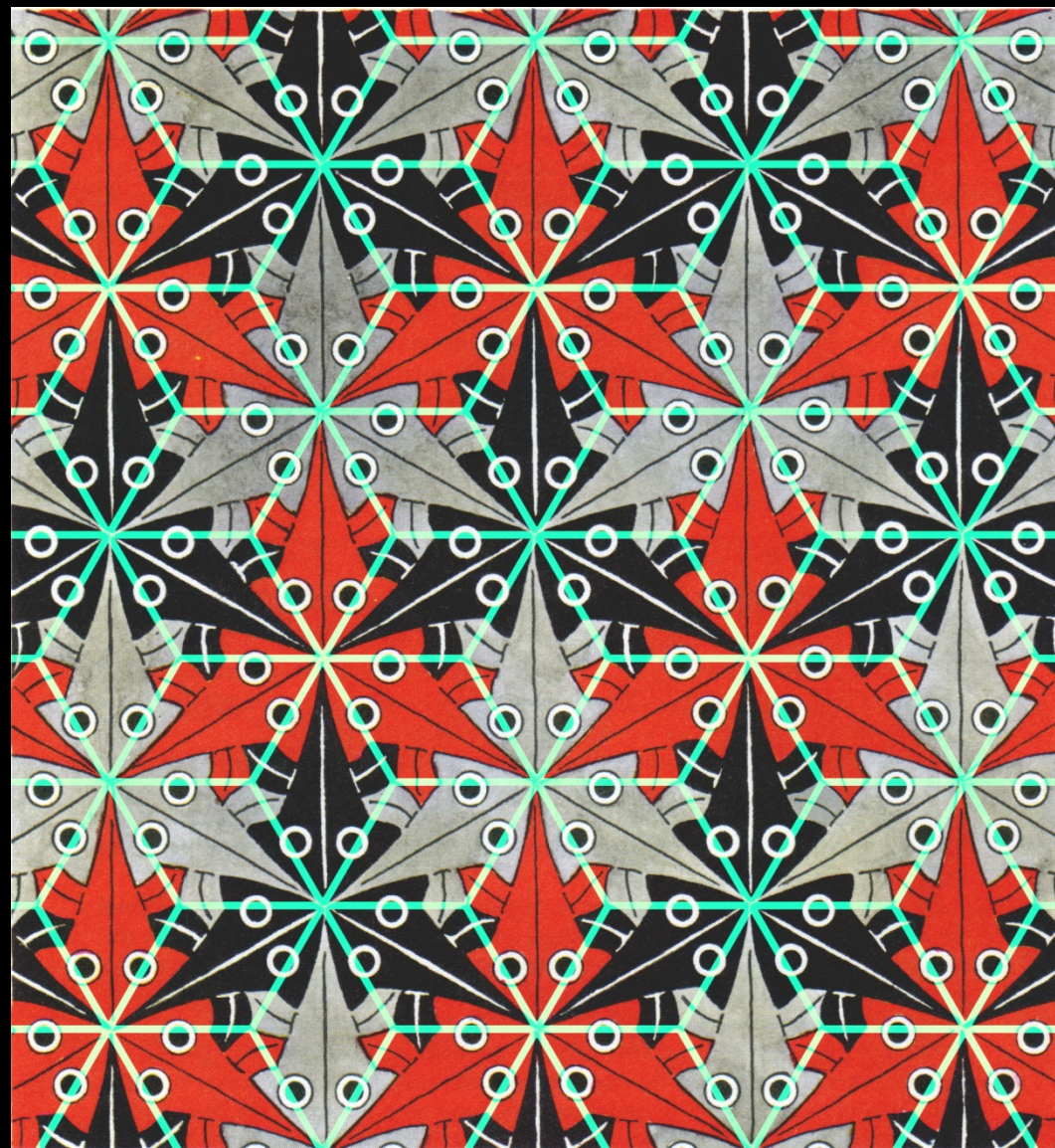

# APPLICATION: M. C. ESCHER



# APPLICATION: M. C. ESCHER



# APPLICATION: M. C. ESCHER

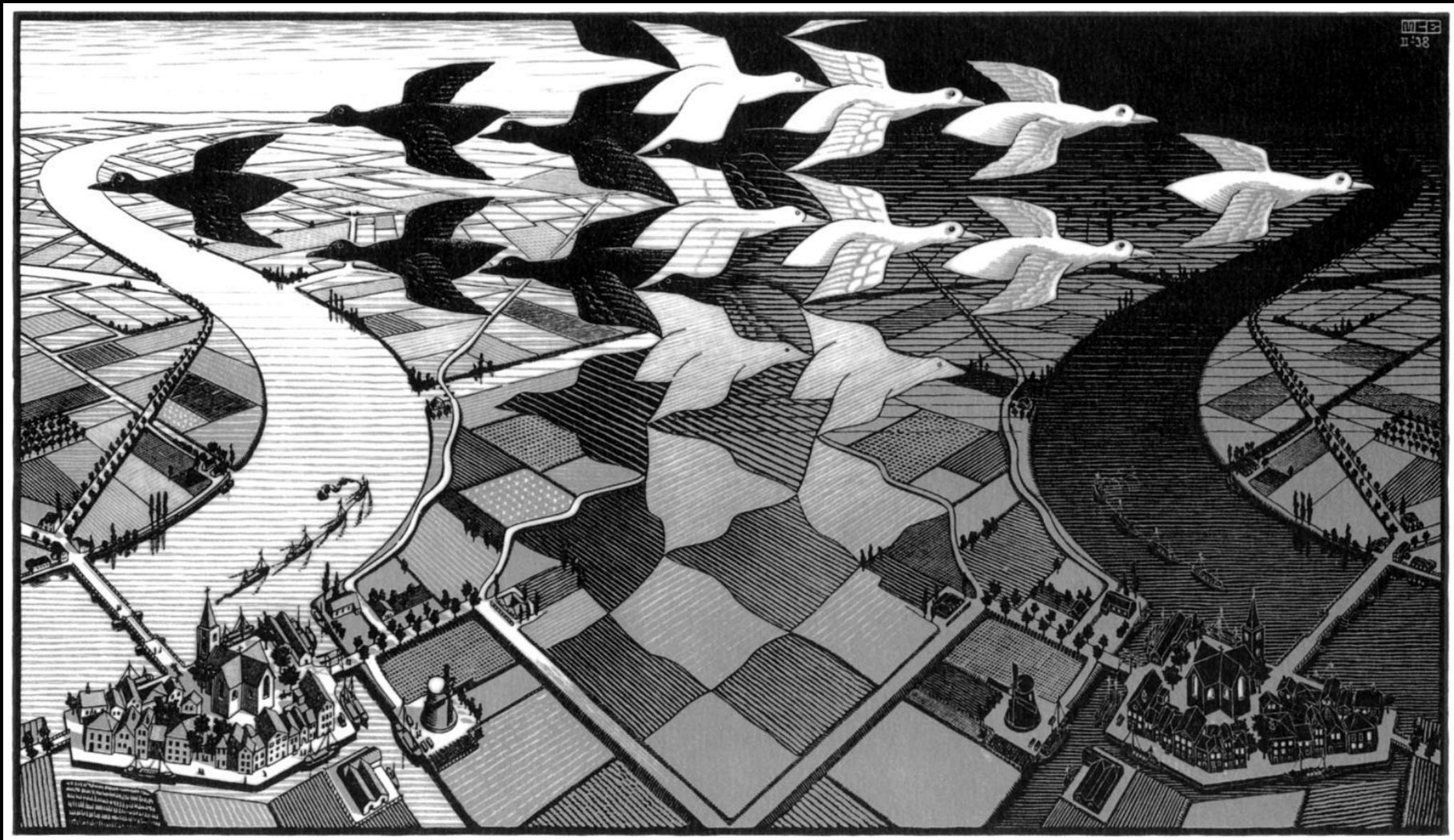

# APPLICATION: M. C. ESCHER



# APPLICATION: M. C. ESCHER

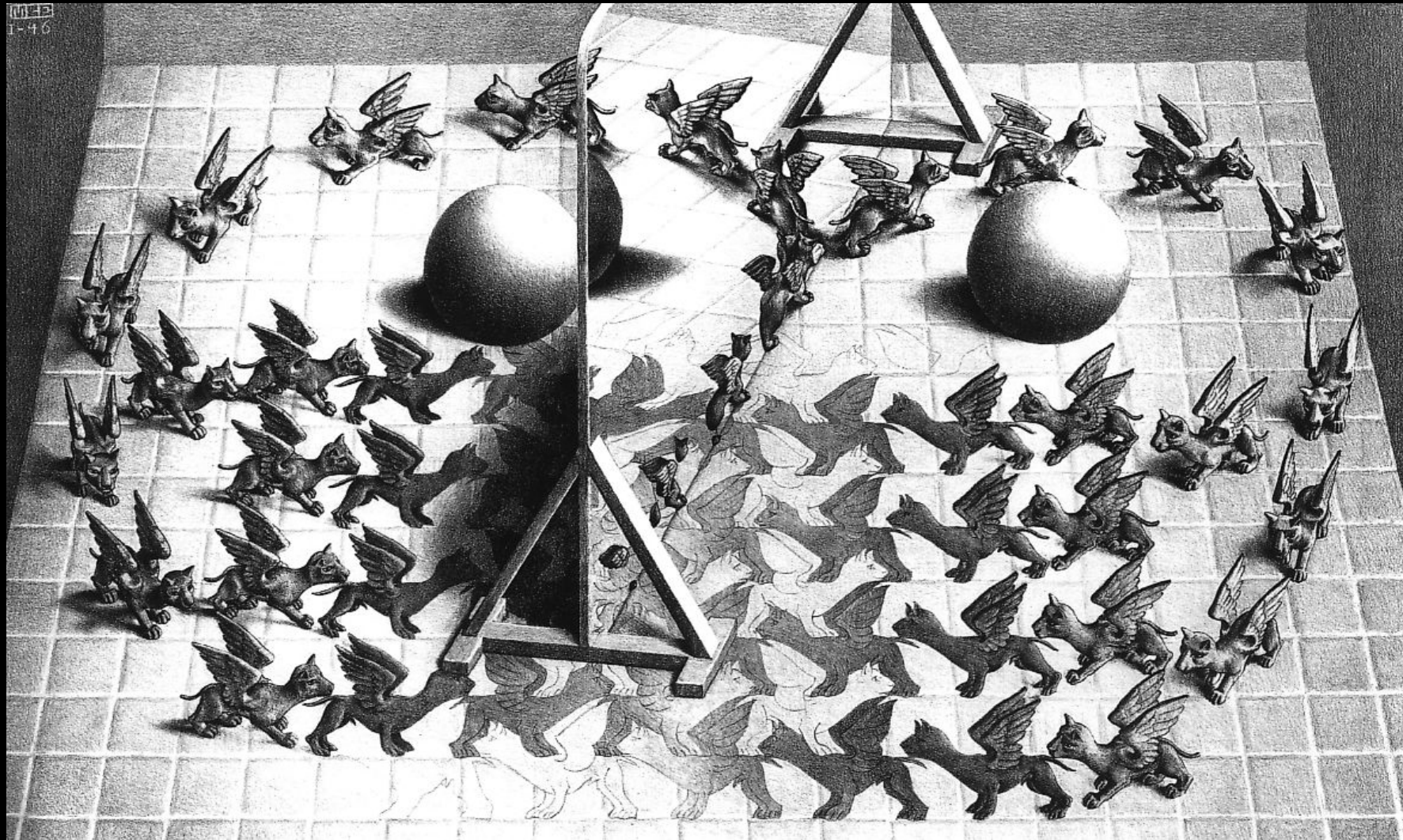



# APERIDIC TILINGS

Sir Roger Penrose: Kite & Dart

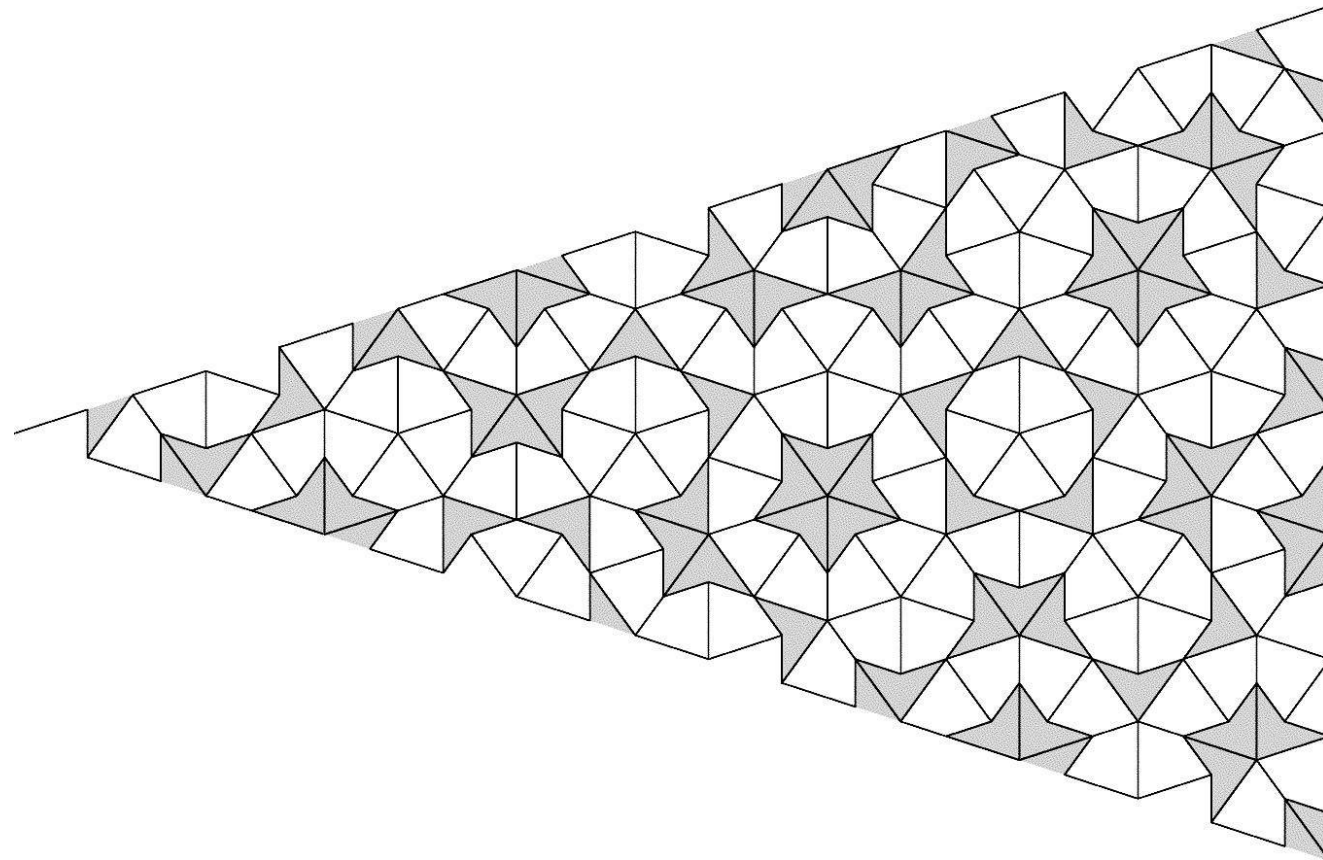

# APERIDIC TILINGS



# APERIDIC TILINGS

John Conway: Pinwheel tiling

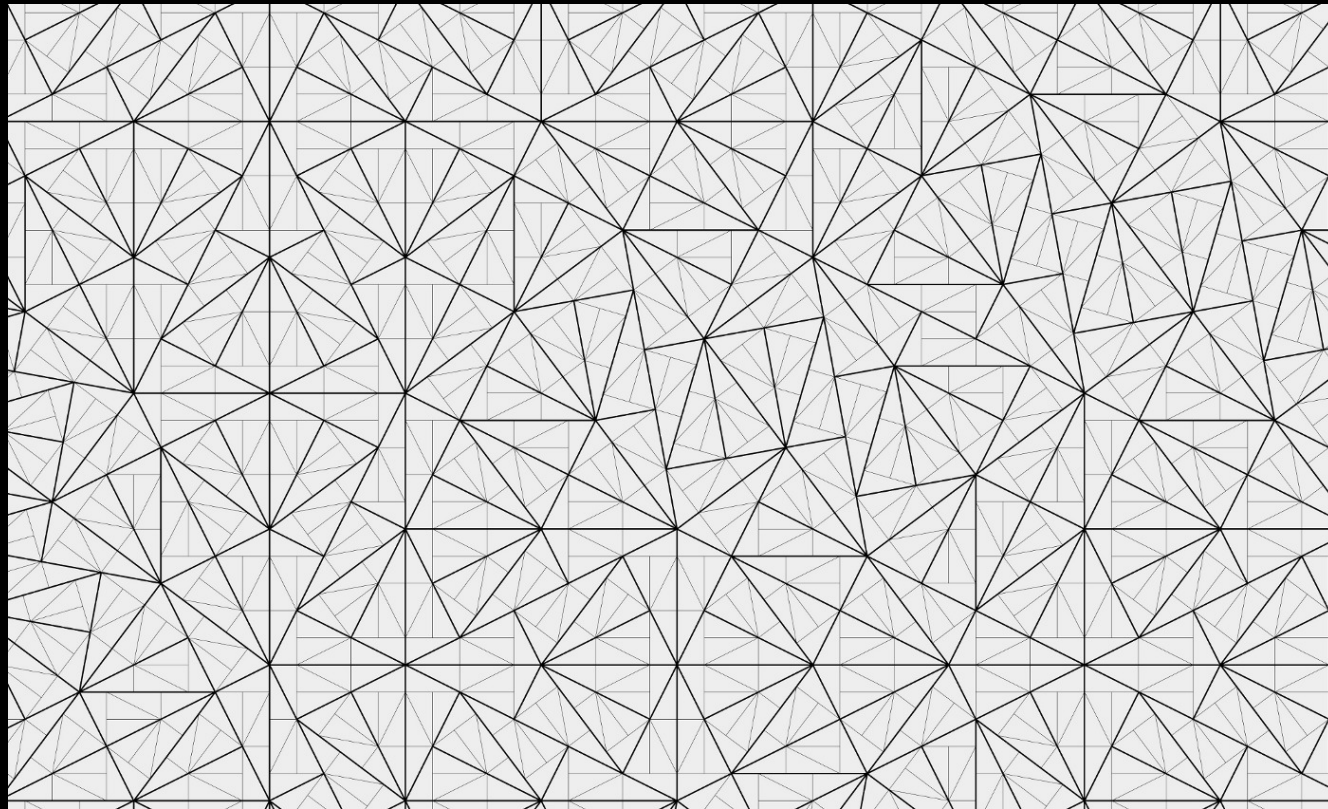

# APERIDIC TILINGS

Jouko Koskinen: Slim Pentagon

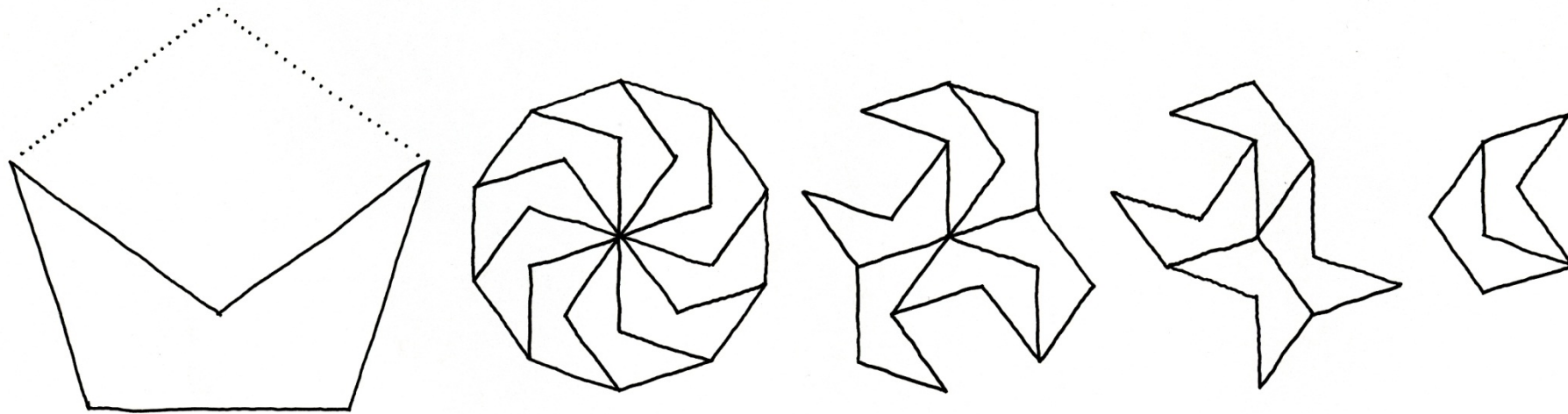

Polyhedra

# Platonic solids

Tetraedri

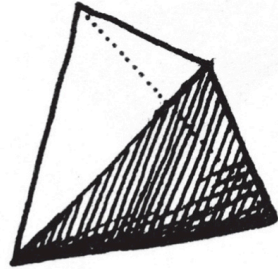

Kuutio

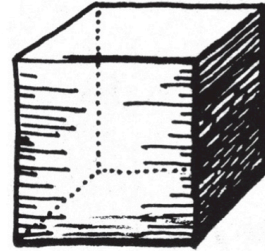

Oktaedri

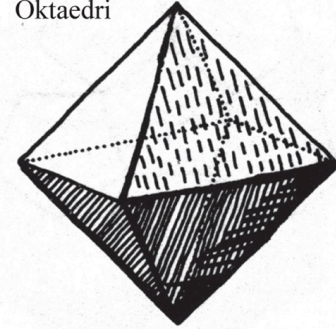

Dodekaedri

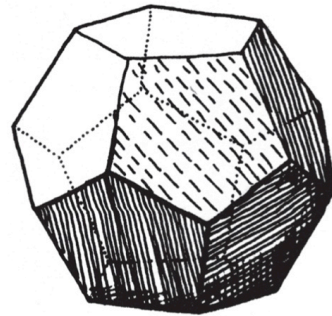

Ikosaedri

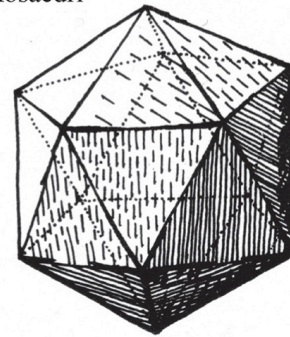

# Archimedean solids

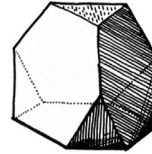

Tylpätty tetraedri

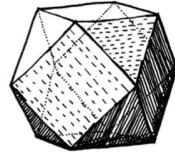

Kuboktaedri

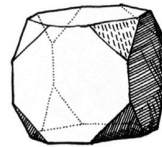

Tylpätty kuutio

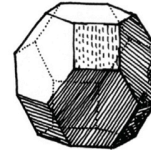

Tylpätty oktaedri

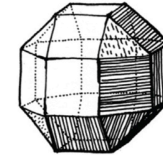

Rombikuboktaedri

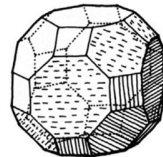

Rombitylpätty kuboktaedri

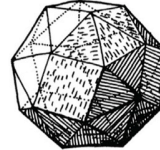

Kierä kuutio

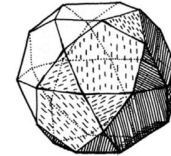

Ikosidodekaedri

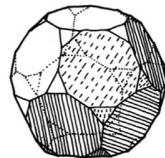

Tylpätty dodekaedri

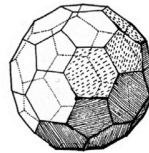

Tylpätty ikosaedri

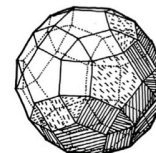

Rombi-  
ikosidodekaedri

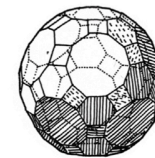

Tylpätty  
ikosidodekaedri

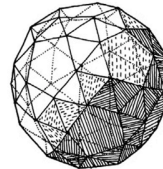

Kierä  
dodekaedri

# Catalan solids

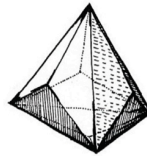

Triakis  
tetraedri

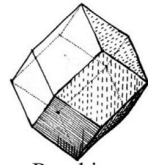

Rombinen  
dodekaedri

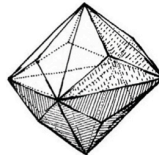

Triakis  
oktaedri

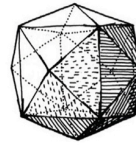

Tetrakis  
kuutio

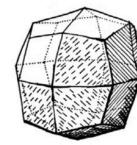

Nelikulmioinen  
ikositetraedri

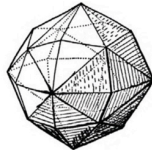

Heksakis  
oktaedri

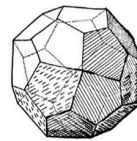

Viisikulmioinen  
ikositetraedri

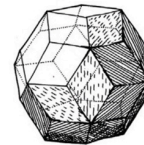

Rombinen  
triakontaedri

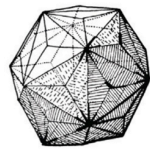

Triakis  
ikosaedri

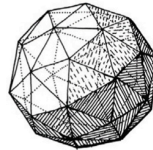

Pentakis  
dodekaedri

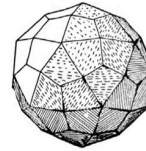

Nelikulmioinen  
heksekontaedri

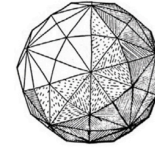

Heksakis  
ikosaedri

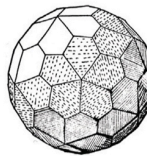

Viisikulmioinen  
heksekontaedri





# Neolithic stones

Scotland, circa 2000 BCE.

# Platon: *Timaios* 360 BCE.

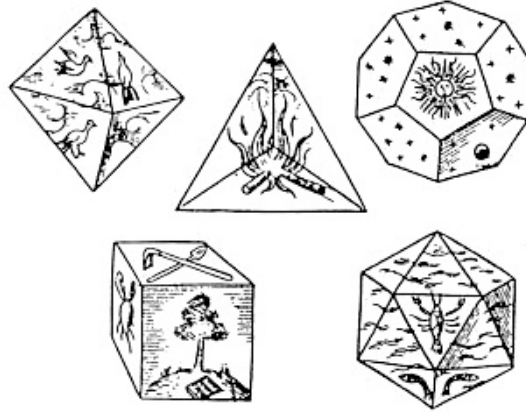

Octahedron - Air

Tetrahedron – Fire

Cube - Earth

Icosahedron - Water

Dodecahedron - Universe

# Roman dice

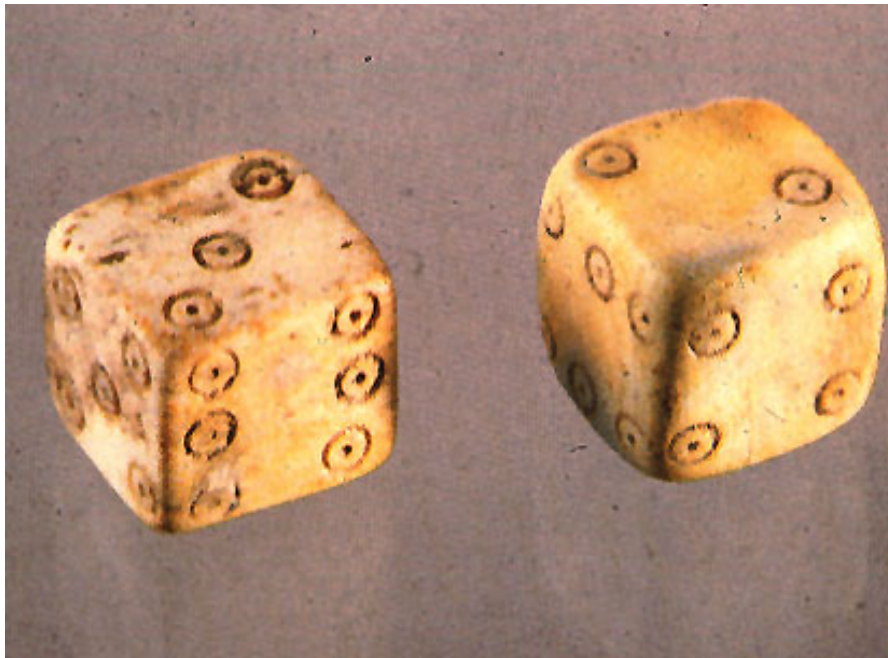

Ivory



Stone

# Roman dodecahedra

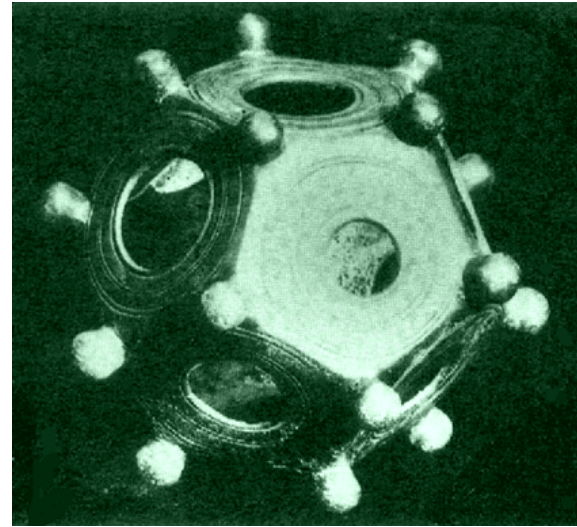

Bronze

# Roman icosahedron

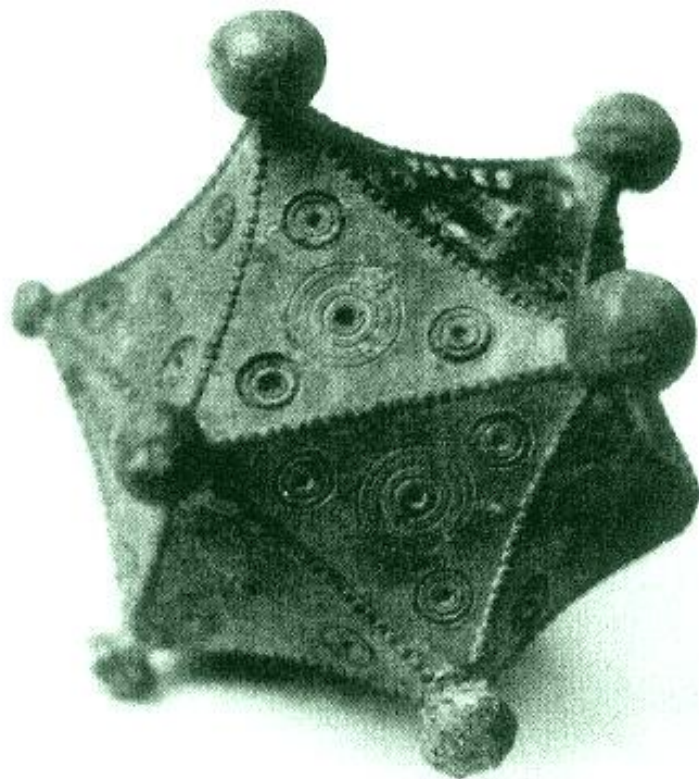

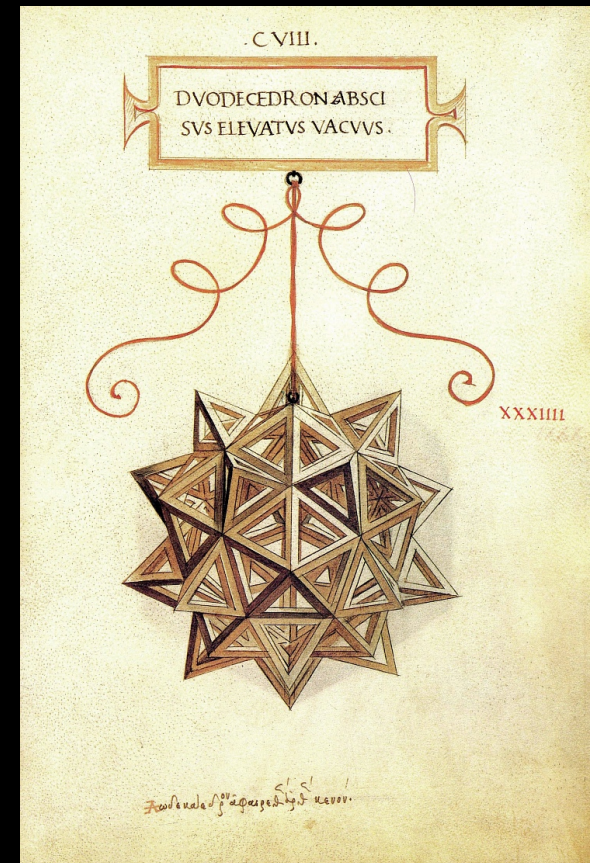
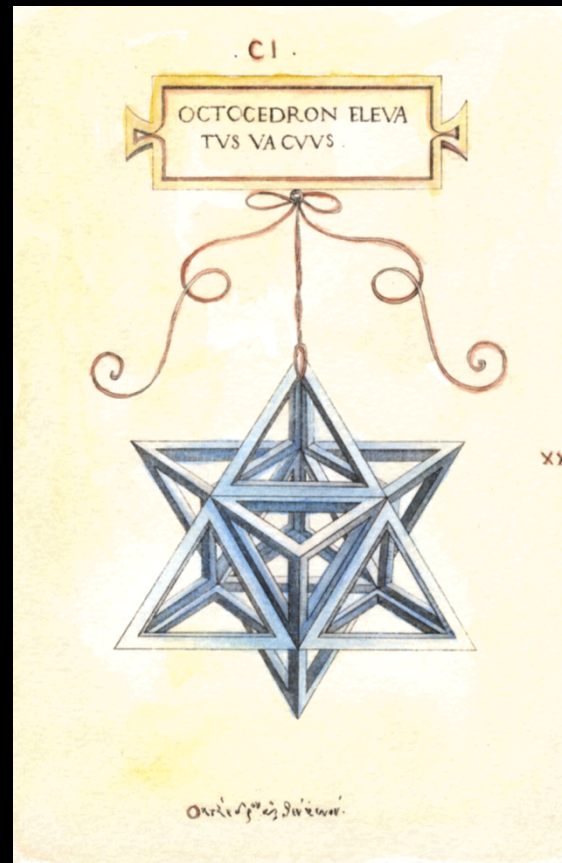
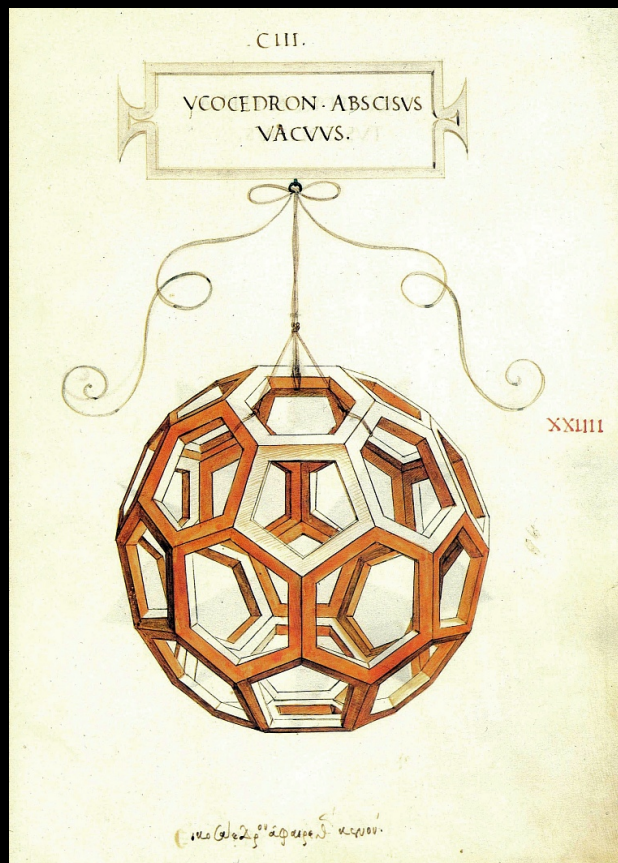

Leonardo da Vinci in Luca Pacioli's "The Divine Proportion", 1509



Albert Dürer: "Melancholia I", 1514

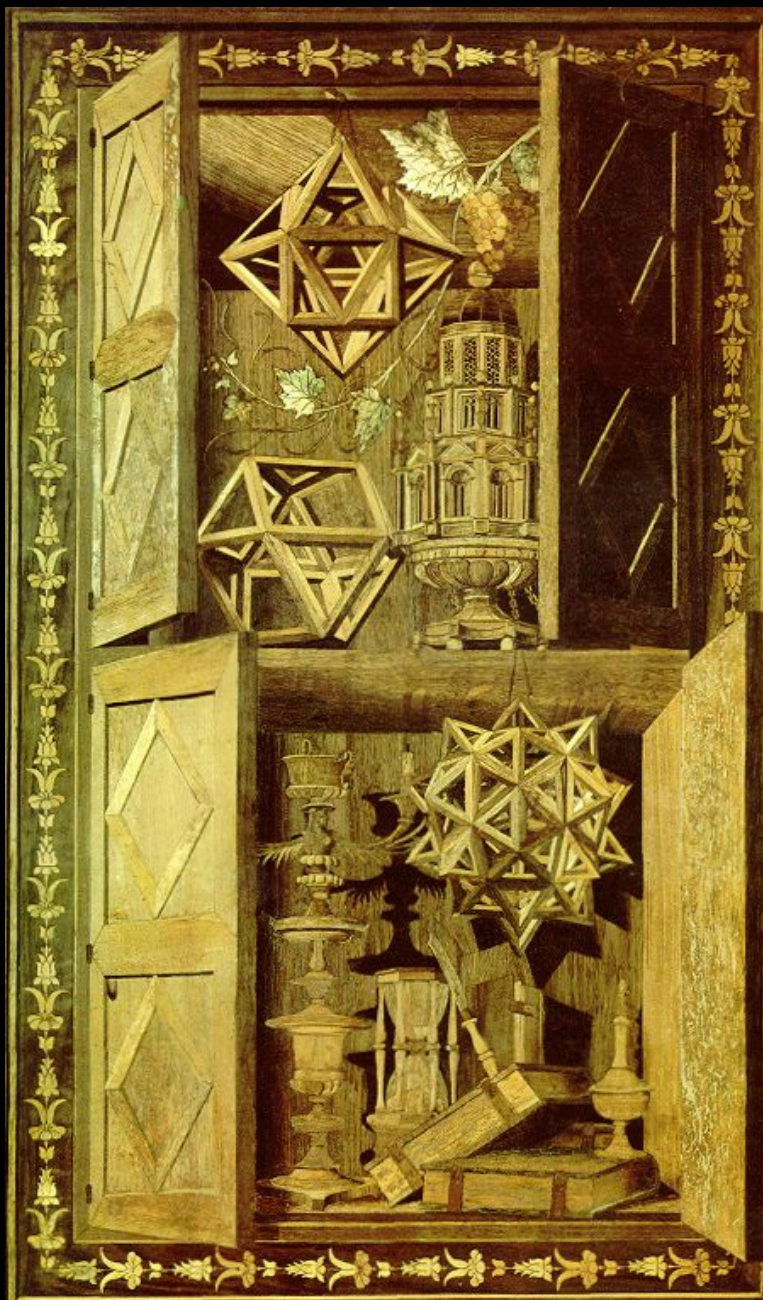

Intarsia by Fra Giovanni da Verona, c. 1520



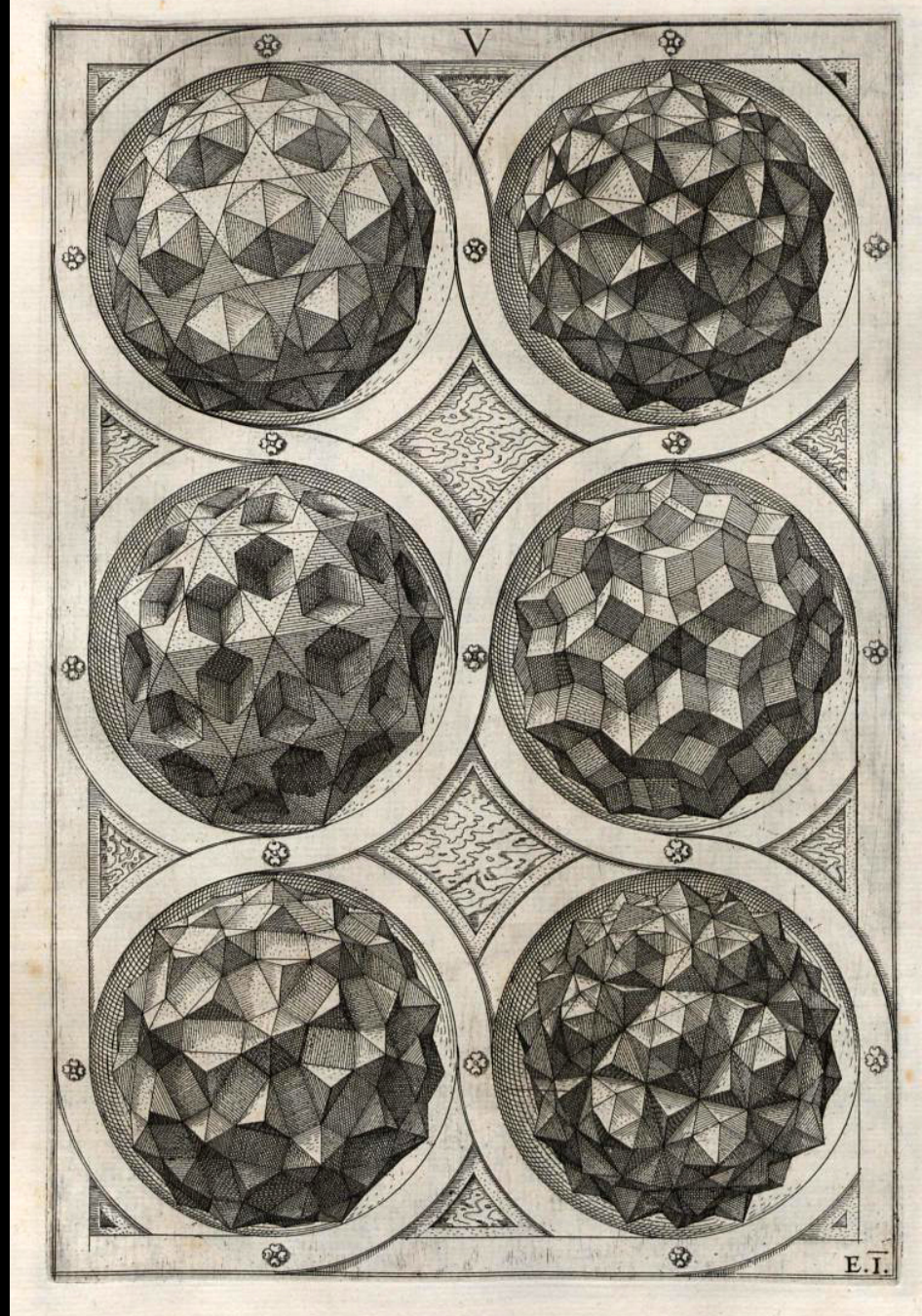

Wenzel Jamnitzer: "Perspectiva Corporum Regularium", 1568

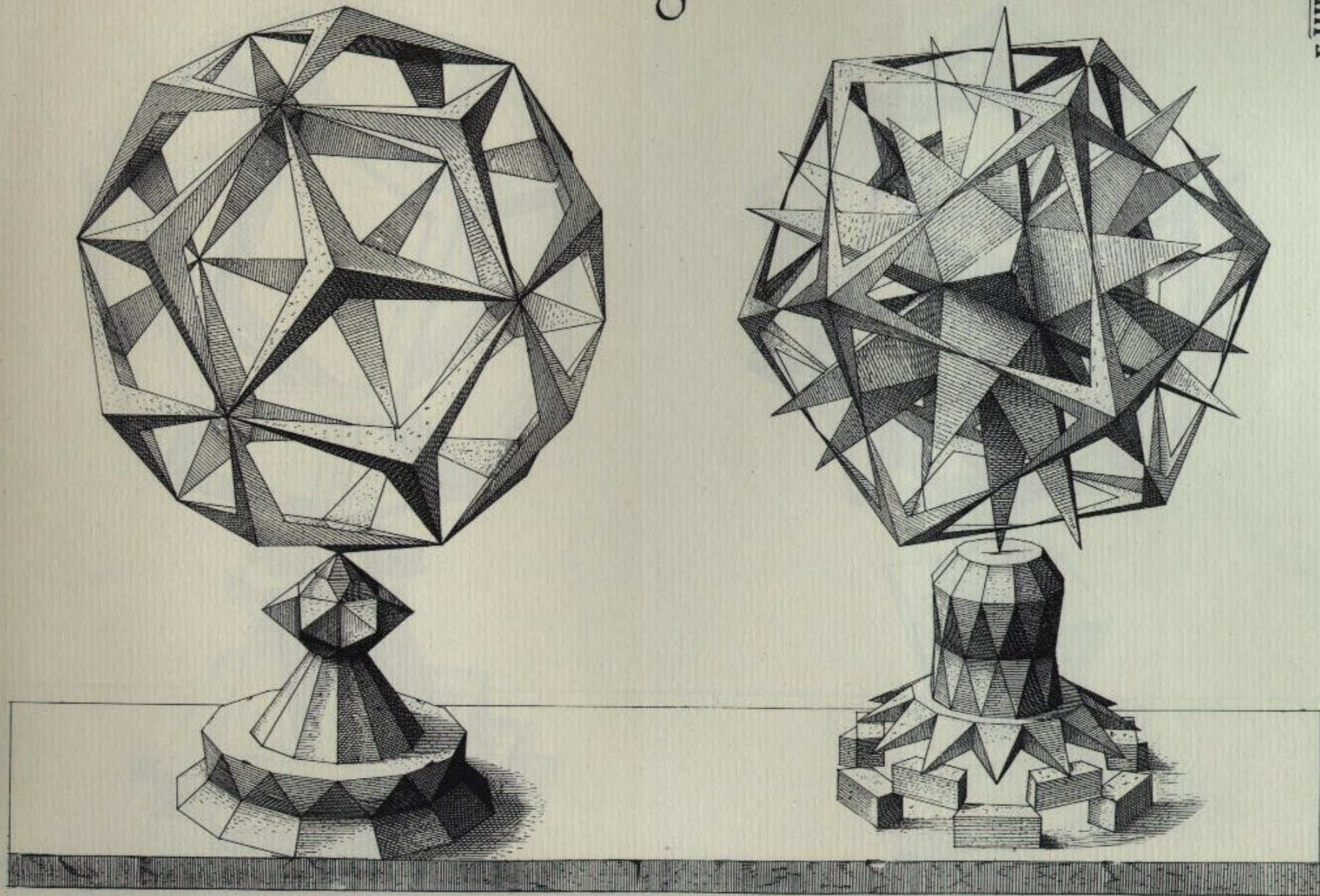

Wenzel Jamnitzer: "Perspectiva Corporum Regularium", 1568



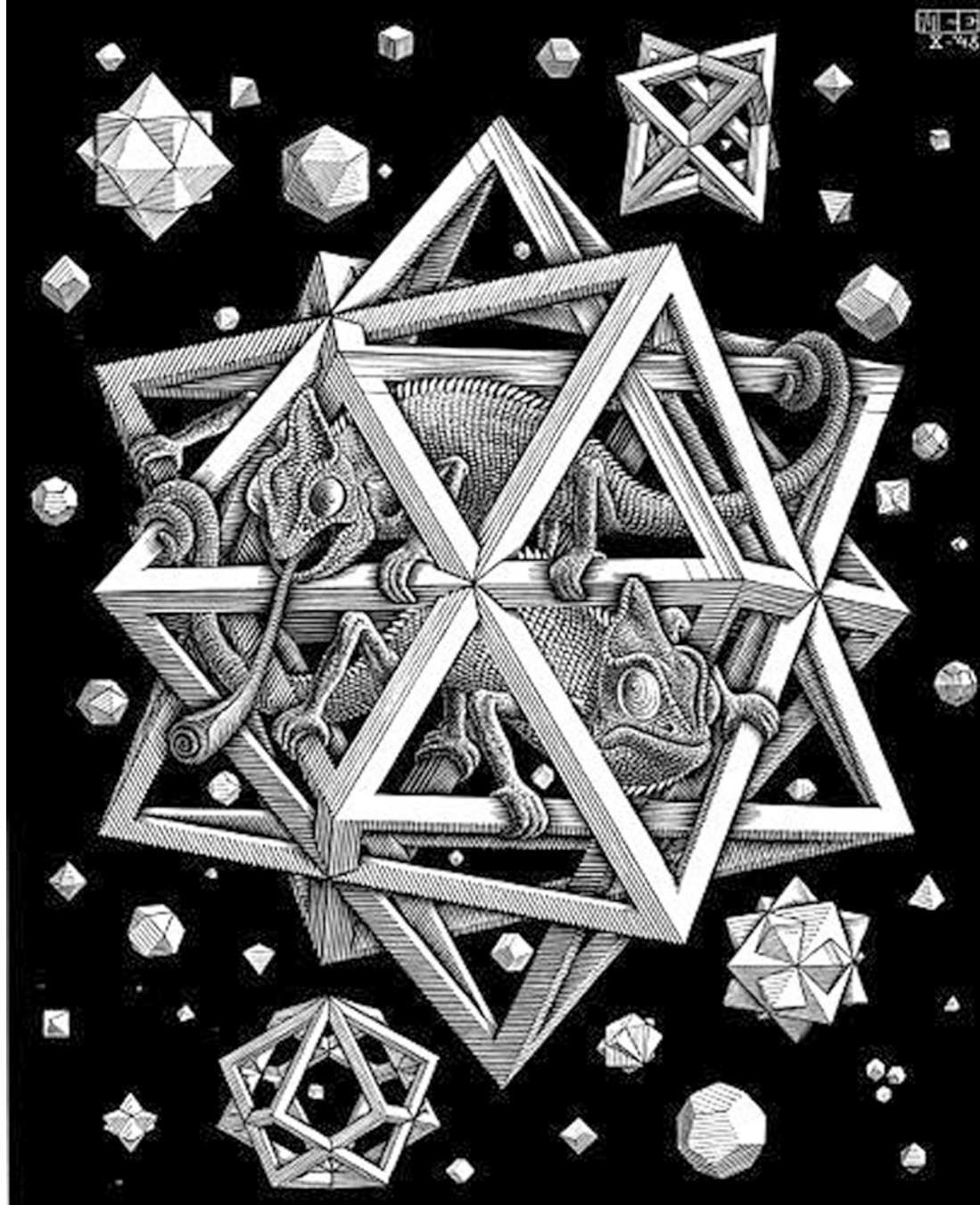

M. C. Escher: "Stars", 1948

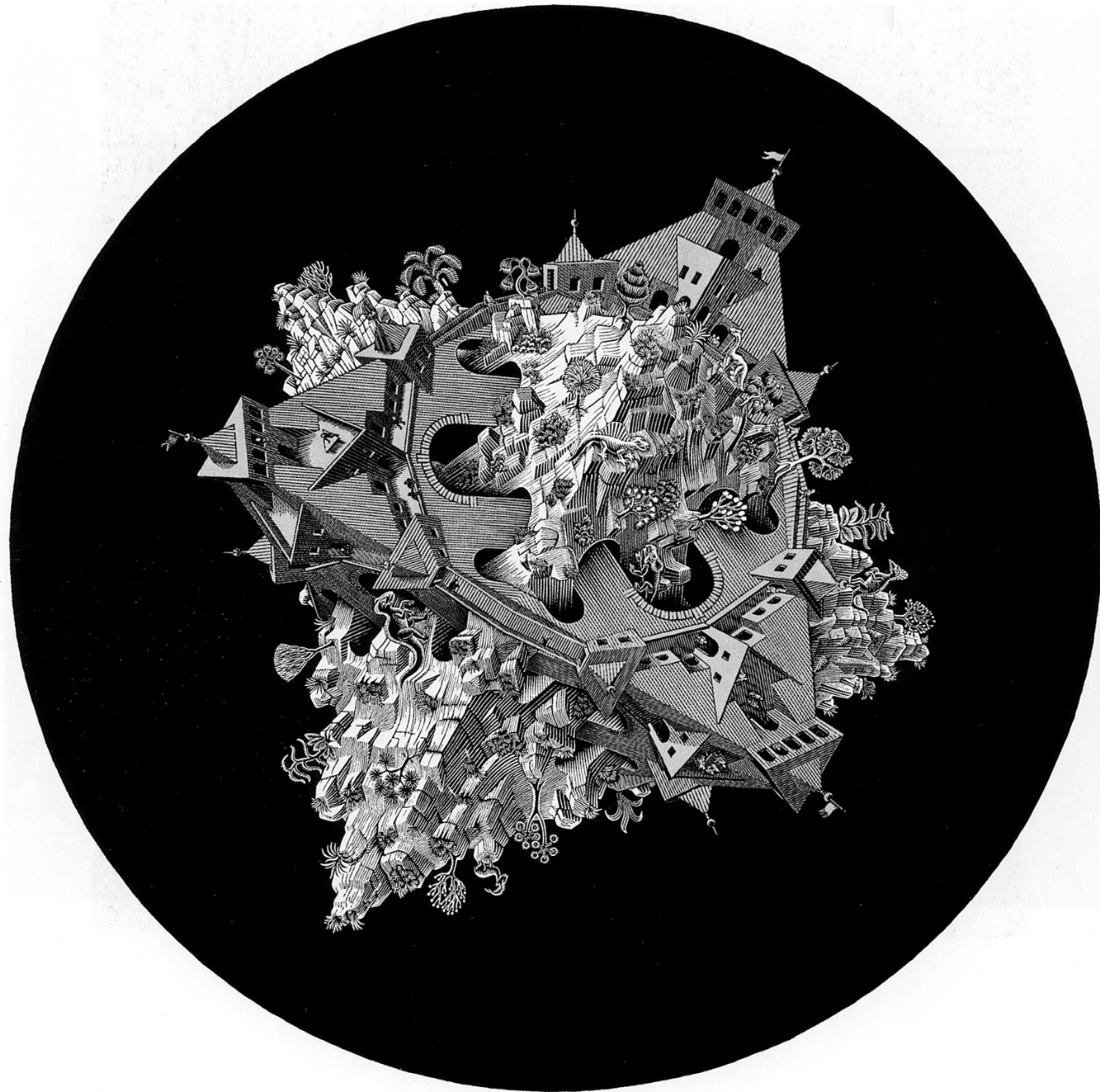

M. C. Escher: "Double planetoid", 1949



M. C. Escher: "Gravitation", 1952



Charles O. Perry: "Eclipse", 1973

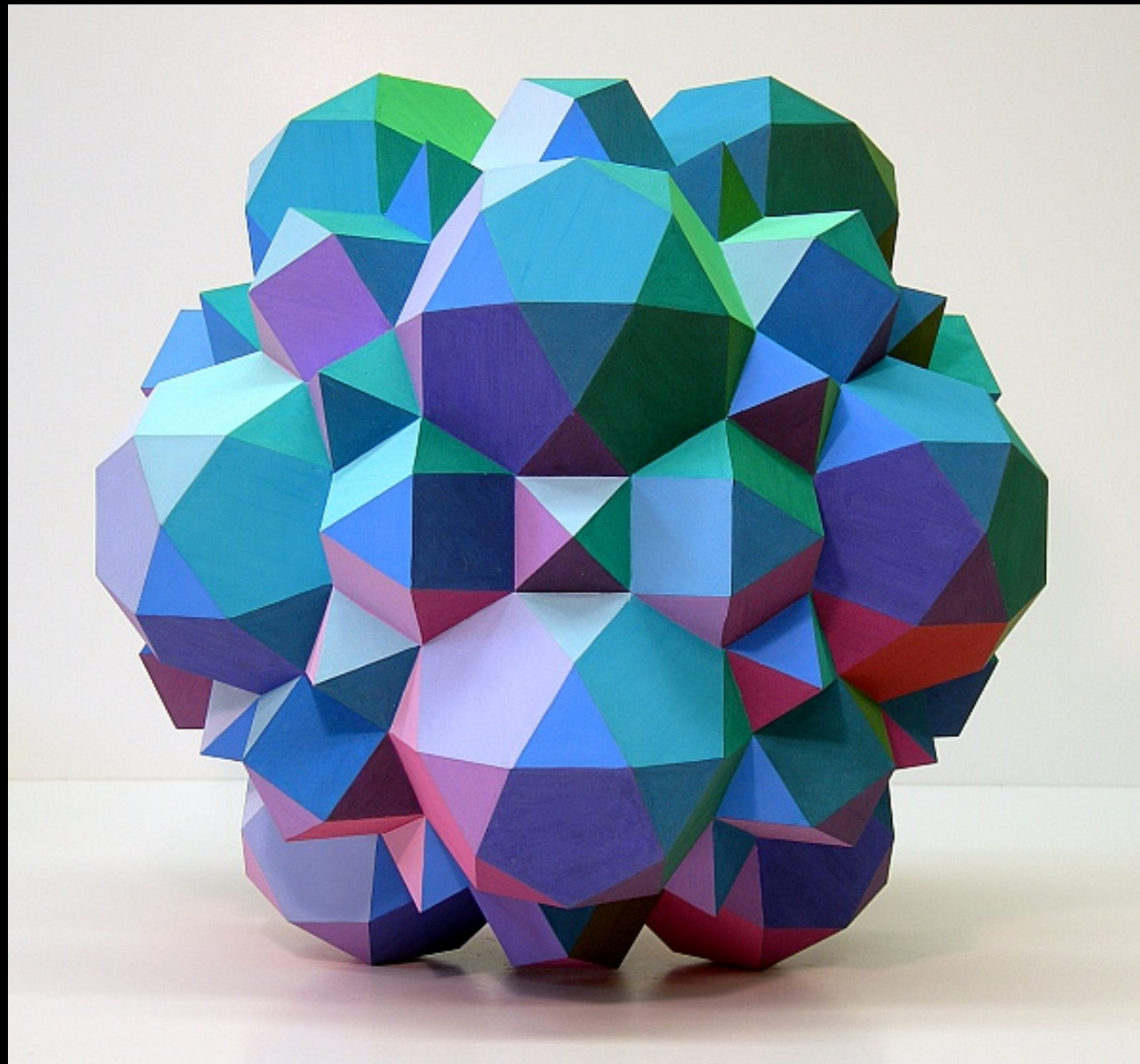

Morton J. Bradley Jr.: "Archimedes"



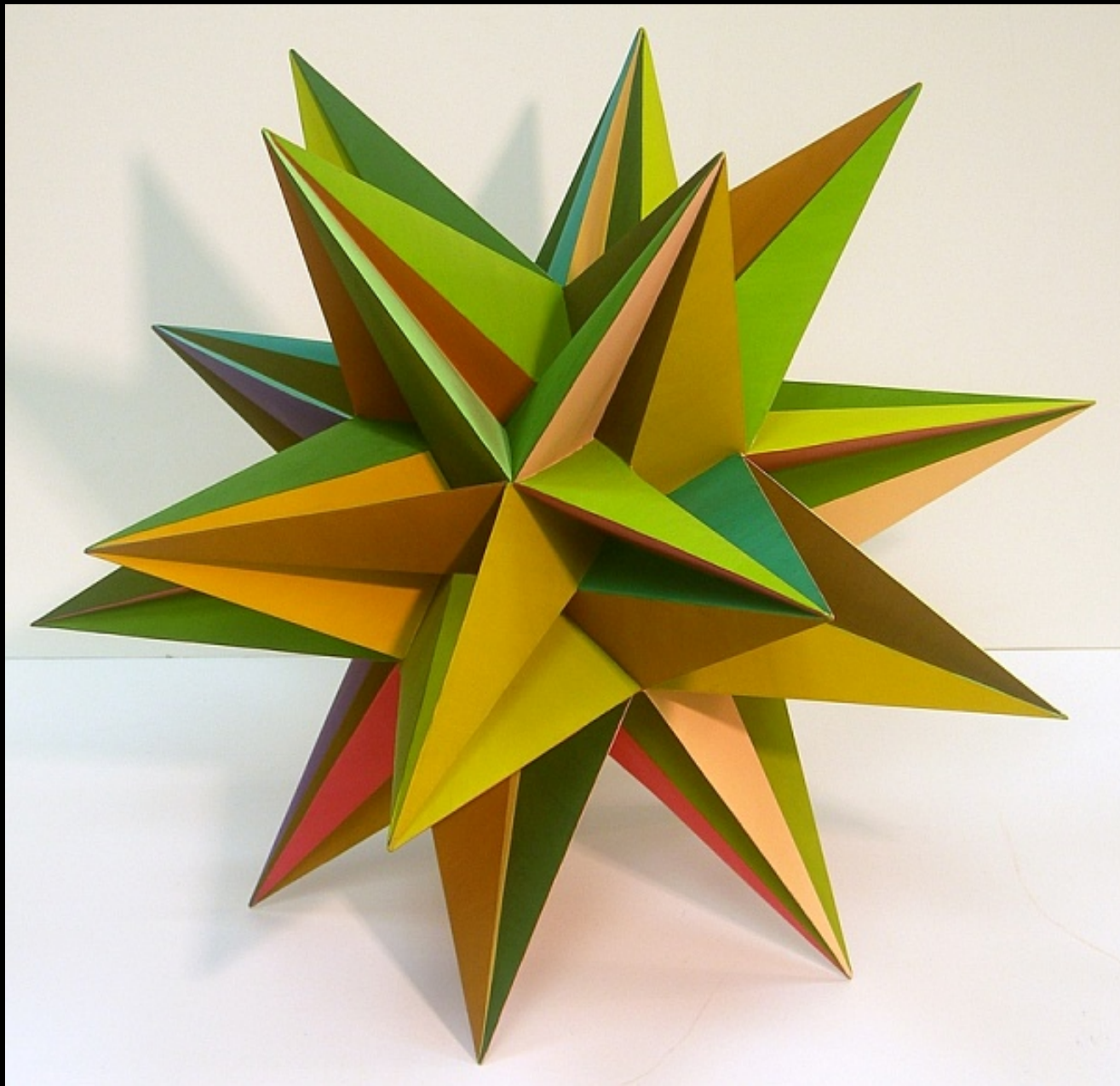

Morton J. Bradley Jr.: "Harlequin"



Morton J. Bradley Jr.: "Untitled", 1971



Morton J. Bradley Jr.: "Untitled", 1977



George Hart: "Battered Moonlight"



George Hart: "Whoville"



George Hart: "Gazmogenesis"



Goerge Hart: "72 pencils"



Buckminster Fuller: Geodesic dome





Eden Project: Geodesic domes

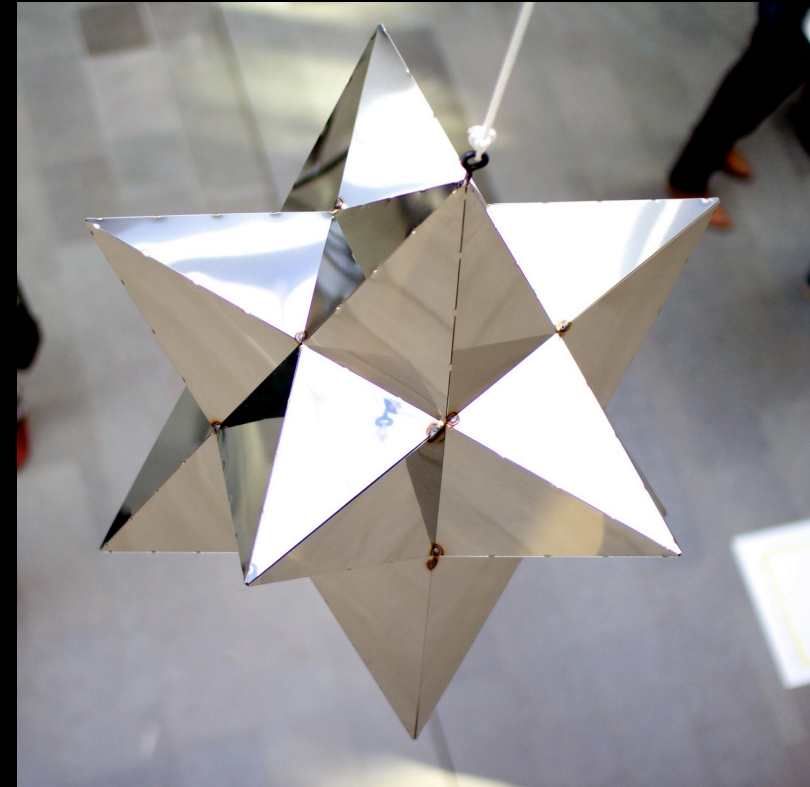

Hietaniemi, Jaakkola, Klemettinen, Laine, Laurila: "Diving Solids", 2013



Häkkinen, Kivinen, Lindström, Mikkola, Norri: "Modern Vitruvian Man", 2013



George Hart & students: "Aalto Sculptures", 2013



Conrad Shawcross: "Portrait", 2008



Conrad Shawcross: "Portrait", 2008



Conrad Shawcross: "Portrait", 2008

Plastic bag dodecahedron:

<http://www.youtube.com/watch?v=x7Xq4OX7beU>



# Hyperbolic geometry

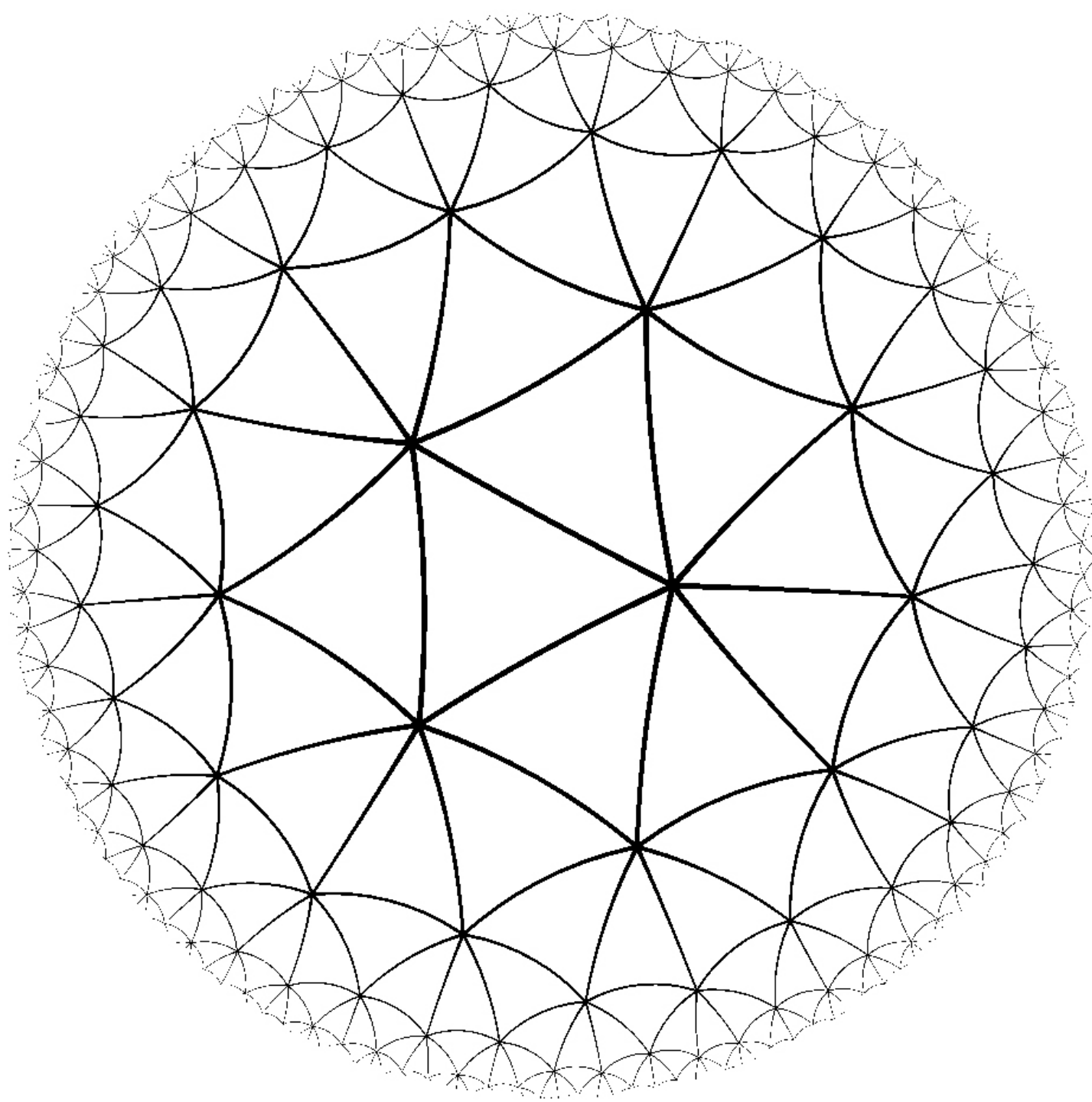

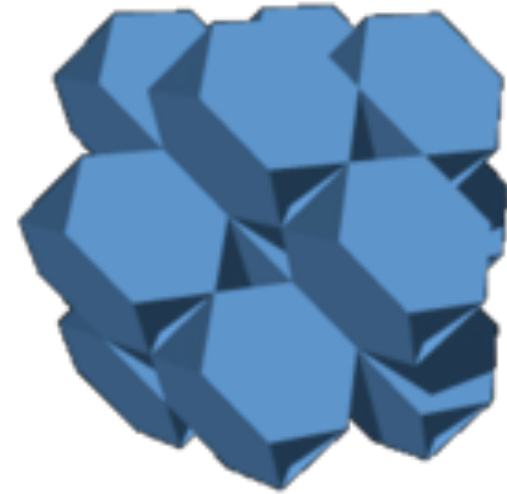
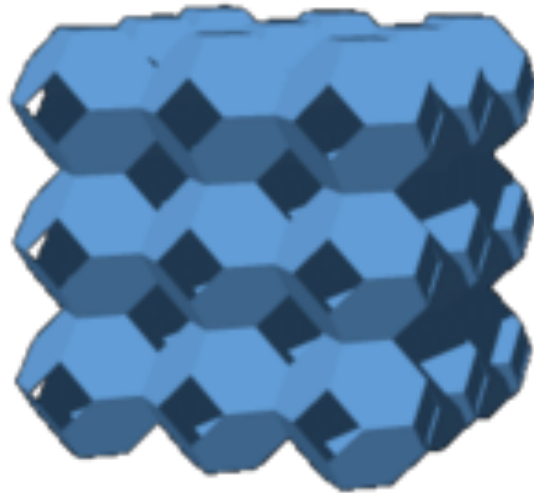
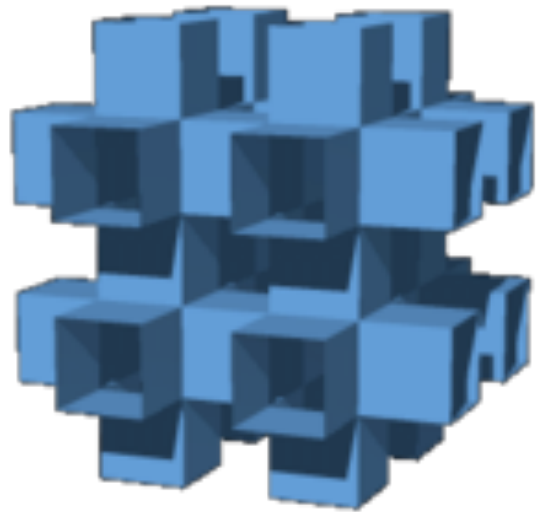

”Regular skew apeirohedron”



M. C. Escher: Circle Limit I (1958)

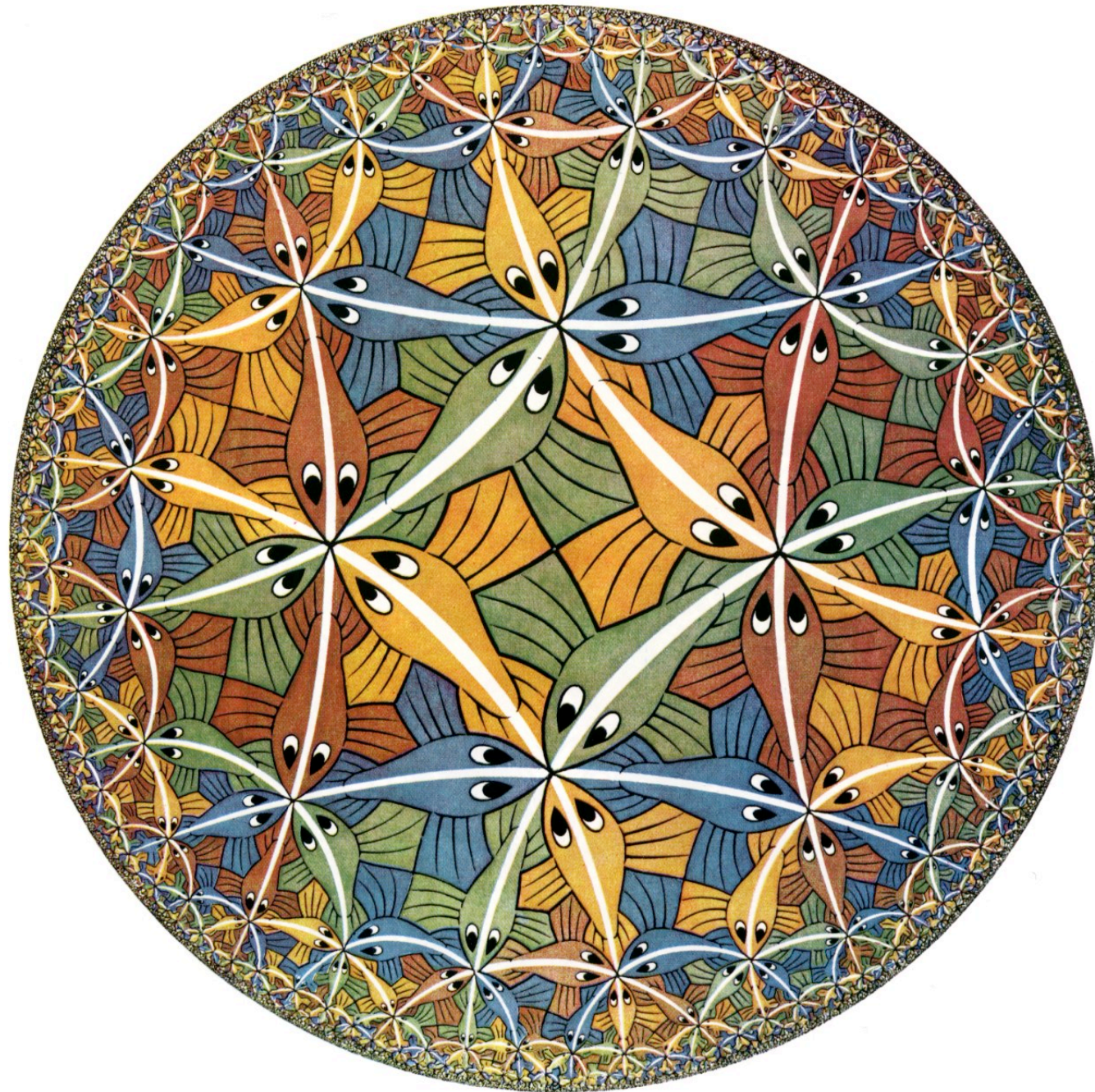

M. C. Escher: Circle Limit III (1959)



Institute For Figuring: "Hyperbolic Crochet Coral Reef"



Institute For Figuring: "Hyperbolic Crochet Coral Reef"

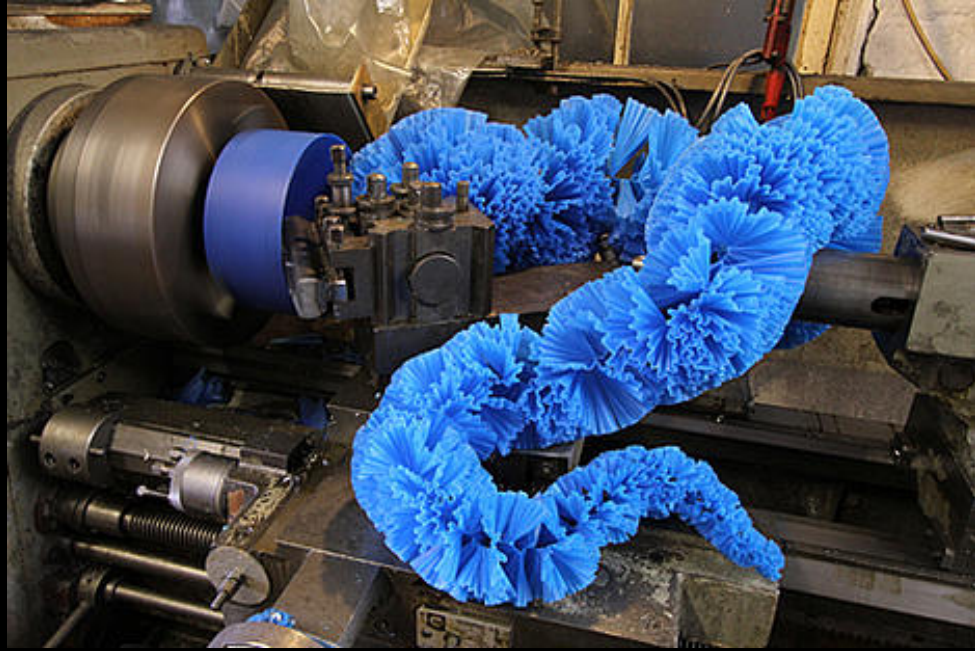

Conrad Shawcross: “Hyperbolic Swarf Drawings”



Perspective



"Madonna della Misericordia", fresco, 1352



“Chain Map”, puupiiirros, n.1471-82



Giotto: "Exorcism of the Demons", 1299



Giotto: "Expulsion of Joachim from the Temple", 1313



Filippo Brunelleschi (1377–1446)



Piazza del Duomo, Firenze

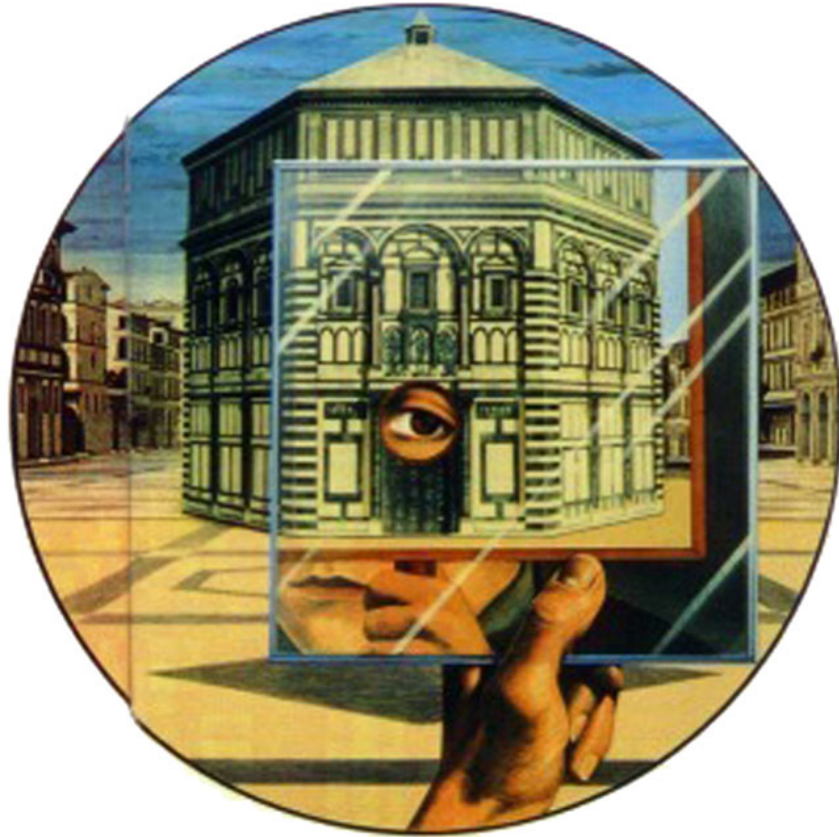

Brunelleschi's first perspective experiment, circa 1420





Ptolemaios, "Geographia" circa 150 (14<sup>th</sup> century copy)



Leon Battista Alberti (1404–1472)

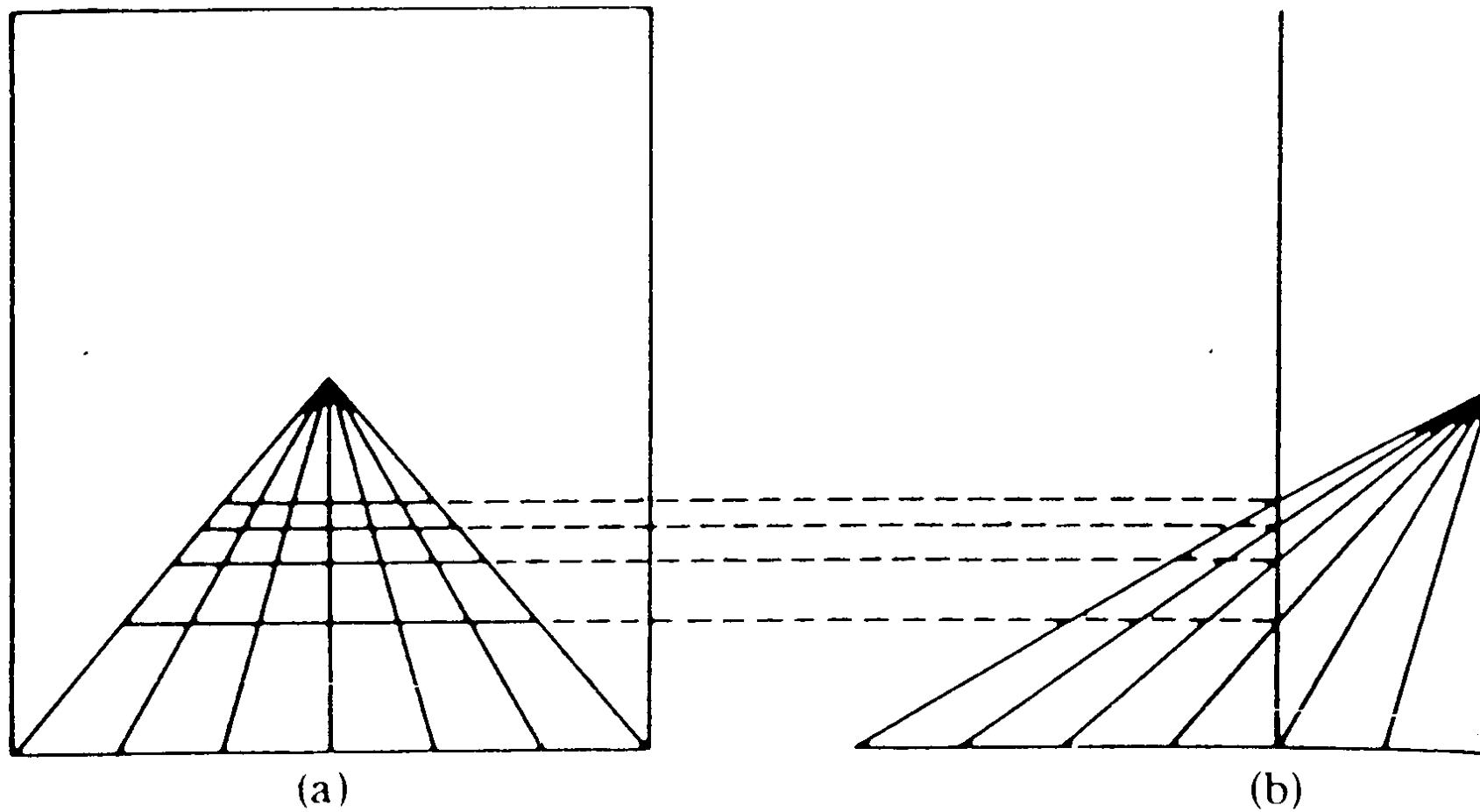

Alberti's 'distance point' method, "Della Pittura", 1435

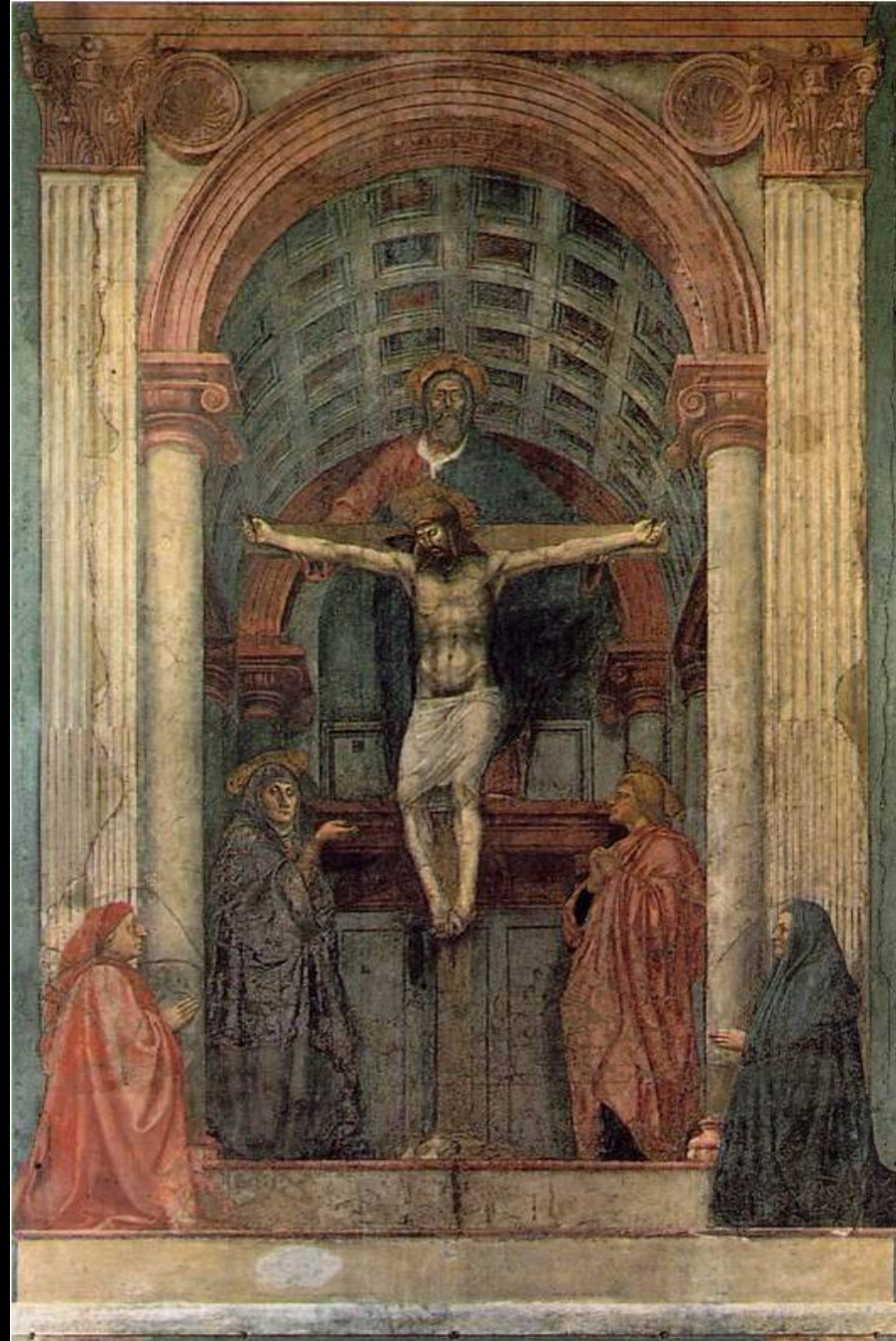

Masaccio: "Holy Trinity", n. 1427

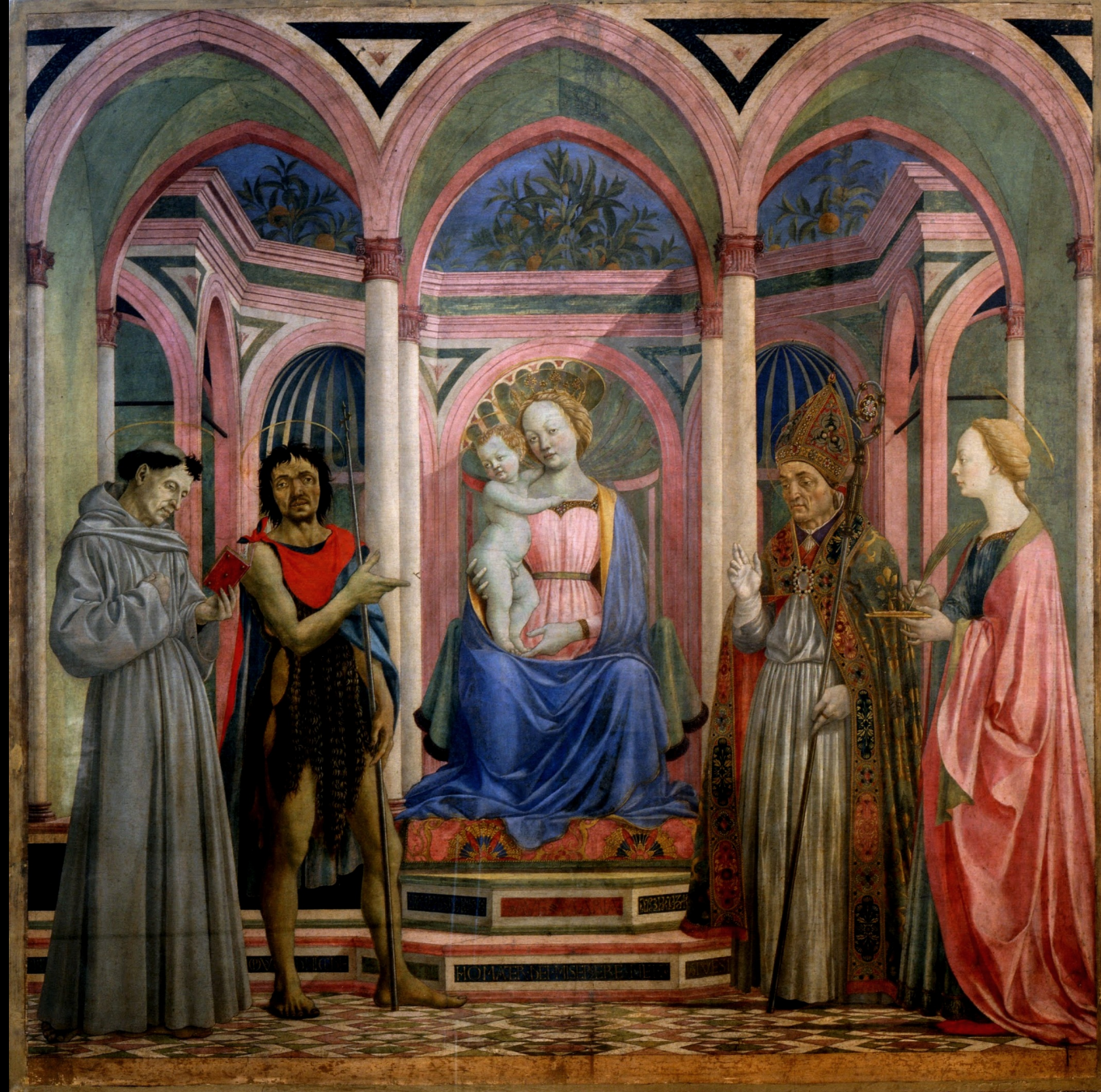

Domenico Veneziano: "Madonna and Child Enthroned with Standing Saints", n. 1445

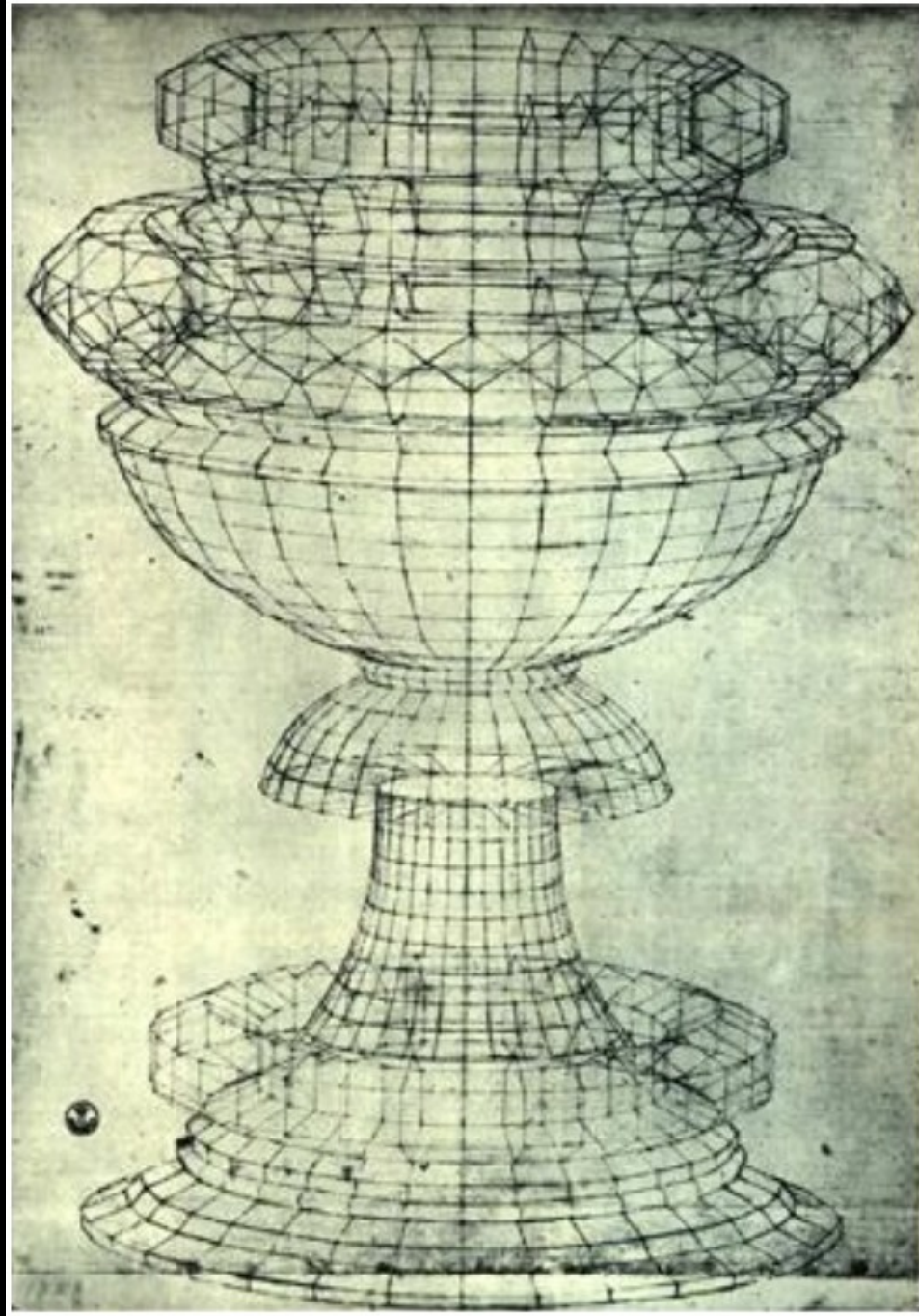

Paolo Uccello: "Perspective Study of a Chalice", n. 1430



Paolo Uccello: "The Battle of San Romano", n. 1438-40

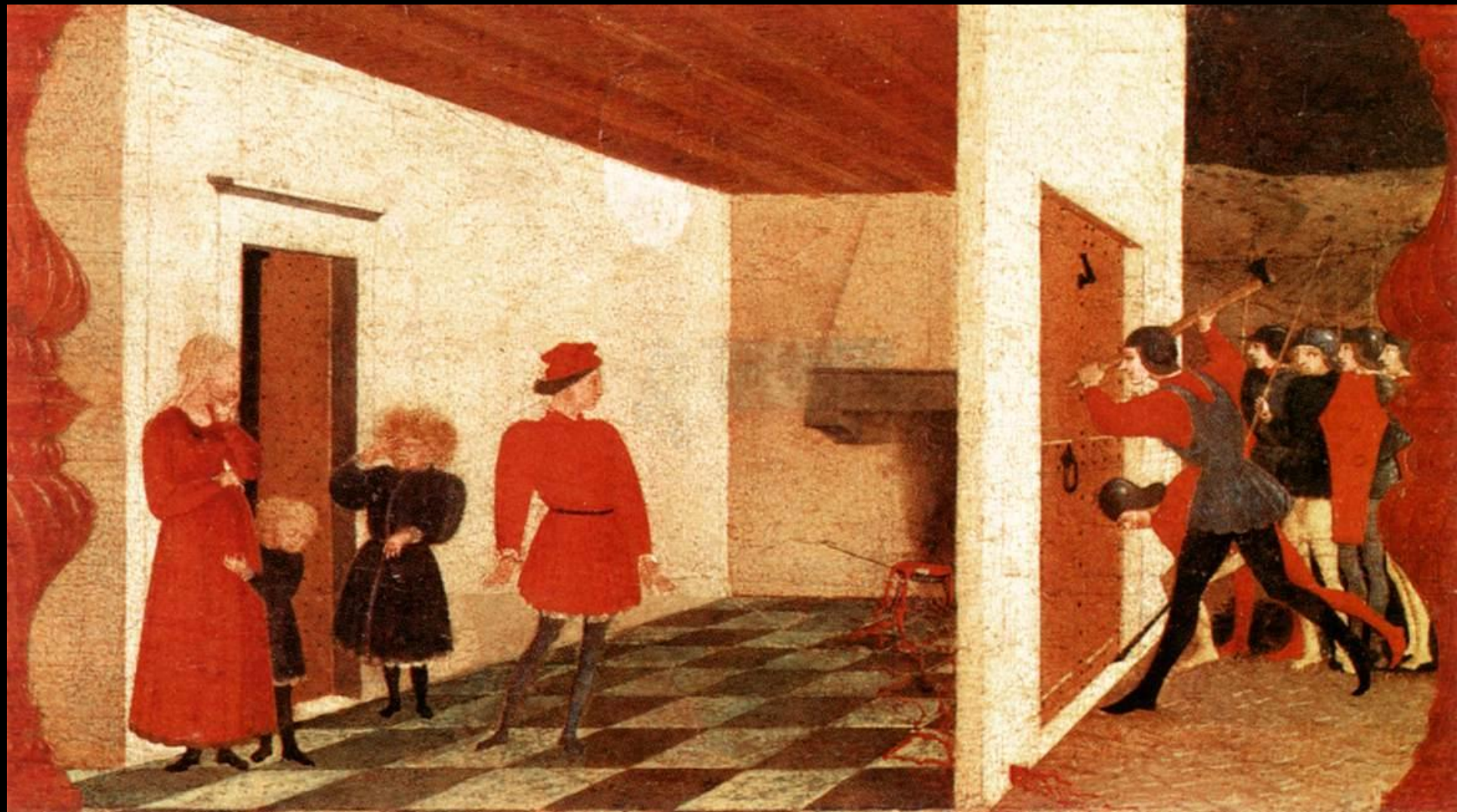

Paolo Uccello: "Miracle of the Profaned Host", n.1467-1469





Paolo Uccello: "Saint George and the Dragon", n. 1470



Piero della Francesca: "Flagellation of Christ", n. 1455–1460

NEDERLANDSCHE EXLIBRIS-KRING 1 JAN. 1947



WIJ KOMEN ER UIT!

M. C. Escher: "Well", 1947

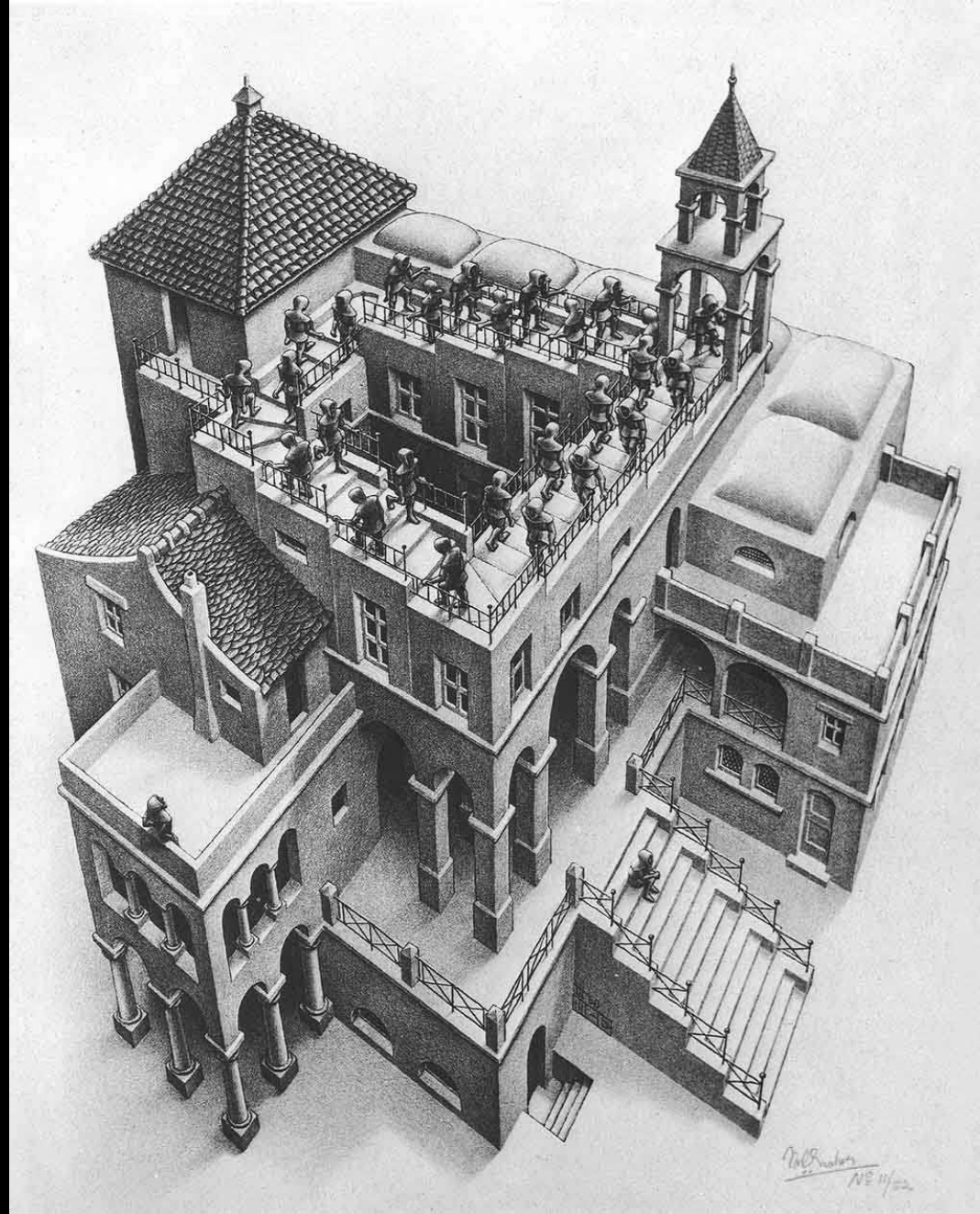

M. C. Escher: "Ascending and Descending", 1960



M. C. Escher: "Self-Portrait in Spherical Mirror", 1935

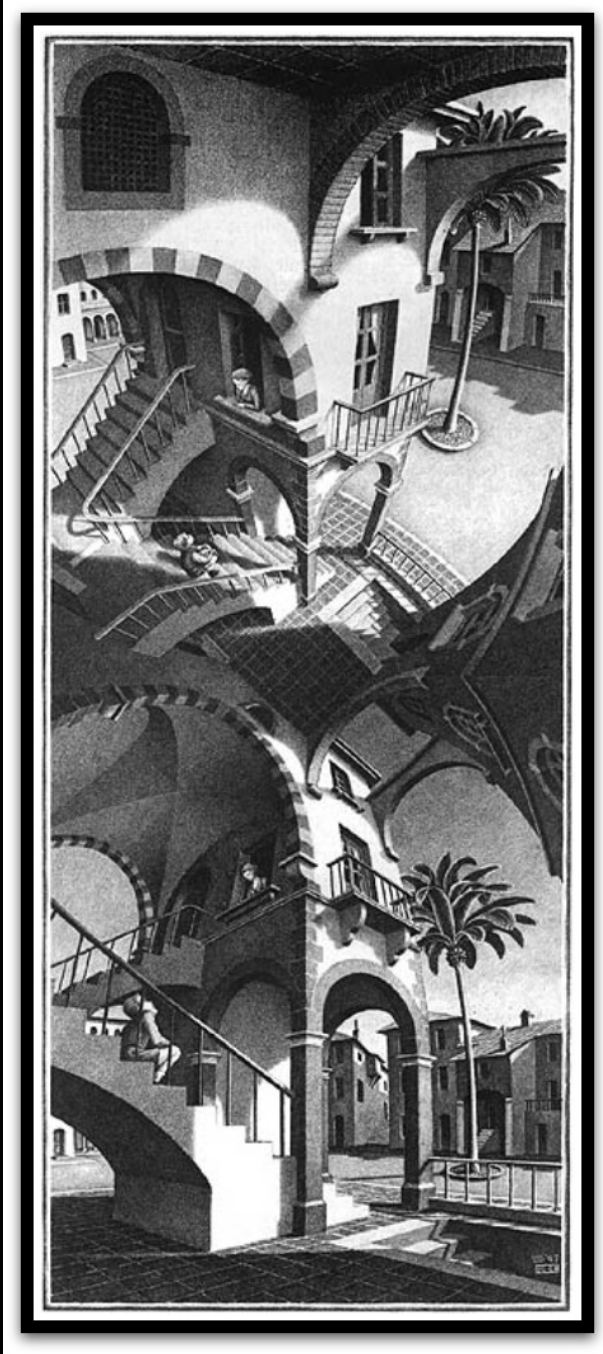

M. C. Escher: "Up and down", 1947

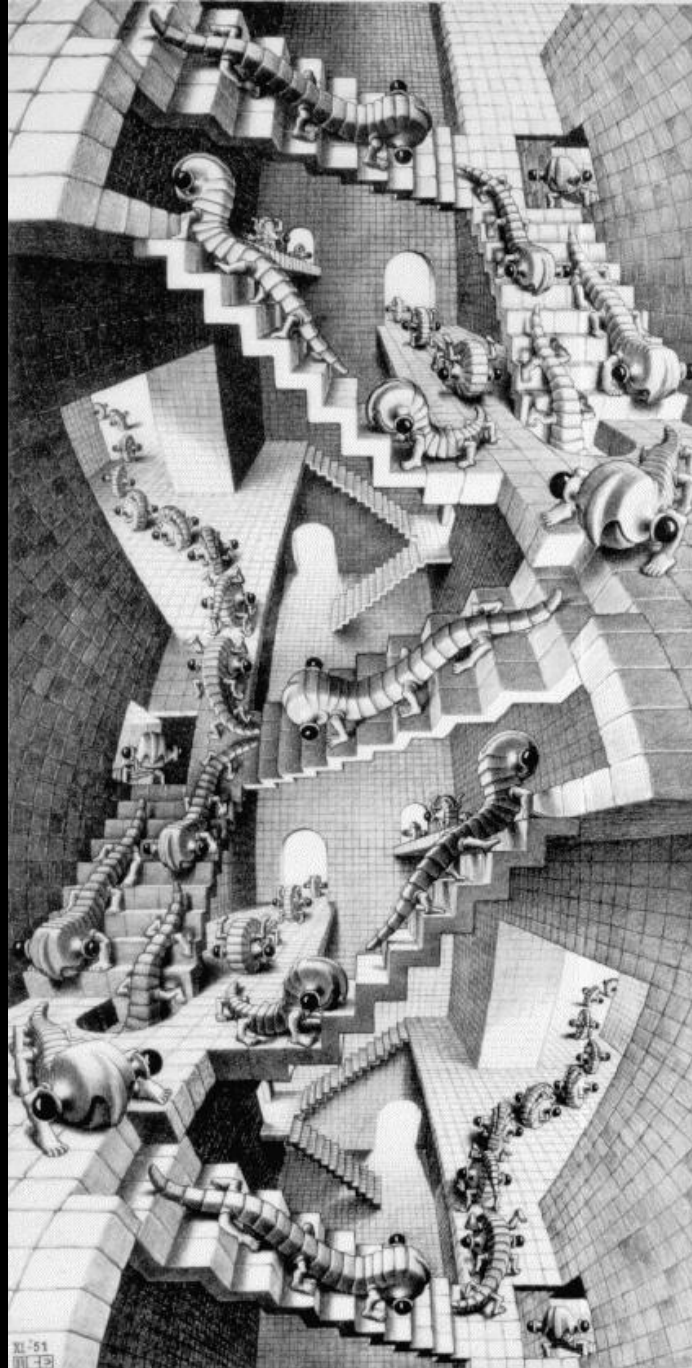

M. C. Escher: "House of Stairs", 1951

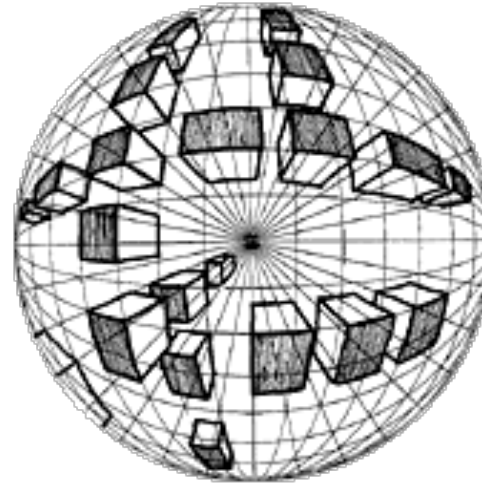
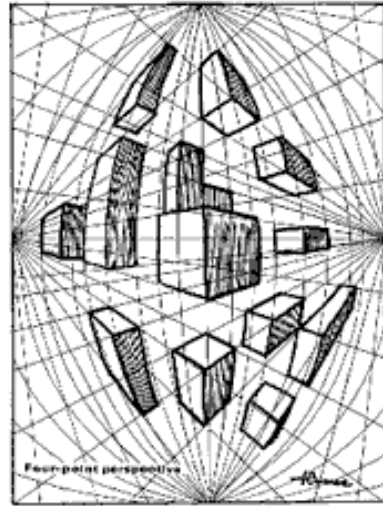
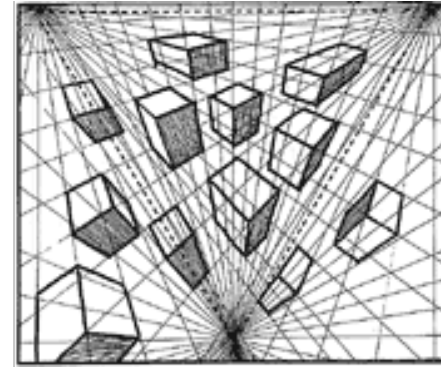
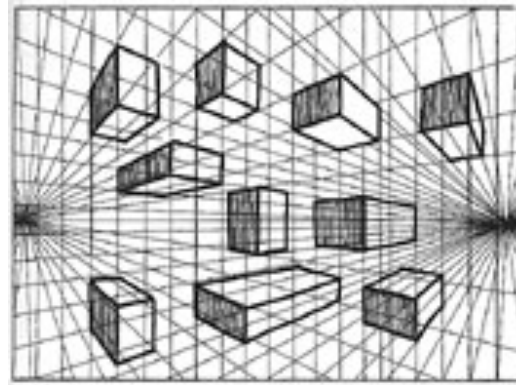
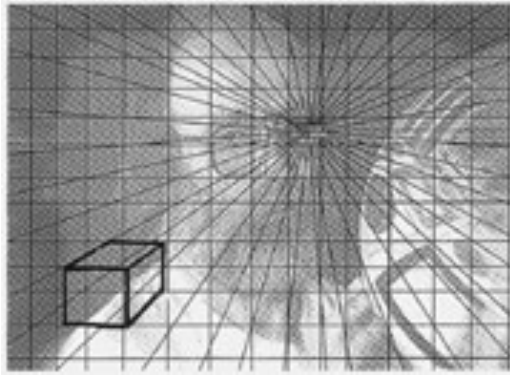

Dick Termes: 6-point perspective



Dick Termes: "Reflecting Back"

<http://www.youtube.com/watch?v=Uw-IB9GpmY4>

Ames room: [https://www.youtube.com/watch?v=Jg\\_nIPpd7Yw](https://www.youtube.com/watch?v=Jg_nIPpd7Yw)

Kokichi Sugihara: <https://www.youtube.com/watch?v=1dISzq4kIPc>

# Projections



Hans Holbein the Younger: "Ambassadors", 1533

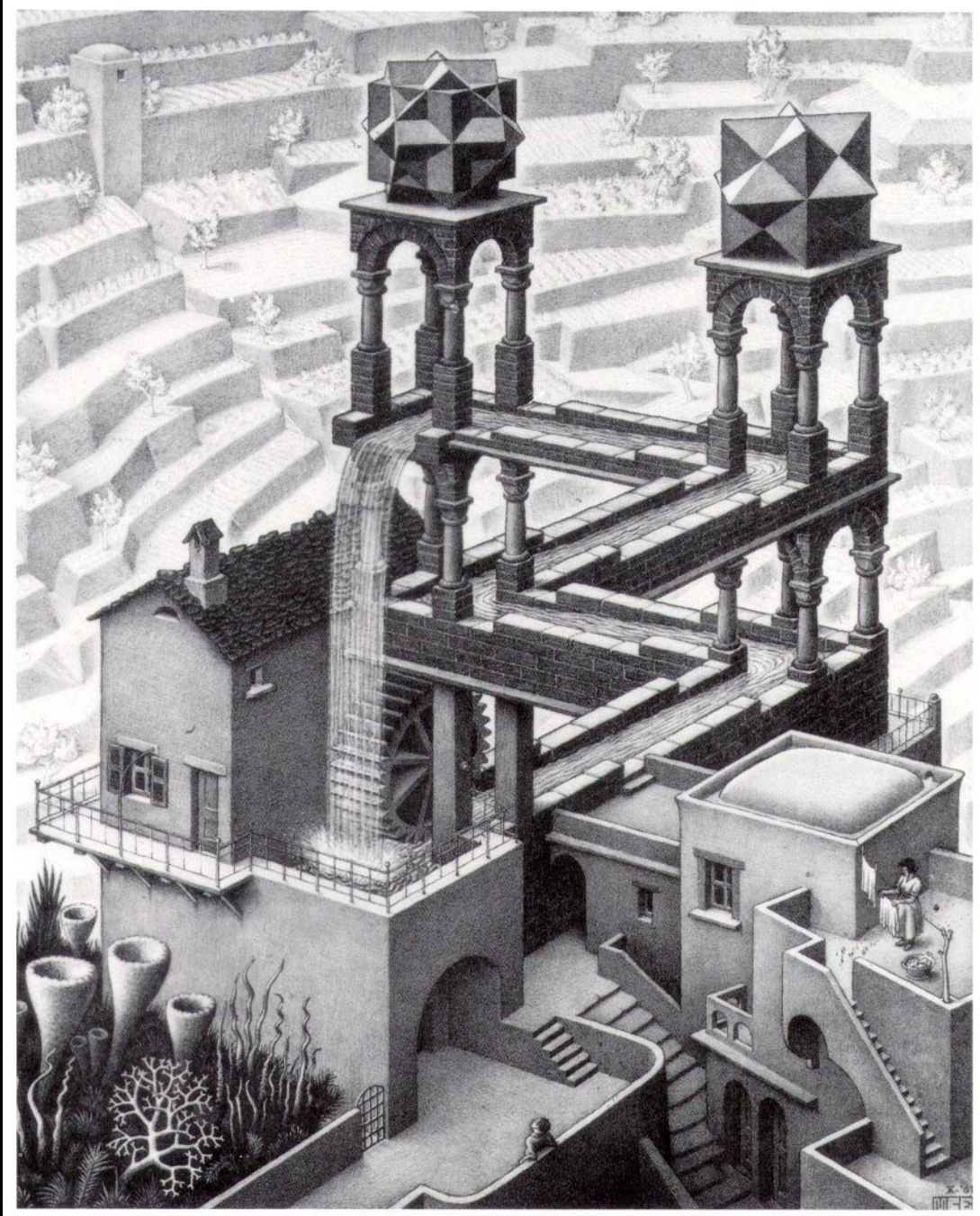

M. C. Escher: "Waterfall", 1961

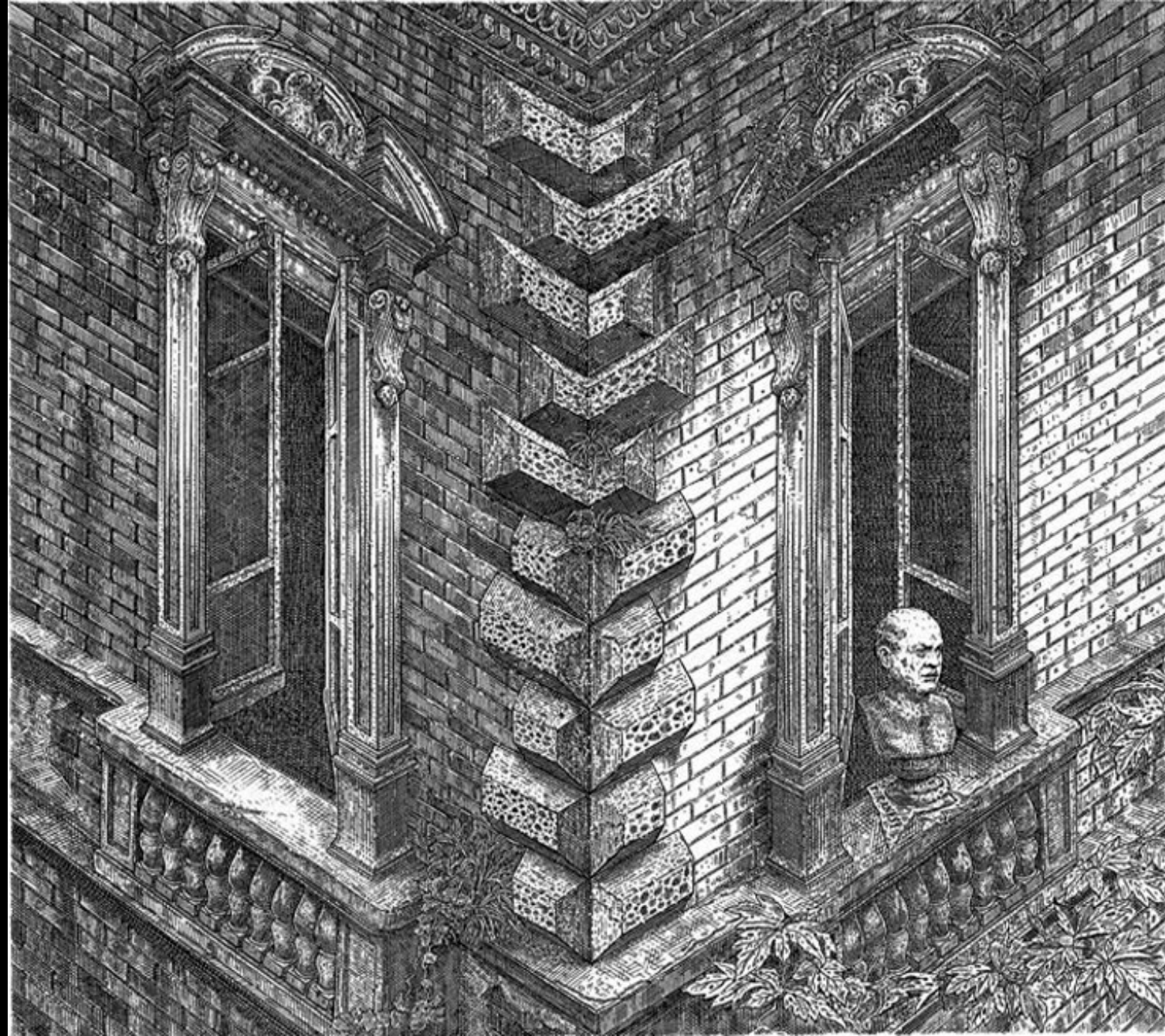

István Orosz: "Piranesi in Budapest"

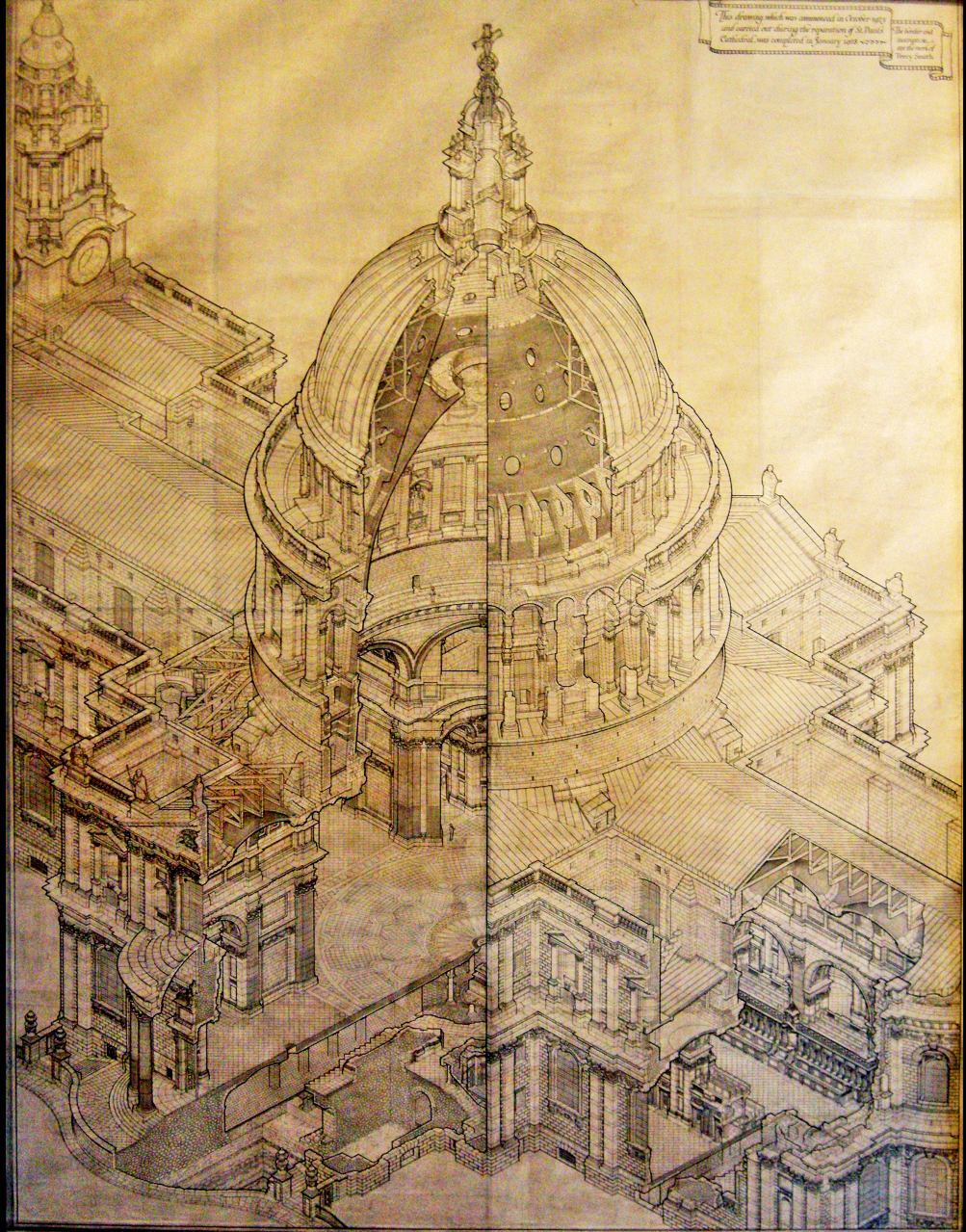

This drawing which was commenced in October 1791 and carried out during the repairs of St Paul's Cathedral, was completed in January 1792

TO WILLIAM DUNN, F.R.S.B.A.  
who first suggested the idea of shewing the construction of St Paul's Cathedral by Isometric Projection—  
this drawing is inscribed by MERVYN EDMUND MACARTNEY, F.S.A. Surveyor to the Fabric—  
Measured and drawn by R.B. BROOK-GREAVES in collaboration with W. GODFREY ALLEN  
Valuable assistance has been rendered by Matthew Dawson F.R.S.B.A. & E.J. Bolwell



István Orosz: "Raven"





István Orosz: "Verne"





Edgar Mueller: "The Crevasse", 2008



Edgar Mueller: "Duality", 2010



# Ruled surfaces



Antoine Pevsner: "Developable Surface", 1941

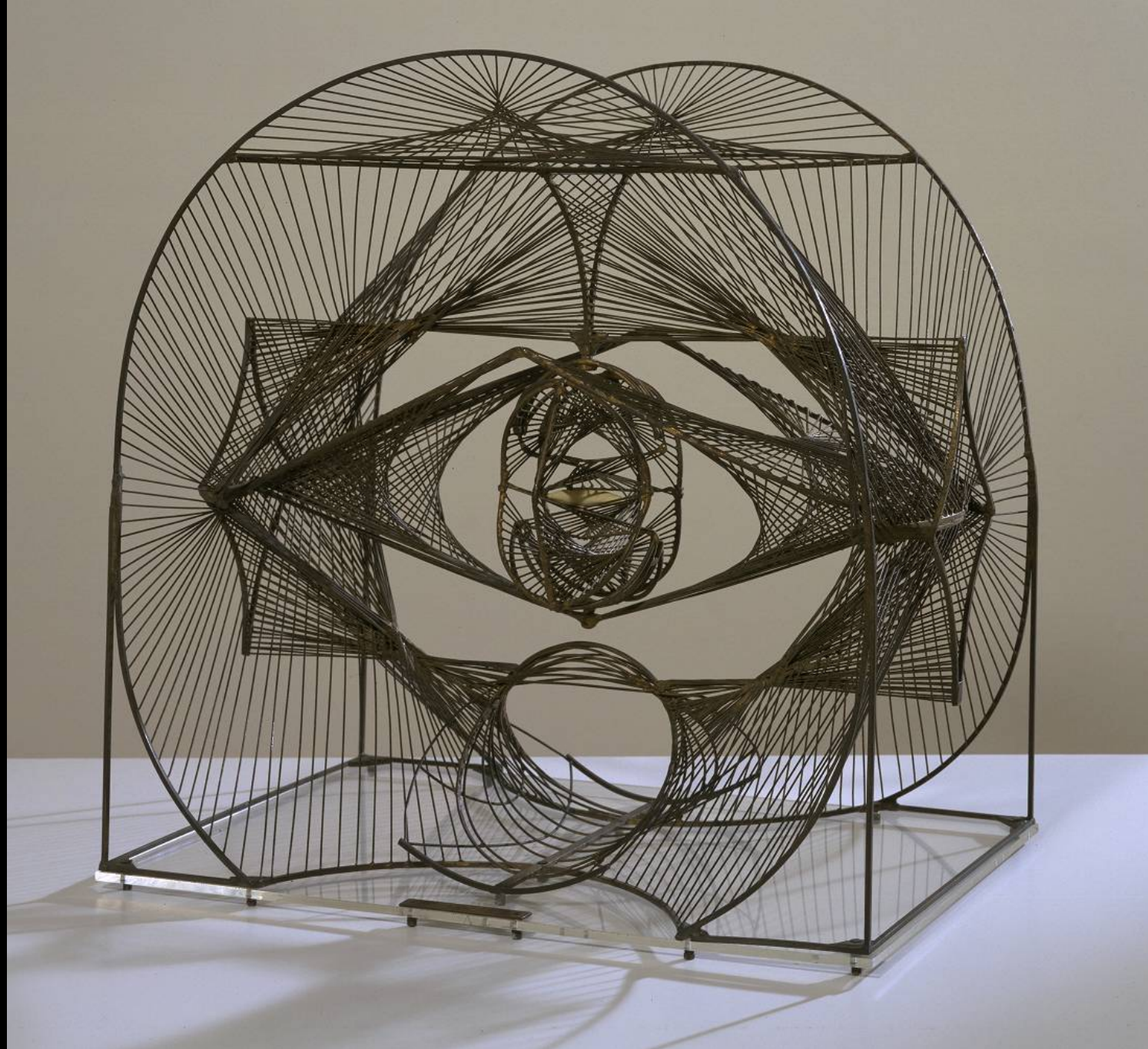

Antoine Pevsner: "Maquette of a Monument Symbolising the Liberation of the Spirit", 1952



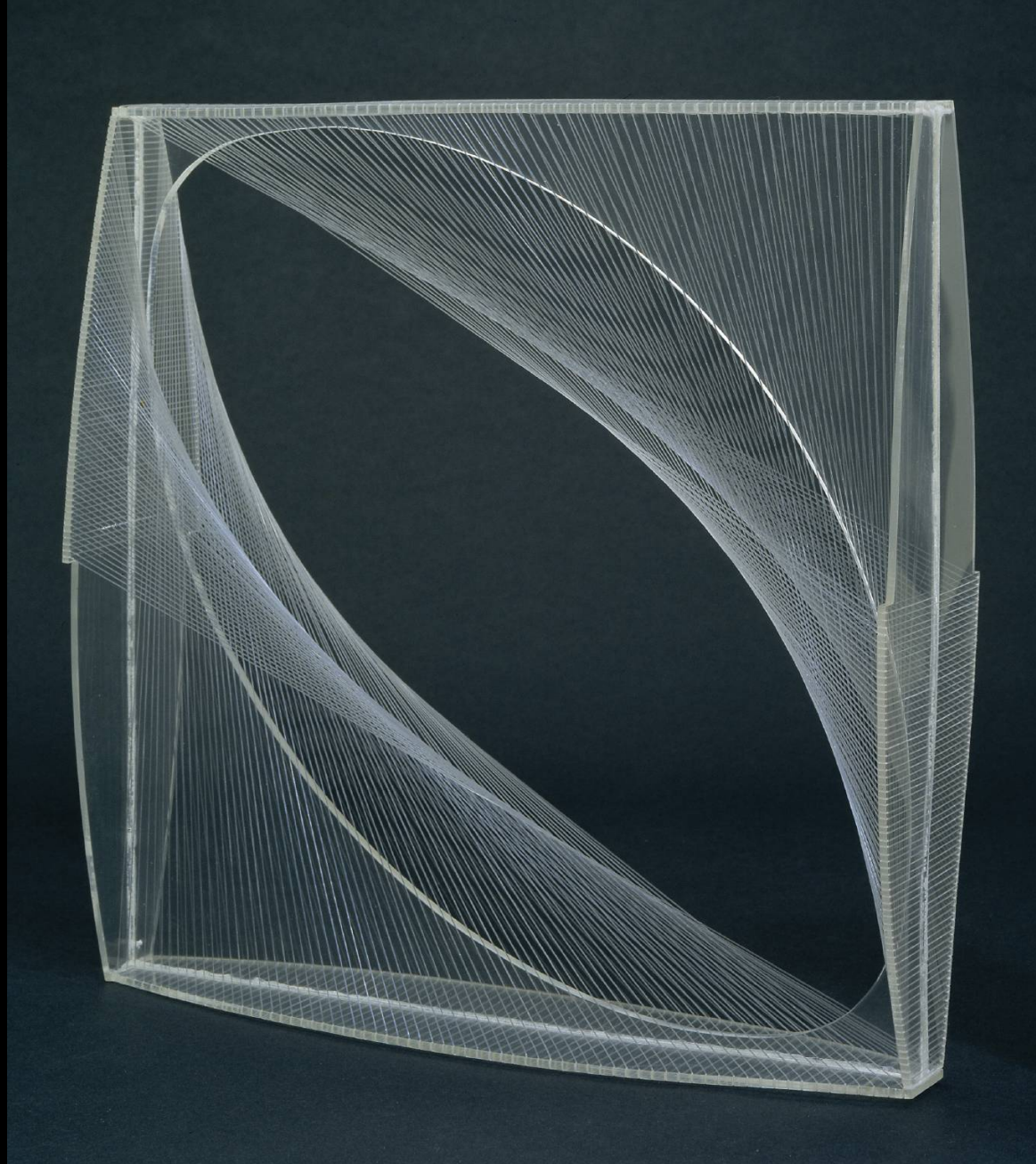

Naum Gabo: "Linear Construction no.1", 1943



Naum Gabo: "Linear Construction No.2", 1950



Henry Moore: "Stringed Mother and Child"



Henry Moore: "Stringed Figure", 1938-60



Henry Moore: "Bird Basket", 1939

# Minimal surfaces

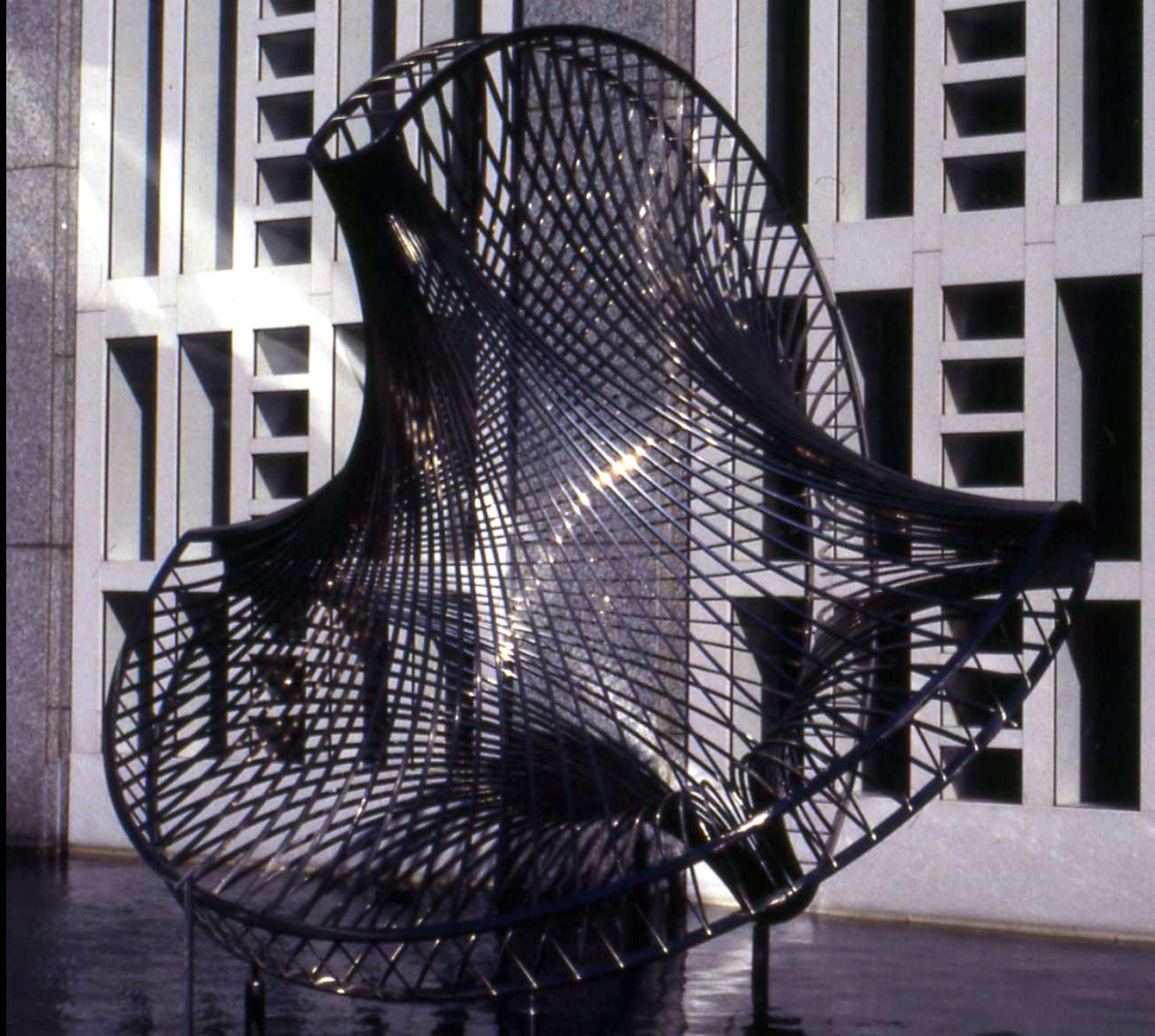

Charles O. Perry: "Early Mace", 1971



Harriet E. Brisson: "Schwarz Surface", 1986





Carlo H. Séquin & Brent Collins: "Whirled White Web", 2002



Carlo H. Séquin: "Dodecahedral Volution", 2009



Eva Hild: "Funnel Loop"

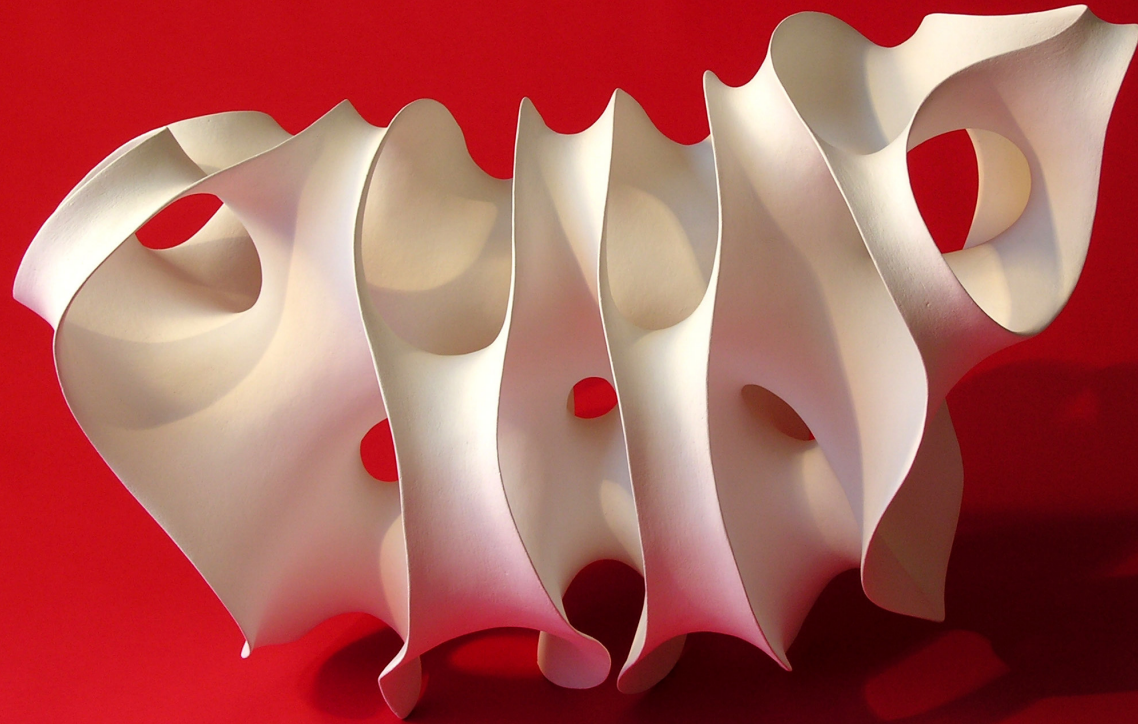

Eva Hild: "Struktur"



Eva Hild: "Loop Trough"

Knots



George K. Francis:

<https://www.youtube.com/watch?v=x4-0oM5BU6I>



Carlo H. Séquin: "Tetratangle", 1983





Keizo Ushio, 2008



Keizo Ushio: "Circle", 2010



Bathsheba Grossman: "Quintrino" & "Antipot"



Bjarne Jespersen: "Royal Family" 2002



Rinus Roelofs : "Cilindrical Knot"



Rinus Roelofs : "Connected Holes"

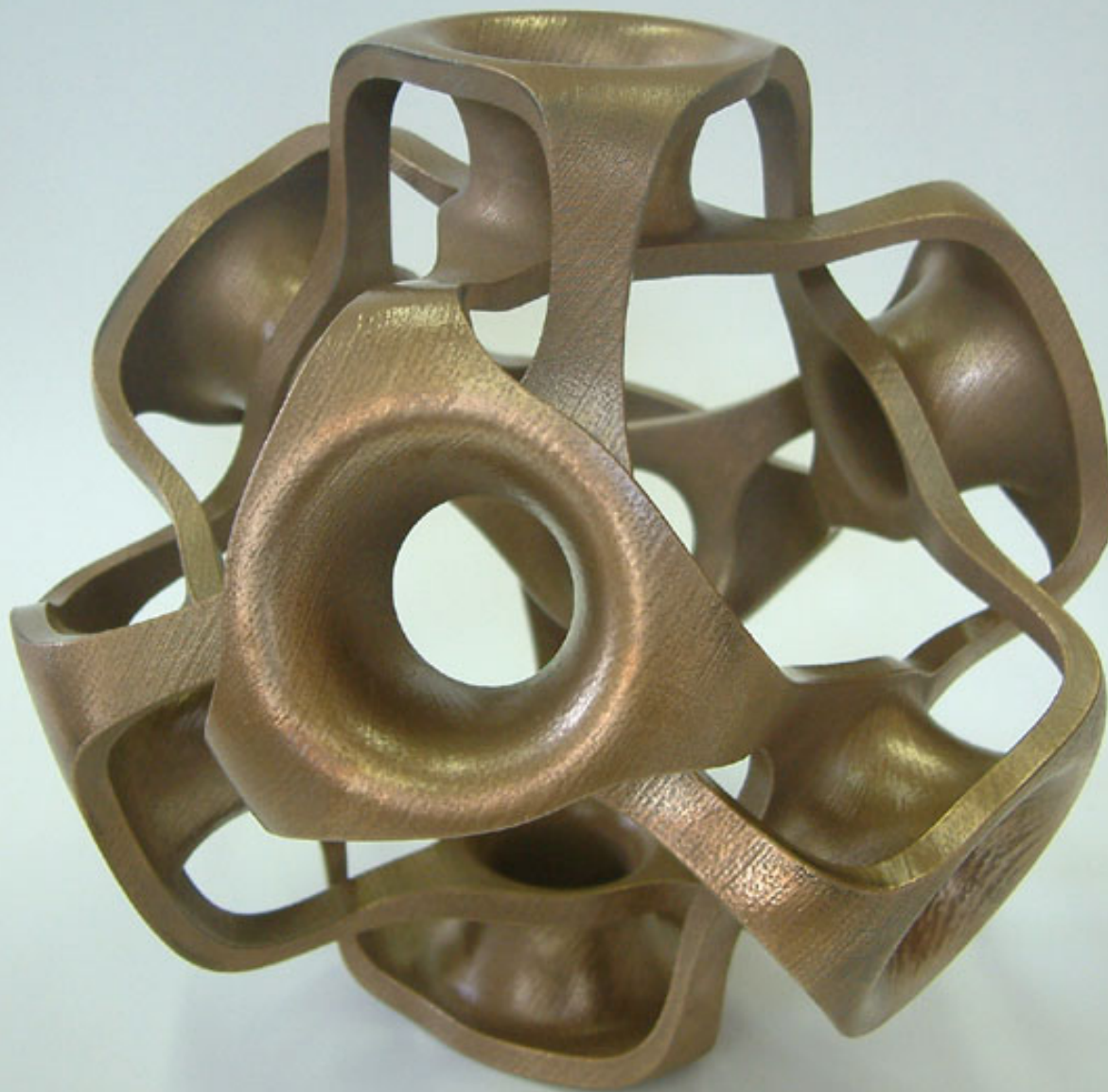

Rinus Roelofs : "Octahedral Construction"

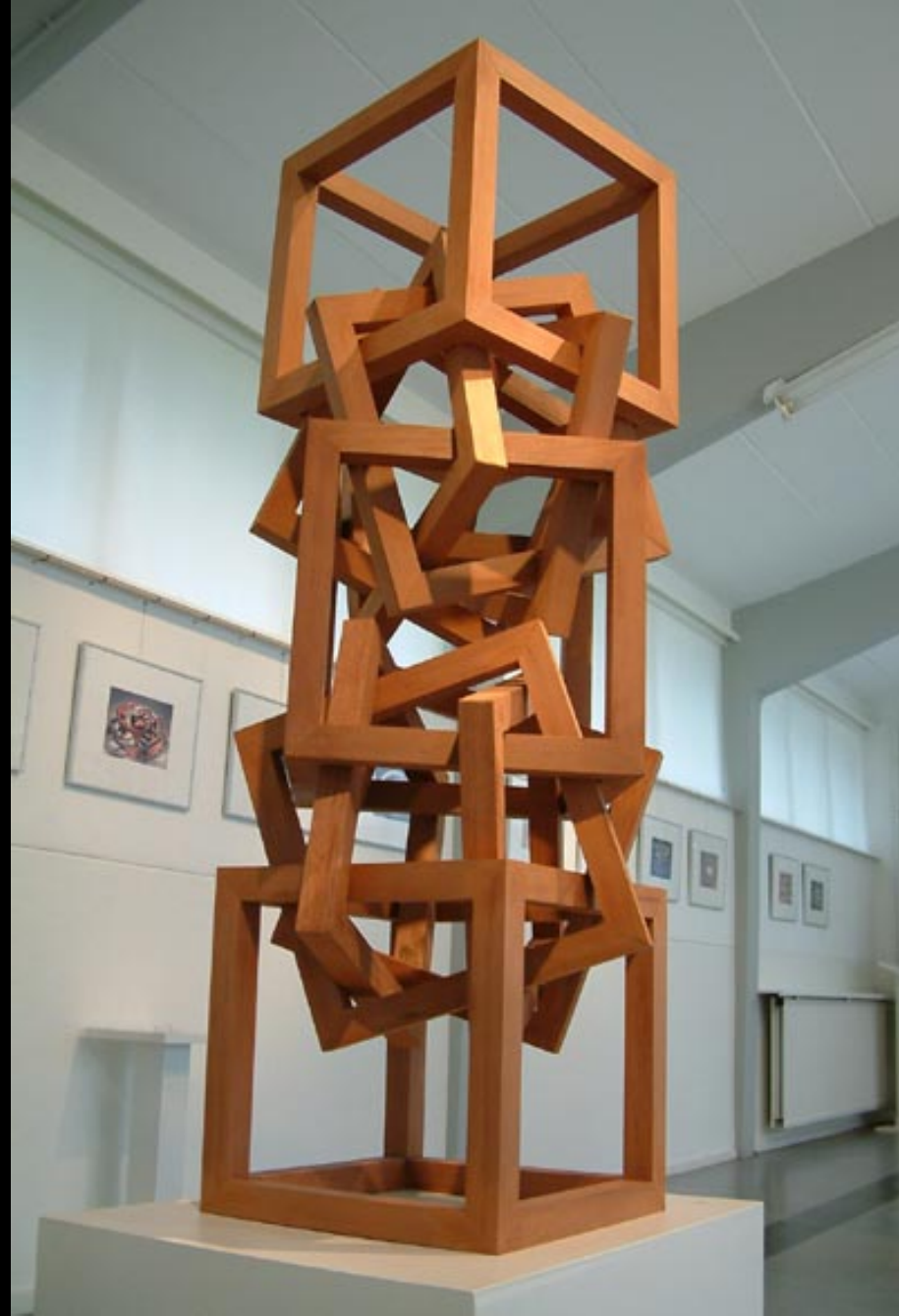

Rinus Roelofs: "Linked Cubes"



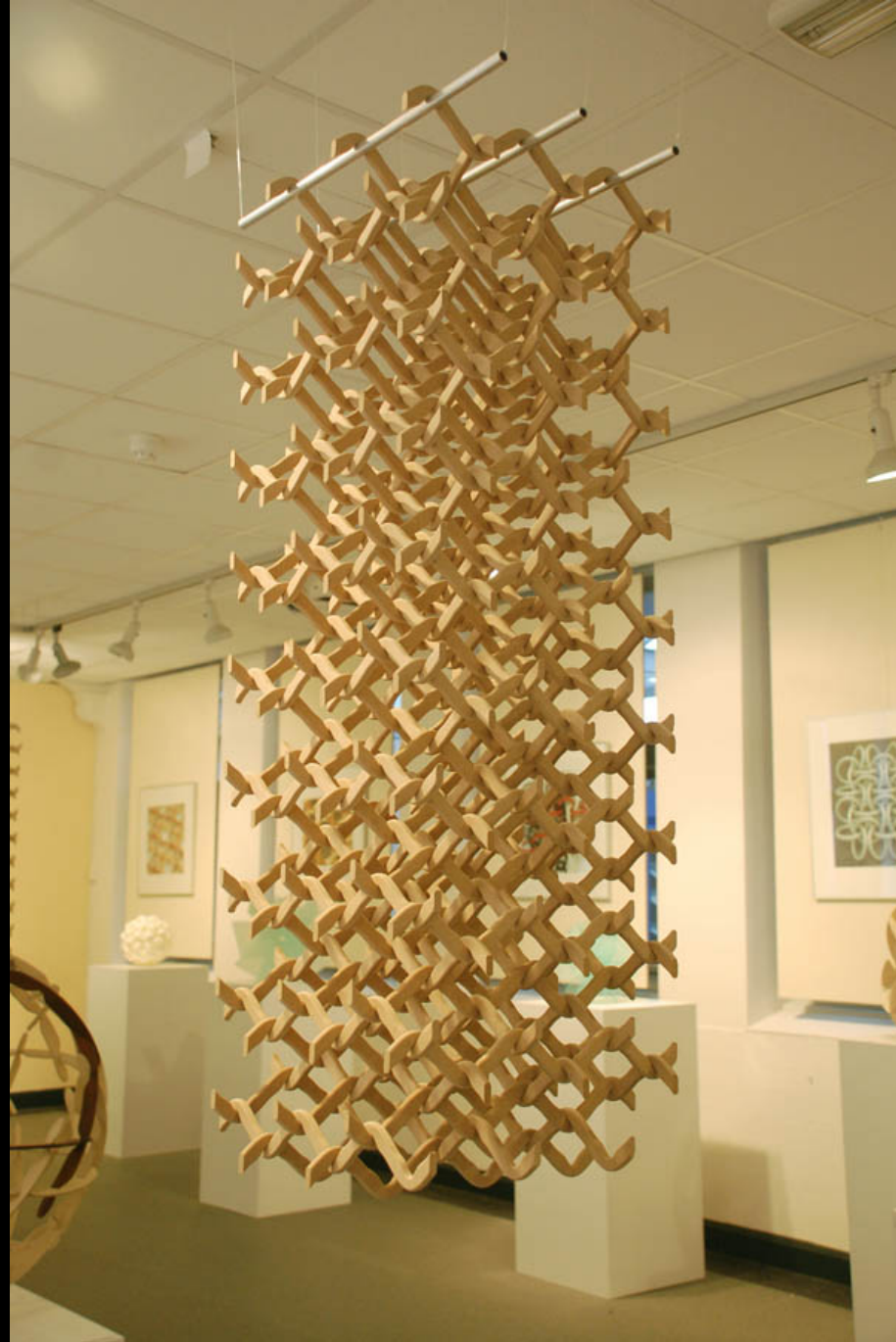

Rinus Roelofs: "3D weaving"



Vladimir Bulatov: "Dodecahedron XIV" & "Icosahedron I"



Conrad Shawcross: "Chord", 2009

Mathematical objects



Sylvie Pic



Sylvie Pic

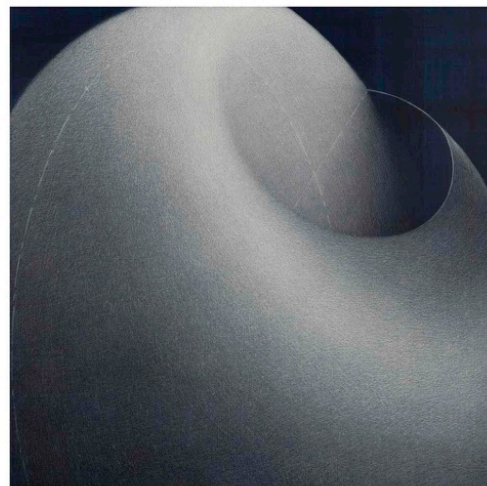
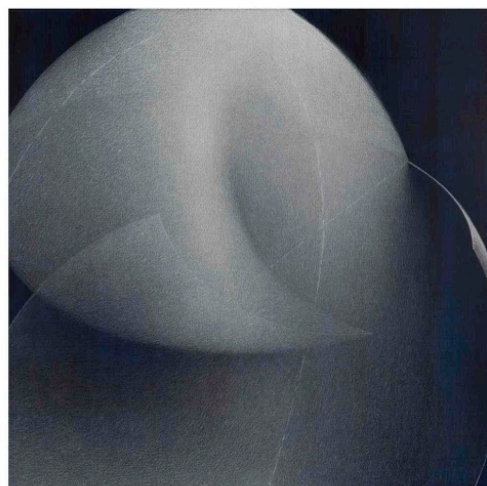
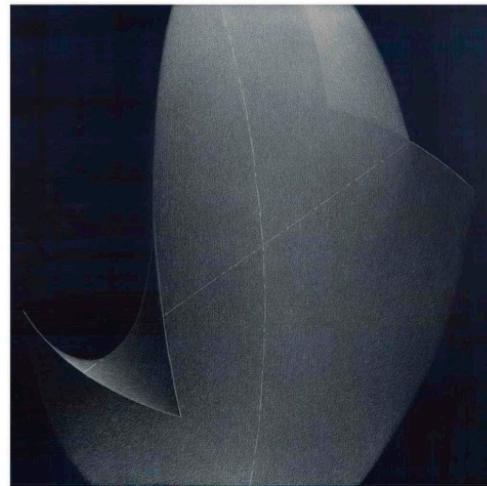
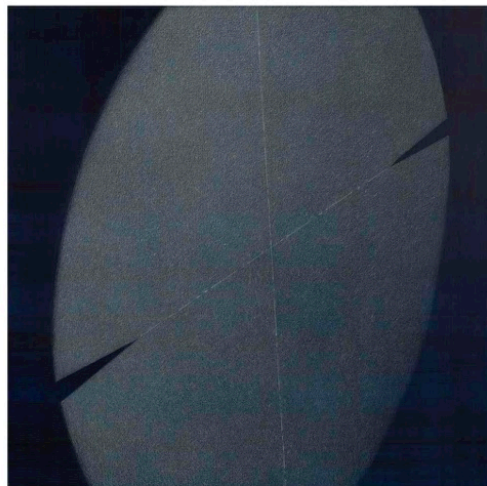

Sylvie Pic

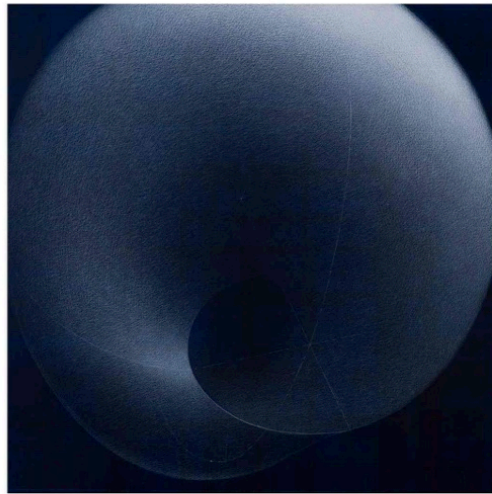
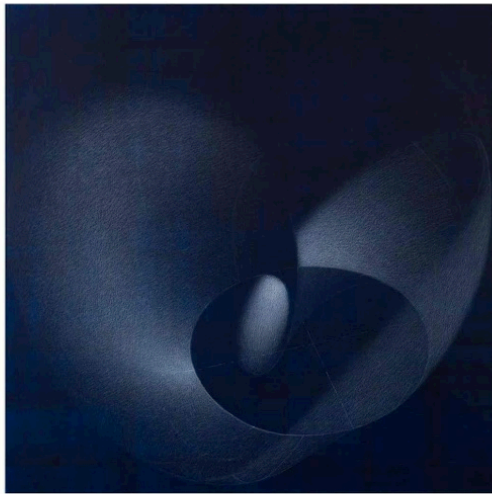
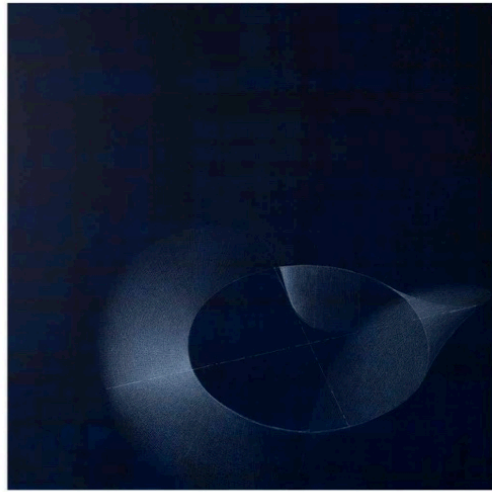
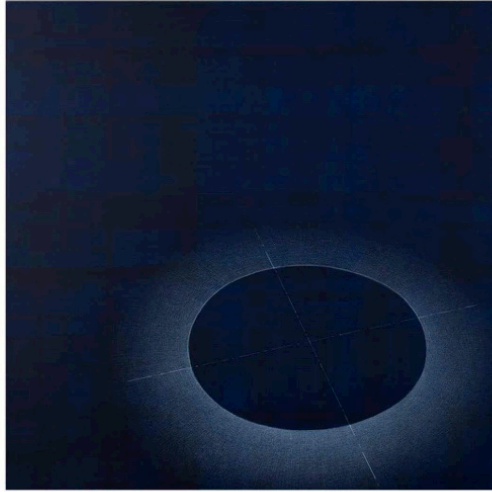

Sylvie Pic



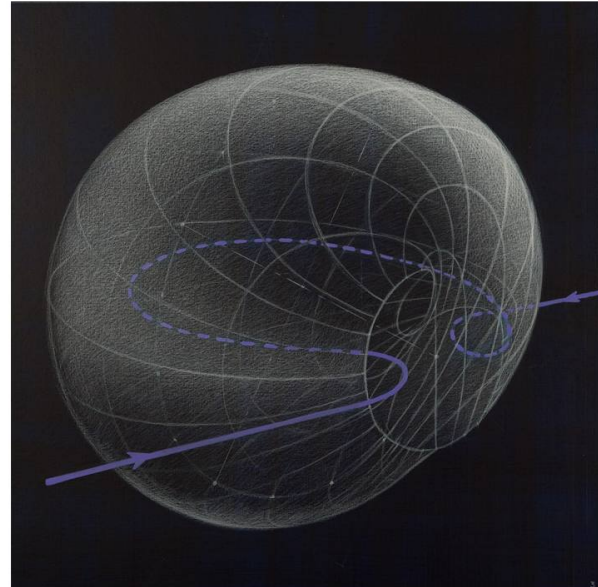
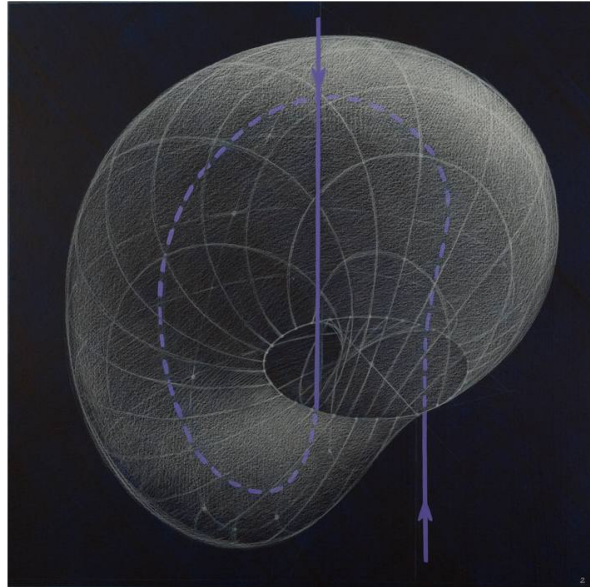
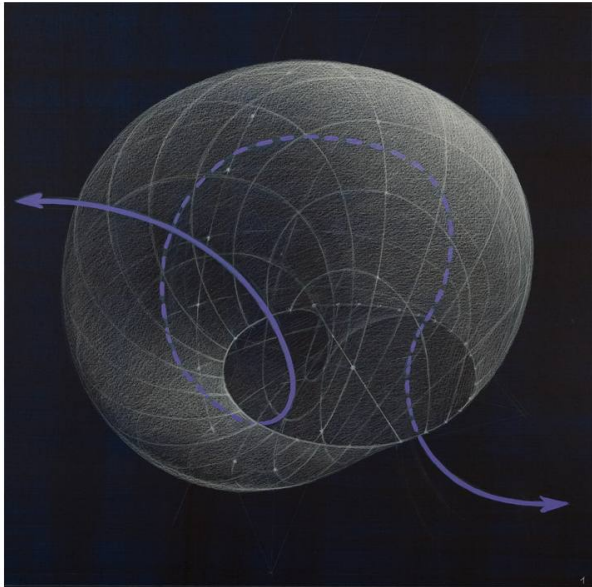

Sylvie Pic

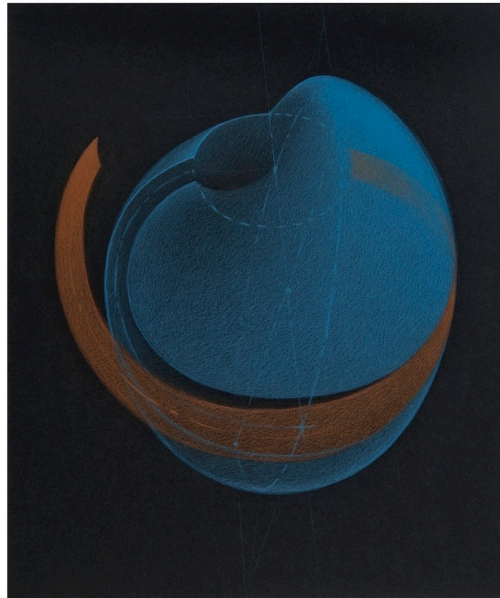
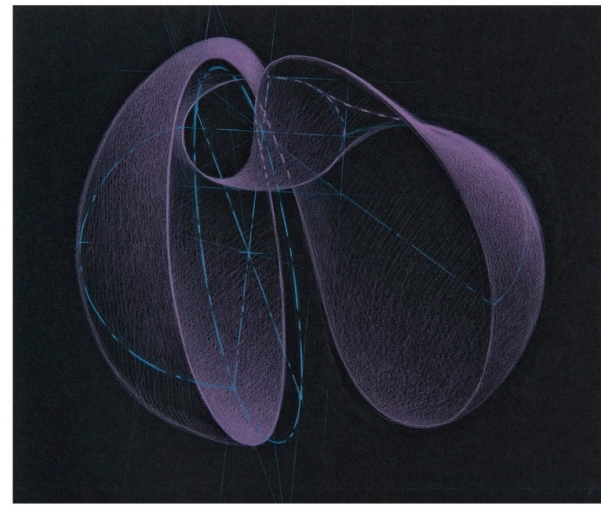
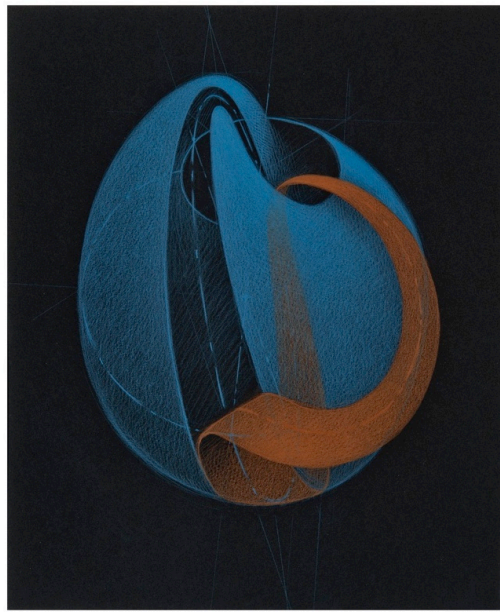

Sylvie Pic

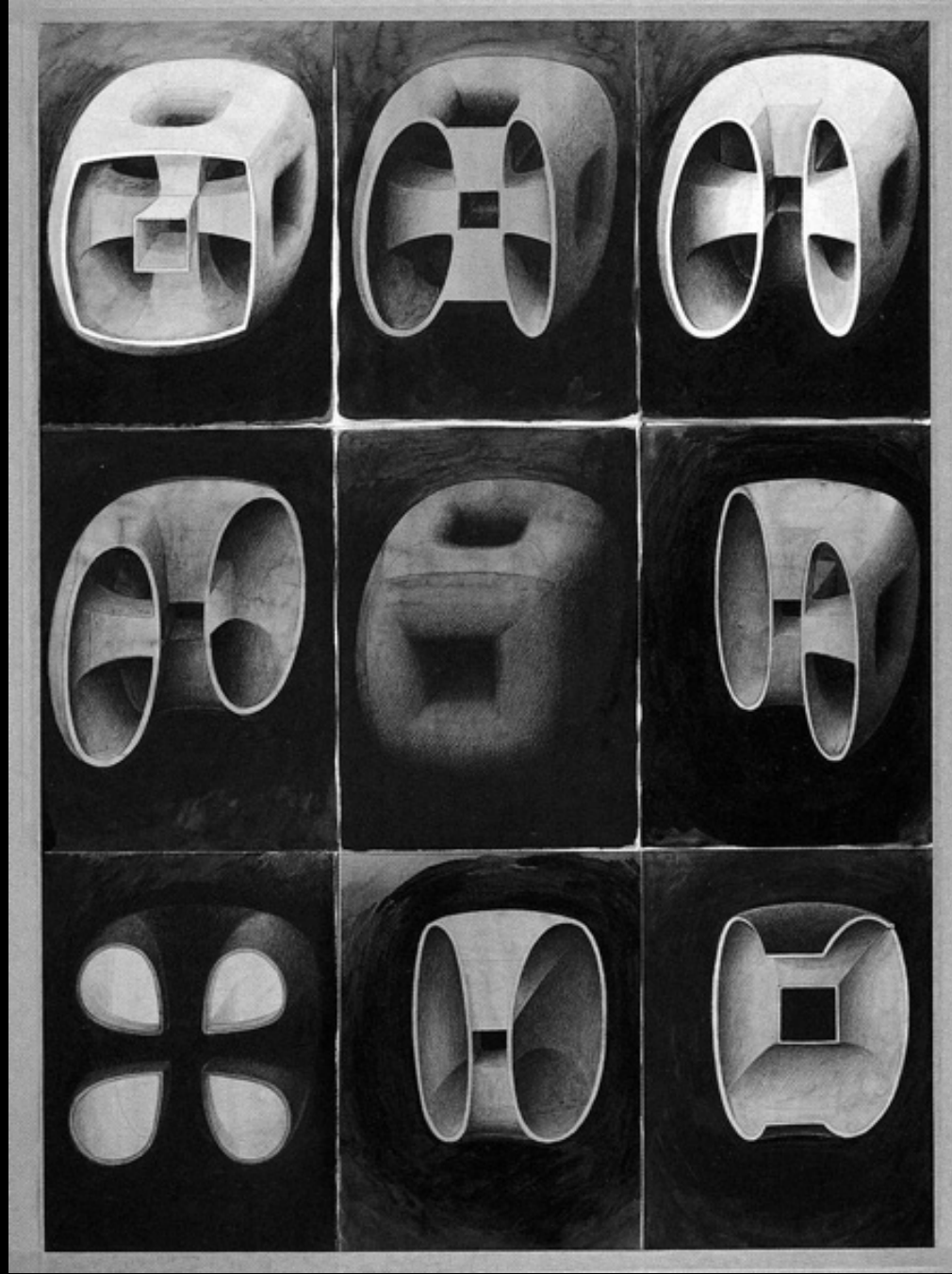

Sylvie Pic: "Toricube", 1998



Sylvie Pic

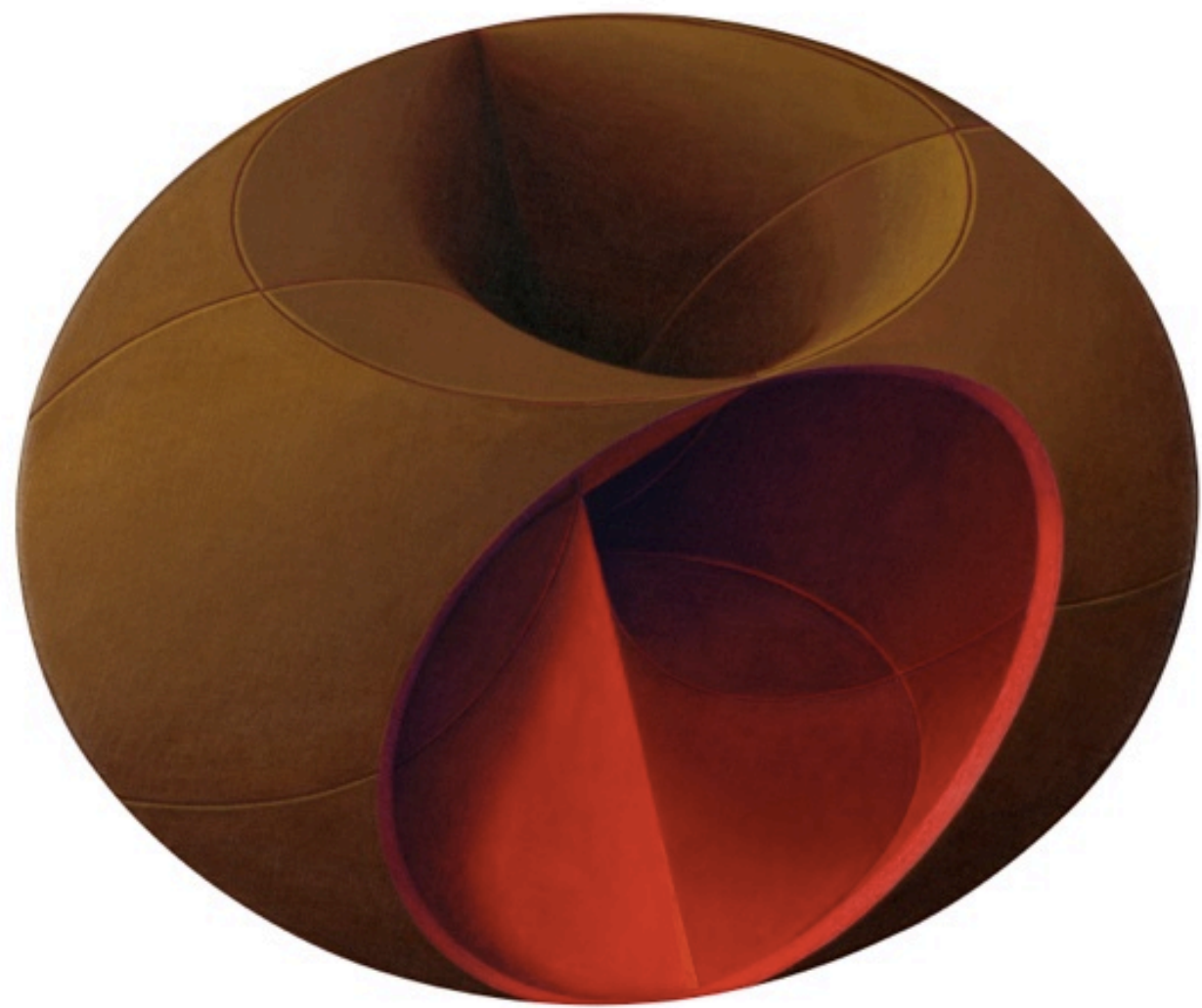

Sylvie Pic

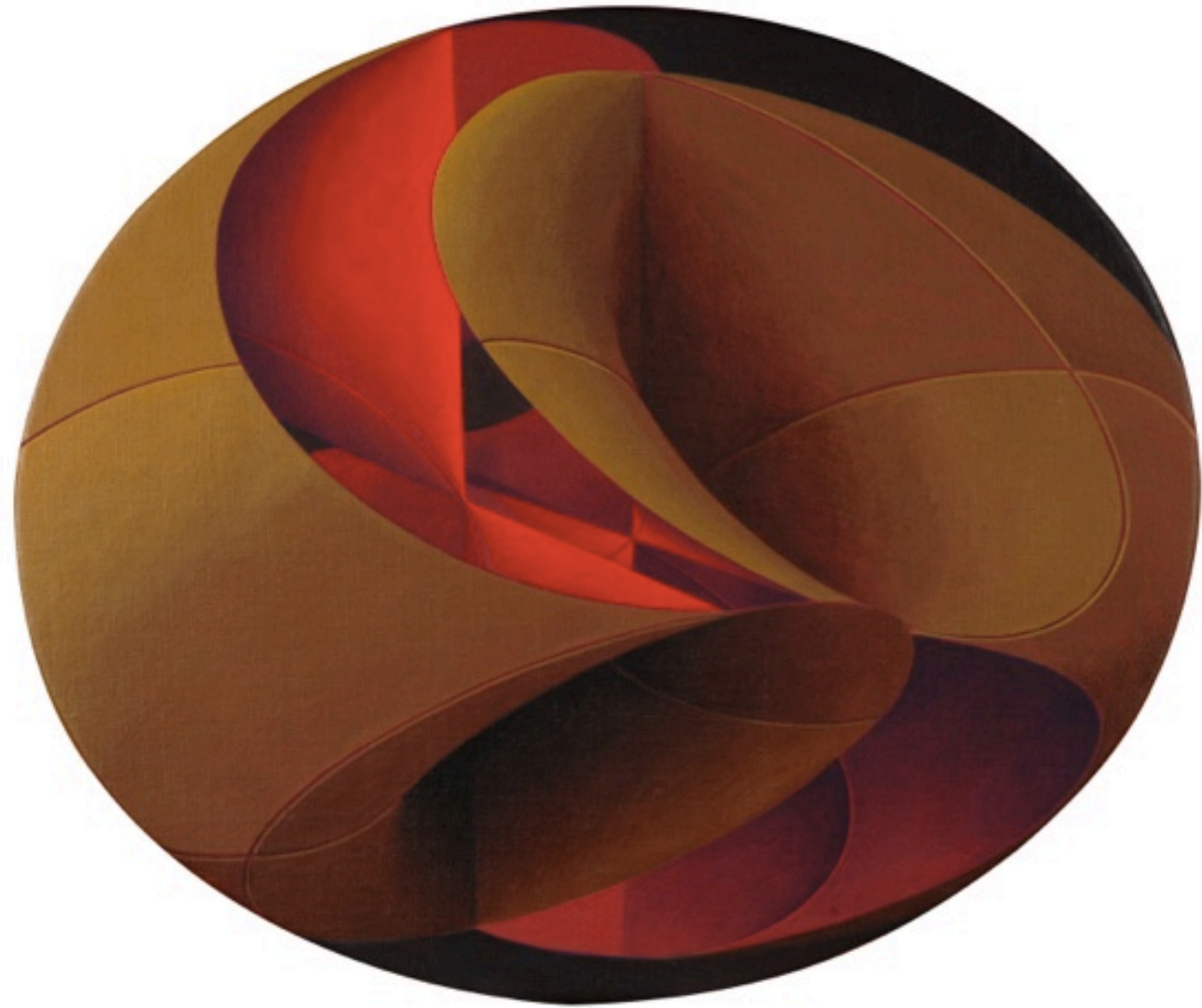

Sylvie Pic

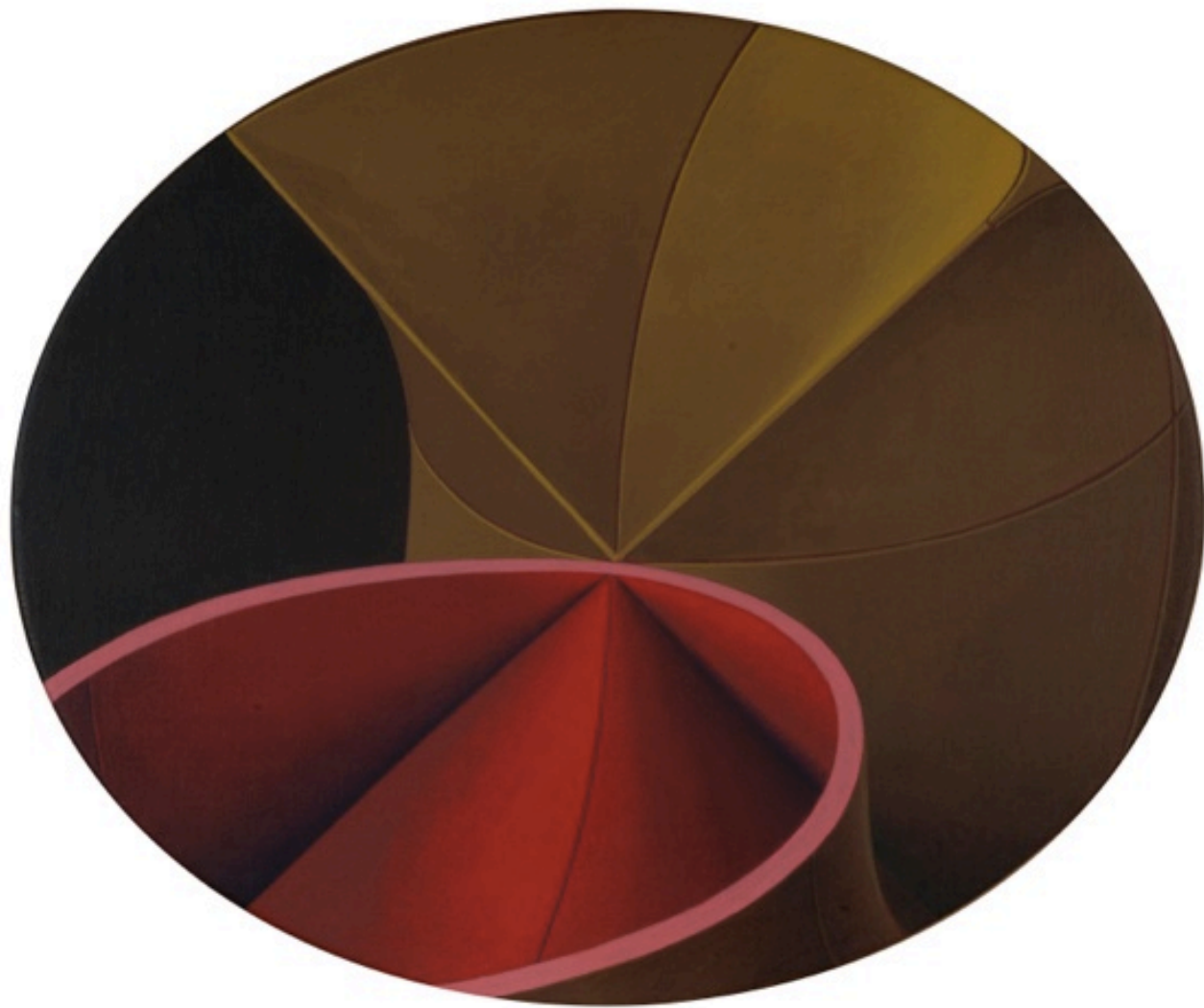

Sylvie Pic

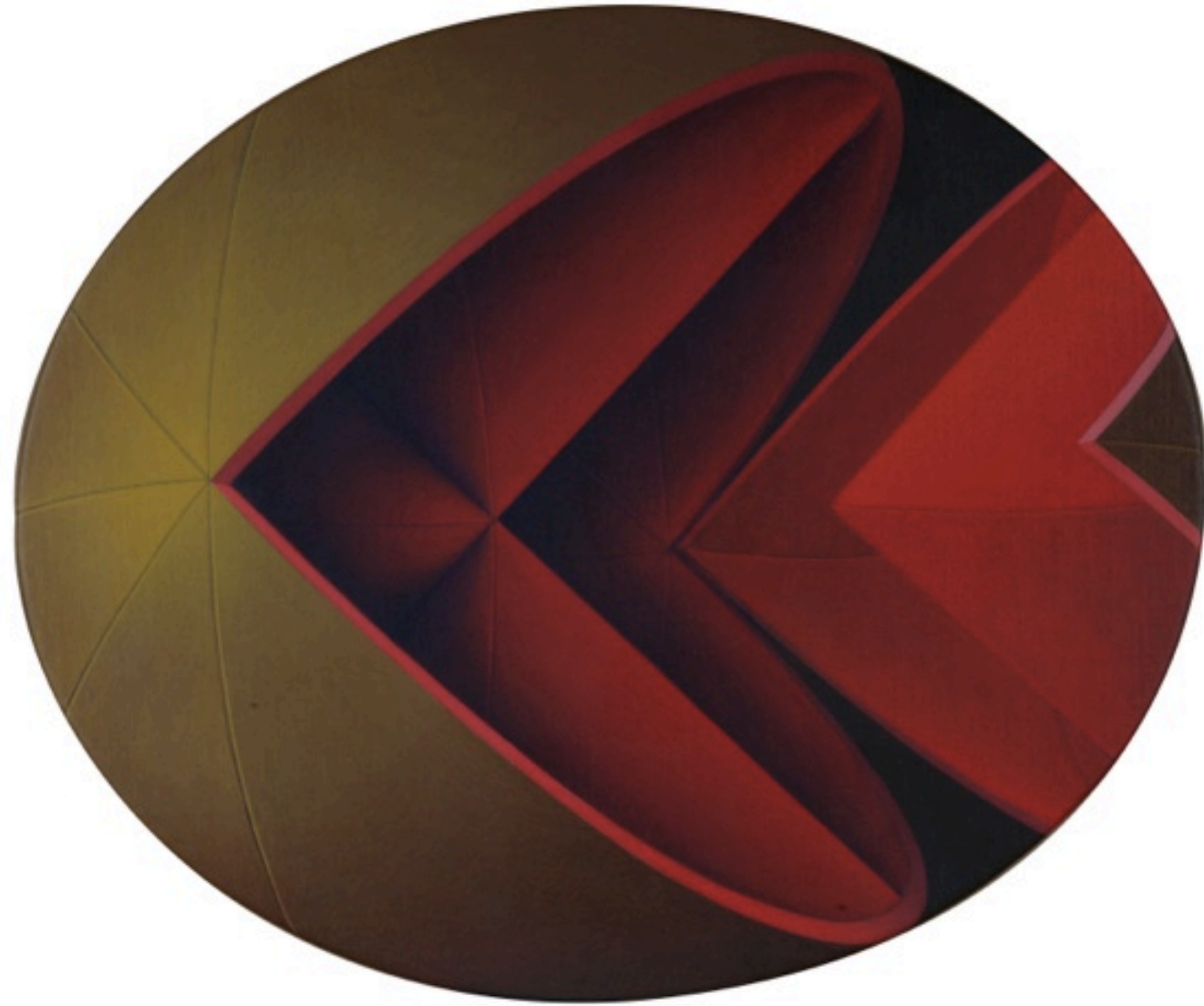

Sylvie Pic



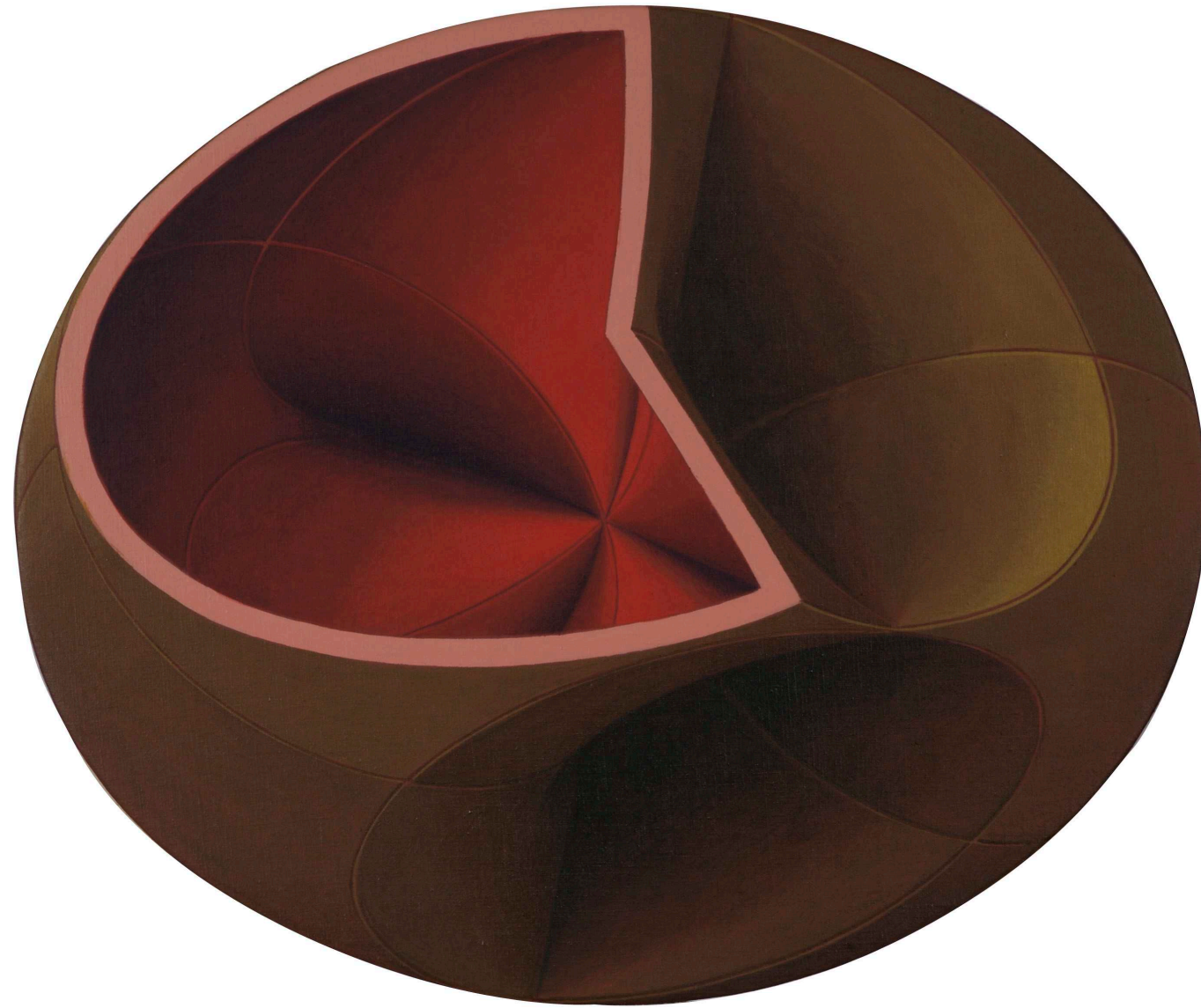

Sylvie Pic

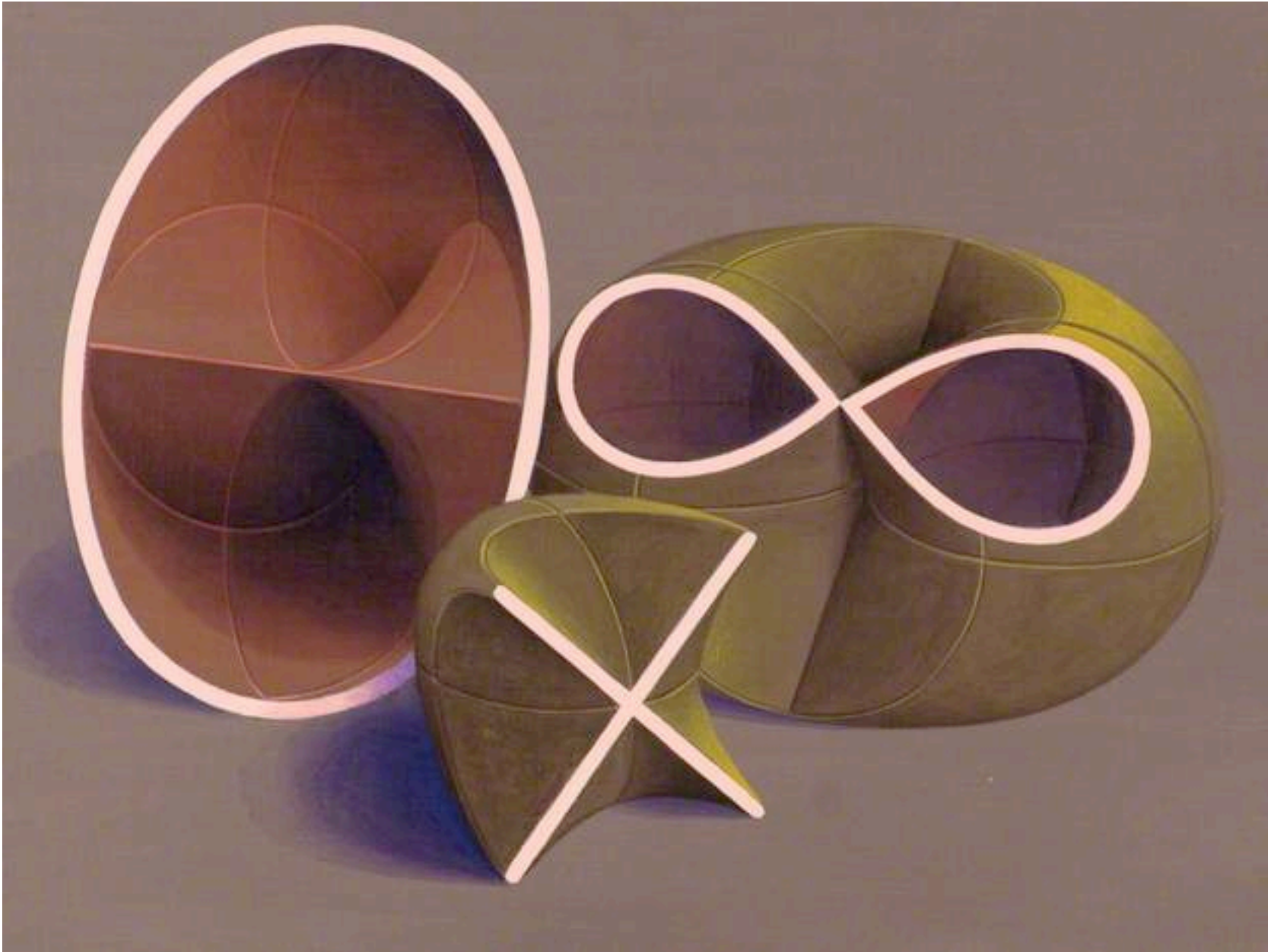

Sylvie Pic

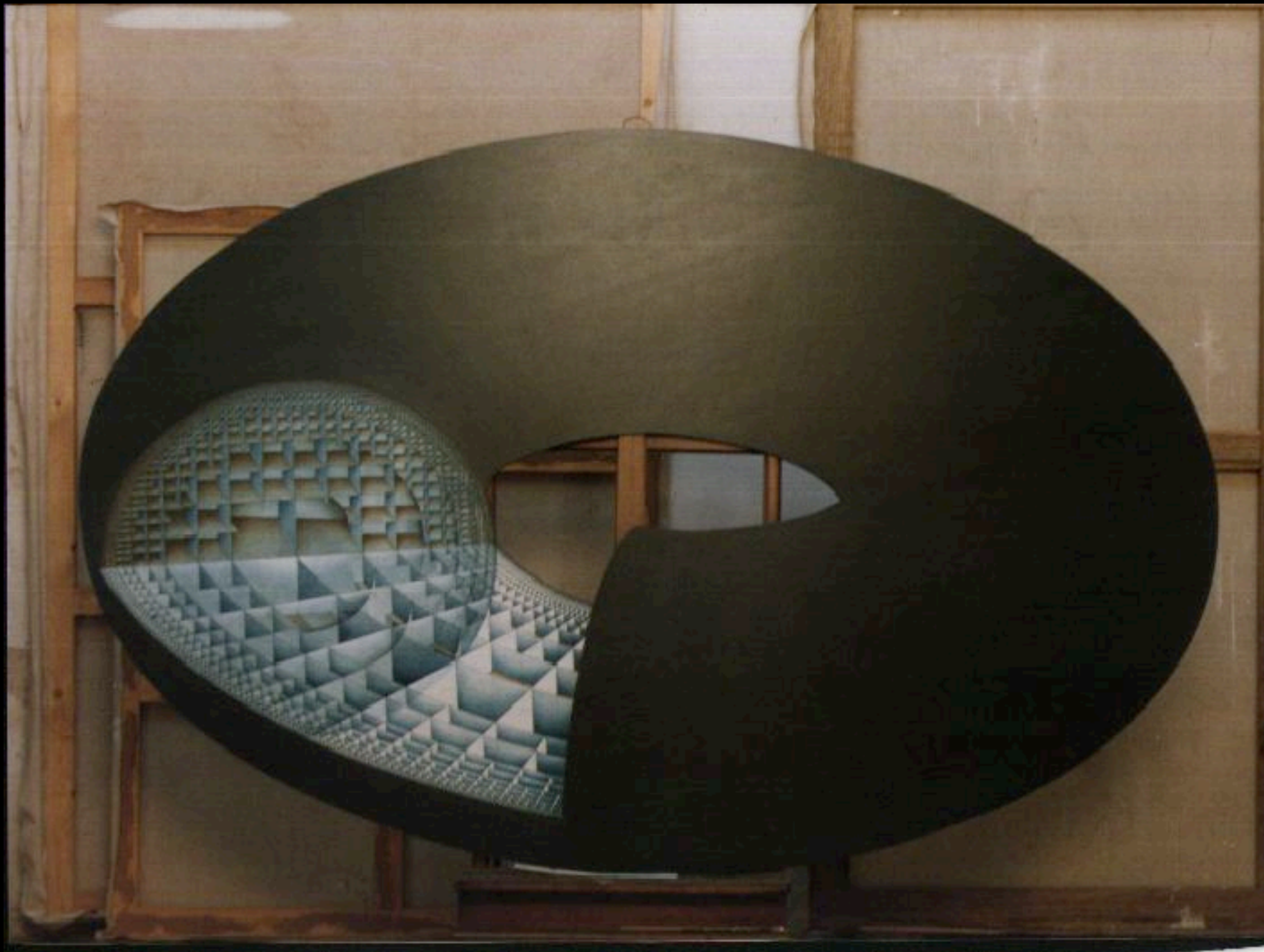

Sylvie Pic

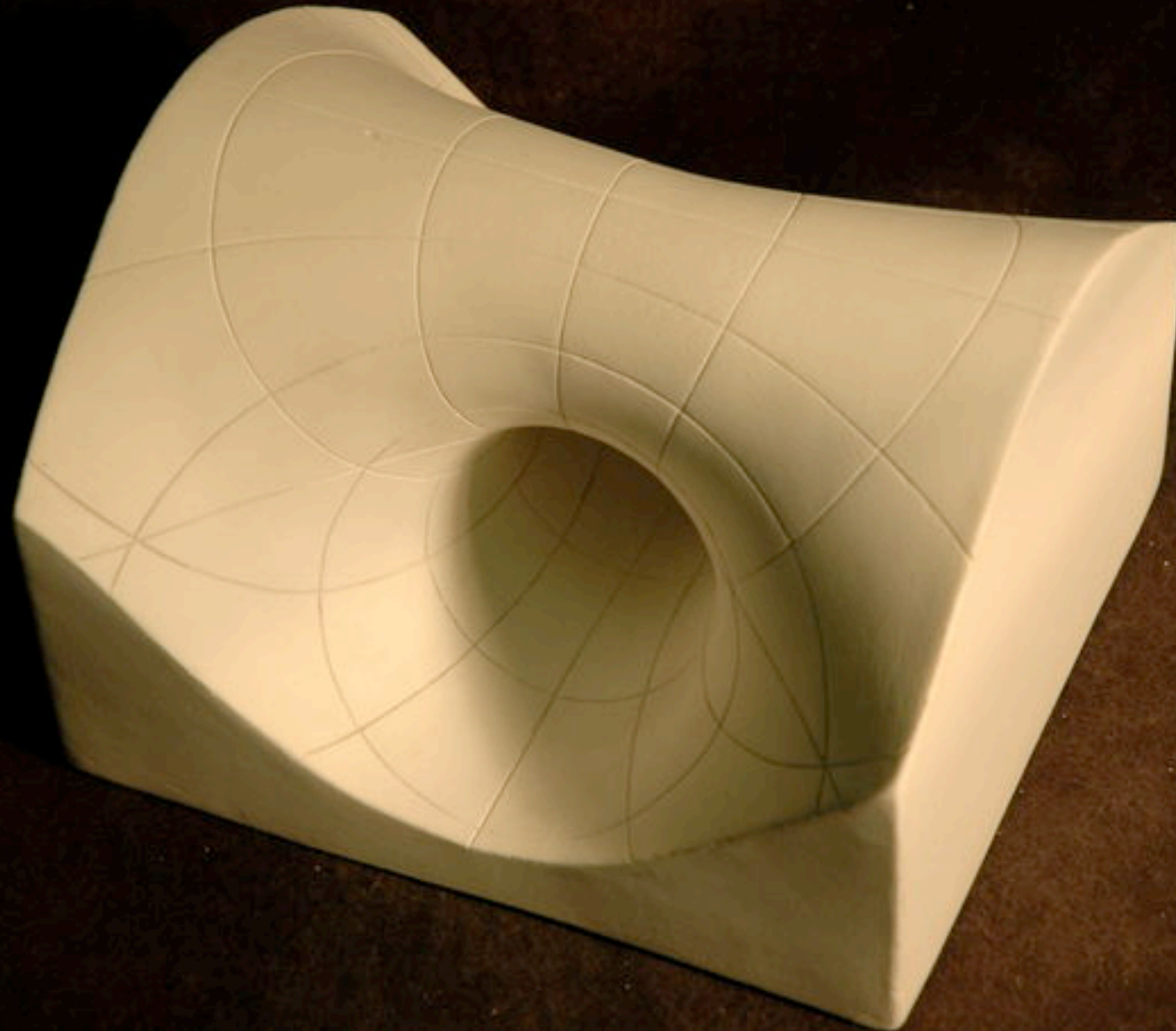

University of Illinois at Urbana-Champaign: Collection of mathematical models



University of Illinois at Urbana-Champaign: Collection of mathematical models



University of Illinois at Urbana-Champaign: Collection of mathematical models

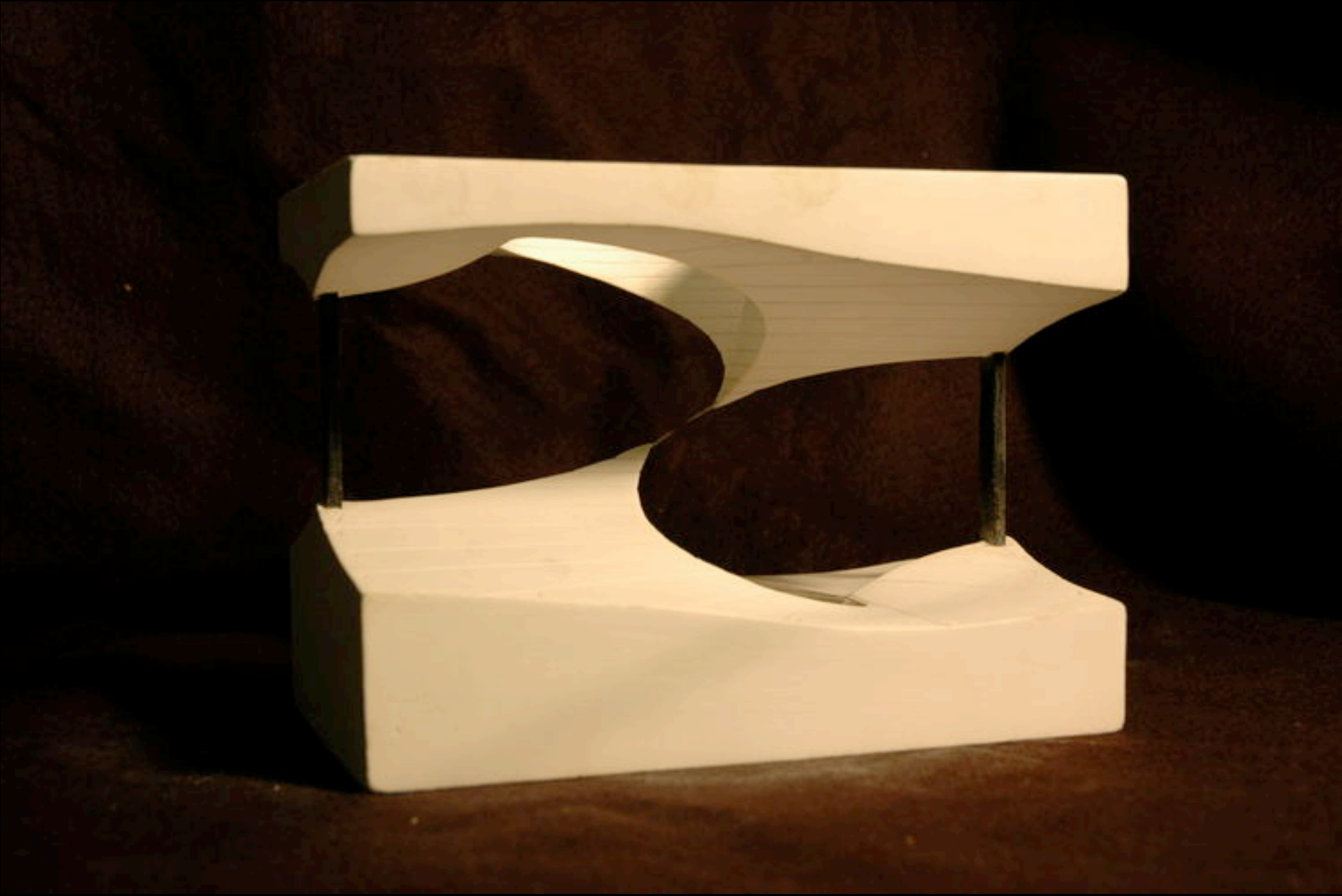

University of Illinois at Urbana-Champaign: Collection of mathematical models

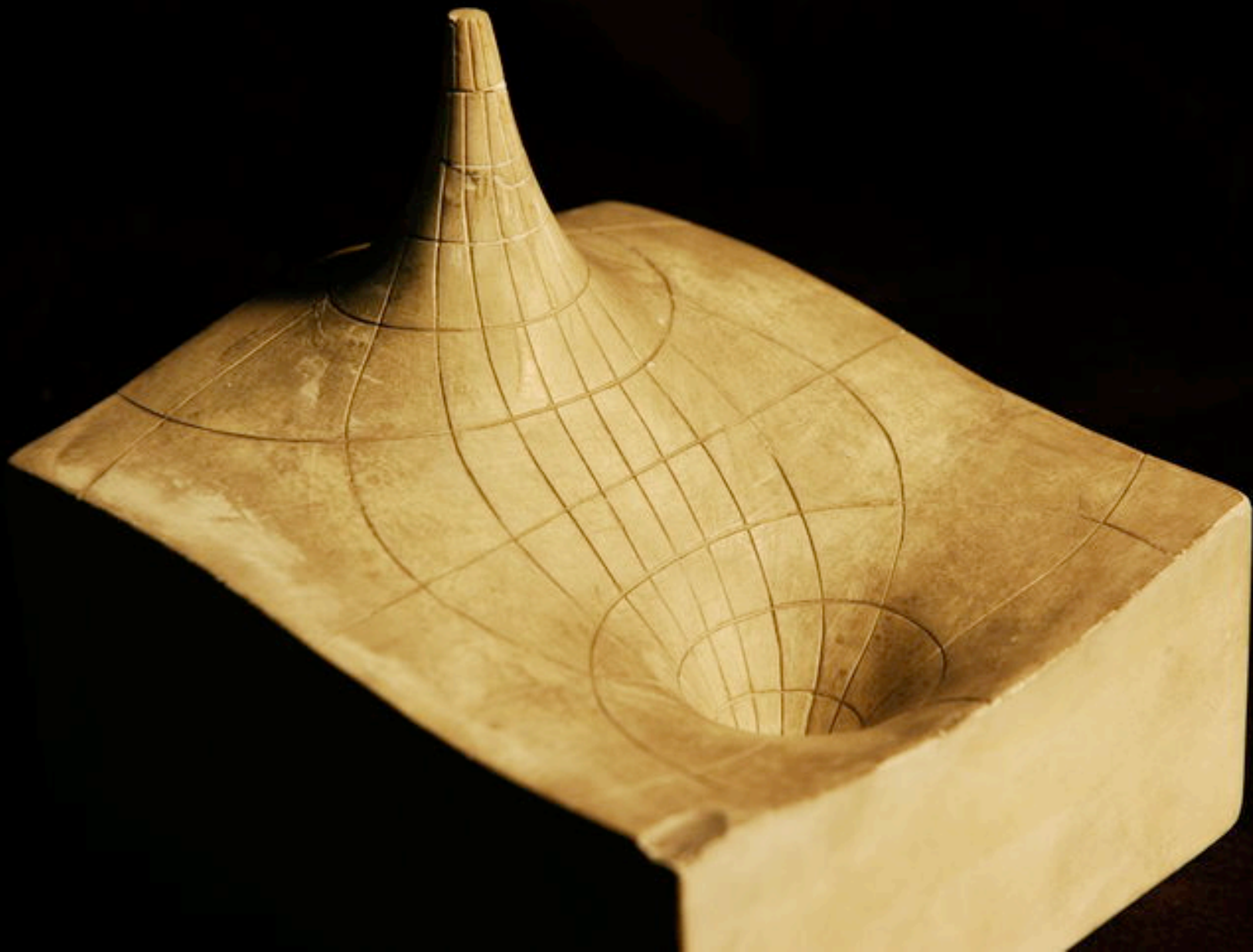

University of Illinois at Urbana-Champaign: Collection of mathematical models



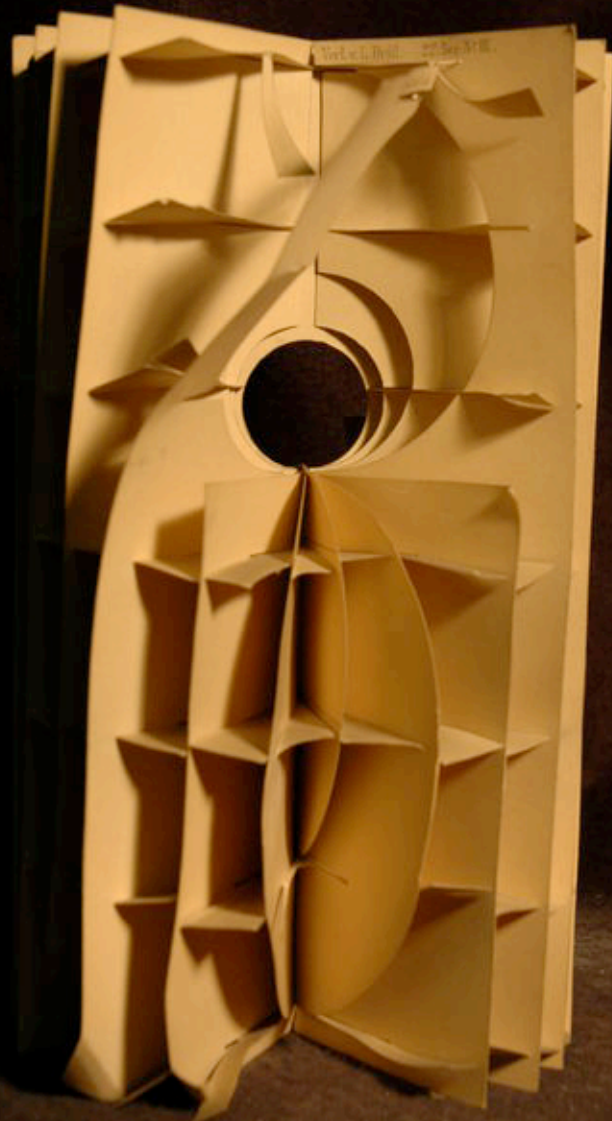

University of Illinois at Urbana-Champaign: Collection of mathematical models



University of Illinois at Urbana-Champaign: Collection of mathematical models

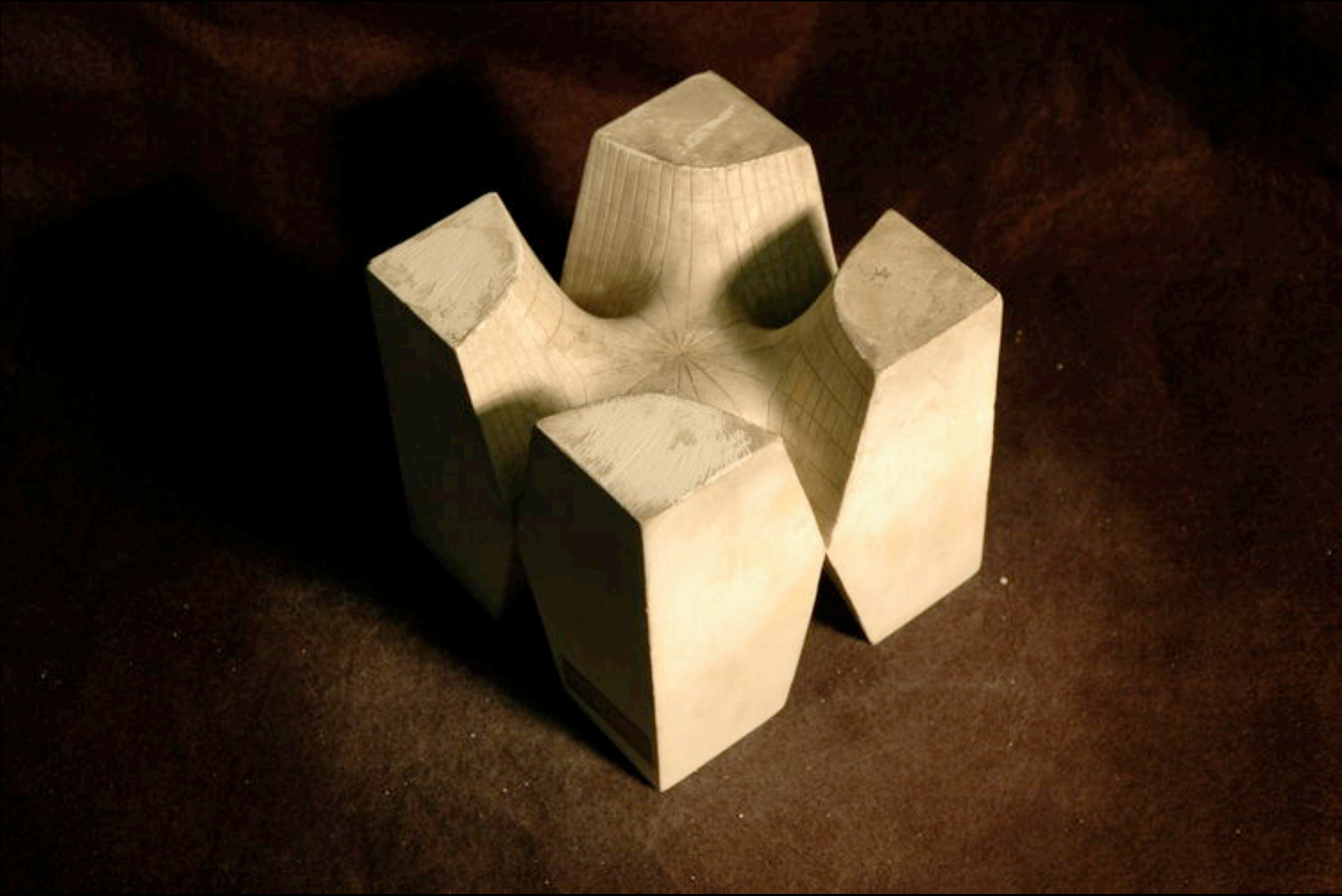

University of Illinois at Urbana-Champaign: Collection of mathematical models

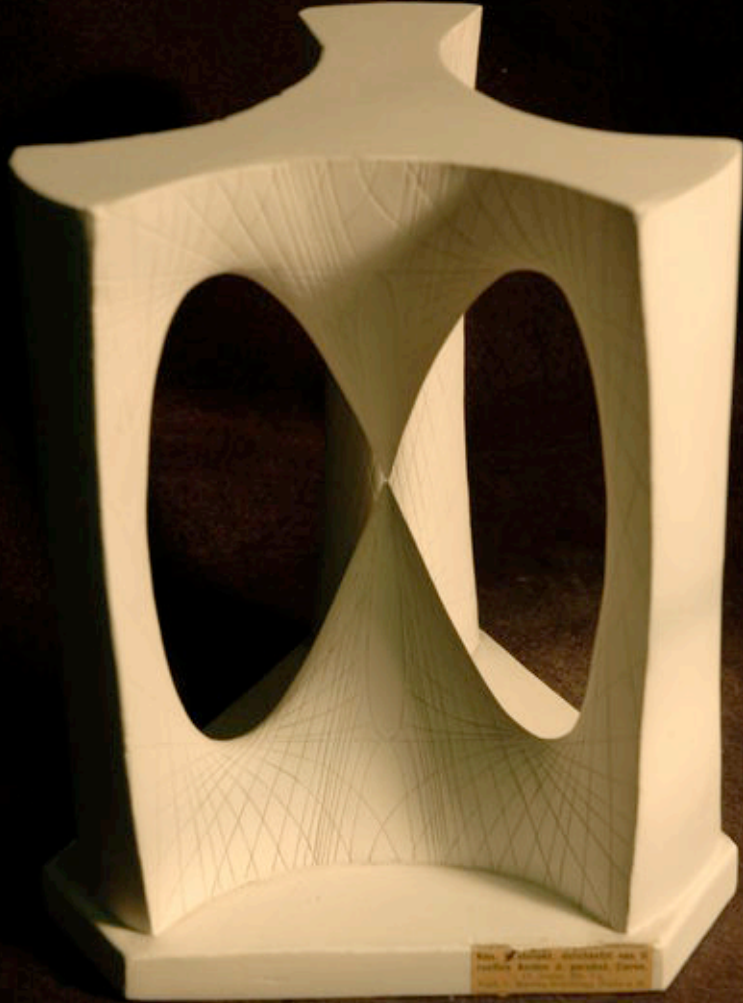

University of Illinois at Urbana-Champaign: Collection of mathematical models



Man Ray: "Shakespearean Equations", 1948



Man Ray: "Shakespearean Equations", 1948



Man Ray: "Shakespearean Equations", 1948



Man Ray: "Shakespearean Equations", 1948





Man Ray: "Shakespearean Equations", 1948

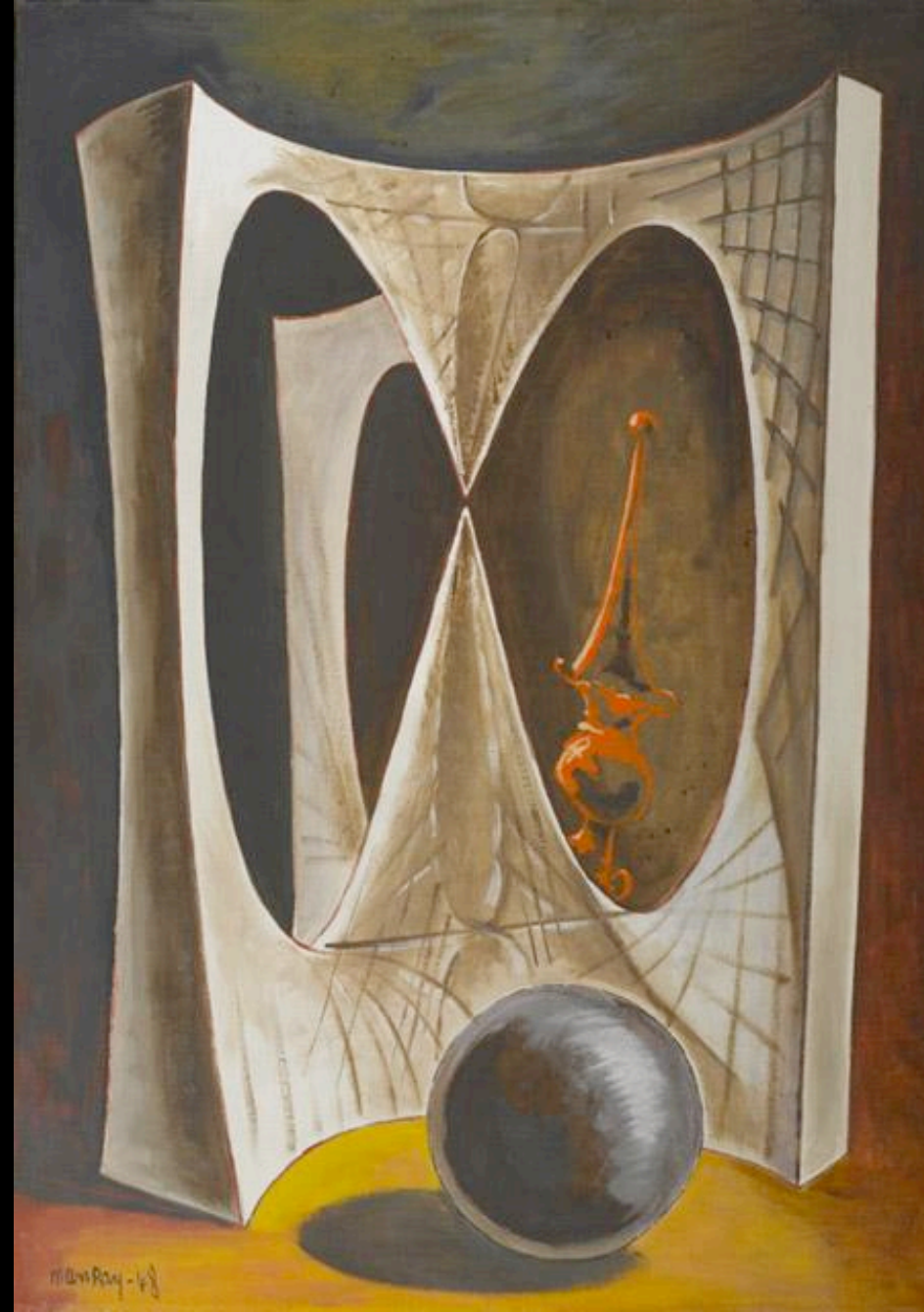

Man Ray: "Shakespearean Equations", 1948



Man Ray: "Shakespearean Equations", 1948

Generative art

A simple and fascinating way to DRAW a million marvelous patterns

# Kenner's NEW SPIROGRAPH

For all ages... Anyone can draw beautiful patterns immediately!  
Create your own and use the SPIROGRAPH Booklet

No limit to the different designs you can make!

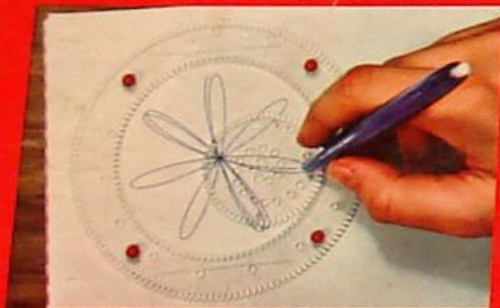

Perfect "mesh" of the wheels, rings and racks. You hold the pen yourself and actually draw the pattern.

- SPIROGRAPH SET contains:
- 18 Transparent Plastic Wheels
  - 2 Transparent Plastic Rings
  - 2 Transparent Plastic Racks
  - 4 Ball point Pens - Red, Blue, Green, Black
  - Baseboard and Pack of Paper
  - Patent Storage Tray for Wheels, Rings, Racks, Pins and Pens
  - 16-page full-color illustrated Pattern Booklet with easy instructions.

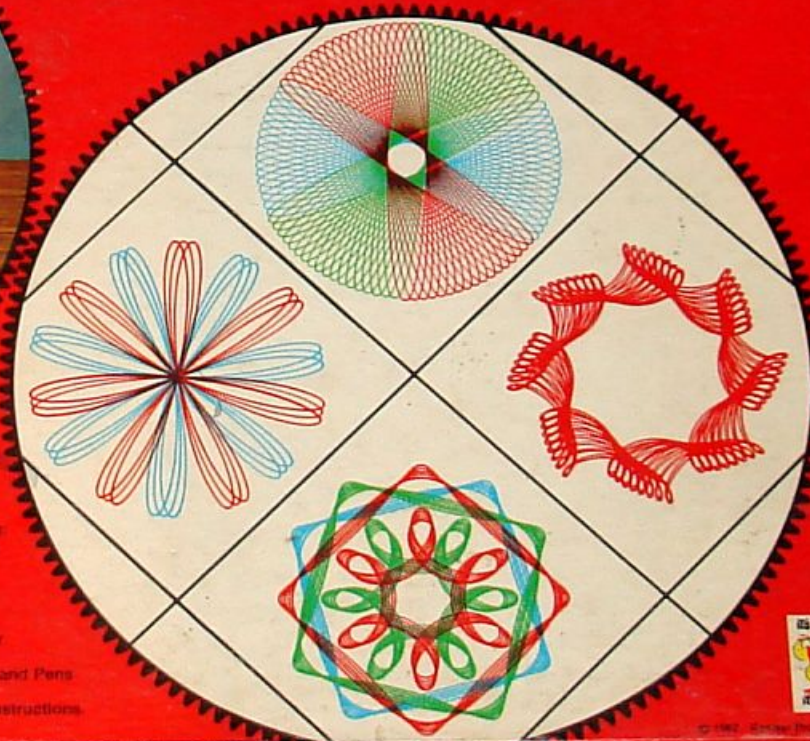

A simple and fascinating way to DRAW a million marvelous patterns

Kenner's No. 401

# SPIROGRAPH

Anyone can draw beautiful patterns immediately!



Spirograph toy set

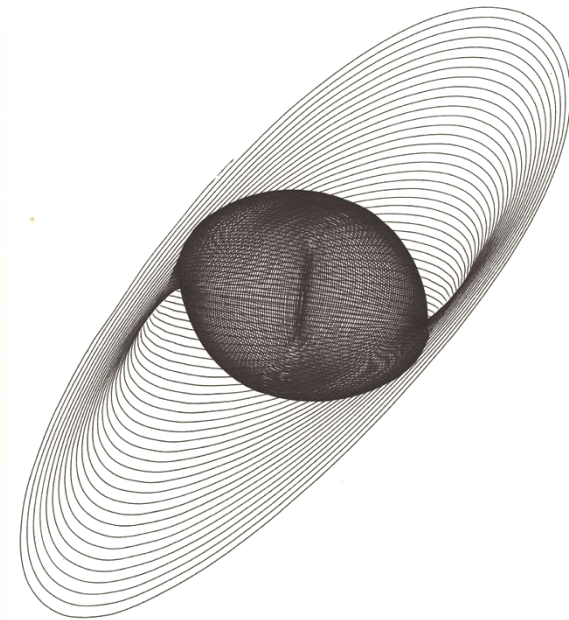
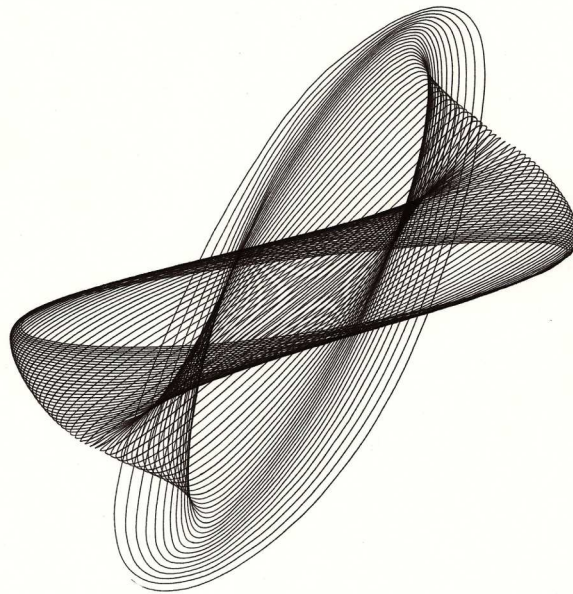
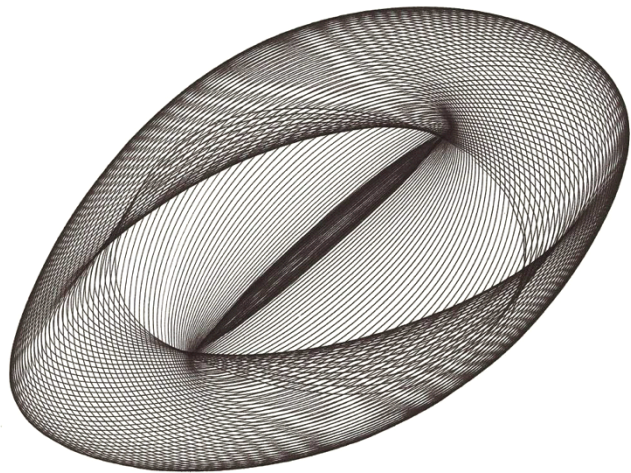
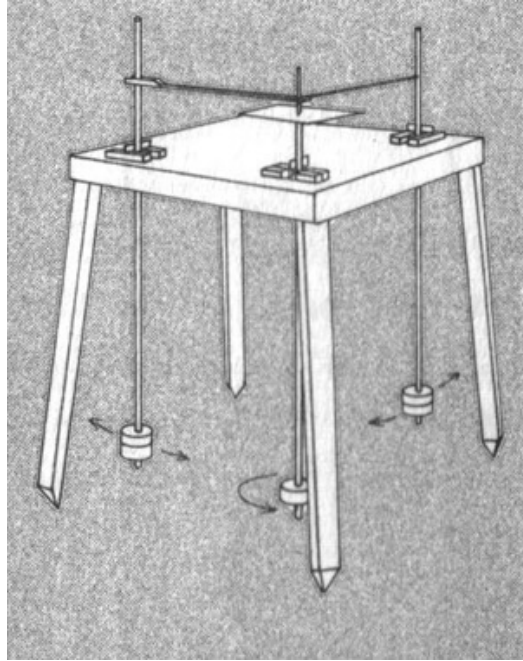

Three-pendulum harmonograph

Harmonographs:

<http://www.youtube.com/watch?v=yDfdYoGyM7E>

<http://www.youtube.com/watch?v=2DjvtjgRdGA>

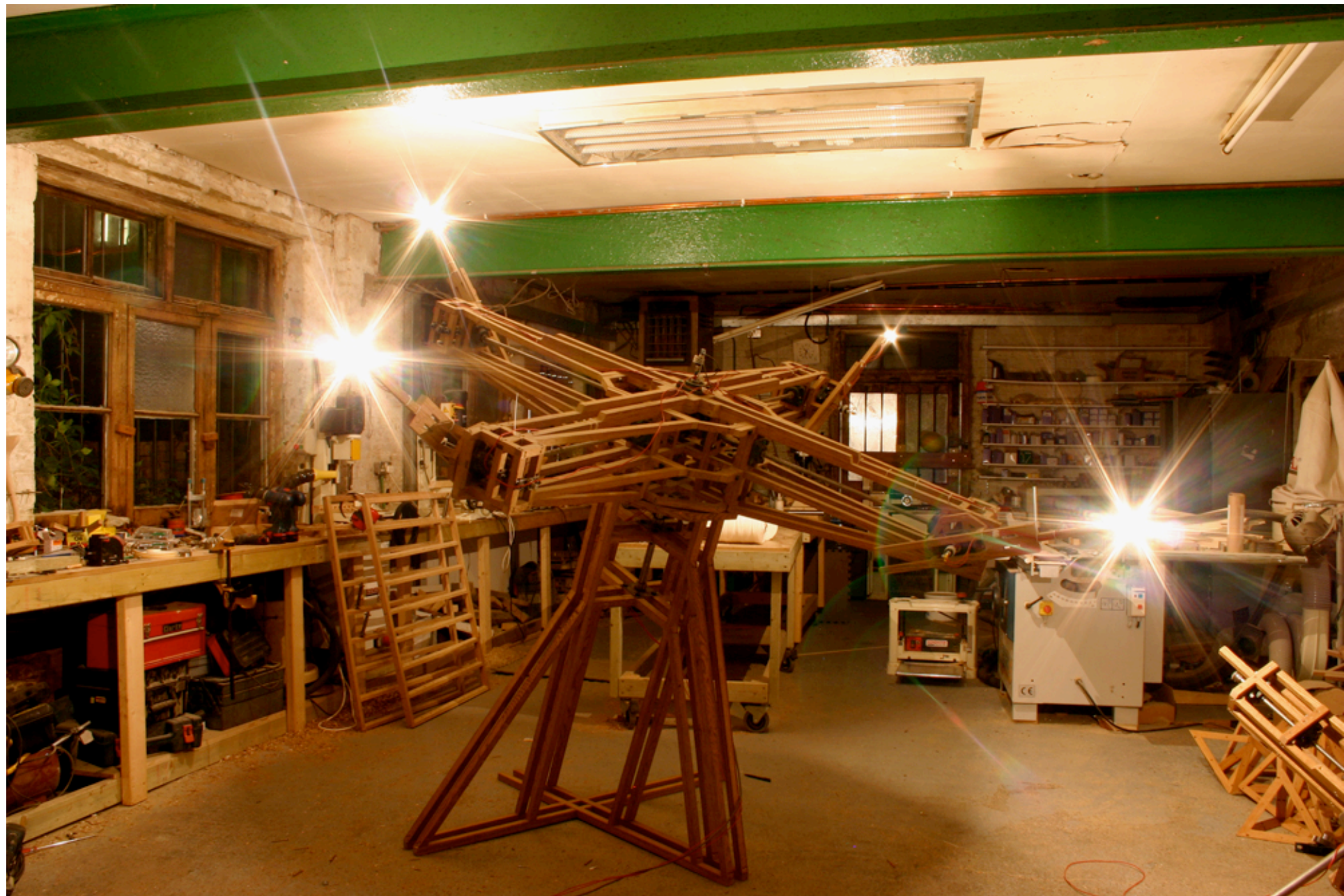

Conrad Shawcross: "Counterpoint", 2006





Conrad Shawcross: "Counterpoint", 2006

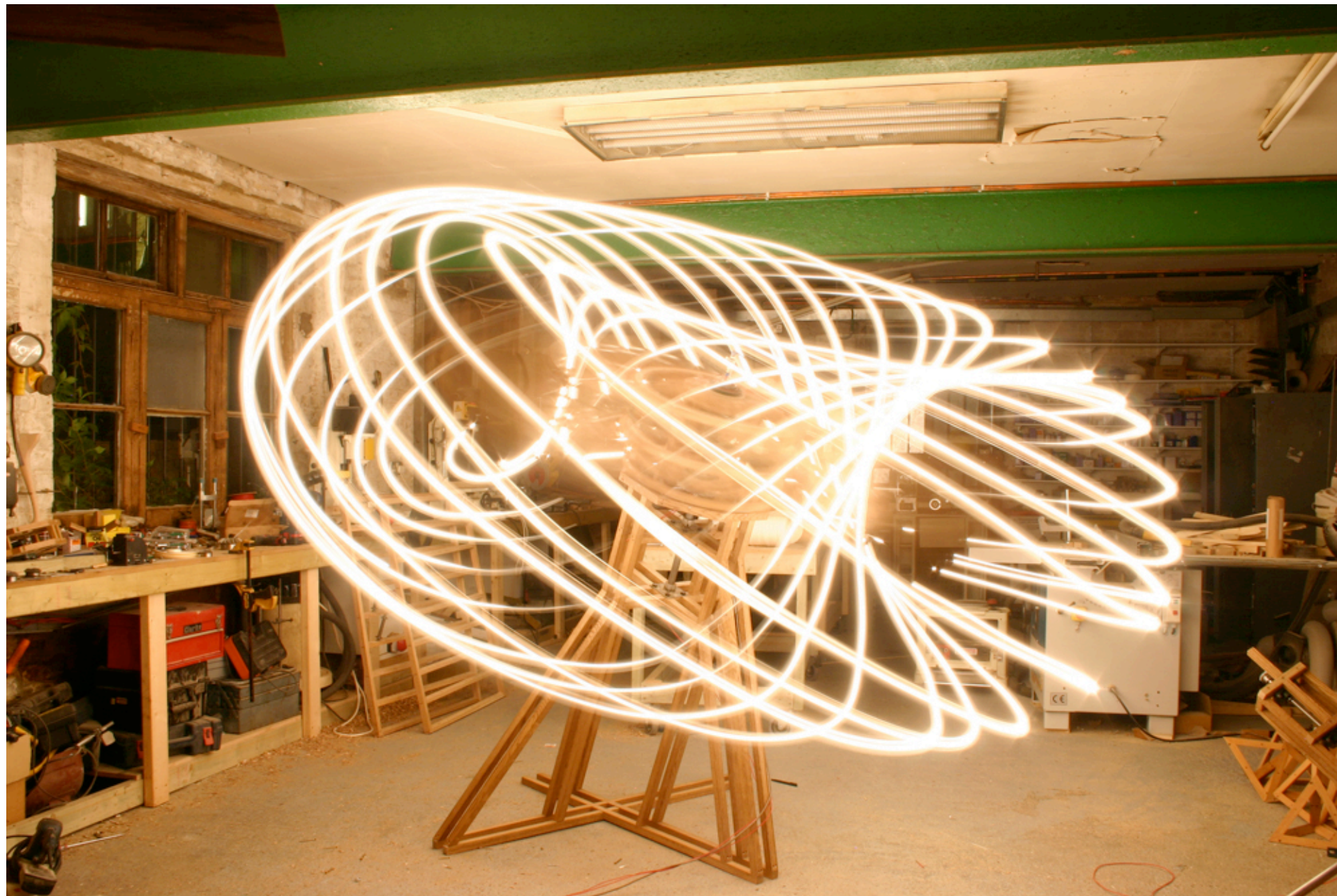

Conrad Shawcross: "Counterpoint", 2006

## John Conway: "Game of Life"

### Rules:

1. Any live cell with fewer than two live neighbours dies, as if caused by under-population.
2. Any live cell with two or three live neighbours lives on to the next generation.
3. Any live cell with more than three live neighbours dies, as if by overcrowding.
4. Any dead cell with exactly three live neighbours becomes a live cell, as if by reproduction.

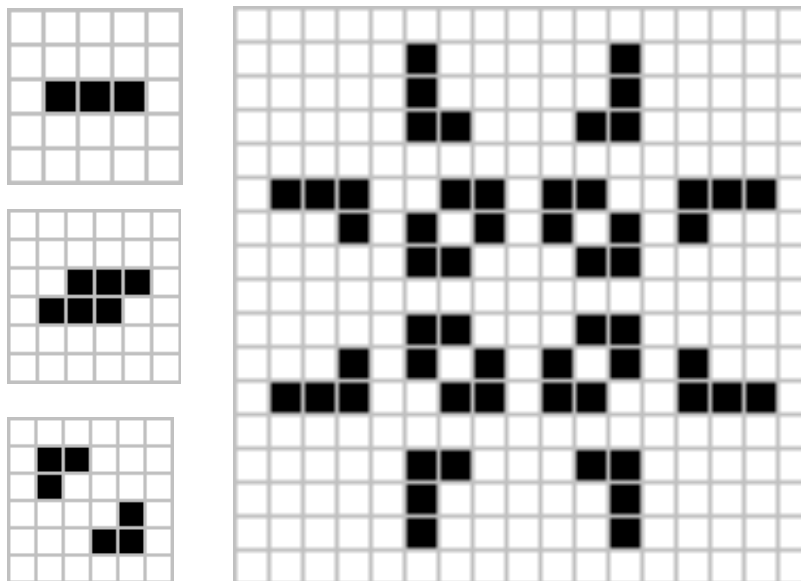

John Conway: "Game of Life" (Oscillators), 1970



John Conway: "Game of Life" (Gosper's Glider Gun), 1970

Group discussion