



# CHAPTER

# BOOK

FIGHTING AIDS | HEALTHCARE FOUNDATION

CHAPTER

# 6.0

Streetscape Elements

- 6.1 Urban Forest
- 6.2 Stormwater Management Tools
- 6.3 Lighting
- 6.4 Paving
- 6.5 Site Furnishings
- 6.6 Utilities and Driveways

# GUIDE: STREETSCAPE ELEMENTS

Trees and landscaping, lighting, pedestrian furnishings, paving, and other elements fill the spaces of the streetscape with life, light, color, and texture and make a street a comfortable, interesting, and usable space for people.

**Streetscape elements are those functional and aesthetic items in pedestrian spaces that provide amenity and utility to pedestrians and other street users.**

Streetscape elements discussed in this chapter include:

**Urban Forest:** All plantings in the right-of-way, including street trees, understory planting (ground landscaping), and above-ground planting (planter boxes and hanging baskets)

**Stormwater Management Tools:** Plantings, permeable paving, and other facilities to retain, detain, convey, infiltrate, and treat stormwater

**Lighting:** Both roadway and pedestrian lighting, including poles and fixtures, and light quality

**Paving:** Standard materials as well as special paving treatments

**Site Furnishings:** Other pedestrian amenities and functional elements, including: benches and seating, bicycle racks, bollards, flowerstands, kiosks, newsracks, parking meters, public art, sidewalk restrooms, traffic and parking signs, trash receptacles, and signage and gateways

**Utilities and Driveways:** Overhead, surface-mounted, and sub-surface utilities including all poles, trenches, boxes, vaults, vents, and valves, and driveways to access properties.



# Urban Forest

## 6.1

The following section provides general principles that should guide how the City considers its urban forest, which includes all trees and landscaping. Recommendations for street trees and landscaping elements are provided in specific sub-sections.

### ➔ In this section: Urban Forest

- Street trees
- Understory landscaping
- Above-ground plantings

The urban forest includes any landscaping planted in the public right-of-way, including trees, understory plantings, and above ground plantings. Planting in the public right-of-way enhances the physical, ecological, and cultural aspects of the city, including:

- ➔ **Environmental:** Trees and landscaping make important contributions to the urban environment by reducing air pollution, ameliorating urban heat islands, improving hydrologic conditions, sequestering carbon, and contributing to wildlife habitat. Use of drought-tolerant trees and landscaping can aide water conservation efforts.
- ➔ **Economic:** Trees and landscaping can increase property values, increase commercial spending, and reduce maintenance costs of other streetscape elements.

- ➔ **Aesthetic:** The visual characteristics of street trees and landscaping (form, color, texture) add greatly to the aesthetics of urban streets and can enhance the civic qualities of the public environment.
- ➔ **Psychological:** People derive psychological benefits from symbolic and physical contact with nature provided by a green environment. A planted streetscape provides relief from an otherwise built out urban environment.
- ➔ **Social:** Opportunities for new social contacts, community identity, and the opportunity to contribute to the establishment and care of a community feature are afforded by the presence of street trees and planting.
- ➔ **Safety:** Consistent tree plantings along a street narrow the perceived width of a street, encouraging decreased vehicular speed and increased awareness of pedestrians.

▼ Moraga Street



**GUIDELINES**

Selecting Plant Types

Street trees and other landscaping should be used to create a distinct character for specific streets and neighborhoods. Trees and landscaping should be designed in harmony with street lighting and sidewalk amenities and the building context. Trees and plants vary in their aesthetic appearance due to variations in form, texture, foliar density/visual permeability, seasonal presence of flowers, seasonal color, bark characteristics, and persistence of leaves (evergreen vs. deciduous). Aesthetic appearance should be taken into account in making design decisions for the public right-of-way. New planting added to existing streets should be in visual harmony with existing trees and planting. Selection of planting material should be used to enhance the identity of streets important to the city pattern.

In view of global climate change, consideration should be given to future watering needs and heat resistance of species selected for planting. Landscape practices should follow xeriscape principles and drought-tolerant species should be used to meet the increased dryness associated with the anticipated future climate of San Francisco.

Plant material selection should account for performance in the urban environment, including drought tolerance and hardiness. Unfortunately, many native species do not do well in harsh urban conditions. Any plant species selected for planting should be adapted to soil and microclimate conditions and should serve an intended functional or aesthetic role. In some cases, the drought tolerant character of some native species may make them particularly suited for planting; however, past performance of the species in terms of durability, longevity, wind resistance, and high branching to provide line-of-sight for pedestrians and vehicles should also be considered. Native plants and trees should

be considered when a native species is suited to the site and will serve the roles for which the planting is intended. They should also be considered for stormwater plantings, areas of habitat value or connections, or for educational purposes.

Evergreen tree species should be used where it is desired to maintain foliage through the winter months or to enhance ecological performance by allowing leaves to slow stormwater during the rainier season. Deciduous trees should be considered for their ability to allow sunlight in the winter months

Climate and Soil

Placement of trees and landscaping should reflect an understanding of local soil and climate conditions. Recommended trees for different San Francisco environments have been developed both by the Department of Public Works (Bureau of Urban Forestry) and the Friends of the Urban Forest in relation to the environment identified in the microclimates map.

Before planting, current soil conditions should be evaluated and the soil amended to create the most beneficial growing conditions for trees and landscaping. Mulches should be considered to reduce erosion and decrease soil desiccation.

Engineered soils (for example structural soil), which can contribute to better tree health while protecting paved surfaces from root damage, may be appropriate in some locations.

**OTHER CONSIDERATIONS**

**Stormwater management:** The design of planting areas should consider including appropriate conditions for improved stormwater detention and infiltration. See Section 6.2. See also the Stormwater Design Guidelines Vegetation Palette for planting ideas.

▶ Existing sidewalks may be retrofit to include simple but attractive planting areas





**Reuse of underused right-of-way space:** Many spaces that occur within the public right-of-way may be considered for trees and other plantings. These spaces include traffic circles, excess space where two street grids intersect, parking lane planters, and other unique spaces. In some cases, small groves of trees may be planted in these reclaimed spaces at a greater density than would be typically possible for street trees. See section 5.8.

**Culturally-sensitive plantings:** The variety of cultural backgrounds of the people living in San Francisco should be considered in the selection and planting of trees in certain neighborhoods and adjacent to particular civic buildings. For example, in neighborhoods with a relatively high density of residents of Chinese descent, tree plantings might adhere to the principles of 'feng shui'. Other ethnic groups place particular value on certain tree species and would like to see them planted in their neighborhoods. Outreach to different cultural groups should be incorporated into site specific plans for tree planting in the public right-of-way.

**Urban forest as habitat:** A variety of native and exotic wildlife species make use of trees and landscaping in the city. Trees and landscaping provide cover, nesting sites, food, and a source of water. Street trees and landscaping provide corridors for the movement of many species and serve as important links between parks and open spaces throughout the city. Future tree planting and street landscaping projects should consider existing linkages between parks currently provided by street trees and address gaps by locating new plantings in a supportive way.

**Personal security:** Personal security of people using the public right-of-way is influenced by trees and other plantings. Trees and shrubs that do not obstruct views, interfere with street and pedestrian lighting, or block potential escape routes enhance personal security. Trees and shrubs should be pruned and maintained to ensure good street level visibility and avoidance of interference with street and pedestrian lighting. Box hedges over 3 feet in height should be avoided, as they may obscure visibility or constrict paths of travel.



➔ Soils and Microclimates Map

**THE COASTAL ZONE**

AREA 1: Cool temperatures; foggy to clear days; light winds; sand and loamy soils

AREA 2: Cool to moderate temperatures; foggy to clear days; light winds; sandy and loamy soils

AREA 3: Cool temperatures; foggy; salt air; heavy winds; sandy soil

**THE TRANSITION ZONE**

AREA 4: Cool to moderate temperatures; foggy to clear days; light winds; sand, clay, loam, rock soil

AREA 5: Cool to moderate temperatures; clear days with lightfog; light winds; sand, clay, loam, rock soil

**THE BAY ZONE**

AREA 6: Moderate to hot temperatures; clear days; light winds; sand, clay, loam, rock soil

AREA 7: Moderate to hot temperatures; clear days; heavy wind; sand clay, loam, rock soil

## Street Trees

Street trees are the most important organizing element of the streetscape environment. Appropriate tree species selection and location and design of the planting site will ensure the healthy growth and longevity of trees, enhance streetscape character, and maximize the City's investment. It has been demonstrated that street trees enhance property values in residential neighborhoods and commercial areas.

### ➔ PLACEMENT

Street trees are typically planted in tree basins (sidewalk cut outs) in sidewalks. Where planting strips of sufficient width occur between sidewalks and streets, it is not necessary to create independent tree basins for trees. Ground-cover landscaping should be included in planting basins larger than standard size. In limited circumstances, trees may also be planted in above ground planters. Planting strips and above ground planters are addressed in the following sections.

When adding trees to an existing streetscape, movable site furnishings should be relocated, where feasible, to allow for street tree planting in an appropriate spacing. If unmovable sidewalk elements interfere with a planting sequence, site the tree a few feet in either direction to accommodate obstacles. When designing a new or renovating an existing street, locate or relocate utilities and other elements where feasible to attain a regular tree spacing.

### ➔ GUIDELINES

#### Species Selection

Tree species selection and placement should be consistent with the goals of a particular street. See Section 4.1: Street Types.

Ceremonial streets, commercial streets, major throughways, and other streets important to the city pattern should use

formal, consistent planting palettes chosen for their distinct design qualities to provide a strong aesthetic character and facilitate place recognition. Neighborhood residential or smaller streets may use a more diverse, less formal planting palette to indicate neighborhood preference and create a rich planting variety. On DPW maintained streets, the Bureau of Urban Forestry may require specific tree species.

Consistent plantings, flowering species, and accent trees add aesthetic value. Accent trees, distinguished by their contrasting color, texture, or size, may be used to alert motorists to approaching intersections or mark the entrances of city parks and plazas.

On formal streets with sufficient width, allées—a double row of trees—should be used to create a distinctive design.

Appropriate tree species selection should consider:

- ➔ form, mature size, color, and texture to reflect the urban design goals of a street;
- ➔ the mature tree canopy with respect to how it may affect street and pedestrian lighting or views of signage and building fronts;
- ➔ the potential for root systems to affect sidewalks, curbs, and utilities ; and
- ➔ impacts and constraints created by local climate.

Generally:

- ➔ Trees with columnar form are appropriate for narrower planting spaces such as small streets, alleys, and narrow medians.
- ➔ Trees with overarching canopies and medium density foliage are appropriate on wider streets, such as mixed-use streets, throughways, and boulevards.
- ➔ Medium-sized trees with light to medium density foliage are appropriate on neighborhood residential and commercial streets.

### Size

Minimum size requirements for trees to be planted in tree basins in the sidewalk are as follows:

- ➔ Caliper (trunk diameter) of trees to be planted should be a minimum of 2 inches at 8 feet of height (exceptions should be considered for desired species that may not attain this caliper size as a 24-inch box specimen).
- ➔ Minimum tree size at planting is a 24-inch box; 15-inch box specimens and smaller caliper sizes should be allowed for volunteer efforts and property owner initiated replacement.
- ➔ Tree branches that extend into the path of travel must maintain 80 inches of vertical clearance.

### ➔ Characteristics of Trees for Different Climatic Zones

The city may be divided into three climatic zones: Coastal (Fog Belt), Transition, and Bay (Sun Belt). The Coastal Zone is characterized by cool temperatures, dense summer fog, and prevailing westerly winds. This zone is best divided into a coastline and interior zone due to differences in wind exposure and salt laden air; consideration should also be given to the orientation of streets, as east-west running streets generally experience more wind exposure. The Transition Zone has cool to moderate temperatures, light fog, sunny skies, and diminished wind velocities. The Bay Zone supports warm temperatures, skies that are dry, clear, and sunny, and generally light winds.

- General characteristics of trees best adapted to the Coastal Zone include trees of lower stature (up to 25 feet tall), evergreen species, and trees that are wind tolerant.
- Trees for the transition zone need some wind resistance, should be of medium stature (25 to 50 feet tall), and may be either deciduous or evergreen.
- The Bay Zone provides an environment more suited to a wider variety of trees. Trees that may be used include those of taller stature (over 50 feet tall) and those not noted for wind resistance, unless planted at higher elevation sites within the Bay Zone, which are subject to higher velocity winds (e.g., portions of Bernal Heights, Nob Hill, and Telegraph Hill).

## Location and Spacing

Street tree spacing should be determined by the expected mature size of the tree. Generally, trees should be planted with the following spacing:

- Small trees (<20 feet crown diameter at maturity) should be planted 15 to 20 feet on center.
- Medium sized trees (20 to 35 feet crown diameter at maturity) should be planted 20 to 25 feet on center.
- Large trees (>35 feet crown diameter at maturity) should be planted 35 feet on center.

These guidelines may suggest a crowding of the canopies of adjacent trees, but trees will adapt to a slight degree of crowding and still remain healthy. Slight crowding will insure a continuous tree canopy along the street. Certain trees, such as palms and many ornamental species may be used on ceremonial streets, although they may not result in a continuous canopy.



Tree spacing should create a continuous canopy and buffering effect between the roadway and the sidewalk. Closer spacing is desirable on heavily traveled streets to create a palisade view looking down the sidewalk.

These spacing guidelines should be considered general targets that may be adjusted to local street conditions such as setbacks from corners, utilities, driveways, bus stops, and building entrances. To the greatest extent feasible, trees should be aligned to minimize interference with building entries, driveways, and utilities.

Where site constraints prevent maintaining an exact spacing, it is favorable to place a tree slightly off the desired rhythm than to leave a gap in the planting pattern.

Tree basins should be aligned so that the edges abutting the path of travel form a straight line along the block.

**Trees adjacent to streetscape elements:** Minimum guidelines for sidewalk element clearance from street trees (not ground landscaping) on a public sidewalk are:

→ Parking Sign	3 feet
→ Utility Boxes	3 feet
→ Parking Meters	3 feet
→ Pedestrian Furniture	3 feet
→ Sewers	5 feet
→ Fire Hydrants	5 feet
→ Traffic Sign	5 feet
→ Utility Poles	5 feet
→ Fire Escapes	10 feet

- ▲ Trees should be planted as near to corners as is practicable while retaining visibility

### **Trees adjacent to accessible parking and passenger loading zones:**

Street trees are not allowed adjacent to an accessible parking and passenger loading zones when the sidewalk is less than 12 feet wide. Street trees may be planted in these zones so long as 8 feet minimum clear from curb face to tree basin edge is maintained for the length of the zone.

**Trees at intersections:** Trees are especially valuable to pedestrians at intersections. Without street trees, intersections can be overwhelmingly large expanses of asphalt. The desire for trees should be balanced with concerns for sight distance and clear views of traffic control devices and street and pedestrian lighting requirements. Strategic placement and effective pruning of trees can improve pedestrian and motorist conditions and safety at intersections.

In order to maximize visibility of pedestrians waiting to cross the street and traffic signs and signals, trees within 25 feet of the corner property line on approach and 10 feet of the property line on exit, as traffic flows, should be pruned to ensure a 14 foot minimum height of the lowest branch. Trees adjacent to intersections should be large species with high branching canopies to maximize visibility and visually enclose the intersection.

Street trees should not be planted closer than 5 feet from the near side edge of the crosswalk. Landscaping may be planted within this zone using plant material with a maximum mature height of 3.5 feet above the roadway.

See DPW Director's Order #169,946 on tree planting.

**Trees adjacent to bus zones:** Trees can provide welcome shade at transit stops and a continuous canopy along the street, but should not interfere with the ability of people to board transit vehicles at stops. Trees adjacent to curbside bus zones should accommodate access to the bus doors. Trees should be planted no closer than 6 feet from a bus shelter. Trees should be planted in bus zones per the dimensions as shown in Figure 6.1. To reduce tripping hazards and maintain accessibility to the bus, individual tree basins should have a metal tree grate, or if placed in a continuous trench, the trench should be covered with an ADA-compliant surface material.



**Trees in Medians:** Trees may be planted in medians 4 feet or wider, including curbs. Trees planted in medians should have arching canopy structures that provide visibility without excessive pruning, or be upright and columnar in form. Tree species selected for planting on median strips that are 4 to 6 feet wide should be expected to grow to trunk diameters no greater than 12 inches. On median strips greater than 6 feet wide, trees obtaining larger diameters may be used.

Trees located in medians should have a vertical clearance of the lowest branch of 8 feet in height over the median, and 14 feet in height for any portion of the tree that overhangs the roadway. Shrubs located in the median should not exceed 3.5 feet above the roadway.

**Coordination with street lighting:** Street lighting should be coordinated with tree selection, placement, and pruning, so that tree canopies do not sit directly below street lighting. See Section 4.2. Overall Streetscape Guidelines, for detail. For new streets where lights and trees are being placed, street lights should be generally placed halfway inbetween trees. When trees are being added to an existing streetscape, the basin pattern should respond to the location of existing lighting.

**Trees and building projections:** The width of the fire escape balcony, projected down to the sidewalk, should remain clear of any trees or landscaping. Awnings, canopies, signs, and marquees may also present conflicts with street trees. New building projections should not compromise tree health or potential tree planting locations.

Size of Tree Basins

Trees need adequate surface area for root growth. Most tree species have the majority of their roots in the first 18 inches of soil. An important variable in tree basin design is the amount of surface area. Greater surface area provides for greater entry of water and oxygen into the soil.

Tree basins should meet the following the minimum size shown in Figure 6.3.

Basins may be square, rectangular, or have other shapes to meet the minimum size requirements. Linear planters may enable a design to achieve optimal tree basin size on narrow sidewalks.

Permeable surfacing increases access of tree roots to water and oxygen when the optimal tree basin size is not possible. Continuous trenching between tree basins (which can be covered by paving) should be used wherever possible to maintain the capacity of oxygen and water to enter the soil in a tree basin, particularly where minimum sized tree basins must be employed.

Far Side Bus Stop

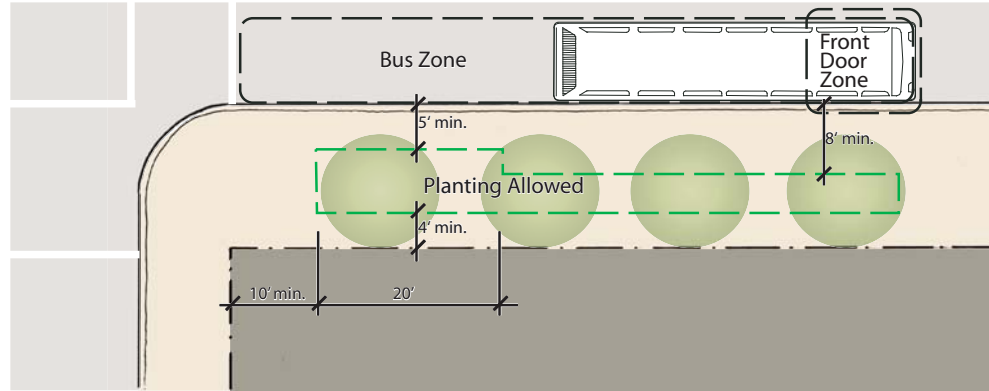
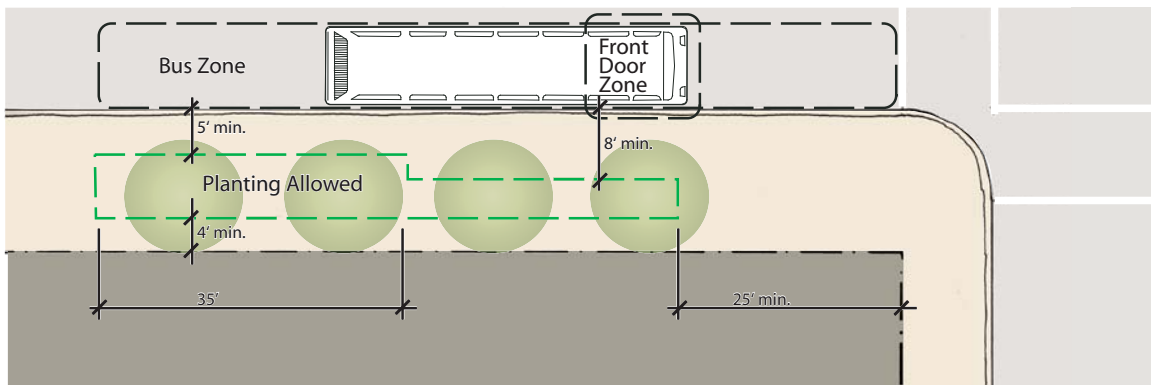

FIGURE 6.1  
TREE PLANTING  
IN BUS ZONES

Near Side Bus Stop



► Trees in medians can provide a fuller canopy and visually narrow the street



FIGURE 6.2  
TREE CLEARANCE FROM STREET LIGHTS

SIZE OF TREE (At Maturity)	CLEARANCE
Small	No closer than 9 feet
Medium	No closer than 15 feet
Large	No closer than 21 feet

FIGURE 6.3  
MINIMUM BASIN SIZE

SIDEWALK WIDTH	STANDARD BASIN SIZE
6 1/2 to 7 1/2 feet	2 x 4 feet*
7 1/2 to 12 feet	3 by 4 feet
12 to 13 feet	4 by 4 feet
13 feet and wider	5 by 5 feet

\*Note: In this basin size, only small (upright) tree species, at maturity, should be planted as approved by DPW, Bureau of Urban Forestry



◀ Using cobbles or other paving stones protects the basin and still allows root access to water

Tree basin size should vary with the mature size of the tree species and soil conditions. Larger basins should be provided for larger trees where space permits.

### Grade and Surfacing

Landscaping with drought tolerant groundcovers, non-woody shrubs, or grasses is encouraged within the tree basin. Open soil in tree basins is discouraged. When landscaping is not used, the open basin area surrounding the base of the tree should be filled with sand set paving stones, cobbles or compacted decomposed granite (DG) to maintain a level surface.

Tree basin grade should be maintained at existing sidewalk grade.

- **Sand set paving stones or cobbles:** Where sand set paving stones or cobbles are used, they should generally be placed outside the root ball.
- **Decomposed granite (DG):** To account for settling of soil and DG, additional DG may need to be added during scheduled maintenance.

### Tree Basin Furnishings

**Tree Grates:** Tree grates and other structural basin covers are generally discouraged, as over time, they can become an obstacle or tripping hazard and can interfere with the diameter growth of trees, resulting in girdling and damage to trees. Maintenance of tree grates is costly, often requiring workers to expand the diameter of the opening as the girth of the trunk increases.

In limited locations, such as heavily traveled sidewalks where sidewalk width limits pedestrian movement at peak times, where a formal design treatment is desired, such as along ceremonial streets, or in bus zones, it may be necessary or desired to install tree grates to provide an adequate walking surface or design treatment.

Grates should be designed with easily removable inner rings to allow for the growth of the tree trunk. In limited circumstances such as extremely narrow sidewalks, tree grates may be counted toward the minimum clear path of travel; however, as they are difficult to maintain to an accessible standard, this is not a preferred solution.

Grates should have less than 1/2 inch spacing between rings to provide a safer walking surface and to prevent material from being trapped or falling into the basin.

Maintenance of grates used in high pedestrian traffic areas should include the periodic cleaning of grates and adjustment to eliminate any tripping hazard.

**Tree guards:** Tree guards are generally discouraged, but may be appropriate on heavily traveled sidewalks for the protection of newly planted trees. They are also appropriate adjacent to heavily used bus and light rail stops, around school buildings, and adjacent to other land uses with associated activities that may be considered detrimental to tree health and safety.

Tree guards should be of an attractive design, not possess any sharp edges, and be made of durable material. Tree guards should be a minimum of 18 inches wide to provide sufficient distance from the tree trunk at the time of planting. Tree guards are an opportunity to provide a special design and to incorporate artistic elements.

**Edging and planting guards:** Tree basins may be edged with low planting guards where sidewalks have appropriate clearances per Section 4.2. Edging treatments are appropriate for residential and commercial neighborhoods with moderate to low pedestrian traffic. Where used, the base of the guards must be a solid 4 inches to allow for cane detection. See DPW's Sidewalk Landscape Guidelines.

Planting guards may be constructed of wood or metal. Ornamental iron edging may be acceptable if it does not present any sharp edges that would pose a safety risk for pedestrians.

Edging the tree basin with a contrasting material such as cobbles or brick paving may be used as a design treatment.

Edging should not prevent water from moving off of the sidewalk and into the tree basin, and should be designed to allow rainwater from the sidewalk (in all cases) and/or the street (if specifically designed to do so) to flow into the planted area. Openings in the edge treatment can allow for water to pass through.

Where the base of landscaping is not at grade with the surrounding sidewalk, such as on sloped streets where planting is terraced and in stormwater infiltration planting areas, a 4 to 6 inch raised edging treatment should be installed around the landscaped area to delineate the presence of landscaping and grade change to people with visual impairments.

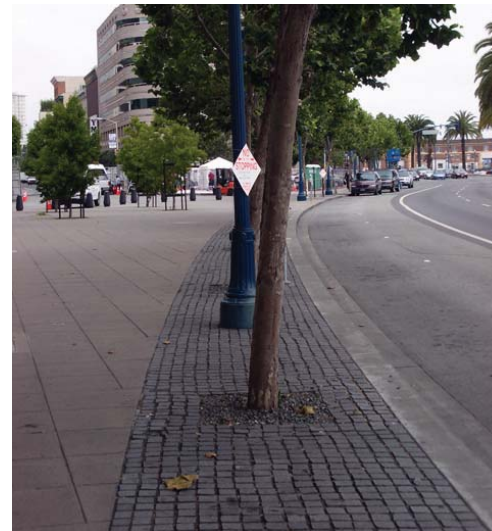

▲ Tree grates present an aesthetic urban design treatment; however, they may present difficulties for maintenance and tree health

## MAINTENANCE

### Pruning

- Pruning should be conducted under the supervision of a certified arborist. All tree maintenance work shall comply with Pruning Standards for Public Trees in the City & County of San Francisco, available from the DPW Bureau of Urban Forestry.
- On the pedestrian side of the sidewalk or median, the lowest branch that extends over the path of travel should provide an 80 inch minimum vertical clearance.
- On the vehicular traffic side of the sidewalk or median, the lowest branch should provide a 14 foot minimum clearance where branches extend beyond the curb or driveway.
- Newly planted trees should not have branches that extend beyond the perimeter of the tree basin or median below the 80 inch minimum vertical clearance.

- Tree foliage should be maintained to provide a minimum 6 foot clearance from any public street-light. Trees should not obscure traffic or parking signs, signals, or vehicular sightlines.
- Pruning may not result in topping trees; situations where tree canopies will require topping below light standards or utilities must be avoided. Trees with taller canopies should be used at a height above the street light or trees should be spaced so as to spread out between light standards.
- Trees should be pruned for 1 to 2 feet of clearance to building façade and building signage.
- Proper pruning and maintenance of trees should allow trees to develop healthily and retain their natural form.

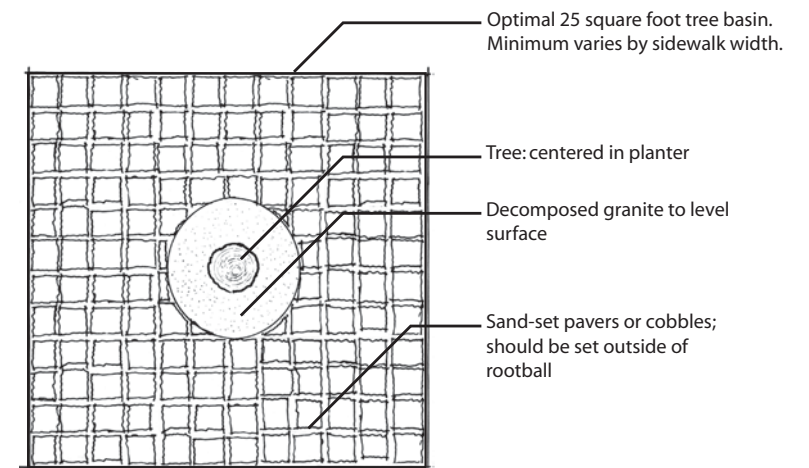

## Understory Landscaping

Understory landscaping includes sidewalk planting strips and landscaping in tree basins, adding green space to sidewalks. They are most appropriate where frequent pedestrian traffic between parked cars and the sidewalk is not expected or where a pedestrian path can be provided for people moving between the sidewalk and parked cars. This simple and inexpensive addition to the streetscape adds aesthetic, habitat, and ecological value to the city's right-of-way.

Understory landscaping:

- reduces impervious area and surface runoff;
- naturally treats stormwater improving water quality;
- provides infiltration and groundwater recharge;
- provides habitat;
- adds aesthetic value and promotes community stewardship; and
- provides a buffer between the active pedestrian area of sidewalks and the street, enhancing pedestrian comfort.

### → PLACEMENT

Planting strips and sidewalk landscaping are suitable for many street types, including residential, commercial, mixed-use, and special streets. Planting strips can be located in sidewalks, parking lane planters, curb extensions, and medians.

More formal sidewalk buffer planting is generally appropriate for downtown, commercial, and special streets, whereas on residential streets plantings may have a more diverse character.

Planting strips can be located in most soil types, all microclimates, and where topography limits slopes to <10%; where existing topography exceeds 10% planters can be terraced to achieve <10% slopes within each landscaped area.

▼ Tree Basins can be lined or edged in many different ways



### ↶ GUIDELINES

The following section provides guidance on creating spaces for sidewalk landscaping beyond simply adding plants to a tree basin. Community sidewalk landscaping is permitted through DPW's Sidewalk Landscape Permit.

#### Species Selection

In addition to landscaping, street trees are strongly encouraged in sidewalk planting strips if planting areas are of sufficient width (see previous section).

Most plants are acceptable for understory landscaping; however, ivy and other invasive groundcovers should be avoided as they can provide protective cover for pests. Tall, dense bushes and hedges should also be avoided as they can limit visibility and accessibility.

Understory landscaping should use drought-tolerant species. Deep rooted native or drought-tolerant species have many benefits including tolerance to flooding and drought, low or no irrigation needed once established, improving water quality by filtering pollutants, and aerating and increasing the permeability of soils. Native and drought-tolerant species provide wildlife habitat and generally contribute to the health of the soil, and should be considered wherever understory landscaping projects are implemented.

Planting strips can be designed to detain, cleanse, and infiltrate stormwater. In more significant storm events, overflow from one planter can be channeled to the next. For more information see Section 6.2: Stormwater. In most cases, a street does not require re-crowning or other significant work to direct stormwater runoff to landscaped planters.

### Location and Spacing

Planting strips should be a minimum of 3 feet wide along a street where trees are to be planted. Narrower planting strips less than 3 feet wide are not recommended but can be adequate for narrow plants and vines adjacent to buildings.

Planting strips must maintain the minimum clear sidewalk width (“throughway zone”) adjacent to the planting strip

for the street type per Section 4.2. Per ADA regulations, in no cases may this be less than 4 feet in width.

Where parking lanes are present, planting strips must provide access from the sidewalk to and from parked cars (“edge zone”), per the following:

- Planters must leave a minimum 2 foot wide edge zone from face of curb (2 1/2 feet with angled or perpendicular parking).
- A minimum 4 foot wide walkable path should be provided to each parking space. The path should be aligned with the approximate location of the center of the parked vehicle.
- The edge zone and path for parked cars should be a walkable strip using a walkable paving material.

Planting strips should not be installed in the following locations:

- adjacent to an existing designated accessible parking or passenger loading zone, except plantings that maintain 8 feet of sidewalk through width;
- immediately adjacent to an existing crosswalk or in locations that impact curb ramps; and
- within 5 feet of a fire hydrant in any direction.



### Best Practice: Sidewalk Buffer Planting

Chicago, Illinois

Sidewalk planters are commonly found throughout Chicago. On blocks with sufficient sidewalk width, planters are installed on both sides of the path of travel. A walkway is typically provided along the curbside to provide access to the parking lane and to accommodate small utility facilities and signposts.



- ▶ Planting areas should include paths to allow people to walk to and access vehicles without damaging plants

### *Planting Along the Property Line*

On streets where there is not enough sidewalk space to install sidewalk landscaping in the furnishing zone or where sidewalk width allows, planting in the frontage zone should be considered. This strategy is particularly relevant at transit stops where sidewalk landscaping otherwise can not be placed adjacent to the street edge.

Property line planting strips that do not include trees may be as narrow as 6 to 12 inches. These can be designed as cut-outs in the sidewalk for vine plantings, or can be an area used for planter boxes or other containers.

Widened property line planting strips may contain trees if buildings along the property line are set-back from the sidewalk. Dimensions for planting strips with tree basins should follow the guidance in the previous section.

Shallow-rooted landscaping such as groundcovers, grasses and small shrubs should be used to minimize the risk of root damage to building foundations if there is no building setback.

Planting along the property line may also incorporate creeping vines and other similar materials to cover a building façade. Such treatments, called living walls or rain screens, can have stormwater management value as well (See Section 6.2: Stormwater).

### *Planting in Medians and in Parking Lanes*

Understory planting should also be included in parking lane planters and medians as follows:

**Medians:** Understory planting should be included in medians greater than 4 feet in width, including curbs. Landscaping in medians is strongly encouraged wherever site conditions allow. Low maintenance, drought tolerant species are encouraged.

A 2 foot wide path clear of plantings should be provided for maintenance workers where possible. Median edge treatments, curbs, and striped areas in the roadway all may count toward this area.

**Parking lane:** Understory planting should be included in parking lane planters with the same requirements as understory planting in sidewalk tree basins. See also Section 5.6: Parking Lane Treatments.

### Design of Planters

#### *Other Streetscape Elements within Planting Strips*

Parking signs, street lights, utility poles, and other above-ground infrastructure located in planting strips should be set in concrete for adequate anchoring.

Planting strips should provide access to site furnishings including mailboxes, trash receptacles, bike racks, and other street fixtures, not including parking meters.

Points of access to underground utilities should remain accessible through the plantings, but may be set within the planting strip. Areas that align with the planting strip but

are not planted should be delineated by a sidewalk paving treatment or material that provides a visually contrasting surface, such as DG, bricks, or other walkable materials.

#### *Terraced Planters*

Planter strips should be terraced on sites with slope greater than 10% to avoid soil erosion and spillage on to the sidewalk. Landscaping and edging treatments should allow water to drain from the sidewalk into the landscaped area.

In areas with a known high water table and other subsoil issues, sites should be reviewed on a case-by-case basis as to their appropriateness for permeable landscaping. In such cases, an underdrain system should be used to drain the soil. See Section 6.2.

#### *Planter Furnishings*

See Street Trees: Tree Basin Furnishings, previous section.

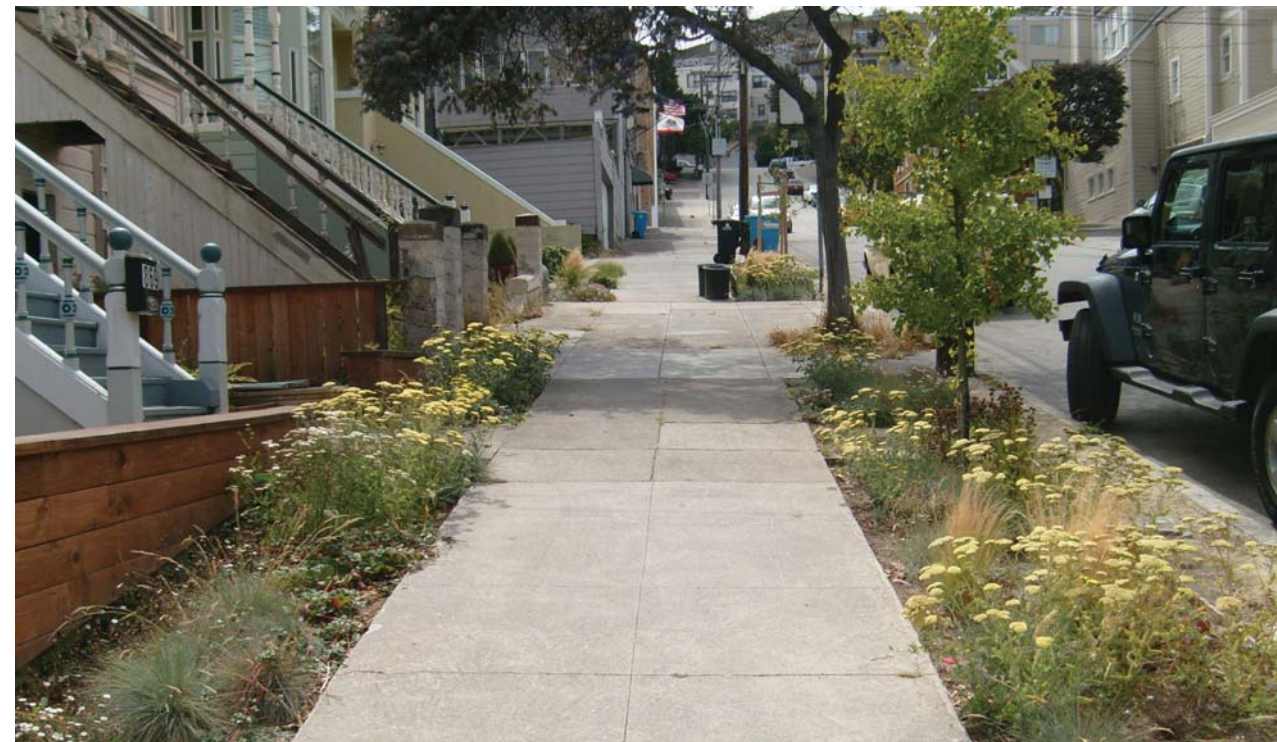

## Above-Ground Landscaping

Above-ground planters include potted planters, raised planter beds, hanging baskets, and other containerized bodies for trees and landscaping. Continuous and more substantial plantings in extended planter boxes can provide a buffer between the roadway and sidewalks, creating a more quiet and comfortable pedestrian environment. However, above-ground planters often present challenges for maintenance.

### ➔ PLACEMENT

Above ground planters are appropriate for locations where existing sidewalk space or soil conditions do not allow for planting in the ground, such as where major utilities or basements beneath the sidewalk exist.

On downtown, commercial, and mixed-use streets, above ground planters may be appropriate (or required) to delineate the edge of sidewalk seating areas or outdoor displays. Many businesses and larger developments on all street types may include planters at street level as an architectural element, especially when integrating seating into the planter edge.

Above ground planters should also be used as dividers at the edge of outdoor seating areas to provide a cane detectable edge. See Section 6.5.

Raised planters should be considered an exception rather than a rule because of increased maintenance needs and water requirements.

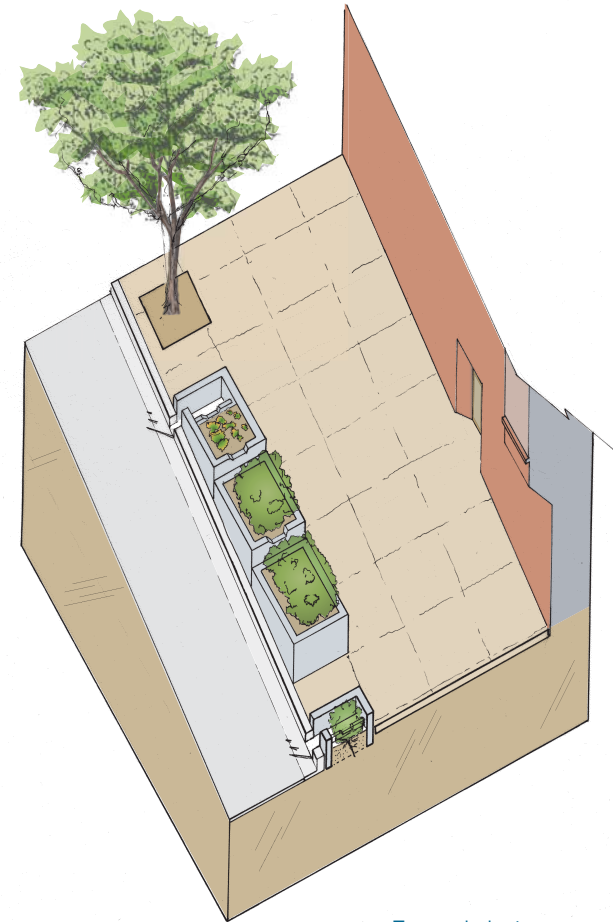

▲ Terraced planters should be used on sloping sites over 10% grade.



### ➔ Best Practice: 12th Avenue Green Street

Portland, Oregon

This project, in downtown Portland and completed in 2005, involved converting the previously underutilized landscaped area between the sidewalk path of travel and the curb into a series of planters designed to slow, capture, cleanse and allow for infiltration of stormwater runoff. The project manages the street's stormwater runoff on site instead of discharging it into the storm drain system, which feeds directly into the Willamette River, creating environmental benefits and an urban amenity.

Runoff from 8,000 square feet of the street flows downhill along the curb until it reaches the first of four planters. The runoff is channeled into the planter through a 12 inch cut in the curb. In the planter, the water infiltrates into the soil. If the water in the planter reaches capacity, it exits through another curb cut, flows back into the street and enters the second planter downstream.

The runoff continues its downhill movement from planter to planter until all are at capacity. At that point, the water exits the last planter and enters the storm-drain system. The planters are able to manage nearly all of the street's annual street runoff, estimated at 180,000 gallons.

## GUIDELINES

Above ground planters should generally be a secondary alternative to in-sidewalk plantings.

### Container planting of trees

Trees planted in containers require high maintenance, show limited growth and vigor, and are often short lived. Container planting of trees is appropriate where trees are desired and where sub-grade conditions would otherwise preclude a tree.

Container plantings should follow the same spacing requirements for street trees discussed earlier in this section. Piped irrigation should be provided. Planters should not be smaller than 16 cubic feet and should be constructed of durable materials that complement the design aesthetic of the street. Materials should be resistant to vandalism and damage from motor vehicles. Opportunities for incorporating seating into the planter are encouraged.

- ▶ Hanging baskets are generally discouraged but may be used on key corridors where a plan for maintenance exists.



### Raised planter beds

Raised planter beds can be incorporated into larger sidewalk elements such as seating areas. Planter edges may be used as seating walls. Raised planters should meet all sidewalk clearances in Section 4.2.

### Hanging baskets

Hanging baskets can be added to a number of streetscape elements to add unique urban design detail and identity to a street or neighborhood. Use of drought tolerant perennials such as succulents is highly encouraged. Because hanging baskets are maintenance and resource intensive, they are not a preferred landscaping method. However, hanging baskets might be appropriate in some instances, such as where funded by community benefit districts (CBDs) or at important civic or ceremonial locations.

### Rain Screens/Living Walls

Rain screens are plantings on the exterior walls of buildings. They are an emerging technology which can remediate water pollution and attenuate peak stormwater runoff. See the San Francisco Stormwater Design Guidelines for more information.

- ▼ Raised planting beds create opportunities to integrate seating walls





Sub-surface infrastructure and conditions have a significant impact on streetscape design. What lies beneath the surface can be both a formidable constraint and a fantastic opportunity in terms of adding landscaping, green infrastructure, and other streetscape improvements.

# Stormwater Management Tools

## 6.2

**NOTE:** More information and technical design specifications for all stormwater management tools can be found in the *San Francisco Stormwater Design Guidelines*.

Concrete, asphalt, building roofs, and parking lots all prevent rainfall from absorbing into the ground. Instead, this rainfall collects into runoff, accumulating chemicals, oil, metals, bacteria, and other by-products of urban life. Left untreated, this polluted runoff contaminates the ecosystems of the bay and the ocean. Additionally, the hardening of the city's surfaces keeps water from recharging groundwater aquifers, causing subsidence and other problems.

High quantities of runoff may also cause flooding and contribute to combined sewer discharges during large storm events. The tools presented in this section can help mitigate these environmental problems by removing or delaying the runoff stream and treating associated pollutants before stormwater is discharged into sewers and storm drains and, ultimately, to receiving water bodies such as the bay or ocean. For these reasons, wherever it is possible to do so,

water should be directed to stormwater features first, before entering catch basins. In addition to the ecological benefits that stormwater management tools can provide, these tools can be used to make the city's streets more beautiful and enjoyable places to be.

This section presents stormwater management tools, individually referred to as "stormwater facilities," that promote the advancement of Low Impact Design (LID). See sidebar, following page. These facilities have stormwater management benefits and contribute to streetscape aesthetics. The facilities are classified into broad types to help the user identify appropriate stormwater mitigation strategies for use within the range of street types.

Figure 6.4 presents the stormwater management tools described in this chapter and their typical functional benefits.

### ➔ In this section: Stormwater Tools

- Permeable Paving
- Bioretention
- Swales
- Vegetated Gutters
- Vegetated Buffer Strip
- Channels and Runnels
- Infiltration and Soakage Trench
- Infiltration Boardwalk



Choice of stormwater facilities should be based on the context of the surrounding streetscape (See Figure 6.5). These measures assume that a primary goal of the improvement is to mitigate stormwater effects; the *San Francisco Stormwater Design Guidelines* set quantifiable mitigation goals - see sidebar at right.

This section is guided by the principle that in most cases, any stormwater mitigation is favorable, and highlights the relationship between these measures and other benefits such as streetscape aesthetics, habitat, and placement.

In addition to its impact on stormwater quality and quantity, multi-purpose design of stormwater facilities can add aesthetic value to the city by providing varied landscaping, visually appealing pavement design and enhanced community spaces. They can also be combined with traffic calming features.

Stormwater tools can add health and value to the urban ecology by enhancing the linkage of existing parkways and parks for improved aesthetics and neighborhood community spaces. In addition, these localized vegetated areas can create new habitat for wildlife, particularly birds and butterflies. Finally, by reducing total stormwater flows, the use of stormwater management tools may decrease the cost to the City of pumping and treating stormwater.

FIGURE 6.4  
FUNCTIONS OF  
STORMWATER FACILITIES

	FUNCTION				Water Quality
	Detention	Retention	Infiltration	Conveyance	
Permeable Paving	○	○	○		○
Flow-Through and Infiltration Planters	○	○	○		○
Swales	○		○	○	○
Rain Gardens	○	○	○		○
Channels and Runnels				○	
Infiltration and Soakage Trench	○	○	○		○
Infiltration Boardwalks	○	○	○		

DEFINITIONS

**Best Management Practice (BMP):** Operating methods and/or structural devices used to reduce stormwater volume, peak flows, and/or pollutant concentrations of stormwater runoff through one or more of the following processes: evapo-transpiration, infiltration, detention, filtration, and biological and chemical treatment.

**Bioinfiltration:** A process that uses vegetation to capture and biologically degrade pollutants. Water is biologically treated while percolating through the system and into the existing soils, providing groundwater recharge.

**Bioretention:** A soil and plant-based retention practice that captures and biologically degrades pollutants as water infiltrates through sub-surface layers containing microbes that treat pollutants. Treated runoff is then slowly infiltrated and recharges the groundwater. These biological processes operate in all infiltration-based strategies, including the previously described retention systems.

**Conveyance:** The process of water moving from one place to another.

▼ Low-impact design (LID) prioritizes the use of small localized facilities that improve streetscape aesthetics in addition to stormwater quality.



➔ Infiltration & The Stormwater Design Guidelines

The Better Streets Plan focuses on types of criteria appropriate to the public right-of-ways, and their applicability and design considerations for placement in the right-of-ways. Technical specifications for sizing and infiltration rates of stormwater management tools can be found in the *San Francisco Stormwater Design Guidelines* (SDG) Appendix A, as well as non-right-of-way strategies for treating and managing stormwater.

Development or redevelopment projects disturbing 5,000 square feet or more of the ground surface are required to manage stormwater on-site. Land disturbing activities include, but are not limited to, clearing, grading, filling excavation, or the addition or replacement of impervious surfaces. All projects must complete a stormwater control plan, those projects served by separate stormwater sewers must achieve LEED SS6.2 and those served by the combined sewer system must achieve LEED SS6.1.

Right-of-way projects associated with new and redevelopment projects located within the separate sewer areas will be required to comply with the *San Francisco Stormwater Design Guidelines*.

▼ San Francisco's Mint Plaza is designed with stormwater management in mind to convey stormwater through channels to a bio-retention facility.



## ➔ Low Impact Design (LID)

Low-Impact Design (LID) refers to stormwater management that prioritizes the use of distributed control facilities that are typically landscape-based tools to not only reduce stormwater pollution and volume on-site, but also to provide ancillary benefits of improved greenery, place-making, and other aesthetic and quality of life related improvements. LID is also referred to as Low-Impact Development, Green Stormwater Management, and a number of other terms; however, San Francisco has elected to use the term LID to highlight the role of stormwater management as an important part of good public space and building design.



**Design storm (Minor storm):** For separate sewer areas of San Francisco, the design storm is 0.75 inches of rainfall, which is the performance measure for semi-arid watersheds from the LEED Sustainable Sites Credit 6.2 titled “Stormwater Design: Quality Control.” For combined sewer areas, the goal is to manage 25% of the 2-year 24-hour storm, equivalent to LEED Sustainable Sites Credit 6.1 titled “Stormwater Design: Quantity Control.”

**Detention:** Stormwater runoff that is collected at one rate and then released at a lower rate. The difference is held in temporary storage.

**Filtration:** A treatment process that allows for removal of solid (particulate) matter from water by means of porous media such as sand, soil, or a man-made filter. Filtration is used to remove contaminants.

**Infiltration:** The process by which water penetrates into soil from the ground surface.

**Low Impact Design (LID):** An innovative stormwater management approach with a basic principle that is modeled after nature: manage rainfall at the source using decentralized facilities.

**Major storm event:** A rainfall event that is larger than the design storm. Although treatment facilities are not designed specifically to treat all the runoff from major storm events in the same capacity as a minor storm event, they should be designed to allow for the conveyance of larger flows without causing on-site flooding or erosion.

**Peak flow:** The point during a rainstorm where there is the highest volume of runoff in the city’s drainage system. Peak flow can be considered as the runoff ‘peak’ on a hydrograph.

**Permeability/Impermeability:** The quality of a soil or material that enables water or air to move through it, and thereby determines its suitability for infiltration-based stormwater strategies.

**Retention:** The reduction in total runoff that results when stormwater is diverted and allowed to infiltrate into the ground through existing or engineered soil systems.

**Runoff:** Water from rainfall that flows over the land surface that is not absorbed into the ground.

**Sedimentation:** The deposition and/or settling of particles suspended in water as a result of the slowing of the water.

## ➔ PLACEMENT

The stormwater management tools mentioned in this manual are highly customizable and can be integrated into a variety of different types of spaces in any of the street types. Opportunity sites include: corner and mid-block curb extensions, medians, pork chops, traffic circles and roundabouts, parking lane and sidewalk planters, streetscape plazas, roadway and park edges, the front building edge, street trees, and stand alone raised planters. They may be placed in the roadway on alleys with DPW approval.

Stormwater can also be used within landscaping or educational and art features. Designers of these facilities should look for opportunities to combine artistic elements, public art, and educational opportunities with stormwater management.

The following sections describe opportunities to place, construct, and retrofit systems to include stormwater management tools into both new and existing streets. Figure 6.5 describes typical applicability of specific stormwater tools to individual street types.

**FIGURE 6.5**  
**BEST FIT FOR**  
**STORMWATER**  
**FACILITIES BY**  
**STREET TYPE**

STREET TYPE		PAVING	BIORETENTION			CONVEYANCE		OTHER		
		Permeable Paving*	Rain Garden	Flow through and infiltration planter	Infiltration Boardwalks	Swales	Channels and Runnels	Infiltration and Soakage Trenches	Vegetated Buffer Strip	Vegetated Gutter
COMMERCIAL	Downtown Commercial	○	○				○	○		
	Commercial Throughway	○	○	○	○		○	○		
	Neighborhood Commercial	○	○	○	○		○	○		
RESIDENTIAL	Downtown Residential	○	○	○		○	○	○		○
	Residential Throughway	○	○	○		○	○	○		○
	Neighborhood Residential	○	○	○		○	○	○		○
INDUSTRIAL AND MIXED-USE	Industrial	○	○	○		○	○	○		
	Mixed-Use	○	○	○	○		○	○		
SPECIAL	Parkway	○	○	○		○	○	○	○	○
	Park Edge	○	○	○		○	○	○	○	○
	Multi-Way Boulevard	○	○	○		○	○	○	○	○
	Ceremonial (Civic)	○					○	○		
SMALL	Alley	○	○	○			○	○		
	Shared Public Way	○	○	○			○	○		
	Paseo	○	○	○	○		○	○		



**FIGURE 6.6**  
**STORMWATER**  
**FACILITIES BY**  
**LOCATION IN**  
**THE RIGHT-OF-WAY**

PLACEMENT	PAVING	BIORETENTION			CONVEYANCE		OTHER		
	Permeable Paving*	Rain Garden	Flow through and infiltration planter	Infiltration Boardwalks	Swales	Channels and Runnels	Infiltration and Soakage Trenches	Vegetated Buffer Strip	Vegetated Gutter
Private Driveway or Yards	○	○	○	○	○	○ (covered)	○		
Sidewalk	○	○	○	○	○	○	○		
Curb Extension	○	○	○	○	○	○	○		
Parking Lane/Gutter	○	○	○		○	○ (covered)	○		○**
Bike Lane									
Through Lane									
Median	○	○*	○		○*	○	○*	○	
Traffic Circles	○	○*	○	○	○*	○*	○*		

\*Site conditions such as street grading may require special engineering; comply with DPW Director's Order on Permeable Paving

\*\* Best used in locations with few driveways or curb cuts



▲ Stormwater management tools are highly customizable and can be designed in ways that are appropriate to a wide variety of contexts



- Areas not in the combined sewer system
- Port areas possibly not in the combined sewer system
- Port areas most likely not in the combined sewer system

- ▲ San Francisco's topography and geology limit the applicability of some tools in certain areas of the City, and in all cases define the applicability of some infiltration-based tools, size and design elements critical to a successful stormwater management tool. In combined sewer areas, water quantity is the primary concern; in separate sewer areas, water quality is the primary concern.

## GUIDELINES

When integrating a stormwater treatment into a new or existing streetscape, designers should consider the objective of the installation. Where streetscape conditions allow, stormwater measures can be designed for conveyance, detention (peak rate control), retention (volume reduction), infiltration (groundwater recharge), and nutrient and sediment removal. (See Figure 6.4)

### Site Constraints

Streetscape geometry, topography, and climate determine the types of controls that can be implemented. The initial step in selecting a stormwater tool is determining the available open space and constraints. Although the size of a selected stormwater facility is typically controlled by the available area of opportunity, the standard design storm should be used to determine the appropriate size, slope, and materials of each facility.

After identifying the appropriate stormwater facilities for a site, an integrated approach using several stormwater tools is encouraged. To increase water quality and functional hydrologic benefits, several stormwater management tools can be used in succession—called a treatment train approach. The control measures should be designed using available topography to take advantage of gravity for conveyance to and/or through each facility. Concentrating too much runoff in one area should be avoided.

### Infiltration Considerations

Appropriate soils, infiltration media, and infiltration rates should be used for bioinfiltration and infiltration. A complete geotechnical report should be undertaken to determine infiltration rates, soil toxicity and stability, and other factors that will affect the ability and the desirability of infiltration.

Stormwater tools can be incorporated into areas of low permeability or where infiltration of stormwater is not desirable if special measures are undertaken. Underdrains should be used in areas where ponding is a concern. The location of the underdrain is an important consideration: if placed higher in a facility, the stored water below the perforated pipe will be infiltrated; if placed at the bottom of a sealed system, the perforated pipe will release the stored water slowly over time. All BMPs must have an approved overflow location for discharge. Approved locations are catch basins and outfalls.

Minor details can translate into the ultimate success or failure of a system. For example, poor soils may cause conditions in which plants will not survive or stormwater runoff ponds or infiltrates too fast. Over-compaction or smearing of subsurface soil during excavation can lead to reduced infiltration capacity and flooding. The bottom surface of infiltration areas should be level to allow even distribution and good permeability.

Catch basins may also be designed with water quality filters, catch basin hoods and litter guards to help enhance the treatment of rainfall runoff.



*Left:* Multi-purpose design of stormwater management tools stresses creating stormwater infrastructure that also improves public space.  
*Source:* EPA Office of Water

*Right:* Stormwater management can be a component of many other strategies elaborated in this plan, including remediating pork chop triangles.  
*Source:* Kevin Perry

## Landscaping

Landscaping should be chosen to fit the specific type of stormwater facility and should be appropriate for the local climate and soils. In general, all landscape-based stormwater facilities should be planted with drought-resistant and water-tolerant plantings that can survive periodic drought and inundation. Native, deep-rooted plantings or Mediterranean plants have been proven most effective. See the San Francisco Stormwater Design Guidelines Vegetation Palette for planting ideas.

Landscape features in stormwater facilities should follow the placement and clearance guidelines for understory plantings. See Section 6.1.

## Streetscape Considerations

### Utilities

Subsurface utility locations and building laterals should be factored into design considerations - access to utilities should be maintained. The presence of multiple driveways may also limit the ability to provide stormwater facilities. Where a high number of driveways or utilities reduces the ability to implement stormwater management tools on sidewalks, median locations for stormwater facilities should be considered.

### Accessibility

Standard requirements for sidewalk accessibility and clearances apply to planting areas and other stormwater facilities incorporated into the sidewalk. Specifically, stormwater facilities should follow these guidelines:

- Stormwater facilities that incorporate open planters, channels, or ditches should not be located in the through path of travel, at corners, or anywhere along the required accessible path
- Where stormwater facilities cross the path of travel, they should be covered by an ADA-compliant cover.
- Permeable paving systems in the path of travel should have no more than 1/4 inch gap between pavers

### How Do Permeable Paving Systems Work?

- Pavers allow the surface to eliminate direct runoff by absorbing rainfall, letting water seep through the hard surface
- Water is temporarily stored in the subsurface volume of an aggregate layer that supports the pavement surface
- Water leaves the aggregate by either percolating into the ground (retention and infiltration) or by being drawn away through an underdrain if the subsoils are too saturated or impervious (detention).

- Where there is a vertical drop between sidewalks and stormwater facilities (such as bioretention facilities or channels), a 4 inch high lip should be provided at the edge of the facility for tactile detection.

### Transit Stops

Certain stormwater facilities, such as those that use open planters or channels, are not appropriate within transit stops, except in limited locations. However, this does not mean that there is no possibility for stormwater treatment at transit stops.

Appropriate strategies near transit stops include: building-adjacent planters, covered channels or runnels, and permeable paving. Any drainage feature within a transit waiting area should be covered by an ADA-compliant culvert, boardwalk, metal grate, or similar feature.

All strategies used should maintain a clear path of travel to shelters and boarding transit vehicles, per Section 5.5: Transit-Supportive Streetscape Design.

## Permeable Paving

Permeable paving, also called pervious paving, is an alternative to standard paving and can help reduce stormwater runoff volumes by reducing impervious surface and providing temporary storage and or groundwater recharge through infiltration. Absorbed water is temporarily stored in the rock base before being discharged through subdrains or infiltrating into the soil. Permeable paving can thereby decrease the cost of required on-site detention systems and downstream stormwater infrastructure upgrades due to the potential for stormwater runoff delay and volume reduction.

Permeable paving has also been shown to improve water quality by trapping pollutants such as sediments and oils within the underlying rock materials and by reducing the temperature of stormwater runoff before discharge to downstream systems. By draining water, they may also reduce puddling and slip hazards.

Permeable paving systems are typically surface paving systems that convey stormwater to an underlying uniformly graded aggregate base, where it is temporarily stored for either infiltration into subsoils or slow release to a storm drain system. Permeable paving surfaces can be divided into two general categories based on application:

- Common pervious pavement surfaces typically laid on open-graded angular drain rock include: permeable unit paver block systems with joint gaps, pervious asphalt, and pervious concrete.
- For light-weight limited use areas, such as plazas or emergency access roadways, pervious pavement surfaces typically laid on non-compacted soil include: plastic systems planted with grass, and stone or pre-cast concrete blocks backfilled with gravel or sand.

### PLACEMENT

Permeable paving systems are most appropriate for pedestrian-only and low speed and vehicular traffic volume areas with minimal pollutant spill potential, groundwater contamination, or dust and debris accumulation (which will impair infiltration capacity). Permeable paving is well-

suiting to seating and walking areas within the right-of-way, including the furnishings zone of most sidewalks, curb extensions, pocket parks, and the like. See Section 6.4: Paving, for appropriate locations for special paving.

Permeable paving may also be appropriate to parking lanes that are not also travel lanes or bus stops, and low-traffic and low-speed roadways, such as shared public ways, alleys, and non-arterial streets.

Although most permeable paving systems are at least as durable as typical concrete and asphalt, they are not suitable for high speed traffic or where heavy trucks are anticipated, on steep streets, or in contaminated areas. Particularly, use of permeable paving should be avoided:

- on traffic lanes on streets classified as arterials or collectors, concrete bus pads, or curbs
- On sloped areas or steep hillsides with slopes greater than 20%;
- in areas with a previous history of soil or shallow groundwater contamination;
- in gas stations, car washes, and automotive repair shops, or in areas where there is a possibility of chemical spills;
- on streets with a history of combined sewer overflows unless as part of a project aimed at eliminating such overflows;
- in areas with shallow groundwater or seasonal high groundwater (less than 10 feet) if receiving run-on (stormwater runoff from adjacent areas);
- within 20 feet of subsidewalk basements if receiving runoff; or
- within 50 feet of domestic water wells if receiving runoff.

See also the *Stormwater Design Guidelines* for contributing thresholds and the DPW *Director's Order #178,493 on Permeable Paving Systems*.

## GUIDELINES

### Design and Location

To minimize potential for failure or clogging, design of permeable paving systems should consider:

- suitability of the selected paving material for the site conditions;
- strength of underlying subgrade - subgrade should be constructed to support anticipated vehicular and pedestrian loads for the site;
- required depth and storage capacity of base course;
- surface and subsurface materials including filter fabrics; and
- installation method.

Permeable paving requires an understanding of the prior use of a site. Site tests should be performed to determine soil conditions including: percolation rate and infiltration capabilities, depth to seasonal high water table, depth to bedrock, and soil contamination.



Existing subgrade should be able to demonstrate a minimum permeability rate of 0.5 inches per hour. An underdrain may be used in soils with lower infiltration rate in order to obtain the minimum permeability rate. Percolation testing to identify the infiltration rate of the native soil will determine the depth of base rock for the storage of stormwater, and whether an underdrain system is necessary.

A separation of 4 feet above both the high water table and bedrock is required for proper performance. Permeable paving should not be installed over new or existing compacted fill.

Selected paving materials must be ADA-compliant, and not cause tripping hazards or excessive vibration. As with all paving materials, permeable unit pavers should leave gaps of no more than 1/4" inch wide, or up to 1/2" wide with beveled edges. Beveled edges should only be used to mitigate vertical change. Vertical changes should not exceed a slope of 1:2.

- ▼ *Left:* Some permeable systems allow stormwater to flow between pavers, as shown above. Others provide a solid surface without gaps, nearly indiscernible from traditional materials.

*Right:* Permeable pavers can be used in many areas of the streetscape, and add attractive variety to typical paving.  
Source: EPA Office of Water





Both permeable pavers and porous concrete have the added benefit of elimination of polycyclic aromatic hydrocarbons (PAHs) from the wastewater stream. Where porous asphalt is used, PAH-free asphalt alternatives should be considered as a source-control measure.

### Installation

Pervious pavement is most susceptible to failure during construction. Special staging and installation phasing measures should be taken to prevent compaction, sealing, or sediment build-up, including:

- Incorporate appropriate sediment reduction techniques wherever possible. Maintain erosion and sediment control measures until a site is stabilized.
- Remove all compacted sub-base and avoid compacting soils during construction
- Spread the infiltration over the largest area feasible. Avoid concentrating too much street runoff in one area. Most types of permeable pavement can receive run-on from adjacent areas: permeable asphalt and concrete should be at least 33 percent of the total drainage area, while permeable pavers should be at least 66 percent of the total drainage area
- Avoid smearing of underlying soil, to minimize sealing of soils.
- Avoid contamination with sediment; avoid tracking sediment onto pavement.
- Avoid drainage of sediment laden waters onto pervious surface or into stone sub-base constructed bed.
- Do not allow construction staging, soil/mulch storage, etc. on unprotected pavement surfaces.

The bottom sub-grade should be graded level to allow even distribution of infiltration where soil conditions provide for permeability. Where provided, under-drains should be placed at the pavement edge to provide drainage that prevents pond formation in the base.

Any currently paved area can be retrofit with a permeable system; the existing compacted or otherwise impermeable subbase should be fully removed to prepare the soil for infiltration.

### MAINTENANCE

With proper maintenance, permeable paving materials have a proven durability of up to 30 or more years: an increased lifespan over asphalt. All permeable surfaces require routine street sweeping using vacuum sweepers every 6 months, tested annually for proper function, and have a scheduled vacuum removal of gap pea-stones and joint re-filling every 5 to 10 years.

#### Pervious Paver Systems

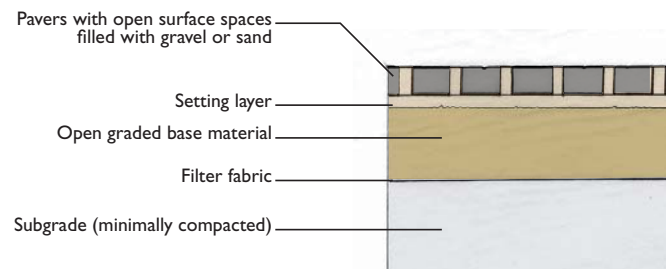

#### Pervious (Open Graded) Pavement and Asphalt Systems

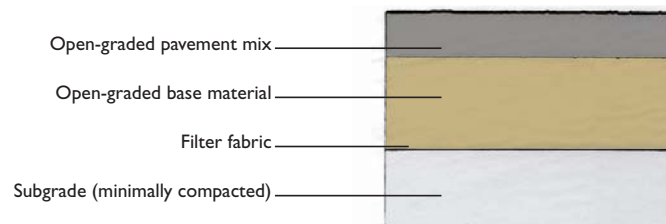

Permeable paving can be used in driveways to help address stormwater and contribute to streetscape aesthetics with unique textures and materials

Alleys, shared public ways, and other low traffic volume streets are an appropriate application of permeable paving systems



Permeable paving is also appropriate in the parking lane  
Source: EPA Office of Water



## Bioretention

Bioretention facilities combine stormwater runoff control and treatment with aesthetic landscaping and architectural detail. These landscaped areas are used to collect, filter, and infiltrate runoff from roofs, streets, and sidewalks and are designed to incorporate many of the pollutant removal and infiltration functions that operate in natural ecosystems. This is achieved by filtering pollutants through soil particles (which trap pollutants) and vegetation (which take up pollutants) as the water percolates through the system. In addition to providing pollution reduction, bioretention facilities can be used to manage runoff flow rates and volumes, thus reducing the downstream potential for combined sewer overflows.

Bioretention systems can be designed as infiltration-based systems if the native soils beneath the facility are sufficiently permeable and there are no other constraints to infiltration such as soil or groundwater contamination. If infiltration is not feasible, they can be designed as flow-through systems that are contained within an impermeable liner and use an underdrain to direct treated runoff back to the collection system.

A note on terminology: bioretention facilities that are installed directly in the ground are typically called “rain

gardens”; those that are contained within a curb or hard-walled container are typically called “planters”

### ➔ PLACEMENT

Bioretention facilities can be integrated into all street types and may be placed in frontage or furnishings zones. They may be implemented in a variety of streetscape configurations including sidewalks, curb extensions, medians, pork chops, traffic circles and roundabouts, parking lane planters, and other geometries that create space for landscaping. They can be used to capture rooftop runoff from disconnected downspouts. Because they can be effective even in small installations, bioretention systems are appropriate in constrained locations where other stormwater facilities are not possible.

Infiltration-based bioretention facilities should only be considered in areas where native soils have a minimum permeability rate of 0.5 inches per hour and where the high water table and bedrock are at least 4 feet below the bottom of the facility. Flow-through systems with an underdrain may be used in soils with lower infiltration rates. These are particularly valuable as receiving bodies for roof runoff from downspouts when placed adjacent to buildings, because they include a waterproof lining which allows them to be incorporated into foundation walls. They may also be placed in the furnishings zone to receive runoff from the sidewalk and street (through curb breaks).

Infiltration-based bioretention facilities are best suited to sites that have less than a 5% slope. For slopes greater than 5%, they can incorporate check dams or other flow control devices to retard flow. Terraced flow-through planters can

be used on a variety of slopes.

### 🔍 GUIDELINES

Minimum planter width should be 2 to 3 feet to accommodate underdrain systems, allow for planting room, and allow for constructability. Bioretention systems should follow the landscaping clearances and guidelines for understory plantings in Section 6.1.

The use of several small facilities, rather than one large facility is preferable, as it provides a distributed infiltration area. The recommended ratio of impervious area to infiltration area is 5:1, depending on soil conditions.

The depressed area should contain a surface layer of organic mulch, underlain by an amended soil plant bed that supports virtually any combination of flood-tolerant turf, grasses, shrubs, and trees. Deep rooted water tolerant plantings are encouraged to improve filtration and nutrient control benefits.

Bioretention features should be designed to drain stormwater within 48 hours after a rain event to avoid concerns about mosquitoes. Ponding depths should be limited to 6 inches or less for aesthetics, safety, and rapid draw down within that time frame. Certain situations may allow deeper ponding depths up to 9 inches, depending on location. Ponding depths increase during larger storms until runoff overflows an elevated weir or drain outlet for discharge to the city storm network. An overflow riser with a domed grate should be included for larger storm events.

Pre-treatment measures can help reduce the maintenance requirements of bioretention facilities and clogging of soils over time. Some pretreatment measures include: swales to filter out coarse sediments and debris or a pea gravel



◀ Stormwater planters can be part of the building frontage zone, where roof runoff is temporarily detained, and used as an amenity to add greenery to the streetscape

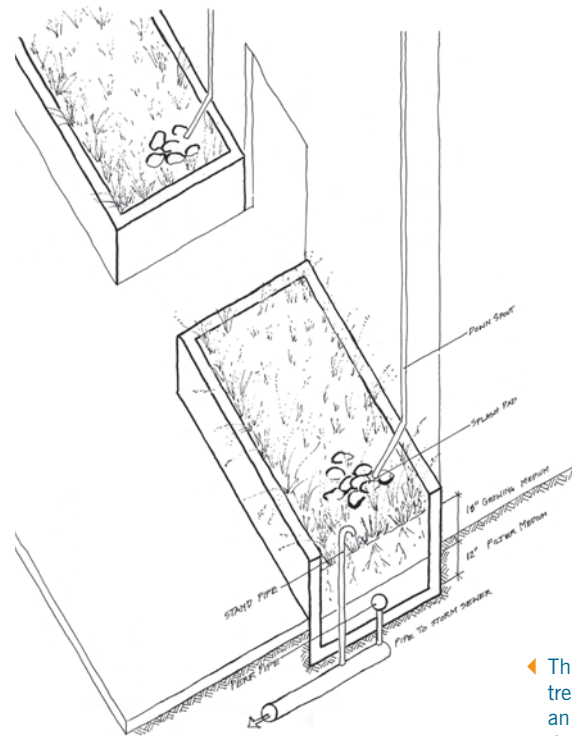

▶ This flow-through planter is designed to accept and treat roof runoff from the downspout, and includes an underdrain and an overflow pipe to ensure water does not compromise the building's structure.

border which acts to spread flow evenly and drop out larger particles.

An underdrain system should be considered where subsoil infiltration rates less than 0.5 inches/hour. A gravel trench with underdrain should be used to encourage drainage between rain events. If the system allows infiltration, it should be placed a minimum of 10 feet downgradient of 100 feet upgradient of building foundations. In some cases (outlined in the San Francisco Stormwater Design Guidelines), these distances may be reduced with SFPUC approval.

### Roadway-adjacent planters

Roadway runoff should be directed into bioretention features

by installing flush ribbon curbs on the street edge or small evenly-spaced curb cuts into the existing curb.

### Building-adjacent planters

Wherever building-adjacent planters are present, roof drains should direct water to these features first. Both underdrains and surface overflow drains are typically installed with building-adjacent planters. Building-adjacent planters should be designed to pond water for less than 48 hours after each storm.

Flow-through planters designed to detain roof runoff can be integrated into a building's foundation walls, and may be either raised or at grade. When raised, planters should be designed with 14 to 16 inch vertical heights to incorporate a seat wall.

Planters may be placed on either side of the property line to allow larger planting bodies to receive roof runoff. Planters should be structurally separate from the adjacent sidewalk to allow for future maintenance without disturbing the sidewalk. An expansion joint satisfies this requirement.

▶ Rain gardens can be part of medians, curb extensions, parks, plazas, and even typical streets. Source: Kevin Perry

▶ Rain gardens are highly customizable, and can be designed to fit into any number of spaces within the streetscape. This raingarden includes a channel, behind the pedestrian, to convey roadway runoff to the landscaped treatment area. Source: Kevin Perry

▶ Rain gardens may be placed in curb extensions on most street types



## Swales

Street swales are long narrow landscaped depressions primarily used to collect and convey stormwater and improve water quality. They remove sediment and reduce nutrient concentrations within runoff through natural treatment prior to discharge into another stormwater management facility or the sewer network. In addition to providing pollution reduction, swales also reduce runoff volumes and peak flow rates by detaining stormwater. Swales add significant landscaping to street corridors and reduce impervious surface. In some circumstances, rainwater infiltrates into the ground while being conveyed along the length of a swale.

Several forms of swales exist and are highly customizable. Natural swales are depressed linear features that combine appropriate plantings with amended soils. Bioinfiltration swales (or bioretention swales) typically include a subsurface infiltration trench below amended soil.

### PLACEMENT

Swales are suitable for many street types with long, unconstrained areas, such as within medians or the outside edge of a street. Swales can be located in the furnishings zone of streets with unbroken curb edges, such as streets without parking lanes or many driveways. Frequent driveway curb cuts and sub-surface utilities may minimize the appropriateness of installing a swale.

Swales can be connected with other stormwater facilities such as rain gardens to provide pre-treatment. Similarly, on parkways and other streets with adjacent open space, natural swales are an excellent form of treatment and runoff delay prior to directing runoff to a larger stormwater management facility or the city sewer network.

Swales are appropriate for virtually all soil types, but proper routing and design require a full understanding of local soil topography and climatic conditions.

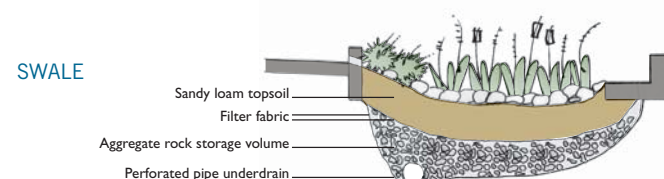

### GUIDELINES

#### Design

The preferred width for swales is 5 to 11 feet. Swales as narrow as 3 feet may be appropriate.

Swales should have shallow side slopes and depth to avoid safety risks and prevent erosion.

For swale slopes over 6%, check dams should be provided. Check dams should be constructed of durable, non-toxic materials such as rock, brick, concrete, or soil by integrating them into the grading of the swale.

Swales may be incorporated into the urban setting by incorporating hard vertical edges to create a formal edge or raised safety border.

Flush ribbon curbs on the street edge of a swale or evenly spaced small curb cuts into the existing raised curb should be used to allow roadway runoff to enter swales.

Amended topsoil should be installed to increase filtration and to improve infiltration and retention of runoff. With appropriately amended soils, a vegetated conveyance swale

▼ Swales can be used as landscape buffer  
Source: EPA Office of Water



can be combined with a subsurface infiltration trench. Where good infiltration rates exist, swales should be used in conjunction with subsurface infiltration trenches to further reduce both runoff volumes and peak discharge rates. In locations where there is low soil permeability, an underdrain should be considered.

Where swales are installed in medians, the adjacent roadway should be graded and crowned to drain toward the median swale to maximize runoff capture.

#### Landscaping

Filtration benefits of swales can be substantially improved by planting deep-rooted grasses and forbs and by minimizing the side slope.

Appropriately selected vegetation can improve infiltration functions, protect the swale from rain and wind erosion and enhance overall aesthetics. Selected species should not require irrigation after establishment.

Swales should follow landscaping clearances and guidelines for understory plantings. See Section 6.1.

▼ This parking lot swale at Sunset Circle on Lake Merced accepts and treats runoff from the parking lot



## Vegetated Gutters

Vegetated gutters, also known as green gutters, are narrow landscape systems along street frontages that capture and slow stormwater flow. Typically less than three feet wide, green gutters most resemble planters in that they are confined by vertical curbs and have a flat-bottom profile. Unlike typical planters, however, green gutters are designed to be very shallow with little or no water retention. While infiltration of stormwater is a possibility, the primary purpose of using green gutters is to provide a site design measure using strip of landscaping to help filter out pollutants and slow the flow of water. Vegetated gutters can be an inexpensive way to add greening and stormwater treatment without moving curbs.

### ➔ PLACEMENT

Vegetated gutters are appropriate on streets with extra right-of-way width that can accommodate a narrow landscaped strip, and informal conditions such as residential or green streets.

Vegetated gutters are most appropriate to streets with no on-street parking lanes and infrequent driveways, though they may be used on other streets as well.

### 🕒 GUIDELINES

Vegetated gutters have a flat base to filter pollutants and hold stormwater runoff. Where appropriate, they can be designed to infiltrate stormwater. Because they are typically narrow in width, they must be very long to adequately filter and slow stormwater.

Vegetated gutters are typically shallow, allowing no more than 3 inches of runoff to pond at one time. Since they would have a drop-off from the sidewalk, a 4 inch lip should be provided around the feature.

Where designed on streets with on-street parking and driveways, an edge zone and pass-throughs to the sidewalk from the parking lane must be provided per Section 4.2, which would break up the continuity of the stormwater facility.

## Vegetated Buffer Strip

Vegetated buffer strips are sloping planted areas designed to treat and infiltrate sheet flow from adjacent impervious surfaces. They slope away from the impervious surface and are most often planted with grass, though other uniformly distributed plant species are also appropriate. Buffer strips function by slowing stormwater runoff and allowing sediment and other pollutants to settle and infiltrate.

### ➔ PLACEMENT

Vegetated buffer strips are well-suited to treating runoff from roads and highways, roof downspouts, small parking lots, and pervious surfaces. They are also appropriate for the “outer zone” of a stream buffer. They may be commonly used on multi-way boulevards, park edge streets, or parkways with significant medians.

### 🕒 GUIDELINES

Vegetated buffers strips should be designed as attractive features that tend to be viewed as landscape amenities rather than as stormwater infrastructure. The vegetative surface

should extend across the full width of the area being drained. The thicker and more uniform the plant cover, the greater the stormwater management benefits.

Because buffer strips cannot treat large amounts of runoff, the maximum drainage width (with the direction of flow being towards the buffer) of the contributing drainage area should be 60 feet. In general, a buffer strip should be at least 15 feet wide in the direction of flow to provide water quality treatment.

The top of the strip should be set 2 to 5 inches below the adjacent pavement or contributing drainage area, so that vegetation and sediment accumulation at the edge of the strip does not prevent runoff from entering.

Buffer strips should be sited on gentle slopes between 1 and 15%. Steeper slopes may trigger erosion during heavy rain events, thus eliminating water quality benefits.

Vegetated buffers can be situated so they serve as pre-treatment for another stormwater facility.

▼ Vegetated gutter

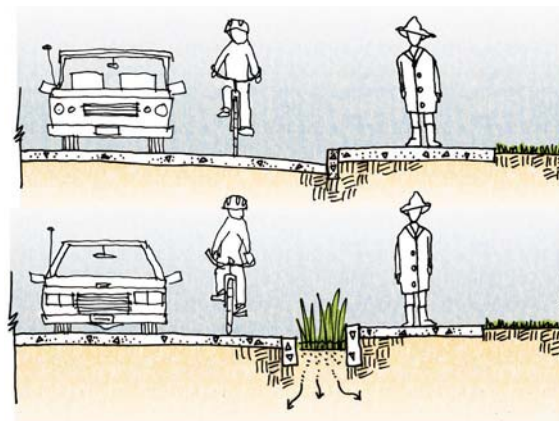

▼ Vegetated buffer strip

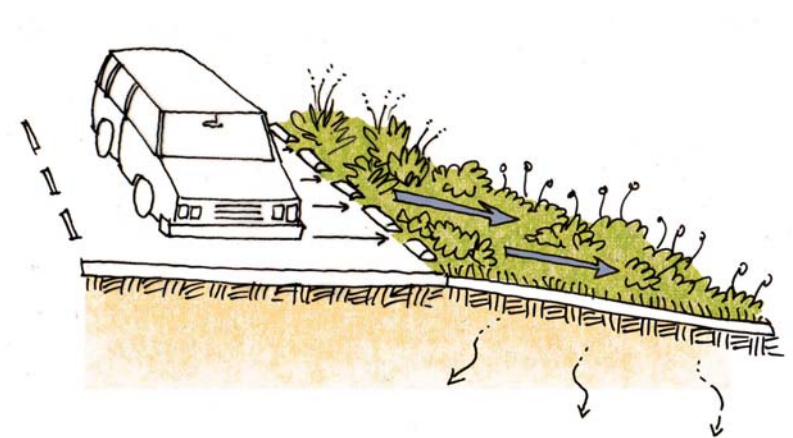

## Channels and Runnels



Channels and runnels are concrete or stone lined pathways used to convey rainwater runoff along the surface to other stormwater control measures or the city collection system. Runnels are shallow systems usually designed for small spaces and conveyance of small to moderate flows, while larger and deeper channels are used for collection and conveyance of moderate to large flows.

Channels and runnels reduce the need for buried storm drains and convey surface water where subsurface utility infrastructure prohibits the installation of additional storm drain piping. They can add aesthetic, artistic, and educational features to a design by highlighting rainfall rather than quickly directing runoff to an underground piped system.

### ➔ PLACEMENT

Channels and runnels are suitable for most street types and open spaces. They can be incorporated as an aesthetic design element along sidewalk planting areas or within central medians.

In curb extension construction, moving storm drain inlets can often be cost prohibitive. Channeling stormwater through a covered trench drain in the curb extension can allow the existing drainage infrastructure to remain, which may provide capital cost savings in some cases. See “Trench Drains” below and in Section 5.3: Curb Extensions.

### 🔧 GUIDELINES

Channels and Runnels can be designed with a wide range of materials such as unit pavers, bricks, recycled cobblestone, flat river rock, concrete, colored concrete, steel plate edging, or any durable impermeable material. They should be concrete mortared in highly urban areas for durability.

Where pedestrian crossing or accessibility is required, channels or runnels should be covered with decorative or durable linear trench drain grates, boardwalks, or other

ADA-compliant walkable surface at least 4 feet in width. The bottom of the covered channel should be maintained at or below the grade of pre-existing gutter pan to preserve drainage to the storm drain inlet.

### Runnels

Runnels are usually designed as an integrated element within street or plaza hardscapes. They should be located so as to minimize crossing of designated ADA pathways or emergency egresses. Where they do cross, a cover as described below (under Trench Drains) should be incorporated into the design.

Typical runnels range from 10 to 36 inches wide and use contrasting material for aesthetic effect and improved differentiation by people with visual impairments.

Runnels should be designed with a smooth sloping cross section with depths not exceeding 2 to 2-1/2 inches for safety. Runnels should have a gentle slope of between 0.5% and 3% toward the outlet or discharge point.

On low volume streets such as alleys, runnels can be combined with soakage trenches in the center of the roadway to drain runoff by infiltration through the roadway center. This requires grading and crowning toward the center of the street.

### Channels

Channels can also be integrated within street or plaza hardscapes for the collection of several small drainage areas. Under most circumstances, channels should have vertical hard sides with hard or natural bottom flow paths. Channels are usually deeper than 6 inches. They should be set back a minimum of 2 feet from the sidewalk or curb.

Where an uncovered change of level is present within sidewalk or plaza areas, a 4 inch raised curb or border should be incorporated into the design to provide physical separation.



▲ Channels and runnels direct water through hardscape features to other stormwater management facilities

Channels should maintain a minimum slope of at least 0.5%, and the maximum slope in the absence of structural controls should not exceed 6%. Where steeper slopes are present, terraces or check dams should be incorporated into the channel design.

### Covered Runnels or Channels (Trench Drains)

Where channels or runnels cross a pedestrian path of travel, a smooth ADA compliant cover, such as a steel grate or boardwalk, should be part of the design: this configuration is referred to as a covered channel, or trench drain. They may be used on new streets or retrofits to existing streets, at curb extensions, raised crossings, stormwater facilities, curbside streets (shared or pedestrian-only), or other places where drainage channels are necessary outside of the standard curb and gutter. This treatment may be considered as a potential cost reduction strategy in locations where curb extensions are implemented to allow pre-existing catch basin location to be maintained. They should be used anywhere a channel or runnel crosses a pedestrian path, such as within transit stops.

In many cases, trench drains may be a cost-effective and desirable solution to solve complicated drainage configurations. However, if not properly located and designed, they may present issues with drainage, maintenance, and accessibility.

#### Guidelines

Trench drains must be designed to carry the 5-year design storm event within the drain and be able to carry excess storm flow to the downstream inlet. Trench drains must maintain standard cross-slope of 2% on the sidewalk for positive drainage. In case of larger storm events or a stopped trench drain, the drainage profile of the site should be designed to drain to nearest gutter or other drainage feature, and away from adjacent properties.

Trench grates should be a minimum of 8 inches in width to allow debris to move through the drain and not severely limit the drainage capacity of the drain should debris build up.

Attractive grates should be used to provide an interesting urban design accent. They should be designed to integrate their visual appearance with the overall streetscape design.

Grates or other access panels covering trench drains through curb extensions must be designed, installed and maintained so as not to pose an obstacle or tripping hazard.

Due to the potential for increased maintenance burdens with the use of trench drains, a maintenance plan or agreement with private sponsor should be in place prior to their installation.

## Infiltration Trenches

Infiltration trenches are shallow subsurface linear stormwater facilities. They are typically 2 to 5 feet deep and installed in relatively permeable soils to provide on-site stormwater retention by collecting and recharging stormwater runoff into the ground. Trenches are typically backfilled with sand or coarse drain rock, and lined with filter fabric. The trench surface can be planted, covered with grating, covered with boardwalks, or consist of exposed drain rock or sand.

Depending upon the design, trenches allow for the partial or total infiltration of stormwater runoff into the underlying soil to reduce stormwater runoff volume. During small storm events, volume reduction may be significant and there may be little or no discharge. During large storm events, un-retained overflow should be provided by a gravity outlet.

▼ Trench drains (covered channels) can use attractive grates and can be integrated with other site design elements.

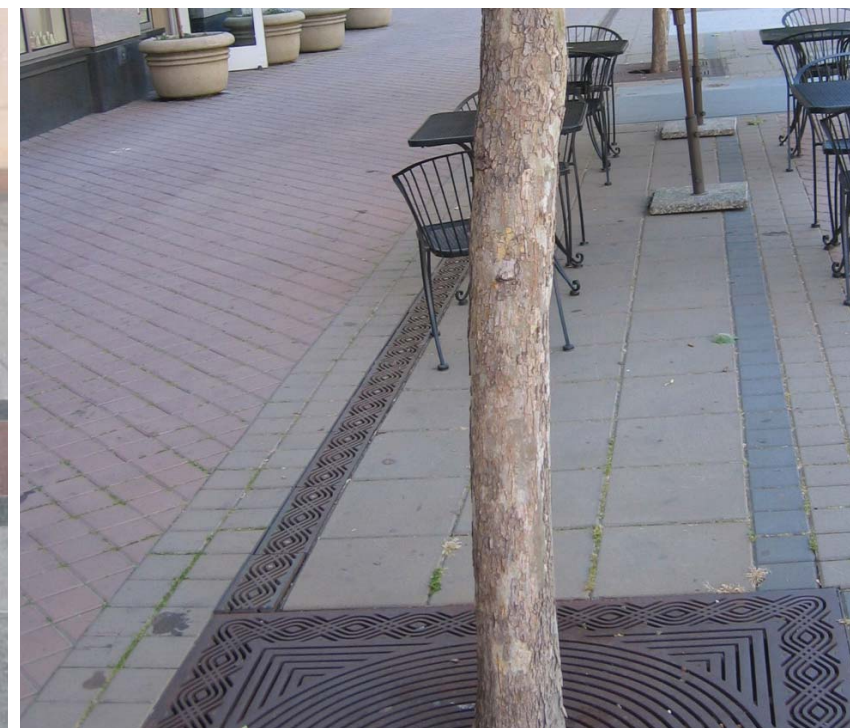



▲ This attractive architectural planter and fountain is a disconnected downspout that drains to a planter with an infiltration trench below

Infiltration trenches can be effectively integrated into most of the other stormwater facilities described in this section to enhance the function and stormwater mitigation capability of the other facility.

The selection and use of infiltration trenches is highly dependent on soil type and height of the groundwater table. Temporary storage capacity of the system can be increased by installing multiple perforated pipes into a wide infiltration bed system.

Infiltration trenches are highly customizable with relatively low maintenance and can be incorporated with other stormwater tools. They reduce runoff volumes and rates through groundwater recharge and increase water quality by filtering pollutants and sediments. Because of their narrow linear size, infiltration trenches can be installed as new or easily retrofitted into sidewalk areas or medians when not constrained by utilities.

### ➔ PLACEMENT

Infiltration trenches are typically linear systems that can be located under sidewalks or medians, within sidewalk planting strips, beneath curb extensions, and in some circumstances beneath parking lanes. Within medians, they are most effective when the street is graded and crowned to drain to the median.

Infiltration trenches should be sited on uncompacted soils with acceptable infiltration capacity. They are best used where soil and topography allow for moderate to good infiltration rates.

Infiltration trenches can be designed as a stand alone system or combined and integrated with other stormwater facilities such as swales, bioretention features, or permeable paving, or as a downstream retention system at the discharge end of most other stormwater management tools.

### ↶ GUIDELINES

Infiltration trenches should be designed to minimize potential failure or clogging. The major components to consider during design include the use of a pre-treatment water quality inlet or sediment basin, adequate system piping, non-clogging filter fabric, clean and uniform aggregate drain rock, proper trench preparation, and adequate structure design for release.

#### Pre-treatment Structure

It is critical to design for stormwater runoff pre-treatment prior to directing raw runoff into a closed infiltration trench or gallery. A pre-treatment structure is designed to receive street runoff prior to discharging to the infiltration or soakage trench to minimize the entry of sediments and other debris into the system.

A water quality inlet with a minimum 18 inch sump is recommended for all surface drain inlets prior to discharge to a surface stormwater facility or subsurface underdrain system. The inlet should be installed between the influent conveyance pipe and infiltration trench with perforated distribution pipe system. The infiltration trench should be installed a minimum of 5 to 10 feet from a building depending on whether a below grade dwelling space exists.

As an alternative, a small depressed natural sedimentation basin should be incorporated into the influent end of any stormwater facility to minimize long-term clogging.

#### System Piping

The facility piping consists of 3 parts: an inlet pipe located between the sediment basin and the infiltration trench (or downspout or area drain), a perforated dispersion pipe located in the aggregate bed of the infiltration trench, and an outlet overflow pipe.



The inlet piping should be raised such that sediments in the pre-treatment structure remain trapped and do not transfer to the infiltration system.

Within the infiltration system, a continuously perforated pipe should extend the length of the trench and have a positive flow connection designed to allow high flows to be conveyed through the infiltration trench.

Based on soil type and intended system function, adjustment to the perforated pipe elevation within the drain rock trench should be considered. For well draining soils, install the pipe near the top of the clean aggregate base to maximize infiltration. For moderate draining soils, install the pipe near the bottom of the clean aggregate base to minimize infiltration while still attenuating runoff through temporary storage.

Cleanouts or inlets should be installed at both ends of the infiltration trench and at appropriate intervals to allow access to the perforated pipe. Monitoring wells are recommended (and can be combined with clean-out). The discharge or overflow from the infiltration trench should be properly designed for anticipated flows.

### Trench

The slope of the infiltration trench bottom should be designed to be level or with a maximum slope of 1%. A level bottom assures even water distribution and infiltration. The trench and perforated pipe should be installed parallel to the contour of the finished grade. If moderate ground slope exists, the trench may be constructed as a series of steps or with clay check dams if necessary.

### Installation

Prior to design of any retention or infiltration system, proper soil investigation and percolation testing should be conducted to determine appropriate infiltration design rates. During the site layout of the facility there should be no less than 3 feet of undisturbed depth of infiltration

medium between the bottom of the facility and any impervious layer (hardpan, solid rock, etc.) or seasonal high groundwater levels (for water quality protection).

Infiltration trenches should be installed parallel to the contour with maximum ground slopes of 20% and be located no closer than 5 feet to any building structure. Compaction of soils should be avoided during construction.

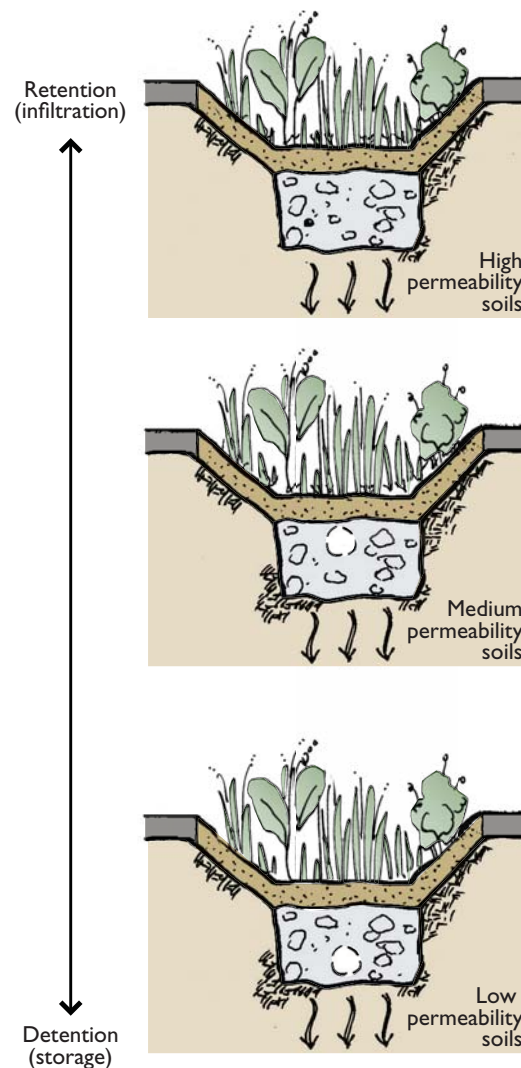

▲ Infiltration trenches can be located beneath other stormwater management tools, such as permeable paving or landscaped facilities, to increase storage capacity for infiltration



## Infiltration Boardwalks

As an alternative to exposed landscape stormwater facilities, segments of sidewalks or reconstructed curb extensions may be retrofitted with durable boardwalks to serve as clear pedestrian thoroughways integrated with stormwater management. Raised boardwalks may be placed over exposed drainage rock or amended engineered soils to allow stormwater to pass beneath a walking surface for temporary storage or infiltration into the soils below.

A boardwalk creates an exposed soil or gravel infiltration trench beneath the sidewalk that effectively reduces impervious surface area and provide opportunities to clean and infiltrate runoff from the public right-of-way, without losing valuable pedestrian space.

Boardwalks can add interesting diversity of color, texture and material to the sidewalk and create possibilities for landscaping or educational uses.

### ➔ PLACEMENT

Boardwalks are best suited for flat streets.

Infiltration boardwalks should be used in the furnishings or extension zones, outside of corners and other crossing areas. The thoroughway and frontage zones are not appropriate for this treatment.

Infiltration boardwalks are not recommended adjacent to curbs that serve as transit stops.

### 🕒 GUIDELINES

Boardwalks may continuously cover infiltration areas or sections of boardwalk can be removed and infiltration areas may be planted with rushes or grasses, resulting in a bioretention facility.

Boardwalks should be flush with existing sidewalk level and covered with an ADA-compliant walkable surface to reduce tripping hazards and maintain a sense of one continuous pedestrian realm. Boardwalks should have accessible surfaces with gaps of no more than 1/4 inch. They may use a distinct paving material from the rest of the sidewalk. (See Section 6.4.)

Similar to bioretention facilities, facilities placed in series would allow overflow from one infiltration area to be captured by the following during larger rain events, with an ultimate outflow to the nearest stormsewer system inlet.

A pre-treatment forebay should be located between each curb cut or channel entrance and the below grade infiltration system to collect street debris and allow particulates to settle out to minimize maintenance. When planting is not desired under boardwalk sections, the top surface should be designed with drain rock.

Sign poles, utility access panels, and pedestrian amenities may all be maintained within the boardwalk area with appropriate clearances (See Site Furnishings, Section 6.5).



▲ This apartment building uses boardwalks over an infiltration area to define unique entrances to each unit from a shared public way  
Source: Sherwood Design Engineers



▲ Pathways across pocket parks and other large open space areas in the right-of-way can be raised to allow infiltration below  
Source: Sherwood Design Engineers

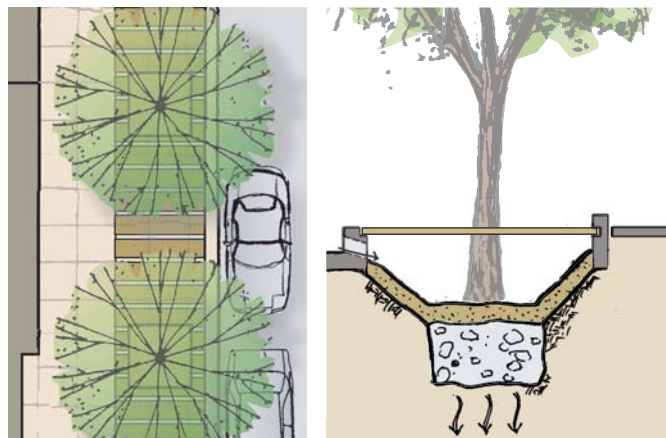

▲ *Left:* Boardwalks may be used as a sidewalk treatment in the furnishings zone, or on curb extensions.

*Right:* An infiltration trench below the boardwalk would allow roadway runoff to be detained and treated and potentially infiltrated. Infiltration basins can alternate with tree basins beneath the boardwalk to preserve street tree planting, or structural soils can be used to serve as both an infiltration and tree planting medium.

The background of the page features a dark, monochromatic image of several street lamps. The lamps are silhouetted against a slightly lighter, dark grey background, creating a rhythmic pattern of light and shadow. The lamps have a classic, rounded, lantern-like design with vertical supports. The overall mood is sophisticated and urban.

Street lighting is a key organizing streetscape element that defines the nighttime visual environment in urban settings. Street lighting includes roadway and pedestrian lighting in the public right-of-way.

# Lighting

## 6.3

Street lighting is a key organizing streetscape element that defines the nighttime visual environment in urban settings. Street lighting includes roadway and pedestrian lighting in the public right-of-way.

Quality street lighting helps define a positive urban character and supports nighttime activities. The quality of visual information is critical for both traffic safety and pedestrian safety and security. Lighting should be designed not only for vehicular traffic on the roadways, but also for pedestrians on sidewalks and pedestrian paths.

### ➔ PLACEMENT

Pedestrian lighting should be prioritized in the following locations:

- ➔ streets with high pedestrian volumes;
- ➔ key civic, downtown, and commercial streets;
- ➔ streets with concerns about pedestrian safety and security, such as at freeway underpasses; and
- ➔ small streets such as alleys and pedestrian pathways.



**GUIDELINES**

**Location and Spacing**

Street lighting poles should be located on the sidewalk close to the curb on the curb side edge, or centered within, the furnishing zone. Typically, pedestrian lighting poles align with the street lighting poles. However, on very wide sidewalks pedestrian lighting poles may be farther from the curb than the street lighting poles to light the primary walkway.

**Relation to other streetscape elements:** Pedestrian lighting should be added to street light poles where feasible unless spacing between street light poles does not support adequate pedestrian lighting, in which case pedestrian lighting may need to be located between street light poles. Light poles should be coordinated with other streetscape elements. Utility equipment above and below ground, such as pull boxes and underground trenches, should be coordinated when locating lighting fixtures.

Light fixtures should not be located next to tree canopies that may block the light. When determining tree type, anticipated height and diameter of the tree canopy should be considered relative to lighting fixture height and spacing based on light level and uniformity requirements. Appropriate distance between the tree and light fixture depends upon the type of tree and type of light fixture. If blocking the light output of the fixture cannot be avoided due to existing locations of the light fixture and trees, consider adding additional light fixtures to mitigate the shadows from the tree canopy.

**Light Distribution**

Light fixtures should be selected to efficiently direct light to the desired area of the roadway and sidewalk. Light fixtures should enable a variety of light distributions to adapt to different street and sidewalk configurations while maintaining the same fixture appearance. The distribution type should be selected based on street and sidewalk width.

Glare should be mitigated by selecting the proper lamp wattage and mounting fixtures at the appropriate height.

Sky glow is a consequence of several components of lighting: light directed to the sky from fixtures and light reflected off the ground. Light trespass is light that enters an area where it is not wanted, such as street light entering a residential property. Both sky glow and light trespass can be irritating and detrimental to the environment.

Sky glow should be mitigated by selecting dark sky friendly lighting fixtures that direct most of the light downward, by eliminating excessive light level, and turning lights off when not needed. New and replacement light fixtures should achieve a semi-cutoff light (5% or less concentration of light above a 90 degree angle from the fixture than the light output of the fixture), with a target of full-cutoff (zero light loss above the fixture or shield level). Existing fixtures should be retrofit or replaced to meet these targets as funding allows. Exceptions may be considered, such as for historical lighting or where up-lighting is desirable for security purposes.

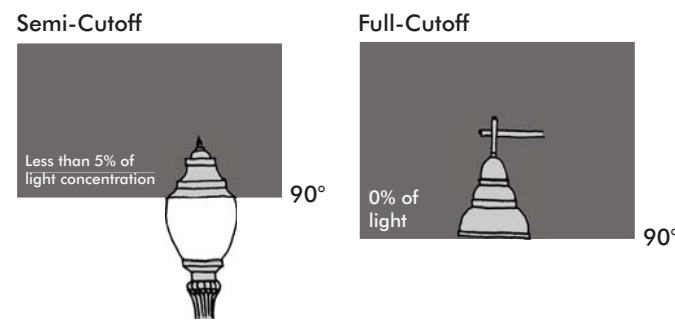

Light trespass should be mitigated by specifying the correct light distribution. Lighting fixtures should not be located close to windows to avoid light trespass or glare and disturb the adjacent building's occupants. If necessary, house-side shields may be used on fixtures to minimize light trespass into residences or other areas.

Street lighting should strive for an even distribution of light along the street

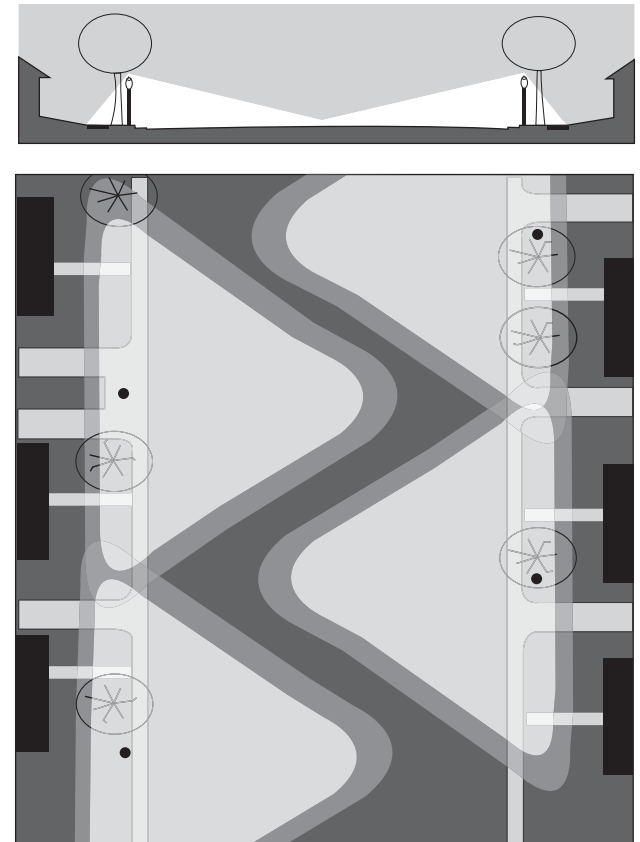

Pedestrian scale lighting fixtures better light the pedestrian way, providing an improved sense of security and comfort



### Light Color

The color of the nighttime environment is dependant upon the light source. LED (light-emitting diode), metal halide, induction, and fluorescent lamps create a relatively white light compared to the yellow of high-pressure sodium lamps. Color identification is easier and clearer under white light sources. There is also emerging data that peripheral vision is improved with white light sources.

Traditionally, high-pressure sodium lamps have been used throughout the City for their long life and energy efficiency. However, as improved technologies have emerged, the SFPUC is now replacing high-pressure sodium lamps with LED lamps. White light sources are currently used in some areas and may be used in future development where more accurate color identification is desired or for areas that need color differentiation. In pedestrian areas (sidewalks and crosswalks), lamp technology that produces a blue or white spectrum light should be used.

New and replacement lamps should aim for a color temperature between 4,500 and 5,500. Existing lamps should be retrofit to meet the above target as funding allows.

### Light Poles and Fixtures

Street lighting fixtures illuminate both roadway and sidewalk and are typically 20 to 30 feet high. Typically, the taller the pole height, the larger the area each lighting fixture can illuminate. This means that the spacing between lighting fixtures can be wider and fewer fixtures can be used to light the street, which is economical for construction and maintenance.

Pedestrian-scale lighting fixtures, typically 12 to 15 feet high, illuminate pedestrian-only walkways and provide supplemental light for the sidewalk. Pedestrian-scale fixtures should be encouraged to improve pedestrian lighting on key streets, and considered in areas with high nighttime pedestrian activity and/or wide sidewalks. They should also be considered for narrow streets, including local access lanes, alleys, shared public ways, and pedestrian pathways, that can be adequately illuminated with these fixtures alone. In these situations, street lighting fixtures will most likely be required at intersections, at mid-block crosswalks, and on the through-lanes of multi-way boulevards.

The city should explore opportunities to encourage property owners, private developers, and public buildings to

install wall mounted or suspended pedestrian lighting fixtures for sidewalks, alleys, shared public ways, or pedestrian-only streets where conditions allow.

Light fixtures should be selected that are appropriate to the overall streetscape style and identity of the neighborhood and that maintain continuity between the different streets in the neighborhood. Neighborhoods should have a consistent fixture style to present a unified appearance, and similar neighborhoods around the City should have the same or similar fixture styles. Accessories such as banner arms may be added to light poles to further identify the neighborhood. Historic light standards (for example, the Path of Gold (Market Street)) lights should be preserved, and restored according to the Secretary of the Interior's Standards as funding allows.

To create a unified palette of fixtures throughout the City, with managed flexibility for unique neighborhood improvements, a coordinated street light master plan should be undertaken to develop standards for appropriate fixtures and more detailed location and technical criteria.

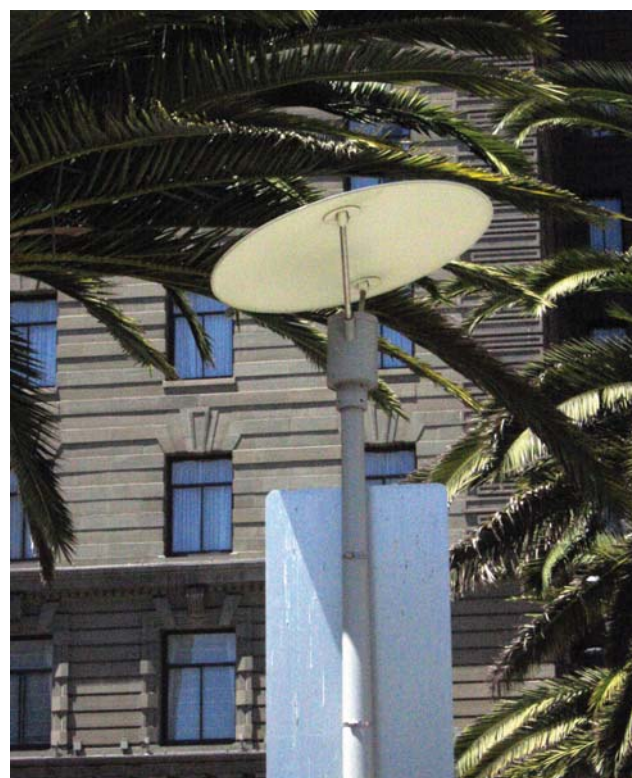

◀ Downward-facing lighting prevents excess light from trespassing into adjacent buildings

▶ Pedestrian lighting should share poles with street lights wherever possible to minimize streetscape clutter. However, light level and uniformity requirements should take precedence over pole consolidation.

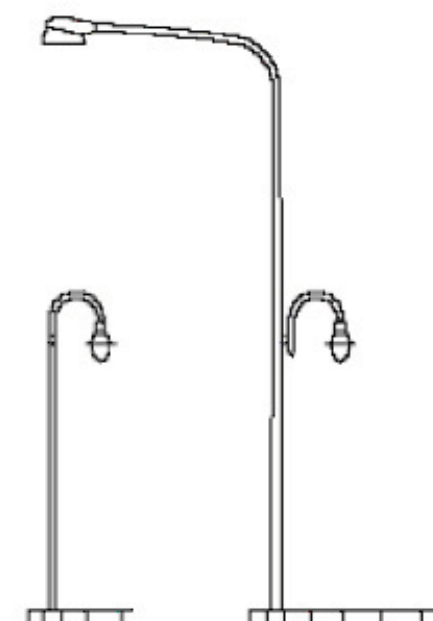

By day, the style of a light fixture has significant impact on the character of a neighborhood. By night, the light distribution of a fixture will define the visual environment and the fixture itself may be a design element in the streetscape. Both day and night characteristics of a light fixture should be considered when selecting appropriate fixtures for a neighborhood.

Light fixtures with an opaque top, no glowing lens (without features to make the fixture dark sky friendly), and an optical system that directs all light downward, such as a flat lens “cobra head,” present a low profile at night and direct attention to other elements in the streetscape. This type of light fixture should be prioritized on residential and small streets.

Fixtures that have a glowing lens such as a “teardrop” or “acorn” will be a visible element and a prominent part of the streetscape at night. There are decorative and historic advantages to using a lighting fixture with a glowing lens, but the fixture should be dark sky friendly and direct most of the light downward. This type of light fixture should be prioritized on civic or commercial streets.

Light fixture elements such as the pole and lamp should be proportional to each other, and their scale should be balanced with the surrounding building and roadway context.

The rhythm of the light poles should be consistent in a given neighborhood. On wide streets, light fixtures should be located on both sides of the street, and can be staggered or parallel depending upon light level and uniformity considerations. Light poles should have a consistent spacing with regard to trees and other street poles.

Where possible, street lighting should be combined with traffic light or Muni poles to reduce the quantity of poles on the sidewalk. However, light level and uniformity requirements should take priority over pole consolidation. In cases where attaching pedestrian lighting to existing roadway lighting fixtures still does not provide adequate pedestrian lighting, pedestrian lighting fixtures may need to be added between roadway lighting poles.

### Energy Efficiency

Energy efficient lamps produce a higher light output per watt than non-energy efficient lamps. In addition to the lamps, energy efficient fixture designs should be specified. A good optical system directs light to where it is needed and optimizes light output. Fixtures that direct light primarily downward toward the street rather than up toward the sky should be selected. New or replacement pedestrian and street lighting should aim to be a minimum of 50% more energy efficient than standard high pressure sodium fixtures. New or replacement pedestrian and street lighting should aim for a measurable efficiency of 70-115 lumens/watt, the efficiency level of current high-pressure sodium lights.

For further energy savings, the City may select to turn off certain lights later in the evening. For example, when pedestrian lighting is used to supplement street lighting to support high nighttime pedestrian activity, the pedestrian lighting may be turned off when pedestrian activity decreases late at night.

The City’s approved palette of light fixtures should be evaluated and updated to be compatible with the “smart controller technology system” to be managed by the SFPUC.

### Light Levels and Uniformity

The City currently does not have set standards for pedestrian light levels. As part of a future street lighting master plan, the City should create such standards. Preliminary targets for pedestrian light levels for each Better Streets Plan type are shown in Figure 6.9. These levels refer to **light directed on pedestrian zones** such as sidewalks, shared public ways, public stairways, and other pedestrian paths. Light levels are measured in foot candles (fc), which are approximately the distance (in feet) that is illuminated away from the source of light, measured in lumens per foot.

Pedestrian lighting should be provided on high pedestrian volume corridors or where a special design treatment is desired to supplement roadway lighting. Pedestrian lighting should be consistent throughout a block and minimize variance between bright and dark areas.

FIGURE 6.7  
ROADWAY LIGHT LEVELS

STREETScape TYPE	Horizontal light level range <sup>1,2</sup> at ground Minimum maintained average <sup>3</sup>	Uniformity ratio range <sup>1,2</sup> Average/Minimum
Downtown Commercial	Defer to Downtown Streetscape Plan	Defer to Downtown Streetscape Plan
Downtown Residential, Neighborhood Commercial (IESNA Roadway classifications: Major/Collector/Local)	0.5 to 1.7	3 to 6
Commercial Thoroughway (IESNA Roadway classifications: Major/Collector)	0.6 to 1.7	3 to 6
Neighborhood Residential (IESNA Roadway classifications: Collector/Local)	0.4 to 1.2	4 to 6
Residential Thoroughway (IESNA Roadway classifications: Major/Collector/Expressway)	0.4 to 1.2	3 to 4
Industrial Multi-way Boulevard <sup>4</sup> (IESNA Roadway classifications: Major/Collector/Local/Expressway)	0.4 to 1.7	3 to 6
Mixed-Use Parkway Park Edge (IESNA Roadway classifications: Major/Collector/Local)	0.4 to 1.7	3 to 6
Ceremonial (Civic)	Defer to potential subsequent design plan	Defer to potential subsequent design plan
Alleys, Shared Public Ways (IESNA Roadway classifications: Alley)	0.4 to 0.5	4 to 6
Paseos (IESNA classification: Pedestrian walkway)	0.4 to 1	4 to 6

1 Requirements in RP-8 are periodically revised and updated. Latest edition should be used for determining the light level and uniformity ratio requirements.

2 A range of light levels are listed. The exact minimum maintained average light level depends upon traffic and pedestrian volume and pavement classification (related to pavement reflection of light) for any given street. These variables must be verified for each street to determine exact minimum maintained average value. Verify technical classifications with the City for both roadway and pedestrian paths for individual streets.

3 Minimum maintained average is the lowest accepted value of an average light level calculated with a light loss factor.

4 A Multi-way Boulevard may have different roadway classifications for the thoroughway portion and the local access lanes of the boulevard. Local access lane lighting requirements will vary with adjacent land use context. Verify technical classification with the City for each street.

**FIGURE 6.8**  
**INTERSECTION/CROSSWALK LIGHT LEVELS**

FUNCTIONAL CLASSIFICATION	AVERAGE MAINTAINED ILLUMINATION AT PAVEMENT BY PEDESTRIAN AREA CLASSIFICATION (LUX/FC)		
	HIGH	MEDIUM	LOW
Major/Major	3.4fc	2.6 fc	1.8 fc
Major/Collector	2.9fc	2.2 fc	1.5 fc
Major/Local	2.6 fc	2.0 fc	1.3 fc
Collector/Collector	2.4 fc	1.8 fc	1.2 fc
Collector/Local	2.1 fc	1.6 fc	1.0 fc
Local/Local	1.8 fc	1.4 fc	0.8 fc

Light levels are measured in foot candles (fc) which refers to the distance (in feet) that is illuminated away from the source of light, measured in lumens per square foot.

Functional Classification of street types is based on IESNA standards.

**FIGURE 6.9**  
**PEDESTRIAN LIGHT LEVELS**

STREETScape TYPE	LIGHT LEVEL
Commercial	1 fc
Mixed-Use	0.5 fc
Residential	0.4 fc
Industrial	0.3 fc
Alleys and Paseos	0.3 fc
Special	Varies

Light levels are measured in foot candles (fc) which refers to the distance (in feet) that is illuminated away from the source of light, measured in lumens per square foot. Suggested light levels are consistent with ANSI/IES RP-8-00 American National Standard Practice for Roadway Lighting (see below)

**FIGURE 6.10**  
**COMPARISON OF STREETLIGHT TECHNOLOGIES**

LAMP TYPE	EFFICIENCY (LUMENS/WATT)	COLOR RENDERING INDEX (CRI)	LIFE (HOURS)
High Pressure Sodium (HPS)	60 to 140	22	24,000 to 40,000
Metal Halide	60 to 100	65 to 90	10,000 to 20,000
Induction	60 to 70	80	100,000
LED	50 to 100	70 to 80	50,000 to 100,000
Incandescent	9 to 20	96 to 99	1,000 to 2,000

In general, providing sidewalks with a minimum luminance of 0.5 fc allows pedestrians to detect obstacles, stay visually oriented, and recognize faces from a distance of 13 feet, a minimum distance that brings comfort with regard to normal social contact. For high crime or activity areas, higher values may be considered.

Crosswalks should follow Illuminating Engineering Society of North America (IESNA) intersection guidance to illuminate pedestrians in the crosswalk to vehicles (see Figure 6.8). Crosswalk lighting should provide color contrast from standard roadway lighting.

Lighting fixture spacing should be based on light level and uniformity requirements in the American National Standard Practice for Roadway Lighting (RP-8) by the IESNA, the adopted city lighting standard, shown in Figure 6.8. Roadway classifications used in RP-8 are based on traffic volume.

Light levels will decrease as lamps get old and lighting fixtures get dirty. Light levels should be adequate even when light levels decrease over time. Light level calculations should be performed using the light loss factor stipulated by the City to account for these anticipated decreases.

### Existing Light Fixtures – Inventory

Existing light fixture locations should be used wherever possible, but the lighting layout should meet light level and uniformity criteria and other considerations listed in this document. When selecting a fixture, if the SFPUC already has approved and/or is using the same style of fixture, approved fixtures should be used. The quantity of fixture types in the city should be minimized and consolidated to as few as practical while maintaining the aesthetic and technical requirements set forth in this document. New fixture types used in a single installation are discouraged.

The City’s approved palette of light fixtures should be evaluated and updated through a subsequent street lighting master plan.

## MAINTENANCE

### Manufacturer Selection

The lamp, parts and accessories for lighting fixture maintenance should be easily accessible in the fixture and obtainable in the market place. When specifying a lighting fixture, the ease of maintaining and replacing the ballast, lamp, lens and other major parts should be evaluated. Fixtures should be easy to maintain. A reasonable parts inventory should be maintained by the City for commonly replaced parts such as lamps, ballasts, and touch up paint. It should also be easy to obtain parts through a local distributor.

Only well established lighting, pole, and lamp manufacturers should be specified. If a lighting manufacturer used by the City goes out of business, another manufacturer with a similar style of fixture should be selected if a fixture or pole has to be replaced in the future. If custom designed lighting fixtures are proposed for a neighborhood, the City should retain ownership of the fixture design so it can be replicated by another manufacturer if the original manufacturer can no longer produce it.

New or replacement pedestrian and street lighting fixtures should be chosen to minimize maintenance and operating costs, and should have a lifespan of 50,000 hours.

### Tree Pruning

Tree pruning is important to maintain uniform light levels on the street. The clearance between tree foliage and the lighting fixture is dependant upon the tree type and lighting fixture type and height. See Section 6.1: Urban Forest.

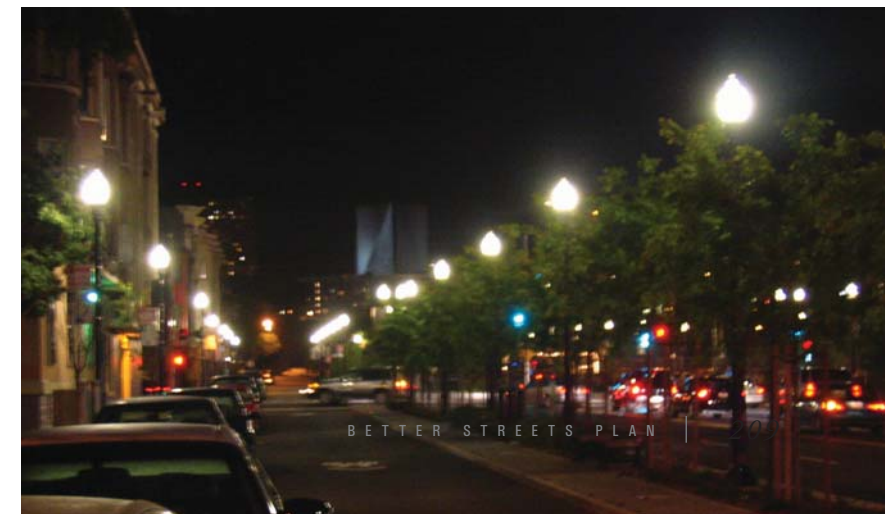



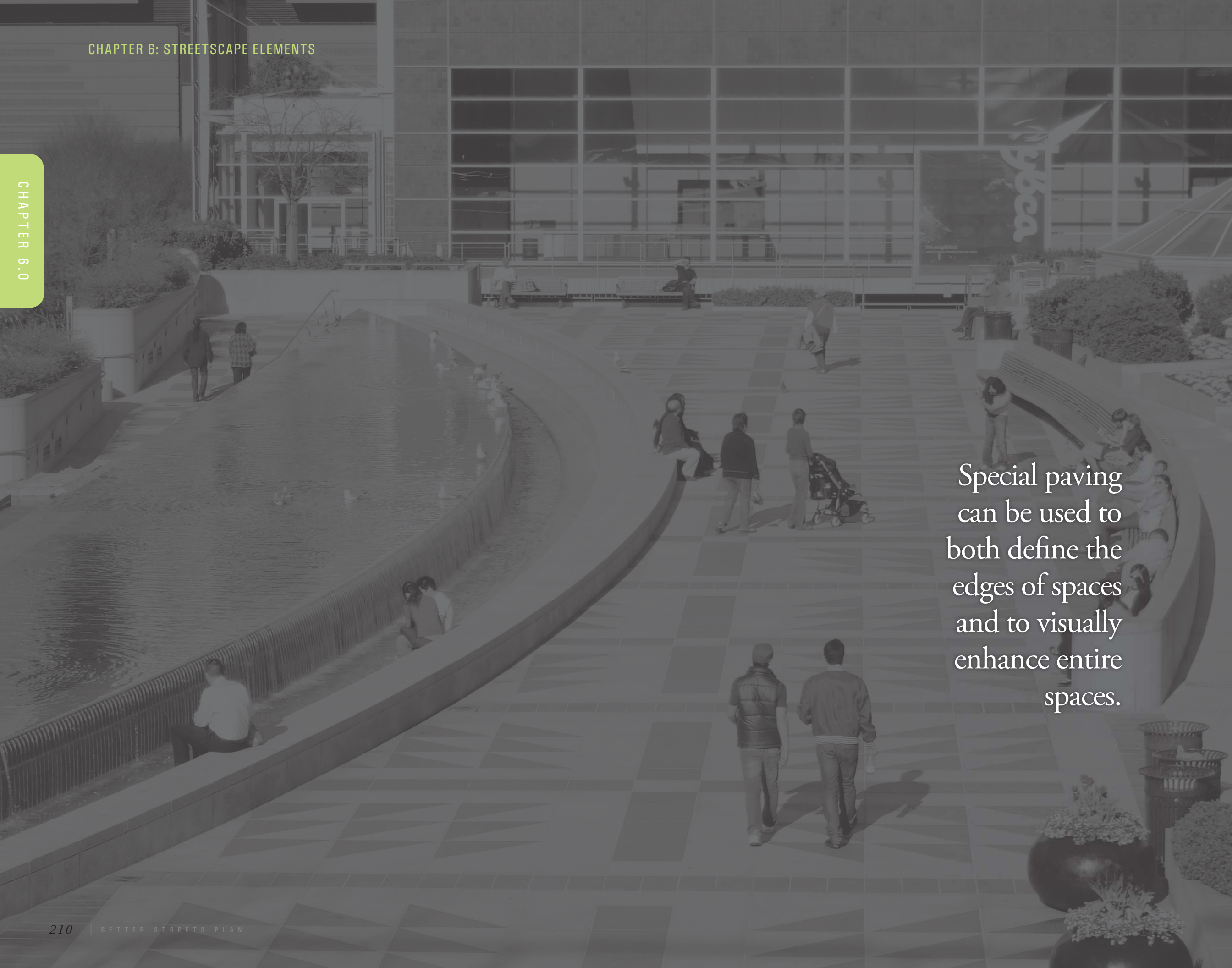

Special paving can be used to both define the edges of spaces and to visually enhance entire spaces.

# Paving

# 6.4

Paving can consist of traditional paving materials such as concrete or asphalt or non-traditional materials used as accents or in key locations. Typical asphalt and concrete paving are proven materials that meet the standard needs of vehicle and pedestrian circulation; special paving treatments can improve public spaces in a city, give circulation areas a stronger sense of place, and enhance the hierarchy of public spaces. Special paving treatments can be selected from a range of options, including natural stone pavers, unit concrete pavers, bricks, wood, textured and colored concrete, stamped asphalt, and concrete with exposed or special aggregate or other finish treatments.

Special paving can be used to both define the edges of spaces and to visually enhance entire spaces. Special paving is key to communicating pedestrian primacy such as within heavily traveled crosswalks or pedestrian priority spaces, and adds visual variety to the streetscape.

Special paving can be a functional stormwater amenity as well as an aesthetic enhancement, when designed as permeable paving. Permeable unit concrete pavers can provide both function and aesthetic appeal and should be used where an enhanced design treatment is desired. Permeable asphalt and concrete change the surface function but do not greatly enhance the overall aesthetics of the site. See Permeable Paving in Section 6.2.



## ➔ PLACEMENT

Sidewalks should use standard scored concrete paving at a minimum. In addition, special paving may be included as a component of any street type. Special paving is most appropriate on downtown, commercial, ceremonial, and other special streets or small streets. Specifically, special paving should be considered in:

- ➔ transit stop areas, including transit curb extensions and medians;
- ➔ pedestrian crossings, especially at important civic locations, neighborhood commercial areas, and other special districts;
- ➔ mid-block and raised pedestrian crossings;
- ➔ pedestrian refuge areas within medians;
- ➔ the full right-of-way of shared public ways;
- ➔ local access lanes of multi-way boulevards;
- ➔ pedestrian-only streets, including transit malls, pedestrian malls, and areas that are regularly but temporarily closed to vehicle traffic;
- ➔ flexible space in parking lanes;
- ➔ sidewalk and median pocket parks;
- ➔ curb extensions;
- ➔ the furnishings zone of sidewalks;
- ➔ driveways; and
- ➔ gateways and other special places.



▲ Special paving across the full right-of-way



▲ Special paving in the sidewalk

## 🔧 GUIDELINES

### Paving type

**Standard Paving:** Standard sidewalks should use concrete scored in 3' x 3' squares.

Downtown sidewalks should use concrete mix to the specifications of the Downtown Streetscape Plan.

**Special Paving:** Pavers consist of sand set pavers, mortar set pavers, and permeable or porous pavers over clean drain aggregate. Special pavers include natural stone pavers, unit concrete pavers, unit concrete permeable pavers, textured and colored concrete, stamped asphalt, concrete

with exposed or special aggregate, and other finish treatments. Special aggregates, colors, and textures may also be considered. Maintenance cost of special pavers should be considered during the selection process.

When non-customary materials are used, they should extend at least a complete block for design consistency and maintenance efficiency. Similarly, non-customary scoring should extend for at least one block. Exceptions can be made where special paving is being used to highlight transit stops, parks, plazas, or other site-specific features.

## ➔ Permeable Paving

Permeable paving materials not only create attractive streetscapes but can serve an important ecological role in improving the sustainability of streets. See Section 6.2: Stormwater, for detail.



### Accessibility

Special attention should be paid to accessibility and comfort considerations of paving materials in selecting appropriate locations for different paving types. Paving materials must meet all accessibility standards. Generally:

- Paving materials should not pose tripping hazards or cause excessive vibration for wheelchairs
- Paving should be designed, installed, and maintained to be smooth and level. Surfaces should not be interrupted by steps or abrupt changes in level of more than 1/4 inch.
- Unit pavers must have gaps of no more than 1/4 to 1/2 inch, beveled to no more than a 1:2 ratio.
- Saw cut joints in poured concrete are preferable to troweled joints

- Surfaces with a slope of less than 6% gradient should be at least as slip-resistant as what could be described as a medium salted finish. Surfaces with a slope of 6% gradient or more must be slip-resistant.
- Surface cross slopes should not exceed 1/4 inch per foot except where, due to topography, it creates an unreasonable hardship, in which case the cross slope may be increased to a maximum of 1/2 inch per foot.

Refer to the guidelines below and ADA and Title 24 standards for more information. See DPW standard engineering plans for sidewalks for construction details.

Specific guidance for design of curb ramps is presented in Section 5.1. Curb ramps should be treated in either smooth solid concrete or paving treatment to match adjacent paving.

### Installation

Special paving materials should follow these guidelines:

- Select surface materials with low maintenance requirements and high durability, slip-resistance, and compressive strength.
- Retain a certified geotechnical engineer and reference a geotechnical investigation report for soil type and loading capabilities.
- Understand soil type and settlement potential when choosing a paving surface material and sub-base thickness.
- A proper sub-base is as important as the surface material. Use of a recycled sub-base is recommended. Ask suppliers of recycled materials to provide material testing results for loading equal to Caltrans classification standards.
- Understand the loading needs per the expected use (trucks, emergency vehicles, vehicles, pedestrian-only). The paver and sub-base depth should be designed for the heaviest expected loading per City standards. A concrete slab with mortar pavers is recommended in high traffic areas with heavy loading for long-term durability.
- Settlement may be an issue in areas of high clay content or over “Bay Mud”. An enhanced sub-base or concrete slab base is typically required per geotechnical recommendations.
- Follow manufacturer recommendations for maximum slopes and minimum recommended sub-base depth and material.
- Conduct percolation tests or soil science reports if permeable or porous pavers are used. Where infiltration is not feasible, an underdrain may be used.

### Layout

Special paving can be implemented as a field treatment, consistent across the entire sidewalk, plaza, or shared space, or can define specific areas within the streetscape. Where implemented as a field treatment, it should be organized in regular or organized artistic patterns.

*Special paving at specific locations*

Special paving should be considered for installation in the following locations subject to the guidance elaborated in the related sections of this document. Recommendations are summarized below.

**Furnishings Zone (see Section 4.2):** Special paving in the furnishings zone can visually separate this space from the rest of the sidewalk, highlighting its function as an area to sit or step out of pedestrian flow. Permeable paving, such as pavers set on a clean aggregate gravel subbase, should be used where possible to allow stormwater infiltration, water, and oxygen to reach tree roots below.

**Pedestrian Crossings (5.1):** Special paving treatments communicate to individual users that the crosswalk is part of

- ▼ Special paving can define the transit waiting and circulation area for pedestrians, even where a shelter is not present



pedestrian space, not an encroachment by pedestrians into the roadway. Paving, texture, and color treatments are especially important in places where it is important to make pedestrians more comfortable crossing.

The application of special paving in crosswalks should consider wear and tear caused by vehicles crossing the paving, and requires additional capital and maintenance funding. The paving should be designed and installed to maintain the desired visual and textural appearance. Special paving is not a substitute for standard or high-visibility retro-reflective crosswalk markings. Standard 12 inch transverse lines should still be used outside a decorative crosswalk treatment to establish a marked crosswalk.

**Curb Extensions (5.3):** Where curb extensions are added, they may be designed as useable pedestrian spaces. Special paving can reinforce this intention by visually separating curb extensions from the adjacent sidewalk, and suggesting that these spaces are meant for sitting and relaxing as opposed to just walking.

**Pedestrian Refuge Areas in Medians (5.4):** Special paving should be considered at pedestrian refuges. The pedestrian

- ▼ Special paving at crossings and on pedestrian refuges makes crossing more comfortable for pedestrians



path through the median and adjacent areas may include special paving.

**Transit Stops (5.5):** Special paving treatments should be considered at transit stop locations to define the waiting zone and to clarify connections to transit. Curb extensions and transit boarding islands should be paved with finer-grained paving treatments ranging from unit pavers to special scoring and color in concrete. At transit stop locations where there is no curb extension, distinctive sidewalk treatments such as alternative paving or scoring patterns or an edging treatment in the furnishings zone should be considered.

The sidewalk throughway adjacent to transit stops should be treated similarly to the surrounding sidewalk area to distinguish the transit stop area from the sidewalk throughway zone.

**Flexible Space in Parking Lanes (5.6):** Where parking lanes are re-designed as part of a program of flexible use, special paving should be used to differentiate the parking lane from the adjacent vehicular travel lane and the furnishings zone from the throughway zone. Special paving should be used to designate the outdoor rooms meant for people to sit and relax.

**Pocket Parks (5.8):** Special paving should be considered as an edging treatment around sidewalk pocket parks and planting areas. Travel lanes adjacent to these areas can use special paving to indicate a shared space where pedestrians may cross the street from the sidewalk to the open space. Within such spaces, permeable pavers and other alternative permeable surfaces such as decomposed granite are highly recommended for paths, edging, and other hardscape areas.

**Shared Public Ways (5.8):** On shared public ways, special paving is integral to communicating that the entire right-of-way is a space to be shared between pedestrians and vehicles. Paving patterns and layout should be used to convey the location of spaces within the right-of-way, defining the edges for parking, playing, and sitting, and highlighting the edges of planting areas.

**Multi-Way Boulevards (5.8):** Special paving can be used to communicate the function of the local access lane in bou-



- ▲ Unique paving treatments convey a sense of scale, detail and orientation that is welcoming to pedestrians

- ▼ Paving treatments can be used to accent the sidewalk by outlining trees or entire sidewalk zones



levards. Special paving should be considered for the entire lane to enhance this function. The change in material identifies a space intended for local circulation and that differs from the through lanes in the center of a multiway boulevard, particularly in combination with a shared public way treatment or raised crossings.

**Pedestrian-Only Streets (5.8):** Where a whole right-of-way is converted to pedestrian space or special mixed transit and pedestrian space, or where frequent temporary closure for pedestrian use is considered, special paving should be used to enhance the space for pedestrians. Special paving should be used to define and highlight spaces within the public right-of-way, breaking the space down into a more pedestrian scale.

**Driveways (6.6):** Driveways outside the path of travel can use interlocking pavers, pervious concrete, and other similar materials to add visual variety to the streetscape, and allow infiltration where appropriate.

## OTHER CONSIDERATIONS



### Environmentally responsible material choices

Many paving surfaces, sealants, coatings, traffic markings, and other products are composed of materials that are harmful to the natural environment. The type of material selected should consider the level of volatile organic compounds (VOCs) and specify zero- to low- VOC agents. Polycyclic aromatic hydrocarbon (PAH)-free sealants and/or asphalt bases should be considered.

Many paving surfaces are composed of natural materials derived from highly impactful quarrying and processing methods that are damaging to the natural environment. The City should encourage the use of recycled or reclaimed materials. Granite curbs removed during retrofit should be reused, either on-site or on other streetscape projects.

Streetscape projects should strive to use sustainable paving materials, including:

- **Materials with recycled content:** the sum of post-consumer recycled content plus one-half of the pre-consumer content constitutes at least 20% (based on cost) of the total value of the materials in the project
- **Regionally-harvested materials:** materials or products that have been extracted, harvested or recovered, as well as manufactured, within 500 miles of the project site for a minimum of 20% (based on cost) of the total materials value
- **Rapidly renewable materials:** materials and products made from plants that are typically harvested within a ten-year cycle or shorter for 2.5% of the total value of all materials and products used in the project, based on cost.

The City is currently working on a 'greening checklist' for streetscape projects that would institutionalize these standards.

Site furnishings announce that pedestrians are welcome and that the street is a comfortable place to be. These amenities provide a functional service to the pedestrian and provide visual detail that makes a place comfortable and interesting.

# Site Furnishings

## 6.5

Site furnishings provide important amenities for pedestrians by adding functionality and vitality to the pedestrian realm. They include benches and seating, bicycle racks, bollards, flowerstands, kiosks, newsracks, parking meters, public art, sidewalk restrooms, streetscape signage, traffic and parking signs, trash receptacles, and other elements not specifically discussed here. Transit shelters are discussed in Section 5.5.

Site furnishings announce that pedestrians are welcome and that the street is a comfortable place to be. These amenities provide a functional service to the pedestrian and provide visual detail and interest.

Pedestrian amenities should be considered a requisite public expenditure just as other necessary elements of the street, such as traffic signals and signage. Improved street vitality has marked impacts on public safety and comfort, health of local businesses, local real estate value, and transportation habits<sup>1</sup>.

<sup>1</sup> Case Study No. 20: *The Effects of Environmental Design on the Amount and Type of Bicycling and Walking*, National Bicycling and Walking Study, US Federal Highway Administration.

### ➔ In this section: Site Furnishings

- Benches and seating
- Bicycle racks
- Bollards
- Flowerstands
- Kiosks
- Newsracks
- Parking meters
- Public art
- Sidewalk restrooms
- Streetscape signage
- Temporary private use of the public realm
- Traffic and parking signs
- Trash receptacles





## ➔ PLACEMENT

Site furnishings should be prioritized on:

- ➔ streets with a large amount of pedestrian activity;
- ➔ streets where pedestrians may linger and enjoy the public realm, such as downtown, commercial, mixed-use, or special streets; and
- ➔ streets with a recreational role such as parkways, park edge streets, and boulevards.

Other streets should include site furnishings at corners and busier blocks, or where warranted by adjacent land use and pedestrian activity. Site furnishings should be clustered at transit stops. See Section 5.5.

On residential streets, alleys and on curb extensions on any street, clusters of pedestrian amenities can create attractive and inviting public spaces where neighborhood residents or patrons of local businesses can sit and rest, play, eat, or enjoy people watching.

Specific location guidelines for each element are detailed by element on the following pages.

## 🔍 GUIDELINES

### General

Layout of site furnishings should follow the guidance provided in Section 4.2. Specific guidance for furnishing layout at transit stops is provided in Section 5.5.

Site furnishings should be considered secondary to street trees and lighting. Street tree and lighting placement should define the major rhythm of design elements along the street; site furnishings should be placed in relation to trees and lighting after the best locations for these elements have already been located.

In downtown, site furnishings should follow the Downtown Streetscape Plan.

In addition to the specific guidelines for each element, site furniture should conform to these minimum requirements for sidewalk element placements, unless otherwise noted. Site furnishings should be placed in the furnishings zone not less than:

- ➔ 18 inches from the outside edge of the curb;
- ➔ 2 feet from any driveway or wheelchair ramp and 4 feet at the landings of the ramp;
- ➔ 5 feet from any fire hydrant and 2 feet from a stand pipe; and
- ➔ 4 feet from any MUNI transit shelter, except as noted in Section 5.5.

Placement of site furnishings should consider car overhangs and door swings. When placed near the curb, furnishings should be located at the ends of the on-street parking stalls rather than at the center.

Street designs should reduce streetscape clutter by consolidating and reducing the size of miscellaneous site furnishings such as utility poles, call boxes, mail boxes, etc. as much as possible.

Site furnishings may also be placed within curb extensions where sidewalk widths are extended into the parking lane. Dining areas for adjacent restaurants can be located on curb extensions, in flexible parking areas, or in the furnishings zone. See Section 5.3: Curb Extensions and Section 5.6: Parking Lane Treatments.

San Francisco should create a unified, replicable palette of site furnishings that can be customized to reflect the local character of the surrounding neighborhood to contribute to a sense of community identity.

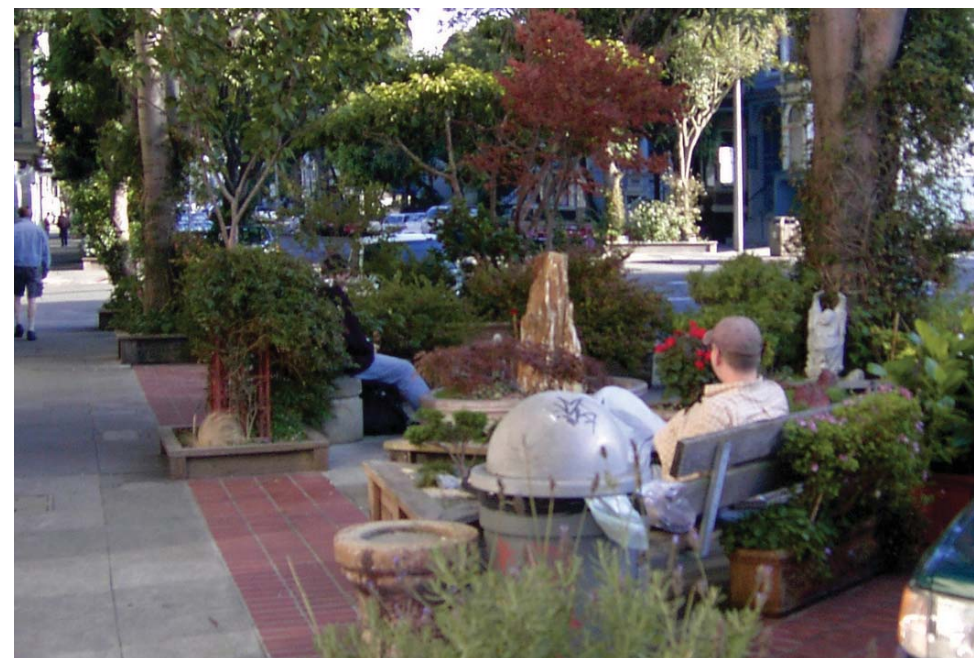

### Accessibility Requirements

All site furnishings must be accessible per Americans with Disabilities Act (ADA) guidelines and City regulations, including the following:

- ➔ Site furnishings must maintain the minimum 4 foot ADA required clear accessible route, and should leave the minimum through widths described in Section 4.2.
- ➔ Objects mounted on walls or posts with leading edges above the standard sweep of canes (27 inches) and below the standard head room clearance (80 inches) should be limited to a 4 inch maximum protrusion.
- ➔ No sidewalk element may interfere with pedestrian access to the entrance of any building; this includes the path of travel and disabled access requirements of ADA and Title 24. This includes all paths of travel or exiting.



## Design Considerations for Accessible Furnishings

Technical provisions for accessible features appropriate to pedestrian facilities may be found in the following sections of ADAAG:

- 4.4 Protruding objects
- 4.15 Drinking fountains
- 4.22 Toilet facilities
- 4.27 Controls and operating mechanisms
- 4.29 Detectable warnings
- 4.30 Signage
- 4.31 Public pay telephones
- 4.32 Fixed or built-in seating and tables

The US Access Board web site [www.Access-Board.gov](http://www.Access-Board.gov) contains proposed and new accessibility guidelines for the Americans with Disabilities Act, the Public Right-of-way and for outdoor recreation that may be appropriate best practices for pedestrian facilities.



▲ Seating can be oriented in social layouts or in individual locations to allow people to converse or to sit alone

- Wherever possible, site furnishings should be of a contrasting color to the sidewalk so as to aid pedestrians with visual impairments.
- Site furnishings should leave a minimum 8 feet of clearance adjacent to accessible parking and passenger loading zones.

See Appendix E for a full summary of accessibility guidelines.

### Environmentally responsible material choices

Site furnishings should strive to use sustainable materials, including:

- **Materials with recycled content:** the sum of post-consumer recycled content plus one-half of the pre-consumer content constitutes at least 20% (based on cost) of the total value of the materials in the project.
- **Regionally-harvested materials:** materials or products that have been extracted, harvested or recovered, as well as manufactured, within 500 miles of the project site for a minimum of 20% (based on cost) of the total materials value.
- **Rapidly renewable materials:** materials and products made from plants that are typically harvested within a ten-year cycle or shorter for 2.5% of the total value of all materials and products used in the project, based on cost.
- **Certified wood:** use a minimum of 50% of Forest Stewardship Council's (FSC) certified wood-based materials for wood components.

The City is currently working on a 'greening checklist' for streetscape projects that would institutionalize these standards.

### Benches and seating

Public seating warrants particular attention because it creates a comfortable, useable, and active public environment where people can rest, socialize, read, or people-watch. It is a simple gesture that can go far to create an important sense of place. Seating creates places where people can see and be seen. This ability to entice people to linger is the hallmark of great and successful public spaces.

#### Location of benches and seating

Seating arrangements should be located and configured according to the following guidelines:

- Seating should be located under trees where possible to provide shade and comfort and to integrate multiple elements.
- Informal seating (low walls, etc.) may also be incorporated into other elements in the site furnishings zone, such as planter edges. Where space allows, benches can be built into planters.
- Where seating is oriented parallel to the curb, it should face toward buildings when located in the furnishings zone, or away from buildings when located in the frontage zone.
- Where sidewalk width permits, seating in the furnishings zone should be perpendicular to the curb.
- On curb extensions, seating should be organized to create social spaces.
- Seating incorporated into building forms, such as seat-walls, may be used as an alternative to free-standing benches.
- Seating should be designed to encourage sitting and to discourage lying down.

Given the visual character and amenities in San Francisco and the areas around it, there are many scenic locations where varying from some of these guidelines may be appropriate in order to take full advantage of a street's setting.

For example, seating may be oriented towards a view, rather than towards a street when doing so would provide an additional amenity.

Unfortunately, in some cases fear of loiterers has resulted in seating that is so uncomfortable that no one would want to use it, or the removal of pre-existing seating altogether. The City should maintain a strong presumption against removing seating in the public right-of-way, and should include seating as a standard pedestrian furnishing in new streetscape design projects to encourage usability and activation of the public realm.

**Design of benches and seating**

Seating and other amenities should be made of durable, high-quality materials. Seating should complement and visually reinforce the design of other streetscape elements.

Seating should be designed as an integrated part of other streetscape elements where possible, including:

- integrated seat walls in pedestrian refuges;
- seat walls and benches around trees and landscaping;
- part of public art and gateway monuments; and
- other elements where integration improves utility of the element to pedestrians without compromising its primary function.

50% of public benches in a group, or at least 1 bench, must be ADA accessible. See Section 4.32 of ADAAG.

Temporary or moveable seating may also be used, particularly in locations where there is active street management by adjacent businesses, a merchant’s association, or the like. Temporary seating allows people to orient seats to meet specific social and microclimate needs. Moveable seating and tables for sidewalk dining must comply with DPW permit requirements. See Temporary Private Use of the Public Realm, this section).

**Bicycle racks**

Detailed discussion of bicycle racks can be found in the San Francisco Bike Plan; this plan focuses on design and interaction with other streetscape elements. Bicycle racks are an important element of the streetscape, both as an aesthetic aspect of the streetscape and as a functional element for those who travel by bike. According to the 2000 US Census, San Francisco has the highest percentage of residents who commute to work by bicycle among cities with a population of 500,000 or more.

Bicycle racks are also opportunities for distinctive design and public art elements. Where part of a special maintenance or public art program, uniquely designed yet functional bicycle racks are encouraged.



▲ Seating should be integrated with other elements, such as tree guards, where possible



▼ Bike racks should be located near other streetscape elements, such as trees and planters, to cluster amenities



**Best Practice: Mint Plaza**

San Francisco, California

Mint Plaza is a former alley that was recently converted to a pedestrian plaza. Mint Plaza is a finely detailed pedestrian space, with high quality paving stones, attractive trellises and landscaping, and small businesses including new cafes. The plaza was designed with detectable and discernable edges following the original sidewalks to provide a clear path of travel for people with visual impairments.

The plaza has a variety of landscape features with built in seat walls as well as a number of tables and chairs that can be moved to allow people to rearrange the furnishings to fit their needs or comfort, adding chairs for bigger groups or moving into the sun or shade to be more comfortable. This high level of design detail and the freedom to set up a table anywhere on the plaza allows pedestrians to feel comfortable using this urban space.



◀ Parking lane bicycle racks should be considered at popular destinations, such as this one at the San Francisco Main Library



◀ Bike racks can be combined with other streetscape elements such as tree guards

▼ Appropriate bike rack placement  
LEFT: Wide sidewalks (generally > 12')  
RIGHT: Narrow sidewalks (generally < 12')

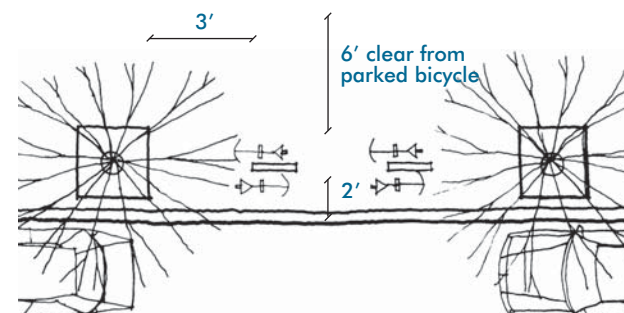
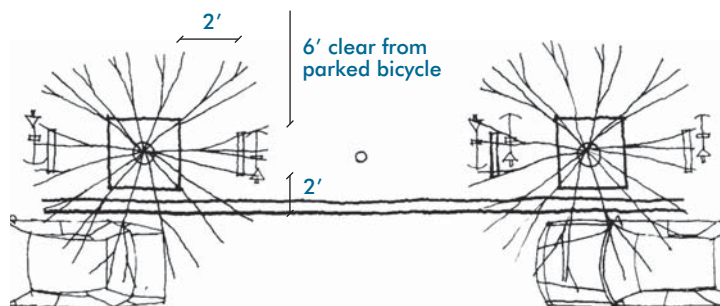

### Location of bicycle racks

Bicycle racks should conform to SFMTA's bicycle rack placement criteria.

Bicycle racks should be located according to the following guidelines:

- Bicycle racks should be frequent in active commercial districts. Racks should be provided near major destinations such as schools, libraries, transit stops, major shopping and service destinations, and other locations with high pedestrian traffic.
- Where parking meter consolidation programs (as described later in this section) are implemented, bike racks should be provided to replace meter poles, or meter poles should be retrofitted with rings to allow bike parking.
- Racks should be located in either the furnishings zone or on curb extensions where possible. Racks should not be placed at accessible parking or passenger loading zones.
- At transit stops, bike racks should be placed near the back of the transit stop, further from the shelter (where present), or be placed outside of but adjacent to the transit stop. Bike-sharing pods, where provided, should be placed outside of but adjacent to the transit stop.
- Placement and spacing of bicycle racks should consider dimensions when occupied.
- Bike racks placed in the furnishings zone should be perpendicular to the curb where sidewalks are wide enough so that bikes parked at them do not project

into the throughway or edge zone. Where this space is not available, bike racks should be placed parallel to the curb. Perpendicular bike racks should be placed at either edge of a tree basin, a minimum of 2 feet from the edge to allow a person to easily pull their bike in and out.

- A rack should be at least 2 feet from the curb, with 3 feet preferred.
- Bicycle racks should not be located directly in front of a store/building entrance or exit or in a driveway.
- There should be at least 3 feet of clearance between bicycles parked at racks and any other street furniture, with the exception of other bike racks, which should be placed a minimum of every 3 feet on center.
- Bicycles parked at a rack should have a minimum 1 foot clearance from utility vaults.

**On-street bike parking:** Where sufficient demand exists or where sidewalk space is constrained, replacing an on-street vehicle parking space with bicycle parking should be considered. See Section 5.6.

### Design of bicycle racks

Design and selection of bicycle racks should be designed to the following guidelines:

- The inverted “U” rail rack is the preferred rack for normal sidewalk installation.
- A bike rack should be sturdily attached to the ground to prevent theft
- Galvanized or stainless steel materials that are not powder-coated are more secure and are easier to maintain; where there is a specialized streetscape palette with particular design scheme, bicycle racks should be considered that match other site furnishings.



The inverted “U” rail rack is the preferred rack for most sidewalk installations

- All elements of a bike rack should have a minimum 2 inch diameter (or 2 inch square tube)
- Racks should offer a minimum of 2 points of support for bikes unless the rack can support a bike in two places, such as a post and ring configuration

New designs that integrate decorative tree guards with bicycle parking should be considered for their efficiency in providing more benefit to the streetscape and maintaining more open space on the sidewalk. Artistic bike racks or racks integrated with other elements should also follow the above recommendations.

New development should be encouraged or required to install on-street bike racks as part of development approvals where appropriate.

**Bike sharing:** Bike sharing, if implemented in San Francisco, will require a substantial number of new bicycle racks throughout the City. In such circumstances, conversion of on-street parking to bicycle parking may be necessary. See Section 5.6.

### Bollards

Bollards are primarily a safety element to separate pedestrians or streetscape elements from vehicles. Attractively designed bollards add color and interest to streetscapes, help define pedestrian spaces, and provide a spot to lean on or rest at.

#### Location of bollards

Bollards should be located according to the following guidelines:

- Bollards should be used at sidewalk locations where vehicles attempting to park are damaging sidewalk structures, trees or plantings, furnishings, or adjacent private property, especially on narrow streets.
- Bollards should be considered for installation on median islands, curb extensions (except transit bulb-outs), and mid-block curb extensions, where there is a risk of danger to pedestrians due to proximity of travel lanes.

- Attractive bollards can also be used in special locations, including pedestrian-oriented spaces such as shared public ways or pedestrian-only streets, to designate unique spaces. Lighted bollards can create a special pedestrian environment, and may be particularly useful to provide additional pedestrian lighting in median refuges.
- Removable bollards should be placed at entrances to streets that are closed to vehicles for pedestrian use, to alert drivers to the changed nature of the street. Similarly, removable bollards can define the outside edge of flexible parking spaces (see Section 5.6) where the space has been converted to pedestrian use.
- Bollards should be placed 18 inches from the back of the curb. If there is no parking in the bollard placement area, the bollard may be installed immediately adjacent to the back of the curb.
- Standard bollard spacing is approximately 10 feet on center, but may need to be reduced where there is a need to block vehicular traffic. Spacing should vary to sync with the rhythm of lighting fixtures, trees and landscaping, or other elements in the streetscape.

#### Design of bollards

Bollards typically range in size from 4 to 10 inches in diameter; decorative bollards can be larger and vary in form.

Bollards should have articulated sides and tops to provide design detail. Bollards should be painted in colors other than gray to be easily seen by the visually impaired, in colors that complement other streetscape elements. Bollards should be designed within a 'family' of streetscape elements.

In circumstances where bollards are used to temporarily close a street or flexible parking space, removable bollards should be designed with long sturdy pipe projections from the bottom that fit into a hole in the ground. Removable bollards should be designed and installed such that, when in place, they are sturdy and look permanent. Electronic retractable bollards that can be lowered into the roadway to selectively allow vehicles to pass, should be considered where streets are closed to allow emergency vehicle access.



▲ Bollards protect pedestrians from passing traffic and can be an attractive streetscape accent



▲ Bollards come in a variety of sizes and designs.

## Flowerstands

Flowerstands should not exceed 3 feet in width and 10 feet in length. The total flowerstand area (including displays) should not exceed 5 feet in width and 20 feet in length.

A minimum of 6 feet clear pedestrian passage between the edge of the display area and other objects should be maintained on the sidewalk at all times in front of flower stands.

For flowerstands outside of the public right-of-way, only temporary displays should be located in the public sidewalk area. These displays should not exceed 2 feet in width.



▲ Pedestal-mounted newsrack

## Kiosks

Kiosks are public elements that are sources of information, and may include maps, bulletin boards, or other useful information. Kiosks can often be combined with gateway signage and provide an attractive and useful streetscape element.

### *Location of kiosks*

Kiosks should be located according to the following guidelines:

- Kiosks should be located in the furnishings zone, leaving required throughway and edge zone widths.
- When more than one kiosk is installed on a street, all kiosks should be placed on the same axial line at regular intervals.
- Public service kiosks (those primarily providing information) should be separated by at least 150 feet per block face with a maximum of two kiosks per block face. No more than two kiosks should be placed at any intersection.
- Whenever possible, public service kiosks should be placed at red curb zones that are not transit stops.
- Whenever possible, Kiosks should be placed on corner and mid-block curb extensions.
- Kiosks should not be placed within transit stops.
- Kiosks should be placed such that they do not block scenic views.

### *Design of kiosks*

Kiosks should be designed to the following guidelines:

- Kiosks should communicate information by including bulletin boards for community posting, enclosed cases for display of city information, or permanent lettering. Where a kiosk serves as a gateway element it should include a neighborhood, commercial district, street, or park name or other information.

- Sidewalk kiosks must conform to the guidelines outlined in Department of Public Works Order 163,368.
- When more than one kiosk is installed on a street, all kiosks should be of the same, or complementary, design and scale.
- Kiosks can be artistic and expressive. They should reflect an area's special character through their design and can be integrated with public art.
- Kiosks should include braille and be multi-lingual as necessary and appropriate to the specific location.

## Newsracks

In addition to the following guidelines, newsracks are subject to all of the guidelines in the City and County of San Francisco Public Works Code, Part II, Article X, Section 5.4 and all applicable Department of Public Works orders.

### *Location of newsracks*

Newsracks should be located according to the following guidelines:

- The ideal location for a newsrack is next to a red curb that is not marked for a bus stop.
- Only 1 six-unit pedmount newsrack may be placed behind the curb of any passenger loading (white) zone.
- Newsracks should be placed in building setbacks, instead of the furnishings zone wherever possible, with the property owner's approval.
- Where newsracks are located in the furnishings zone, placement should meet the minimum clear width with the newsrack door open. This clear width should be at least 8 feet in downtown areas per the Downtown Streetscape Plan.
- Newsracks should be placed no closer than 2 feet from adjacent street signs and 4 feet from bike racks.

- No newsrack should be placed within 6 feet of the curb for the length of any bus zone.
- A maximum of five free-standing newsracks may be placed in a continuous row. No more than two ped-mount newsracks may be placed within 5 feet of each other except if the sidewalk is 25 feet wide or greater, in which case up to 3 pedmounts can be placed.

**Design of newsracks**

Where possible, newsracks should be consolidated into a single integral cabinet. The cabinet should have an attractive, clean, and simple design that complements the design and color of other street furniture. Newsracks should be permanently affixed to the sidewalk

**Parking meters**

Parking meters are commonly found on downtown and commercial streets. Parking meters can be either traditional single-space meters or consolidated multi-space meters.

Many cities are moving toward multi-space meters as a parking management tool. Multi-space meters also have an important impact on streetscape aesthetics and, where implemented, should consider the recommendations of this section. Consolidating parking meters can reduce the number of poles in the sidewalk by combining multiple parking meters on a block face, resulting in a less cluttered visual environment. This may allow for the installation of additional trees or site furnishings.

**Placement**

Single space meters should be placed in the edge zone. They should be placed at the front end of individual parking stalls.

Multi-space meters may be placed in the edge zone or furnishings zone. Consolidated parking meters typically require installation of an entire new unit, and cannot be affixed to existing meter poles. Typically, multi-space meters should be placed every 8 to 10 parking spaces, roughly 150 to 200 feet apart.

Signage should clearly direct patrons to the multi-space parking meter. Signage directing patrons to multi-space meters should be placed every 100 feet (4 to 5 parking spaces).

**Design and consolidation**

From a streetscape design standpoint, the City should encourage the conversion of single space meters to multi-space meters to reduce the number of elements in the streetscape. However, the decision to convert should be made on the basis of parking management considerations.

When converting single-space meters to multi-space meters, old parking meters and poles should be removed. When meter poles are removed, consideration should be given to adding bicycle racks along the street to replace bicycle parking lost from removal of meter poles.

Multi-space meters should be selected to minimize their footprint on the sidewalk.

Some payment mechanisms require striping, and in some cases numbering, of individual spaces on the roadway while others allow cars to freely fill in the entire block. Where roadway striping and/or numbering is required it should be minimal and not visually distracting or unnecessarily large.

Technical provisions for controls and operating mechanisms may be found in section 4.27 of ADA Accessibility Guidelines.

**Public art**

Public art is an important aspect of major streetscape design projects. On a large scale, public art has the ability to unify a district with a theme or identify a neighborhood gateway. At a pedestrian scale, it can provide visual interest for passersby.

Public art is not a replacement for good urban design. Public art can add interest and delight to a pedestrian's experience. However, streets and all streetscape elements should also be designed to promote pedestrian and public space use.



▲ Multi-space parking meters are used in many cities across the country



▲ Mundane objects such as water fountains can incorporate public art



### ➔ Best Practice: Growing Vine Street

Seattle, Washington

This proposal for Seattle's Vine Street seeks to integrate public art and ecological considerations. The project's main objectives are to reveal and re-introduce the natural hydrologic cycle into the urban setting; create a neighborhood green space; and provide opportunities for functional public art.

The project's central concept is to create a "runnel" (a narrow water channel) lined with native greenery along the entire eight-block length of the street. Stormwater would be collected through large roof cisterns and would be discharged into the runnel for treatment and filtration.

#### *Location of public art*

Public art should be located on streets and in public spaces with high volumes of pedestrian traffic, particularly at key points or intersections. It may also be located in areas where few people pass to create unique and special places for people to enjoy. Downtown streets and boulevards are particularly appropriate for the former, while stairways and pathways provide unique spaces, often distinct to San Francisco, that fulfill the latter.

Arts Commission approval is required on projects that create new structures in the right-of-way per Section 3.19 of the Administrative Code (the Public Art Ordinance).

#### *Design of public art*

Public art is unique to each situation; however, the following guidelines apply:

- ➔ Public art should be located so as to be a pedestrian amenity. A piece can act as a focal point in a park or plaza or present a "surprise" along a pedestrian path that rewards the passerby with visual interest.
- ➔ Consideration should be given to incorporating art into otherwise standard street elements such as light poles, benches, trash receptacles, and utility boxes.
- ➔ Art can provide information, such as including maps and signage, or be educational in regards to the history and culture of San Francisco's neighborhoods and citizens. All installations do not need an educational mission, however—art can be playful.
- ➔ Public art should be accessible to persons with disabilities and must not be placed in a way that compromises the clear path of travel. Art pieces may require detectable warning strips around the base of the art piece.

Public art should be considered during the planning and design phase of development to more closely integrate art with other streetscape elements.

- ▶ Public art can be functional or include functional elements, such as an attractive bicycle rack or an element that includes seating

#### Sidewalk restrooms

##### *Location of sidewalk restrooms*

Sidewalk restrooms should be located according to the following guidelines:

- ➔ Sidewalk restrooms should be located in the furnishings zone, a minimum of 2 feet from the outside edge of the curb.
- ➔ Sidewalk restrooms should be placed a minimum of 40 inches from existing sidewalk elements such as street trees, benches, and lighting poles.
- ➔ Sidewalk restrooms are not permitted on sidewalk less than 14 feet wide, or on any sidewalk on which their placement would cause pedestrian clear width to be less than the minimum width by street type discussed in Section 4.2. Wider space may be desired in locations with significant pedestrian activity.
- ➔ Wherever possible, sidewalk toilets should be placed at red curb zones that are not bus stops.
- ➔ Sidewalk restrooms should be placed such that they do not block scenic views.





- Sidewalk restrooms should not be located on a sidewalk fronting a restaurant, café, or any other eating establishment. Wherever possible, units should be placed out of the line of vision of any eating establishment. They are not recommended within 50 feet of an existing restaurant or an existing permitted sidewalk café or food market.
- The placement of the sidewalk restroom should not visually or physically obstruct the functioning of an existing, permitted flowerstand or sidewalk vendor.
- Sidewalk restrooms should not be located in front of a building entry and the entry to the restroom should be oriented away from the closest building entry when possible.

Sidewalk restrooms must conform to the guidelines outlined in Department of Public Works Order No. 163,369.

### Streetscape signage

The purpose of streetscape signage, including gateway markers and directional signage, is to provide an overall image of a neighborhood or district, mark edges or entry points, and give information about directions, destinations, or the neighborhood in general.

Streetscape signage plans should be developed on a neighborhood basis, specific to the needs of that district. They are most appropriate to downtown, commercial, or tourist-oriented locations, or around large institutions. Less traveled areas may still include some basic informational signs or neighborhood markers.

Streetscape signage includes a hierarchy of types, from most prominent and central, to least prominent and more common. A hierarchy of streetscape signage includes:

- gateway markers (neighborhood or district entry elements);
- neighborhood orientation signs;
- interpretive signs;

- directional/wayfinding signs; and
- standard street and transit signs.

All types of streetscape signage should follow the general guidelines stated in previous sections of this plan (e.g. location in the furnishings zone, retain sufficient clear path of travel, etc.). In addition, they should follow the guidelines listed here.

#### *All streetscape signage should:*

- be placed at strategic locations with a goal of minimizing the overall number of signs and signage systems necessary; overuse dilutes their effectiveness and clutters the streetscape;
- catch the attention of passers-by but complement the overall streetscape design;
- align with existing site furnishings or be otherwise located out of the path of travel;
- include braille and be multi-lingual as necessary and appropriate to the specific location;
- use a consistent graphic design template; signs that highlight local district or neighborhood character should be encouraged and should be of a similar look and feel throughout that district to enhance the area's sense of place; and
- incorporate neighborhood-specific or artistic elements; flexibility should be granted to artisans and craftspeople to create unique signage.

#### *Gateways*

Gateways are markers or monuments located at the entrance to a district or neighborhood to announce the entry to a particular area, or a transition from one area to the next. Gateways may be a literal gateway, markers on either side of a street, a singular large sculptural or iconic element, or even a unique landscape feature or plaza. They are generally more artistic or sculptural, and less literal or functional than other types of signage. Gateway markers should:



▲ Sidewalk restrooms can be an important amenity for pedestrians, but they should be carefully placed to ensure adequate pedestrian circulation and that they not negatively impact adjacent land uses or views



▲ Wayfinding signage should be in locations with high pedestrian traffic and should be attractive, fitting in with the style of other street amenities, and easily usable to both residents and visitors



▲ Gateway elements can define the entrance to and identity of a neighborhood or retail district

- be located at defined entry points to a district or a neighborhood, or transitions from one neighborhood or district to another. They may also be appropriate at areas where a freeway becomes a surface road, or where there are other significant changes to the roadway, land use, or building form (for example, where a major roadway becomes a quiet residential street);
- be large enough to attract attention and identify the neighborhood entrance;
- incorporate unique artistic, sculptural, or culturally-expressive elements appropriate to the particular neighborhood context; and
- be placed on corner and mid-block curb extensions whenever possible.

#### **Neighborhood Orientation Signs**

Neighborhood orientation signs provide a central element to provide district or neighborhood information, including the area's name, neighborhood map, list of destinations (such as primary cultural institutions, historical buildings, and sites of significance), with a distinctive, coordinated design. Neighborhood orientation signs should:

- be located at key points in the neighborhood, such as at a major transit stop, or a central public space;
- include directories/maps to guide people to various neighborhood resources;



Gateway and neighborhood orientation sign

- highlight public and private destination points, including shopping, cultural and recreational facilities, parking, restrooms, and other public-serving facilities; and
- when appropriate and feasible, use new technologies such as interactive and virtual displays with event or other real-time information; however, such design features should be respectful of the neighborhood context and minimize visual intrusion.

#### **Directional Signs**

On most streets, the typical street sign is all that is needed to orient pedestrians to major destinations. However, on streets and public spaces with heavy pedestrian volumes, additional directional signage is often helpful. This is especially true on streets that handle greater numbers of visitors (such as downtown, ceremonial, or commercial streets), on major transit routes, or in tourist-oriented areas.

Directional signs are typically much simpler than a neighborhood orientation sign, featuring only place names and wayfinding information. They should have a distinct and coordinated design in keeping with the character of the surrounding neighborhood or district. Well-designed directional signs can help create a distinct identity to a neighborhood. In general, directional signs should:

- include destination icons, place names, and directional markers (e.g. arrows) for local destinations on blades or integral to the body of the sign. A map clearly showing current location and the best routes to nearby destinations should also be considered



#### **Historic/Adventure Trail Markings**

Historic and adventure trails highlight unique city spaces, such as historic, civic, and cultural destinations, parks and open space, and unique streets, trails, stairs, and paseos. They can be integrated into sidewalk pavement, the sides of buildings, poles, or public art or other special furnishings to add unique detail and an educational dimension to the streetscape. Trails can be located on any street, and will often cross many street types, plazas, and open spaces as they meander through the city. Trail signage should be complemented by maps, brochures, and other information that can be taken away by people who use the trail. Sidewalk markings are permitted through DPW, and applicants are responsible for their maintenance.

- share existing poles where possible consistent with the signage design, or be designed as an integral streetscape element. Historic streetlight poles, however, should not be used;
- be located in the furnishings zone and as near to intersection corners as is practicable (but outside of the corner zone);
- be easy to spot from far away, but designed to be read from near by a pedestrian with a high level of detailing and craftsmanship; and
- use external illumination that focuses light on the signs themselves, not on pedestrians. Internally illuminated signs should be avoided as they are typically designed to attract drivers and are too intense for pedestrians. Directional signs should use reflective coating to minimize glare.

#### ***Interpretive Signs***

Interpretive signs give historical, cultural, natural or architectural information about their particular locale. They may be part of a historic trail, identify a particular site where an important event occurred, or describe other aspects of a neighborhood's past or present. Interpretive signs should:

- include graphics and photos, with a bold, strong heading and clear, succinct text;
- use a unique, neighborhood-specific design that incorporates creative or artistic elements into the overall design; and
- be coordinated with a centralized directory and map when appropriate.

#### ***Standard Street and Transit Signs***

Standard street and transit signs give basic directional information about street names or transit lines. They are typically located on all street corners and transit stops. They should be built to citywide standards for street or MUNI signs.

#### **Temporary private uses in the public realm**

In addition to permanent public fixtures, site furnishings also include moveable or temporary elements or uses, typically placed in the sidewalk area by private businesses or residents. Temporary private uses in the public realm are generally encouraged as they create a lively and colorful street environment, animate public space, and provide 'eyes on the street'. However, they should be designed and located to ensure safety, accessibility, and appropriate maintenance. Temporary elements include:

- outdoor café and restaurant seating;
- merchandise displays;
- street food vendors (Pushcarts and peddlers); and
- street artists.

These uses are permitted through various City agencies, including DPW, DPH, Police, Fire, Planning, and others. Permit requirements and responsible agencies are summarized below.

#### ***Outdoor café and restaurant seating***

Outdoor café and restaurant seating (tables and chairs) is encouraged to activate the sidewalk environment and encourage economic development. Outdoor café and restaurant seating require a Street Use Permit from DPW.

Tables and chairs should abide by the following guidelines:

- Tables and chairs can be placed only on the sidewalk in front of the applicant's place of business.
- The sidewalk in front of the business must retain a minimum pedestrian clear width per Section 4.2. This clearance must be free of all obstacles.
- Placement of tables and chairs on the sidewalk must not in any way interfere with curb ramps, access to the building, driveways or access to any fire escape.



▲ Outdoor seating enlivens the pedestrian realm

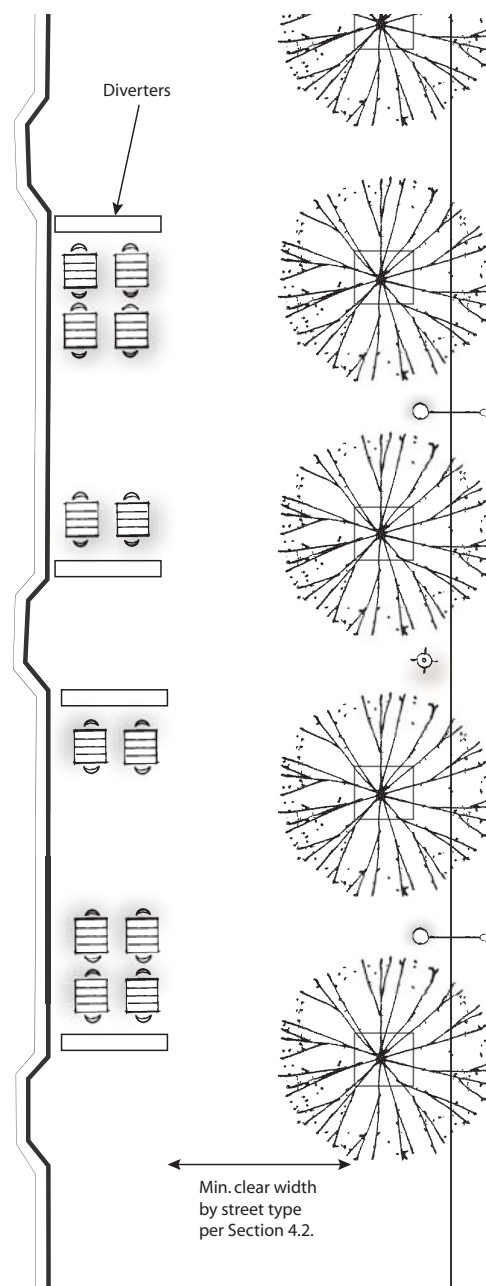

▲ Outdoor cafe and restaurant seating

- Tables and chairs are allowed in the frontage zone where sufficient sidewalk width is available.
- Tables and chairs may also be permitted in the furnishings zone, on a case-by-case basis as determined by DPW. DPW will consider safety (risk from passing vehicles) and accessibility (people crossing the pedestrian throughway) in their review. Tables and chairs in the furnishings zone are more appropriate on calmer streets or where a buffering element (such as planters or parked vehicles) between the sidewalk and travel lanes exists. Tables and chairs in the furnishings zone must be located so as to maintain access to parked vehicles, and may not be located on sidewalks adjacent to accessible parking (blue) or passenger loading (white) zones.
- Placement of tables and chairs on the sidewalk must include diverters at each end to guide pedestrians away from the occupied area of the sidewalk. Diverters must:
  - be flush with building at approximately 90 degrees;
  - be sturdy, stable, and have sufficient weight so that they cannot tip over or be blown away by the wind;
  - be at least 30-inches high and must be solid within 24-inches of the ground;
  - have contrasting colors so that they are distinctly visible to the visually impaired; and
  - be removable at the end of business hours.

In some locations, temporary café and restaurant seating may be located in the parking lane, where there is a program for flexible use of the parking lane. See Section 5.6.

### **Merchandise displays**

Sidewalk merchandise displays can enliven the pedestrian realm and enhance the viability of retail establishments in commercial districts. Merchandise displays require a Street Use Permit from DPW.

Merchandise Displays should abide by the following guidelines:

- Merchandise Displays may be placed only on the sidewalk in front of the applicant's place of business
- The sidewalk in front of the business must retain a minimum pedestrian clear width per Section 4.2. This clearance must be free of all obstacles.
- Placement of merchandise displays on the sidewalk must not in any way interfere with curb ramps, access to the building, driveways or access to any fire escape.
- The top of the display, including stand and merchandise, must be at least 2 ½ feet above the sidewalk. The top of the display may not be more than 3 feet and 10 inches above the sidewalk nor more than 2 feet or 25% of the width of the sidewalk in front of the building (whichever is less).
- Display of fruits and vegetables must be protected by an awning, which must extend a minimum of 6 inches beyond the full length and width of display racks.
- The finish materials used for display merchandise must be smooth, non-absorbent and cleanable.



**Street vendors (Pushcarts and Peddlers)**

Street vendors (pushcarts and peddlers) – selling food or other items – can enliven a district and provide jobs and services. Pushcarts and peddlers are permitted through the Police Department. Food vendors also require permits from the Department of Public Health. Other City departments may also review permit applications. Permitted Pushcart and peddlers must abide by the following:

- Permits are for one location only.
- Pushcart and peddler permits may not be issued for a location within 2 blocks or 600 feet, whichever is greater, of an established business which sells the same type of food or other merchandise as the applicant, or of any location currently being operated by a peddler or pushcart peddler selling the same type of food or other merchandise.

→ Pushcart and peddler locations must:

- leave a minimum of 10 feet of unobstructed space for pedestrian passage on any sidewalk;
- not occupy a space extending more than 4 ½ feet from the curb line of any sidewalk, nor wider than 4 feet, nor extending more than 5 feet above the sidewalk;
- not be within 18 inches of the curb line of any sidewalk;
- not be closer than 7 ½ feet from the sprinkler inlets, wet and dry standpipe inlets, measured from the outer edge of the standpipe bank from the building line to the sidewalk edge;
- not be within 12 feet of the outer edge of any entrance way to any building or facility used by the public including, but not limited to doors, driveways, and emergency exits measured in each direction parallel to the building line at a 90 degree angle to the curb;
- not be on any sidewalk adjacent to a white, yellow, blue, or red zone, or a bus zone;

- not be within 5 feet of any crosswalk or fire hydrant;
- leave unobstructed fire escapes, underneath and perpendicular from the building to the street, 5 feet from both ends of the fire escape; and
- not be within 5 feet of inflammable liquid vents and fill pipes when tanks are not being filled nor within 25 feet while tanks are being filled.

**Street artists**

The street artists program licenses artists to sell their work on city streets. Street artists are permitted through the Arts Commission. Artists must present their work to a screening committee, obtain a certificate licensing them to sell their work, and participate in a lottery to see which spaces they will occupy. The Board of Supervisors sets appropriate locations for street artists.

Per pushcart and peddler requirements, street artist booths must adhere to the following dimensions:

- booths may be no more than 3 feet wide, 4 feet long, and 5 feet high;
- booths may not be within 18 inches of the curb;
- booths may not be within 5 feet of a fire hydrant or crosswalk;
- booths may not be within 12 feet of the outer edge of an entrance or doorway;
- booths must maintain at least 10 feet clear pedestrian pathway.

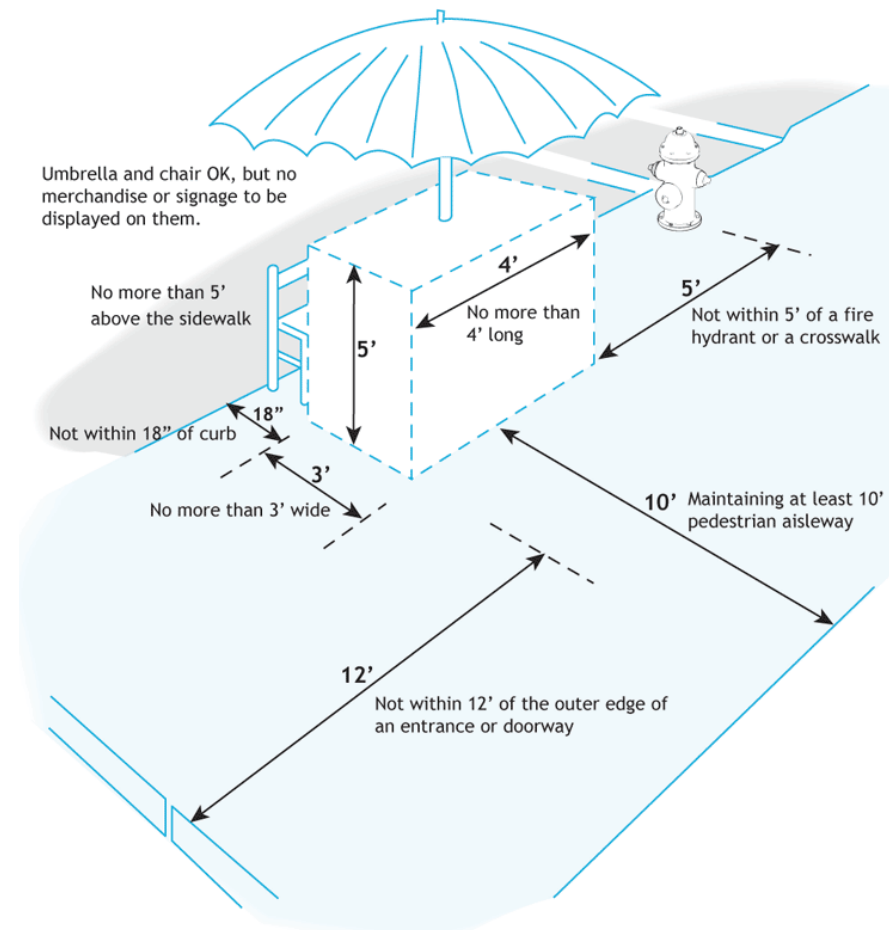

▶ Basic dimensional requirements for street artist displays

Source: San Francisco Arts Commission

## Traffic and parking signs

Traffic and parking signs convey essential information to drivers, cyclists, and pedestrians. However, if misplaced or overused, they may become too numerous, create a cluttered streetscape environment, and lose their efficacy as signage.

### *Location and placement*

Traffic and parking signs should be located in the edge zone. They should be placed at either end of parking stalls, and aligned along the block.

Traffic and parking signs should not be placed so that they will be obstructed by other streetscape elements. However, other desirable elements such as street trees or light poles should not be moved to accommodate new signage;

rather, signs should be placed around existing features and around the ideal locations of plantings, lighting, and site furnishings.

Signs may be placed within planters as long as they are concrete-set.

### *Consolidation*

Traffic and parking signs should be consolidated onto single poles wherever possible. New signs should use existing poles wherever possible. Stand alone signs should only be located where no other sign exists within 100 feet.

When redesigning streets, designers should look for opportunities to consolidate existing signage onto shared poles.

## Trash receptacles

### *Location of trash receptacles*

Trash receptacles should be located according to the following guidelines:

- Trash receptacles should be located near as near to corners as is practicable but out of the corner clear zone.
- They should be located near high activity generators such as major civic and commercial and transit destinations.
- There should be a maximum of one trash receptacle every 200 feet along commercial streets. Additional trash receptacles should be provided only if a private sponsor provides continued maintenance.
- A maximum of four trash receptacles should be provided at an intersection (one per corner).

### *Design of trash receptacles*

When selecting trash receptacles, they should be considered as a design element, and design should reflect aesthetic as well as functional concerns.

Trash receptacles should be selected from the same or a similar design “family” as other site furnishings (such as benches, bollards, bike racks, etc.) and should be finished or painted to complement other site furnishings.

Trash receptacle construction should use durable, high-quality materials, such as galvanized or stainless steel. Materials should be painted to reflect colors similar to nearby elements. Material and paint selection should be graffiti resistant.

Trash receptacles should include recycling containers and should be able to open from the side to allow easy access for removal of garbage bags.



◀ Trash receptacles should be conveniently located near high pedestrian traffic areas



# Utilities and Driveways

## 6.6

### Utilities

Utilities in the streetscape consist of utility poles and overhead wires, surface-mounted utility boxes, utility mains, laterals, vaults, and valves. They include sewer, water, gas, and telecommunications, as well as traffic signals, street lights (discussed in Section 6.3), and Muni poles and wires.

Utility installation can occur as a new installation (on new streets or as a part of new development), retrofit or upgrade to an existing system (such as undergrounding of overhead wires or sewer upgrades), or emergency repair. Utility installations, upgrades, consolidation, rearrangements, or realignments may also occur as part of other street or sidewalk improvement projects.

Utilities are a necessary and ubiquitous element of streetscape environments. Though essential, utilities often constrain the ability to locate other streetscape elements and can create a cluttered visual environment. Conversely, other streetscape elements may conflict with the ability to access and maintain utilities.

Well-organized utility design and placement can lead to:

- minimization of streetscape clutter to achieve a cohesive streetscape design;
- maximization of space for plantings;





- improved efficiency of utilities and integrated alignment with stormwater facilities, street furnishings, and street lighting;
- reduced cutting and trenching;
- possible reduction of long-term street and sidewalk closures;
- reduced long-term maintenance conflicts and potential costs; and
- improved pedestrian safety, quality of life, and right-of-way aesthetics.

## GUIDELINES

### Locating Utilities

Utilities should be placed to minimize disruption to pedestrian through travel and potential planting and site furnishing locations while maintaining necessary access for maintenance and emergencies, per the following guidelines:

**Roadway/Parking Lane:** Large utility vaults such as network or transformer vaults, and conduits running the length of a city block, should be located in the roadway or parking lane where access requirements allow. Vaults in the parking lanes should be striped as a temporary parking area, in a no parking zone, or in front of driveways.

Utility vaults located in the street must be rated to City loading standards based on expected use and vehicle type.

**Edge zone:** Small utility vaults such as residential water vaults, residential water meters, gas valves, gas vaults, or street lighting should be located in the edge zone wherever possible to minimize conflicts with existing or potential tree locations. Vaults should be aligned or clustered wherever possible.

Generally, utility boxes are sited in the direction of the pipe.

- Utility boxes that are parallel with the curb should be located in the edge zone or throughway zone where possible, or between existing or potential street tree or sidewalk landscape locations.
- Utility boxes that are perpendicular to the curb should be located between existing or potential street tree or sidewalk landscape locations, such as where pass-throughs to parked cars are placed.

**Furnishings zone:** Utility vaults and boxes should be located outside of the furnishings zone wherever possible to maximize the number and size of tree wells and the ability to connect tree wells into continuous strips.

Utility laterals should run adjacent to, not directly under, potential site furnishing and tree planting locations wherever possible (such as through driveways or between tree



▲ Utilities are often scattered in the sidewalk without consideration for the overall streetscape environment

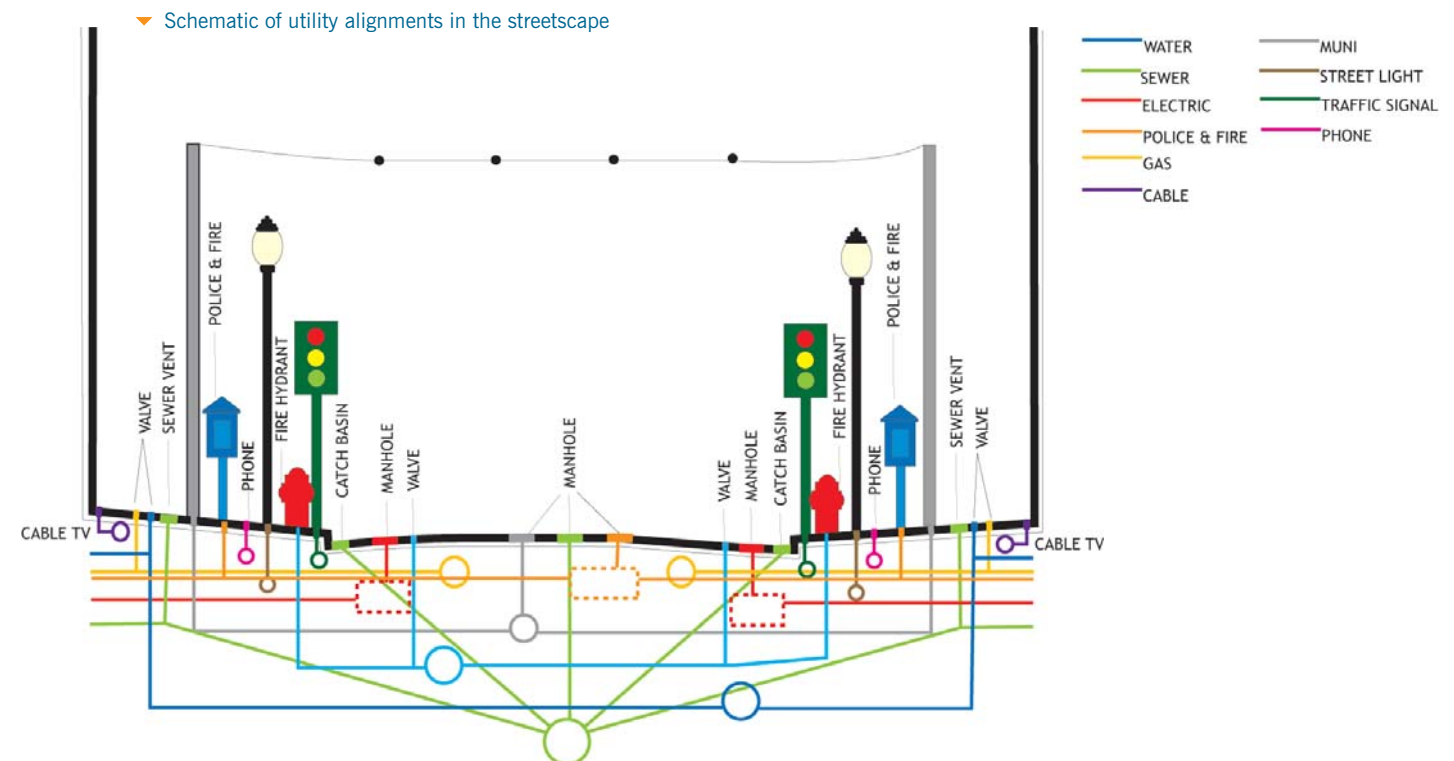



▲ Many streets have few or no trees for entire block lengths because subsurface utilities limit the ability to plant



▲ Utility vaults may be located within planting areas as long as access is maintained

Figure 6.11. Appropriate Utilities by Sidewalk Zone

	SMALL UTILITY STRUCTURES								LARGE UTILITY STRUCTURES					
	Sewer Vents	Sewer Clean-outs	Water Valves	Water Vaults	Water Meters	Gas Valves	Gas Vaults	Street Lighting (Vaults)	Utility Laterals	Irrigation Lines	Utility Conduits	Large Electrical Utility Vaults	Large Telephone Utility Vaults	Combined Dry Utility Vaults
Edge Zone	●	●	●	●	●	●	●	●	●	○	○	×	×	○
Furnishings Zone	○	○	○	×	×	○	×	○	○	○	○	×	×	×
Throughway Zone	○	○	○	○	○	○	○	○	○	●	●	●	●	○
Frontage Zone	○	○	○	○	○	○	○	○	○	○	○	×	×	○
Corner Zone	×	×	×	×	×	×	×	○	×	×	×	×	×	×
Curb Extensions and Parking Zone	×	×	×	×	×	×	×	○	×	○	×	×	×	×
Streets	×	×	×	×	×	×	×	×	×	×	●	●	●	●

● Preferred ○ Acceptable × Not Recommended

basins). Subsurface utility conduits and irrigation lines should avoid running under the length of the planting area to minimize root interference. Water meters should also be located outside this zone where possible to avoid interference from tree roots. Street trees should maintain adequate clearance from water meters to avoid damage to the meter from tree roots.

If several shallow utility laterals are unavoidable, planting areas may still be created and should utilize ground cover or low shrub plantings without the incorporation of deep rooted trees, per Section 6.1.

Surface-mounted utilities may be located in the furnishings zone, per DPW Director’s Order #175,566. Surface-mounted utilities such as hydrants and air valve enclosures must be set on a concrete base if located within planted areas

**Throughway Zone:** Utility vaults and conduits running the length of the city block may be located in the throughway zone. Vaults in the throughway zone should meet DPW Director’s Order #176,112 guidelines for slip-resistant covers.

Large utility vaults should be placed at least 3 feet from building and 4 feet from curb where sidewalk widths allow.

Surface-mounted utilities should not be located in the throughway zone.

**Frontage Zone:** Utility vaults and valves may be placed in the frontage zone. Placement of utility structures in this zone is preferred only when incorporating utility vaults into the edge zone is not feasible.

Utility vaults in the frontage zone should not be located directly in front of building entrances.

**Extension Zone:** Utility vaults and valves should be minimized in curb extensions where plantings or site furnishings are desired.

Surface-mounted utilities may be located in curb extensions outside of crossings and curb ramp areas to create greater pedestrian through width.

Utility mains located in the parking lane and laterals accessing properties may pass under curb extensions.

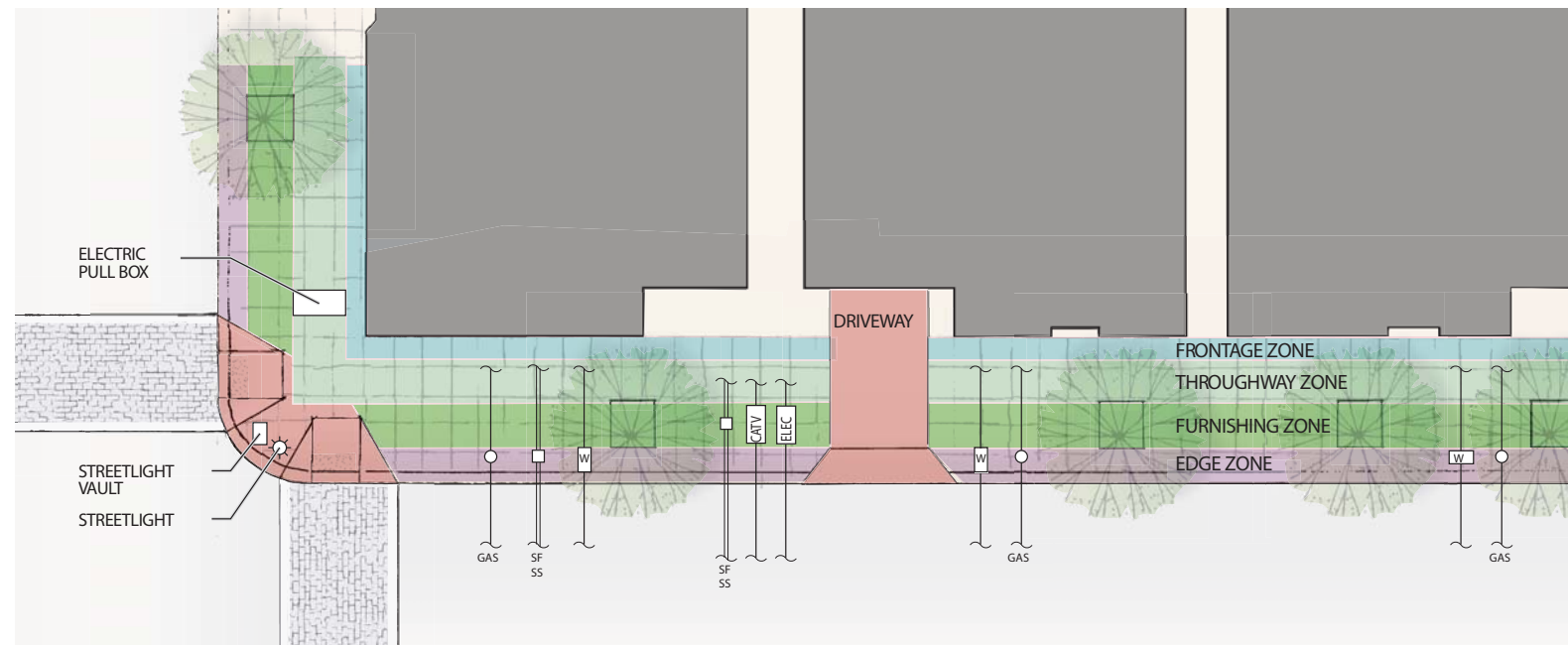

Recommended Utility Locations for Residential (Neighborhood and Throughway) Street Types

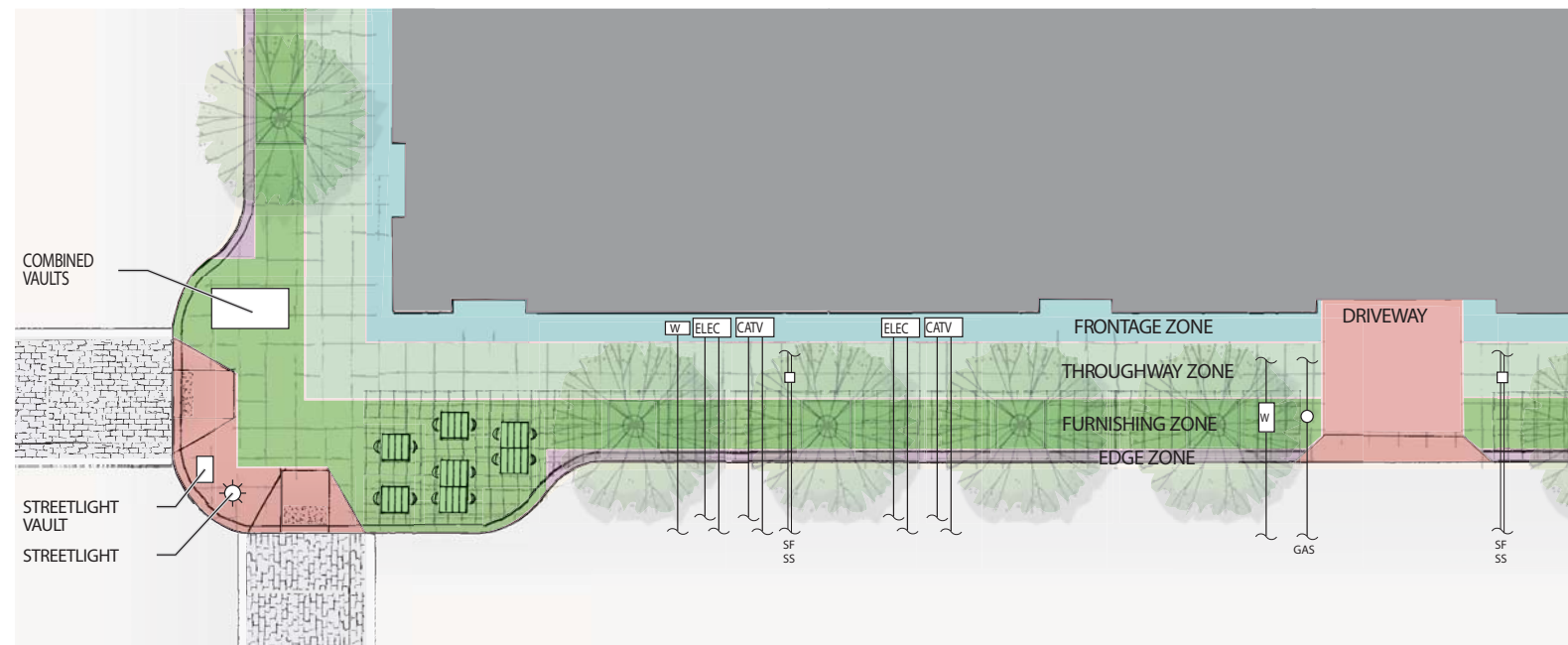

Recommended Utility Locations for All Other Street Types (Including Downtown Residential)

**NOTE:**  
Utility locations are for representation only and should be placed per City and County of San Francisco Standards and PG&E Greenbook Standards.

### → Utilities Permitting in San Francisco

Public utilities (e.g. PG+E, Comcast, ATT, etc.) all have franchise agreements with the state and do not require a city encroachment permit; however, they require an excavation permit and are subject to the Excavation Code (DPW Director's Order #176,707), and Surface-Mounted Utility guidelines (DPW Director's Order #175,566).

Privately installed utilities do not fall under the state franchise agreements and are required to get a major encroachment permit for significant streetscape or capital improvement infrastructure projects.

City utilities (water, sewer, street lighting, and traffic signals) need an excavation permit but not an encroachment permit.

The Fire Department does not require a permit from Bureau of Streets and Mapping for water infrastructure.

With curb extensions or sidewalk widenings, utilities such as water mains and meters, or sewer vents may remain in place as it may be cost-prohibitive to move them per the SFPUC “Bulb-out and Sidewalk Widening Guidelines for Water and Sewer” and SFPUC review.

**Driveways:** Utility laterals and vaults should be located so as to avoid potential street tree and sidewalk landscaping locations. Particularly in instances where there are frequent driveways, alternate locations for utilities should be sought so as not to take up available street tree planting locations. Utility boxes may be located in driveways if the sponsor provides a vehicle-rated box; however, this is not a preferred solution due to access difficulties.

**Pedestrian Crossings and Curb Ramps:** New utility structures should not be placed within street crossing and curb ramp areas wherever possible.

If existing vaults conflict with ramp areas, vaults should be moved or modified to meet accessibility requirements as feasible as part of utility upgrades.

Catch basins and surface flow lines associated with storm drainage systems should be located away from the crosswalk or between curb ramps. On new streets, catch basins should be located upstream of curb ramps.

### Consolidation

Utilities should be consolidated for efficiencies and to minimize disruption to the streetscape, per the following guidelines:

- Dry utility lines and conduits (telephone, CATV, electric, and gas, etc) should be initially aligned, rearranged or vertically stacked to minimize utility zones. Designers should refer to the Typical Distribution Trench schematic (from PG&E) for placement of joint utilities within a public utility easement.

- Wherever possible, utility conduits, valves, and vaults (e.g. PG&E, or street lighting and traffic signals) should be consolidated if multiple lines exist within a single street or sidewalk section.
- Dry Utilities (gas, telephone, CATV, primary and secondary electric, streetlights) should use shared vaults wherever possible. Shared vaults should be installed with predetermined color coded conduits per predetermined city standards with a consideration for future public and private conduits. Private companies would have the option to purchase from the City or Utility any unused networks of existing conduit in-lieu of installing a new a separate conduit route along a constrained street.
- Fiber optic lines can be installed within active sewer trunk lines to minimize trenching.
- Surface-mounted utilities should share boxes wherever possible.
- Street lighting, traffic signal, and MUNI catenary poles should share poles wherever possible, and wherever doing so would not significantly alter the placement of these elements per the guidelines in other sections of this document. When retrofitting existing streets or creating new streets, pursue opportunities to combine these poles.

### Design Guidelines

Street design and new development should consider overall pattern of plantings, lighting, and furnishings when placing new utilities in the street, and locate utility lines so as to minimize disruption to the prevailing streetscape rhythms per the following guidelines:

- Utilities should be located underground wherever possible, as opposed to overhead or surface-mounted.
- New utilities should use durable pipe materials that are resistant to damage by tree roots, such as ductile

iron, polyethylene, or polypropylene pipes. The preferred material for water pipes is ductile iron.

- New utilities should use pipes with minimal joints.
- Utility vault covers should be made of slip resistant materials, per DPW Director’s Order #176,112.
- The City should pursue the use of “trenchless” technologies, such as sealants, pulling cables through tunnels, etc. wherever possible, to avoid excavation and disruption of streetscape elements.
- New infrastructure projects should use resource-efficient utility materials, such as recycled PE conduit instead of PVC conduit, as stock materials deplete. Re-used or recyclable materials should be incorporated wherever possible.

- Tree removal should be avoided and minimized during the routing of large-scale utility undergrounding projects
- Any utility-related roadway or sidewalk work should replace paving material in-kind (e.g. brick for brick) where removed during emergency or construction per DPW Director’s Order #176,707, Section 12.4B. (Pavement made of special materials shall be restored in kind.)
- Where landscaped medians are realigned or created during a major street improvement project, existing combined sewer manholes should be raised (6 inch above finish grade) to form an overflow drain inlet within a depressed planted median. This would create a stormwater facility using the existing infrastructure. Catch basin laterals may then be removed as allowable.

### Access and Maintenance

Major utilities (sewers, fire hydrants, gas and water meters and mains, manholes and utility vaults, and utility poles) should be installed at least 5 feet from the edge of existing or proposed tree basins.

Minor utilities (laterals, vaults, valves, etc) should be installed at least 3 feet from the edge of new or existing tree basins.

Utility Poles should be accessible by a 3 foot path.

Refer to City and County of San Francisco Standard Plans and Excavation Code (DPW Director’s Order #176,707) for utility installation standards.

### ➔ Screening of Surface-Mounted Utilities

Surface-mounted utilities are often bulky and unattractive elements in the streetscape. Where possible, they should be located outside of the right-of-way and screened within private parcels. However, in many cases, they will be located in the public right-of-way. To that end, they should minimize their negative visual impact.

Surface-mounted utilities (SMUs) require an excavation permit from the Department of Public Works, and must comply with DPW Director’s Order #175,566. In addition, when located in the public right-of-way, SMUs should be screened per the following:

- SMUs should be painted a neutral color to blend in with background street elements. Alternatively, they may be considered an artistic element in themselves, and boldly painted as part of public art in the streetscape.
- Where sidewalk dimensions allow, SMUs should be screened by elements appropriate to the particular street type.
  - For example, on residential streets, they may be buffered on either side and behind by sidewalk plantings with tall, leafy shrubs. Sidewalk plantings should adhere to the guidelines in Section 6.1, and should fit in with the overall planting palette of the street. Buffer plantings should generally be 6 to 24 inches in width, and should retain access to the front of the cabinet.
  - On commercial or mixed-use streets, SMUs may be screened by low seating walls, artistic screens, or other elements. Plantings might be incorporated through vertical metal lattices with climbing vines to screen the utility boxes.



Surface-mounted utility boxes: unadorned and painted as part of a public art program (from San Diego)





▲ Overhead utility wires detract from the aesthetic experience of the streetscape

### ➔ Utility Undergrounding in San Francisco

Community members often cite utility undergrounding as one of the top priorities for street improvement. When undergrounding occurs, placement of utilities should follow the guidelines in this section to minimize disruption to the overall streetscape design. The bigger challenge with utility undergrounding is the ability to pay for an on-going program of undergrounding.

To address this challenge, the Board of Supervisors created the Utility Undergrounding Task Force (UUTF) in 2004, consisting of 15 appointed voting members, and staff from City agencies and utility providers, to advise the Board on the future of utility undergrounding in San Francisco. The UUTF presented a final report to the Board of Supervisors on January 26, 2007.

To paraphrase the UUTF final report:

#### BACKGROUND

In 1996, the Board of Supervisors legislated the undergrounding of forty-two miles of overhead utility wires (subsequently expanded to 45.8 miles). After completing those 45.8 miles, San Francisco will have undergrounded 520 miles of overhead wires out of 990 miles, leaving 470 miles remaining.

The main obstacle in continuing to underground the City's utilities is a lack of funding. Utility undergrounding in California is primarily funded by two sources, known as Rule 20A and Rule 20B, both overseen by the California Public Utilities Commission (CPUC). Rule 20A funds are paid 90% by utility providers (such as PG+E), and 10% by the City and County. San Francisco has received an average of \$6 million in Rule 20A funds, enough to pay for about 1.5 miles of undergrounding per year. However, as of 2007, San Francisco had borrowed twelve years into the future for Rule 20A funds.

Rule 20B funds are shared by utilities and property owners, typically through special Community Facilities Districts (Mello-Roos Districts); the property owner share may also be borne by the City. San Francisco has not generally used Rule 20B funds; however, the opportunity to use these funds exists.

#### RECOMMENDATIONS

The UUTF recommended the following City actions:

1. Develop a long-term master plan and a properly funded program to underground all utility wires within fifty years.
2. Create a transparent community process that involves residents in the decision-making process.
3. Request the CPUC to approve an electric/natural gas surcharge for San Francisco residents.
4. Seek alternative funding sources for utility undergrounding.
5. Establish a City policy of no new overhead utility wires.
6. Implement a utility undergrounding program that reduces current project timelines by 50% and project costs by 25%.

The City is currently exploring ways to continue to fund undergrounding efforts in San Francisco.

For more information on the report on undergrounding in San Francisco, see:

[http://www.sfgov.org/site/sfdpw\\_page.asp?id=32694](http://www.sfgov.org/site/sfdpw_page.asp?id=32694)

Source: Utility Undergrounding Task Force Report to the San Francisco Board of Supervisors, January 26, 2007

### New Development and Major Redevelopment

Within new development and major redevelopment areas:

- Where appropriate, the City should support the installation of separate stormwater and wastewater collection systems in areas where not already implemented by SFPUC.
- New residential development areas should incorporate alleys for vehicle, utility, and service access so as to enable a more consistent streetscape and minimize above-ground utilities.
- New development should locate new utilities to minimize disruption to streetscape elements per guidelines in this section.

### Abandonment

Currently abandoned dry conduits should be reused or consolidated if duplication of lines are discovered during street improvement projects. Utilities should be contacted for rerouting or consolidation.

Where it is not possible to reuse abandoned mains, conduits, manholes, laterals, valves etc., they should be removed per agency recommendations when possible in order to minimize future conflicts.

Abandoned water and sewer lines may be retrofitted as dry utility conduits where available or if possible to minimize the need for future conduit installations.

### Process

Utilities should be installed during a full-street, half-street, or full or partial sidewalk improvements rather than as a separate utility cut wherever possible.

New development should submit utility plans with initial development proposals so that utilities may be sited to minimize interference with potential locations for streetscape elements.

Utility installation or repair should be conducted from the bottom up; scheduled utility installation or repair should occur prior to planned street reconstruction or major streetscape improvements.

The City should use major utility work as an opportunity to build streets back to desired conditions, per Better Streets Plan guidelines.

### → Best Practice: New York City High Performance Infrastructure Guidelines

New York, New York

The New York City High Performance Infrastructure Guidelines provide a roadmap for incorporating street wide best management practices (BMPs) into New York City's right-of-way infrastructure capital program. They are written for the Department of Design and Construction, but they are just as useful for by planners, designers, engineers, public officials, and all other services involved in constructing, operating, or maintaining the right-of-way.

The guidelines act as the first step toward improving design collaboration while enhancing environmental, social, and economic outcomes for the City's infrastructure investments.

See <http://www.nyc.gov/html/ddc/html/ddcgreen/highperf.html>

## Driveways

Driveways allow necessary access across the sidewalk to residential and commercial garages. Too many driveways are a negative presence in the pedestrian environment, as they present potential conflicts between drivers and pedestrians and increased possibility that pedestrian through travel will be compromised.

In many areas, the high number of driveways and width of driveway curb cuts reduces the available space for planting and other amenities. Improved driveway design can provide added space for planting to improve street aesthetics.

### GUIDELINES

Driveways should be designed to minimize impact on through travel or pedestrian use of the sidewalk.

Driveway curb cuts for individual residential properties should not be wider than 7 feet with 1 1/2 foot wings (10 feet total width). Where truck loading is the dominant activity, they should not be wider than 8 feet with 1 1/2 foot wings (11 feet total).

Driveway curb cuts for two-way traffic should not be wider than 18 feet. An exception should be made on industrial

streets in locations requiring frequent access for large trucks or semi-tractor trailers, where two-way driveway curb cuts may be up to 24 feet in width.

DPW standard plans for driveways should be consulted for engineering standards for driveway construction.

Curb cuts are discouraged in pedestrian-intensive areas. Reducing driveways reduces the number of conflict points between pedestrians and vehicles and can dramatically improve safety.<sup>1</sup>

Wherever possible, commercial, industrial, and large residential properties should consolidate driveways by interconnecting parking lot and loading area entries and by sharing parking among uses.

In areas of San Francisco where alleys provide access to the rear of properties, curb cuts onto streets are strongly discouraged; all parking and service access should be provided via the alley.

On new streets, alleys should be provided, minimizing the need for new driveway cuts on primary streets.

Because driveways handle relatively low volumes of traffic, alternative surfacing materials including unit pavers and other permeable materials may be installed in driveways where frequent heavy trucks are not expected to cross over. The clear throughway zone of the sidewalk should be a continuous material.

Driveways may be bounded by permeable paving, curb extensions or landscaping areas that extend from the sidewalk into the parking lane, eliminating the need for driveway aprons.

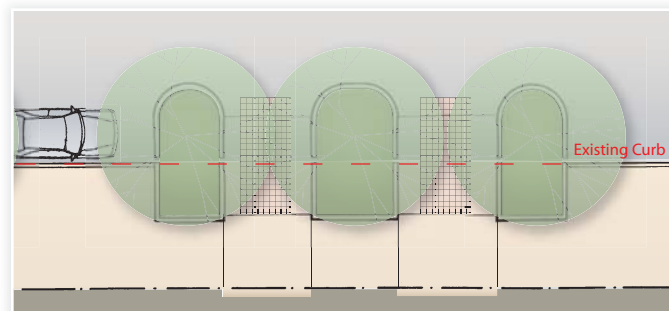

- ▲ Parking-lane planters can be located between driveways where space is too narrow to allow a vehicle to park. Where planters extend into the sidewalk furnishings zone, they can be designed to occupy the space of driveway wings, narrowing the driveway and widening the planting area.

<sup>1</sup> Source: <http://www.ctre.iastate.edu/research/access/toolkit/3.pdf>. See also pages 11-13 of the following document: [www.ctre.iastate.edu/PUBS/tsinfo/1-6.doc](http://www.ctre.iastate.edu/PUBS/tsinfo/1-6.doc)